

ROHS COMPLIANT LEAD&HALOGEN FREE

REV.	DESCRIPTION	DATE	DRAWN
A	Release rev.A for production	Dec/02/2023	Frank Zhou

1 芯数/NO. OF CONTACTS

芯数 Pin Number	02Pins	03Pins	04Pins	05Pins	06Pins	07Pins	08Pins	12Pins	14Pins	16Pins	19Pins	24Pins
适合线缆/Conductor size	0.75mm <sup>2</sup>	0.75mm <sup>2</sup>	0.75mm <sup>2</sup>	0.75mm <sup>2</sup>	0.75mm <sup>2</sup>	0.75mm <sup>2</sup>	0.75mm <sup>2</sup>	0.25mm <sup>2</sup>	0.25mm <sup>2</sup>	0.25mm <sup>2</sup>	0.25mm <sup>2</sup>	0.25mm <sup>2</sup>
导体直径/Pin size	1.5mm	1.5mm	1.5mm	1.5mm	1.5mm	1.5mm	1.5mm	1.0mm	1.0mm	1.0mm	1.0mm	0.5mm
额定电流/Rated current	7A	7A	7A	7A	5A	5A	5A	3A	3A	3A	1A	1A
额定电压/Rated voltage	250V	250V	250V	250V	125V	125V	125V	60V	60V	60V	60V	60V

2 料号说明/PART NUMBER (M16 Series Assembly/Panel-Mount Type)

面板开孔/RECOMMENDED PANEL CUT-OUT

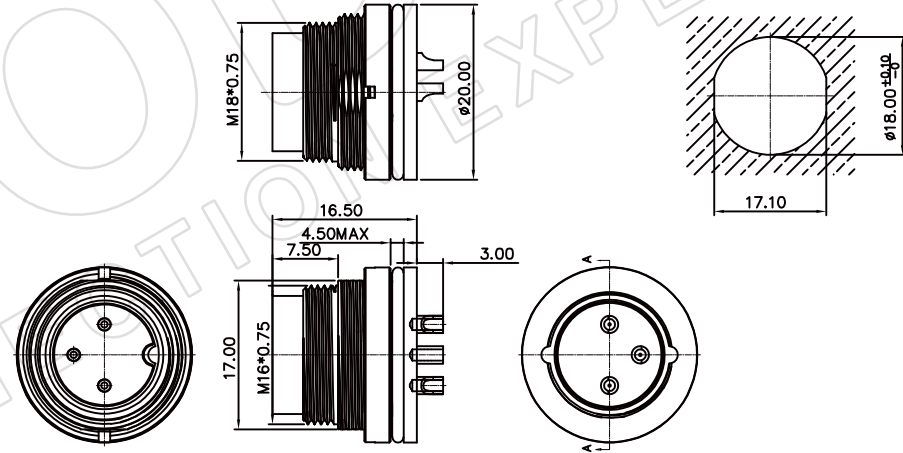
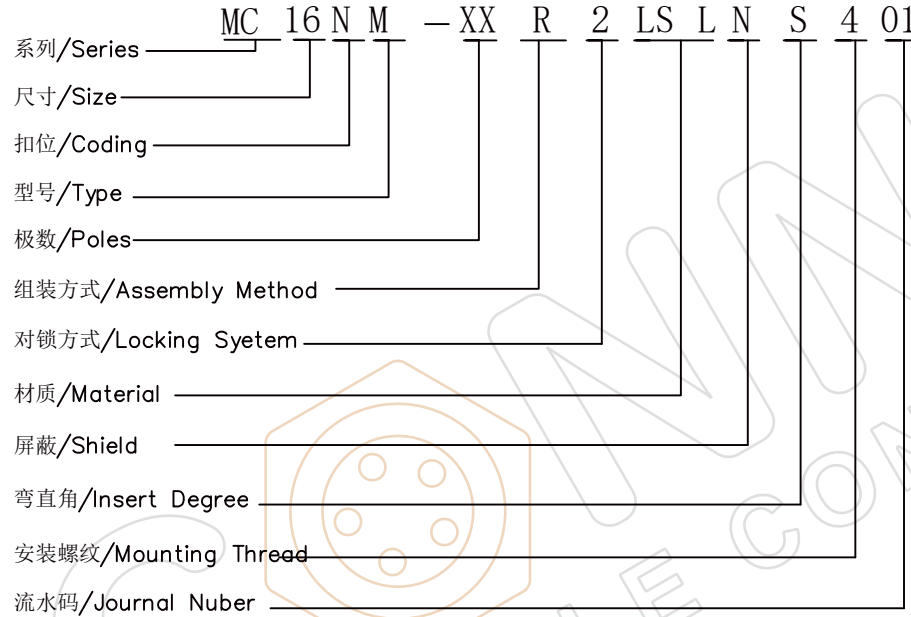

5	NUT	COPPER ALLOY	NICKEL PLATED
4	O-RING	RUBBER	COLOR: BLACK
3	SHELL	COPPER ALLOY	NICKEL PLATED
2	PIN	COPPER ALLOY	GOLD PLATED
1	Housing	HIGH TEMP. THERMOPLASTIC	UL 94V-0, COLOR: BLACK
No	Parts Name	Material	Finish/Color

3 技术参数/Technical information

1. 接触电流CURRENT RATING: 12A MAX.
2. 接触电压CURRENT VOLTAGE: 63V MAX.
3. 绝缘电阻.INSULATION RESISTANCE: 100M OHMS MIN.
4. 接触电阻CONTACT RESISTANCE: 30m OHMS MAX.
5. 操作温度OPERATING TEMPERATURE: -40°C TO +85°C.
6. 盐雾/SALT SPRAY: 24 HOURS.
7. 防水等级CLASS OF PROTECTION: IP40



**CONNODER**  
RELIABLE CONNECTION EXPERTS

Website: www.connoder.com  
E-Mail: sale@connoder.com  
CONNODER ELECTRONIC TECHNOLOGY CO LTD

GENERAL TOLERANCES (UNLESS SPECIFIED)	DRAWN BY: Frank Zhou	TITLE: M16 Series Male Solder Rear Fastened
X.X ± 0.35	X.' ± 3'	PART NO.: MC16NM-XXR2LSLNS401 DWG NO.: MC16NM-XXR2LSLNS401-P CUSTOMER:
X.XX ± 0.25	X.X' ± 2'	
X.XXX ± 0.15	X.XX' ± 1'	
THIRD ANGLE PROJECTION	APPROVED BY:	SCALE: NONE
DIMENSION STYLE: MM ONLY	DESIGN UNITS: METRIC	SHEET: 1 of 1

THIS DRAWING CONTAINS INFORMATION THAT IS PROPRIETARY TO SHUNKONN AND SHOULD NOT BE USED WITHOUT WRITTEN PERMISSION

REV.	DESCRIPTION	DATE	DRAWN
A	Release rev.A for production	Dec/02/2023	Frank Zhou

# MXX系列连接器成品料号编码原则

## MXX Series Connector Product Part Number Coding Principle

MC16 N M - XX R 2 LS L N S 4 01

1 2 3 4 5 6 7 8 9 10 11 12 13

1、产品型号 Product Model:

MB=M系列线束 M Series Harness, MC=M系列连接器 M Series Connectors

2、尺寸 SIZE:

05=M5, 08=M8, 09=M9, 10=M10,12=M12, 14=M14,16=M16,23=M23,78=7/8 Series

3、编码 Coding:

A=A coding B=B coding C=C coding D=D coding  
K=K coding L=L coding S=S coding T=T coding  
X=X coding Y1=Y coding type1  
Y2=Y coding type2 Y3=Y coding type3  
Y4=Y coding type4  
N=表示正常普通型 NORMOL

4、公母 Male Female:

M=male, F=female

5、孔数 Poles:

01=1PIN, 02=2PIN, 03=3PIN.... 依次类推 In A Similar Fashion

6、组装方式 Assembly Method:

F=前装 Front Mount R=后装 Rear Mount  
L=凸缘 Flange U=Other Forms 其它形式

13、流水码 Journal Number :

01(同一端子长度, 在同一形态、同一PIN数下自1-9流水号)  
01 (The Same Terminal Length, In The Same Form, The Same Pin Number From 1-9 Running Number)

12、安装螺纹 Mounting Thread

1=M12\*1.0, 2=M15\*1.0, 3=M16\*1.5, 4=M18\*0.75, 5=M20\*1.5, 6=PG7, 7=PG9, 8=PG11

11、90 Degrees, 180 Degrees And SMD 90度, 180度和SMD

S=Straight 直的 R= Right angel 拐角的 M=SMD

10、是否带屏蔽 Shielded Or Not

N=表示不带 Means Without, L=长屏蔽 Long Shield, S=短屏蔽 Short Shield

9、外壳类型 Housing Type

S=冲压 Stamping, L=车件 Lathe, A=铝压铸 Aluminum Die Casting  
Z= 锌合金压铸 Zinc Alloy Die Casting, P=注塑 Injection Moulding

8、公母针类型 Male and Female Pin Type

LS=车件焊接型 Solder, SS= 冲压焊接型 Stamping Welding, LC=车件压接型 Crimp  
SC=冲压压接型 Stamping Crimp, LD=车件插板式 Plug Panel, LM=车件贴板式 SMD  
LJ=车件屏蔽组装带螺丝接头 Shield Assembly Screw Joint  
LH=车件屏蔽压接接头 Shield Assembly Crimp Joint  
LP=车件屏蔽组装刺破式 Shield Assembly Pierce

7、对锁方式 Locking System

1=装配式 Assembled Type, 2=面板式 Panel Type, 3=注塑成型式 Injection Molding Type  
4=金属组装式 Metal Assembly Type 5=普通包胶式 (线) Rdnary Rubber-Coated Type (Wire)  
6=螺纹快速式 Thread Quick Type 7=法兰式 Flange Type 8=NAPIN卡扣式 SSnap-In Buckle Type



GENERAL TOLERANCES (UNLESS SPECIFIED)		DRAWN BY:	TITLE:
X.X ± 0.35	X.' ± 3'	Frank Zhou	M16 Series Male Solder Rear Fastened
X.XX ± 0.25	X.X' ± 2'	CHECKED BY:	PART NO.: MC16NM-XXR2LSLNS401
X.XXX ± 0.15	X.XX' ± 1'	Frank Zhou	DWG NO.: MC16NM-XXR2LSLNS401-P
THIRD ANGLE PROJECTION		APPROVED BY:	CUSTOMER:
		SCALE: NONE SHEET: 1 of 1	
DIMENSION STYLE MM ONLY	DESIGN UNITS METRIC	THIS DRAWING CONTAINS INFORMATION THAT IS PROPRIETARY TO SHUNKONN AND SHOULD NOT BE USED WITHOUT WRITTEN PERMISSION	

Website: www.connoder.com  
E-Mail: sale@Connoder.com  
CONNODER ELECTRONIC TECHNOLOGY CO LTD