

TECHNICAL DATA SHEET

SAFETY MATS SENSOR DT11 and DT15 series

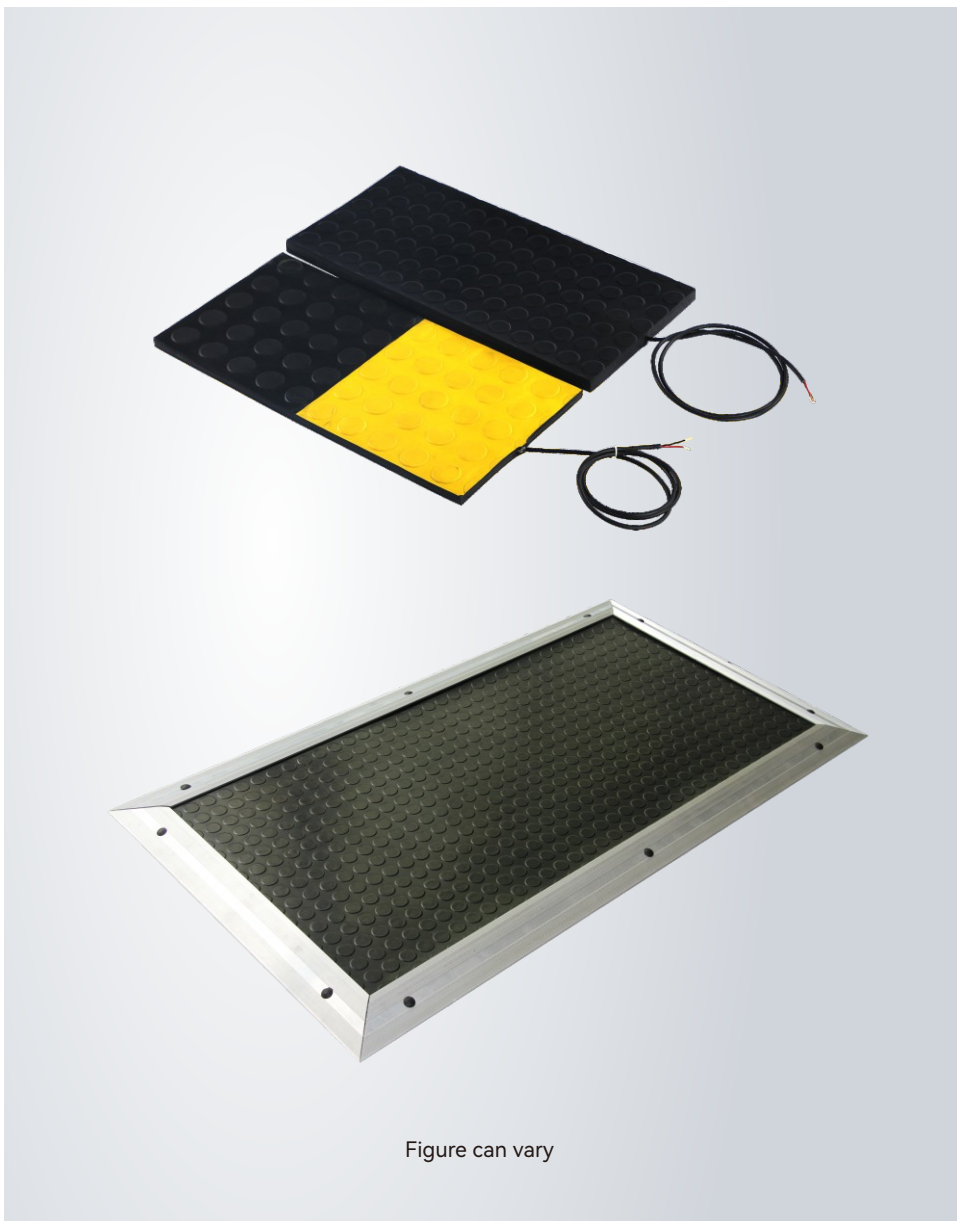

Contents

- Product Introduction
- Model specification
- Product features
- Protective performance
- Installation
- System configuration
- Precautions

Introduction to safety mats

The safety mat is a pressure-sensitive safety protection device. When a set minimum weight is exerted on the safety mat, the switch will turn off, and the controller will then send a stop signal to the protected machine to stop its movement. Reliably protect operators from various potential hazards. In industrial applications, it is a safety protection device for automatic equipment and meets the highest safety protection requirements. Provide necessary safety protection for personnel working in hazardous areas.

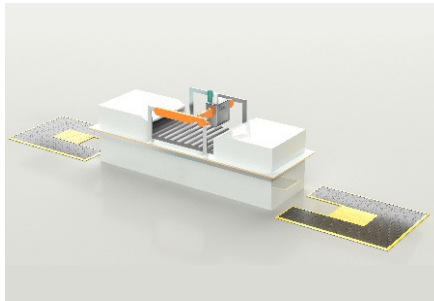
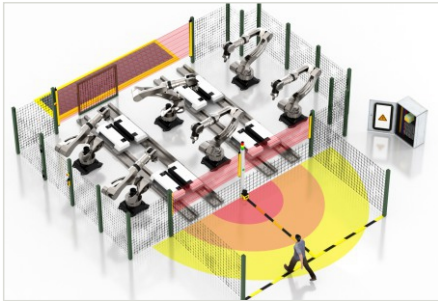

Advantages

- High trigger sensitivity, can provide safety protection for people weighing more than 20 kg;
- The laying area is flexible, and safety mat protection systems of different sizes or shapes can be customized according to user requirements;
- Different models can be selected to suit different working conditions and environmental conditions.



Use correctly

- Determination of working conditions in the installation area;
- Correct choice of paving area dimensions;
- The right choice for surface protective barrier layers;
- Correct installation method.

Safety mats user guide

Safety mats and matching safety relays form a control area. Each control unit can be a safety mat, or multiple safety mats connected in series to form a control area. Series use of safety mats Up to 6 safety mats can be connected in series. However, the maximum area of a control area shall not be greater than 6 square meters.

Scope of use restrictions

- Safety mats are not suitable for use in areas where personnel weighing less than 20 kg are inspected.
- Different types of safety mats are suitable for different applications. Please strictly follow the application scenarios specified in this manual to select the correct safety mats.
- Please follow this technical description to choose and use a matching safety relay. Different safety relays will affect the triggering sensitivity of the safety mat.
- Please configure the safety mats system according to this technical manual to ensure the functional safety of the safety mats system.

The specifications of DT series safety mats are as follows:

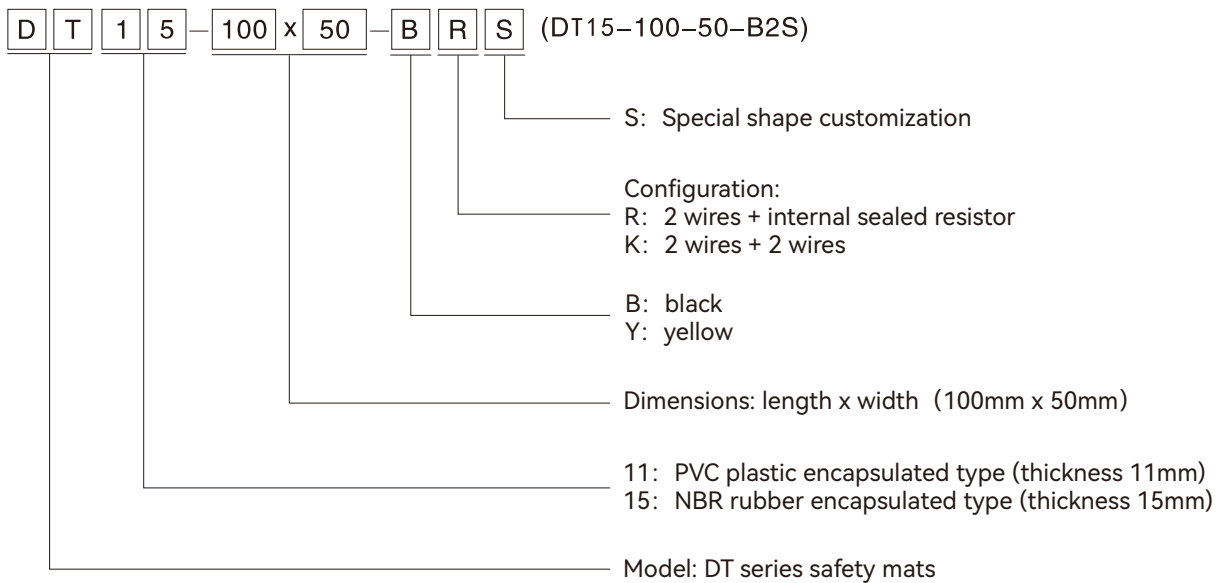

Technical data

Project	DT11	DT15
Adapt to detection range	The presence of people weighing more than 20KG	
Recommended use occasions	General working conditions	Special or heavy duty conditions
Usage environment requirements	Suitable for indoor use Ambient temperature range +5°C~+55°C	Suitable for indoor and outdoor use Ambient temperature range -10°C~+55°C
Safety mat thickness	11mm	15mm
Packaging materials	PVC	NBR rubber
Surface material	Yellow/Black PVC	black NBR rubber
Edge sealing form	Plug-in aluminum edge sealing	Shoulder-touch aluminum edge sealing
Precautions	Suitable for use in general working conditions Unable to withstand vehicle crushing and heavy object impact	Suitable for special or heavy working conditions Can withstand limited crushing by light vehicles and impact of ≥2KG heavy objects

Dimensions: length x width

300mm×300mm	750mm×750mm
400mm×400mm	1000mm×250mm
500mm×250mm	1000mm×500mm
500mm×400mm	1000mm×750mm
500mm×500mm	1000mm×1000mm
600mm×400mm	1500mm×500mm
750mm×250mm	1500mm×750mm
750mm×500mm	1500mm×1000mm

Note: Dimensions of outer edge including aluminum edge + 100mm.

The size of the safety mat is the net size without aluminum edges, and the dimensional error is ± 6mm.

Non-standard rectangular or special-shaped safety mats can be customized according to user requirements. The rectangular safety mat can be customized with a single side length ≤ 3m and a width ≤ 1m to ≤ 1.5m; the customizable types of special-shaped safety mats are as shown in the table below.

Classification and restrictions of customized special-shaped safety mats

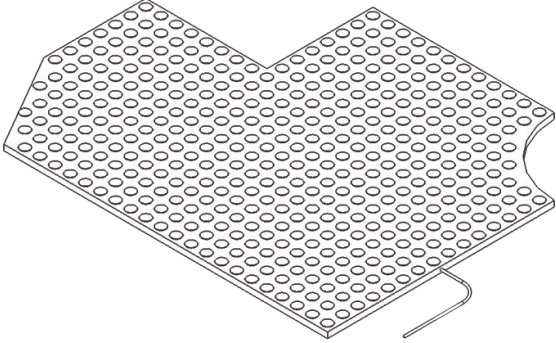
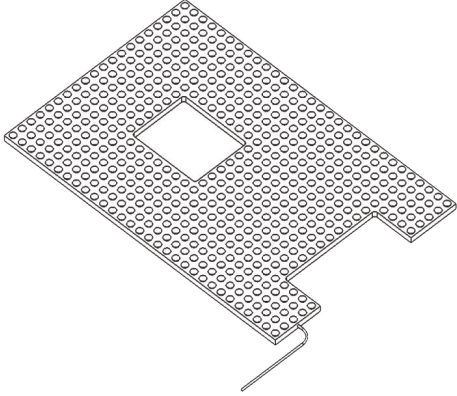
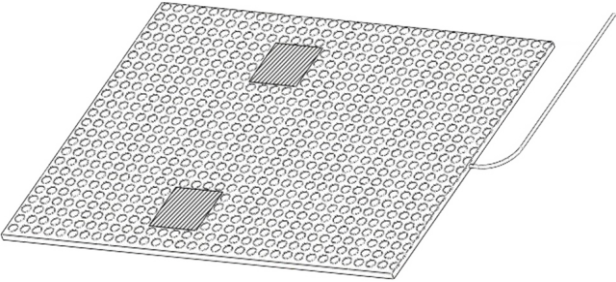
Type	Shape	Limit
Special shaped safety mat		Non-straight edge non-sensing area width 25mm signal cable cannot exit from hypotenuse or arc edge.
Partial opening safety mat		The width of the non-sensitive area at the edge of the middle opening is 25mm, and signal cables cannot exit from the middle hole.
local non-sensitive area safety mat		Set up a non-sensing area in the safety mat, and the distance between the non-sensing area and the edge of the safety mat should be greater than 200mm.

Safety mat product features

1. Effective size and edge non-sensing area

The effective area of the standard safety mat is: $L1 \times L2 \leq 1.5\text{m}^2$.

For protection areas $> 1.5\text{m}^2$, it is recommended to assemble multiple safety mats.

L1: Non-cable edge (wide edge)

L2: Cable side (narrow side)

The signal cable outlet is on the narrow side by default.

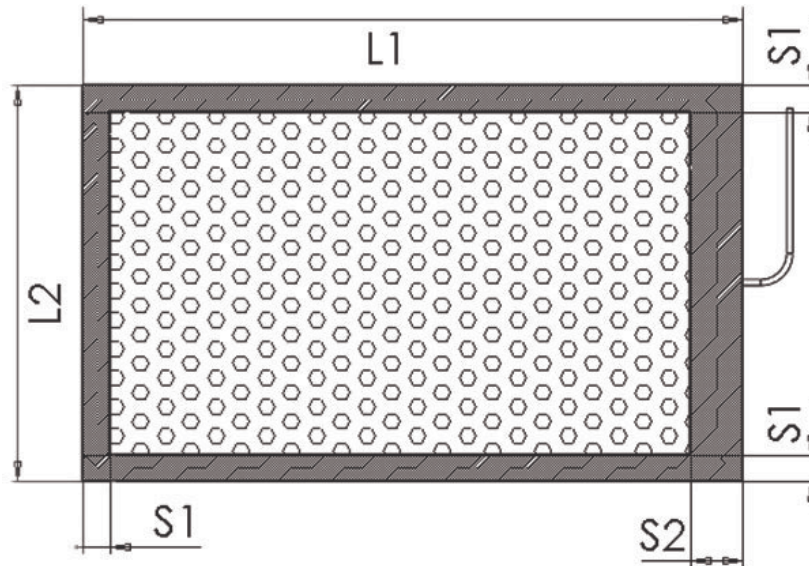

The edge of the safety mat package is a non-sensing area, and the edge non-sensing area does not have sensing function.

S1 = 10 mm non-cable outlet

S2 = 20 mm signal cable outlet

Note: When multiple safety mats are assembled into a modular safety mat, only the MATSof S1 can be joined to adjacent safety mats.

2. Safety mat functional categories and wiring

Quick plug safety mat

Quick plug K-type safety mat

Narrow end cable VVR $\phi 4\text{mm } 2 \times 0.2\text{mm}^2$
Cable length 0.1 meter.
The two wire ends are SCF and SCM plugs respectively.

Outline safety mat

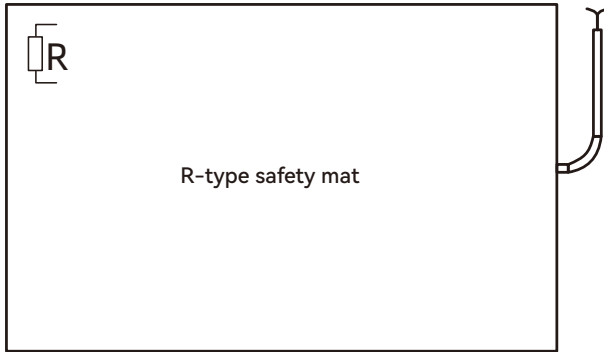

R-type safety mat

Two-core black TPE sheathed cable VVR $\phi 4\text{mm } 2 \times 0.35\text{mm}^2$ (red, black) cable length 5 meters, internal package termination resistance ($R = 1.2\text{K}\Omega$ or $8.2\text{K}\Omega$). R-type safety mats can be used alone or as terminal components in series with K-type safety mats.







K-type safety mat



2 two-core black TPE sheathed cables VVR $\phi 4\text{mm } 2 \times 0.35\text{mm}^2$ (red, black) cable length 2 meters.

3. Safety mat attachment accessories

(Applicable to quick-plug mats)

Terminal resistor ST-1.2		Single-sided connector cable (female) SCF-3 SCF-5 SCF-10	
Bilateral connection plug-in cable SCP-2 SCP-5		Single-sided connector cable (male) SCM-5	

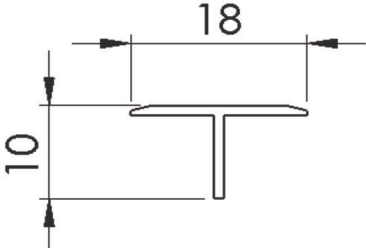
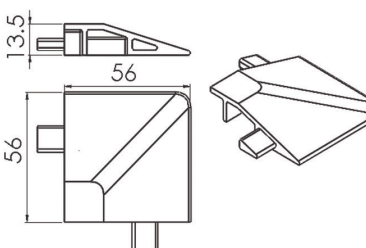
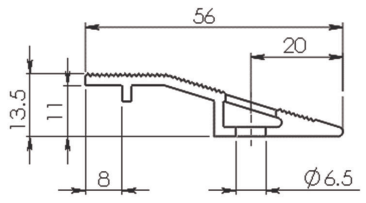
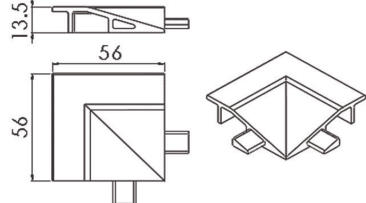
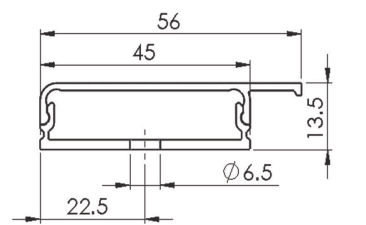
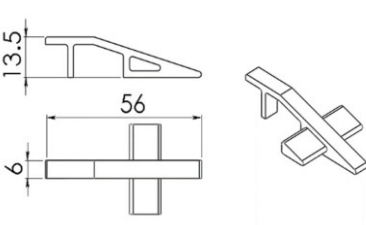
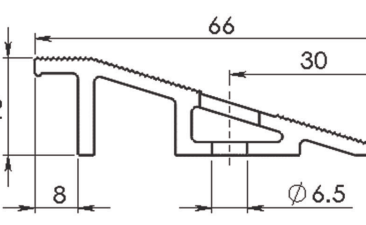
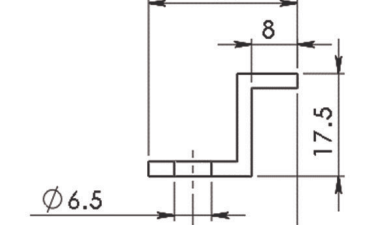
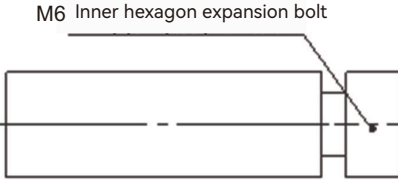
4. Safety mat installation accessories

11/15mm T-shaped edge		11mm sloped edge outer right-angle insert	
11mm Slope type edge press		11mm sloped edge inner right angle insert	
11mm Wire trough type edge press		11mm sloped edge direct connection plug-in	
15mm Slope type edge press		11/15mm Z-shaped edge	
Inner hexagon expansion bolt	 <p>M6 Inner hexagon expansion bolt</p>	Dust cover	

Protective layer barrier performance

The safety mat protective layer has good physical and chemical barrier properties and has a certain mechanical protection effect.

Material. The surface layer has excellent anti-skid properties. According to the use environment and working conditions, the selected protective layer has anti-skid, oil-resistant and corrosion-resistant functions.

1. Physical barrier properties of protective layer

Project (23°C)	DT11 PVC surface layer	DT15 NBR surface layer
Upper surface	Anti-slip surface of copper coins	Anti-slip surface of copper coins
Protection level (IEC60529)	IP65/IP67	IP65/IP67
Shore A hardness	80 ± 5 degrees	65 ± 5 degrees
Wear (DIN 53516)	<150mg	<150mg
Anti-slip (DIN 51130)	R9	R9
Maximum load capacity (8 hours)	200N/cm ²	400N/cm ²
Fire protection rating (DIN 4102)	B2	B2

2. Chemical barrier properties of protective layer

Solution name	DT11	DT15	Solution name	DT11	DT15
Dilute acid	+	+	Liquid ammonia	+	+
Dilute alkali	+	+	Brake fluid	+	±
Non oxidizing acid	+	+	Cutting emulsion	+	+
Metal processing oil	+	+	Acetic acid	+	+
Vegetable oil	+	+	Acetone	-	+
Ester solvents	-	-	Potash fertilizer	±	±
Solvent (gasoline)	-	±	Methanol	+	+
Aromatic hydrocarbons	-	-	Diluent	-	-
Alcohol	+	+	Soapy water	+	+
Water	+	+			

Note: + Resistance ± Weak Resistance - Ineffective Resistance

3. Technical standard

Safety mat type DT11/DT15 and safety relay LS-A		
Test principle: EN 1760-1,ISO 13856-1		
Model	DT11	DT15
Detection method	Pressure sensing method	Pressure sensing method
Minimum trigger weight	20kg	20kg
Maximum allowable load (8 hours)	$\leq 200\text{N/cm}^2$	$\leq 400\text{N/cm}^2$
Mechanical life	> 1,000,000times	> 3,000,000times
Edge length min/max	200mm/3000mm	200mm/3000mm
Packaging materials	PVC	NBR
Surface protective layer	PVC	NBR
Status of use	+5°C~ +55°C	-10°C~ +55°C
Storage state	-20°C~ +65°C	-20°C~ +65°C
Safety mat working voltage	$\leq 5\text{V DC}$	
Safety mat operating current	$\leq 100\text{mA}$	
Protection level	IP65/IP67 (Customizable)	
Maximum humidity (23°C)	95% (Condensation)	
Response time	18ms	

Security classification	
EN 1760-1 Reset command	Support
ISO 13849-1 : 2015	Cat.3
MTTFd	> 30 year
B10d	3×10^7
Nop (accept)	52560/year
IEC 61508 : PFHS	$6.99 \times 10^{-10} / \text{h} (\text{SIL3})$

The safety protection system composed of DT11/DT15 safety mat and Ter-A series safety relays meets the following standards:
 EN1760-1 ISO13856-1 EN62061 EN ISO13849-1 IEC61508 EN60204-1

Safety mat installation

- Open the package: Take out the safety mat and installation accessories, check whether the contents of the package are consistent with the provided packaging list, and check whether the safety mat is intact.
- Prepare the installation site: The installation site must be flat, and there should be no holes or protrusions on the installation floor. Any floor defects can cause damage to the safety mat or loss of safety features.
- Remove dirt and ice from the installation floor and ensure the surface is dry.
- Use an ohmmeter to check the resistance at both terminals of each safety mat: Type R safety mat ohmmeter indicates 1.2KΩ to 1.5KΩ. K-type safety mat ohmmeter measures 2 red wires or 2 black wires individually as NO. Red-black line is OFF.

Follow these steps to install safety mat:

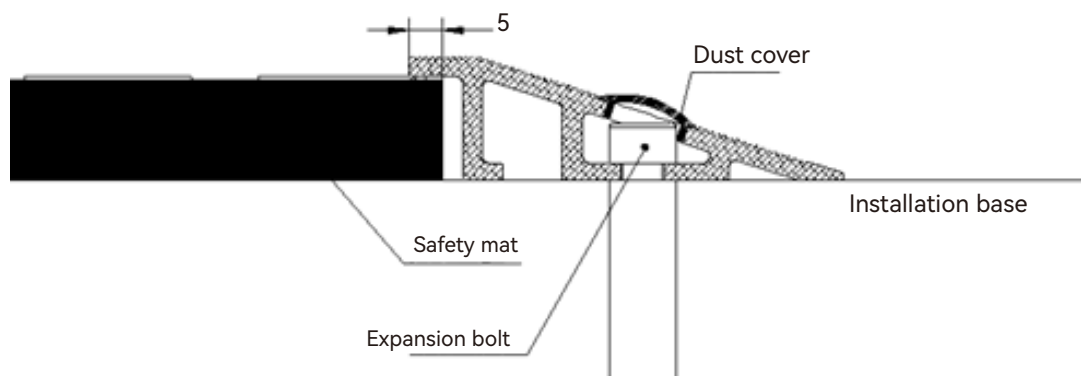

1. After arranging the safety mat at the determined location according to the usage requirements, determine the position of the aluminum edge according to the dimensions in the figure below.
2. Drill holes on the surface of the installation base according to the position of the mounting holes on the aluminum edge. Clean the dust on the aluminum flange, foundation surface and drilled holes (use a vacuum cleaner). Otherwise, the dust from the drilled holes will be on the safety pad and aluminum seal. It causes unevenness under the edge.
3. Place the aluminum crimp again and fix the aluminum crimp on the outlet side of the safety mat.
4. Pass the wire through the wire outlet of the aluminum crimp, and fix the aluminum crimp on the other three sides.
5. Lay and wire the safety mats used in series in each area, and connect the signal cables to the safety relays in the control cabinet.



- Connect the safety mat connection safety relay to the machine's control system according to the system configuration.

Note: The cable is only used for signal output. The cable must not be dragged and positioned during the installation of the safety mat.

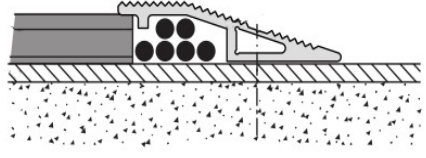
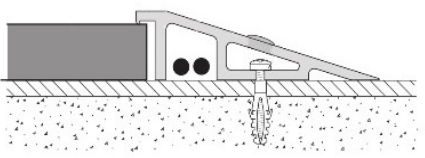
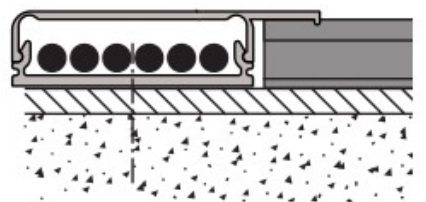
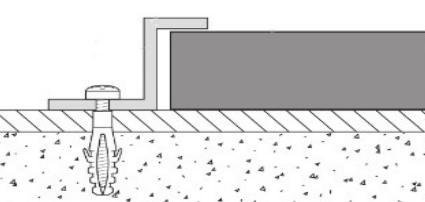
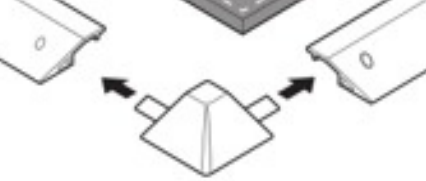
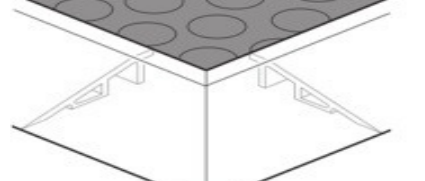
- Depending on the operating conditions and the type of safety mat selected, different types of safety mats use different installation accessories. For the installation methods of different configurations of installation accessories, see the following illustrations.

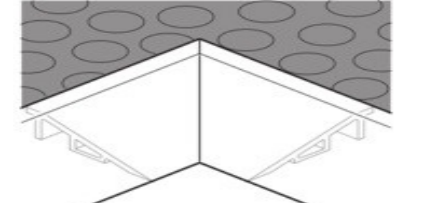
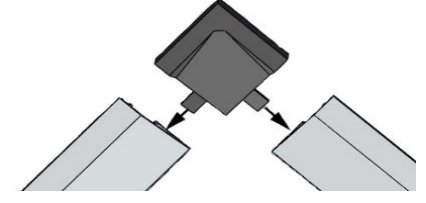
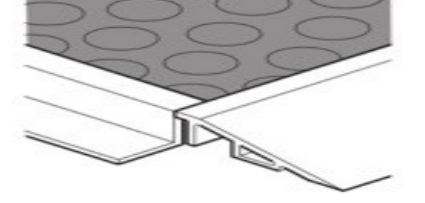
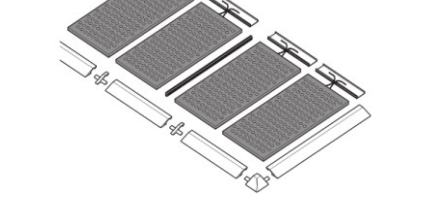
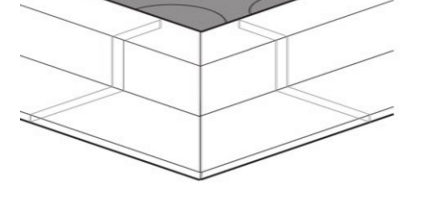
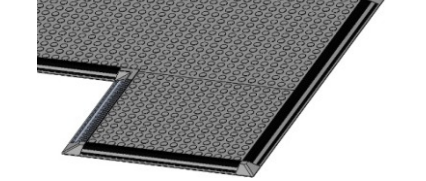
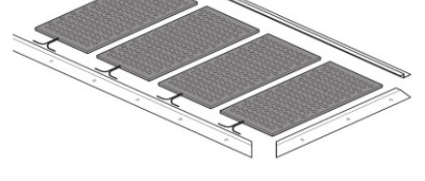
DT11 type safety mat installation diagram		DT15 type safety mat installation diagram	
DT11 type Press edge installation		DT15 type Press edge installation	
DT11 type Wire trough edge installation		DT15 type Z-shaped edge installation	
DT11 type Press edge outer corner plug-in installation		DT15 type Installation of outer corner press edge and shoulder corner joint	
DT11 type Press edge plug installation		DT15 type Installation of inner corner press edge and shoulder corner joint	
DT11 type Press edge inner corner plug installation		DT15 type Edge holder and Z-shaped edge holder installation	
DT11 type Installation of splicing and crimping		DT15 type Z-shaped edge pressing shoulder corner joint	
DT11 type Special-shaped splicing and edge installation		DT15 type Installation of splicing and crimping	

1. Design specifications for the use of safety mats, calculation and selection of sensing areas

Safety design of safety mat protection area Safety relay should adopt manual reset mode to ensure the personal safety of personnel.

According to the EN 999 standard, the effective sensing area set up in the hazardous area can be calculated according to the following formula:

$$S = (K \times T) + C$$

In the formula: $K = 1600 \text{ mm/s}$

$$T = t_1 + t_2$$

$$C = 1200 \text{ mm} - 0.4H$$

When the safety mat is installed on the ground level: $H = 0$

$$S = (1600 \text{ mm/s} \times T) + 1200 \text{ mm}$$

When safety mat is installed on steps: $H \neq 0$

$$S = (1600 \text{ mm/s} \times T) + (1200 \text{ mm} - 0.4H)$$

In the formula:

S -- the minimum distance between the danger zone and the farthest corner of the safety mat [mm]

K -- Approximate parameter [mm/s]

T -- time to pass safety mat [S]

t_1 -- Response time of safety mat system [S]

t_2 -- Stop time of the machine drive system [S]

C -- Safety margin [mm]

H -- Stair height [mm]

2. Calculation example

Example 1

The safety mat is installed in an area where automatic machines are not allowed to enter. This area is ground level, so $H = 0$.

The response time for passing the safety mat is 300 ms, and the stop time of the drive system is 30 ms.

$$S = (1600 \text{ mm/s} \times (300 \text{ ms} + 30 \text{ ms})) + 1200 \text{ mm}$$

$$S = 528 \text{ mm} + 1200 \text{ mm}$$

$$S = 1728 \text{ mm}$$

Safety mat work areas are only prone to the occasional accidental drop of a small tool during maintenance.

Based on the above working conditions and calculation data, select the safety mat model:

DT11-1500*750-B2

Example 2

The regional conditions are the same as Example 1. There is a staircase with a height of 150 mm, and the dangerous area must be passed quickly.

$$S = 1600 \text{ mm/s} \times (300 \text{ ms} + 30 \text{ ms}) + (1200 - 0.4 \times 150) \text{ mm}$$

$$S = 528 \text{ mm} + 1120 \text{ mm}$$

$$S = 1648 \text{ mm}$$

The safety mat working area is under heavy forging conditions, and heavy objects may occasionally fall in the safety mat area during normal operation.

Based on the above working conditions and calculation data, the safety mat model is selected as:

DT15-1500*750-B2

Safety mat system configuration

1. Sensing Mode Safety Relay

Our safety relays Ter-A series are sensing mode safety relays. The safety mat system composed of the safety mat and the above safety relay complies with the EN1760-1 ISO13856-1 En62061 IEC61508 ISO13849-1 EN60204-1 standard.

The control principle diagram of safety mat safety protection is as follows:

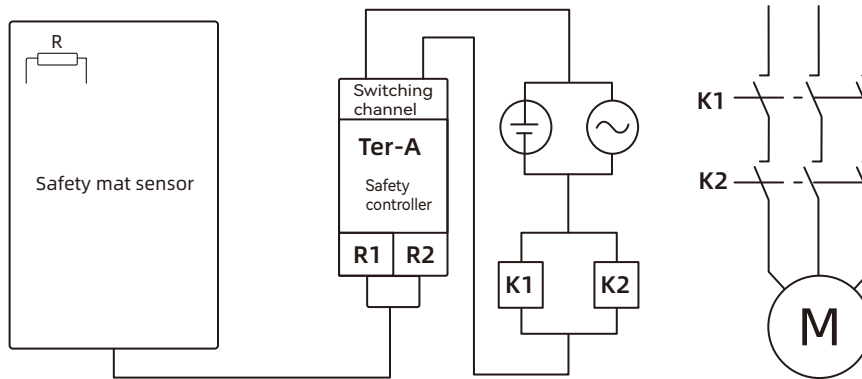

According to the areas that need to be protected, several safety mats can be connected in series to form a protective area.

The following combinations can be selected based on actual installation conditions and needs:

2. Sensing output - R/K and K/K series combination of safety mats

This combination is generally used in sensing output mode and when multiple safety mats are assembled in a single area. The area of a single area allowed for this splicing method is $\leq 8 \text{ m}^2$.

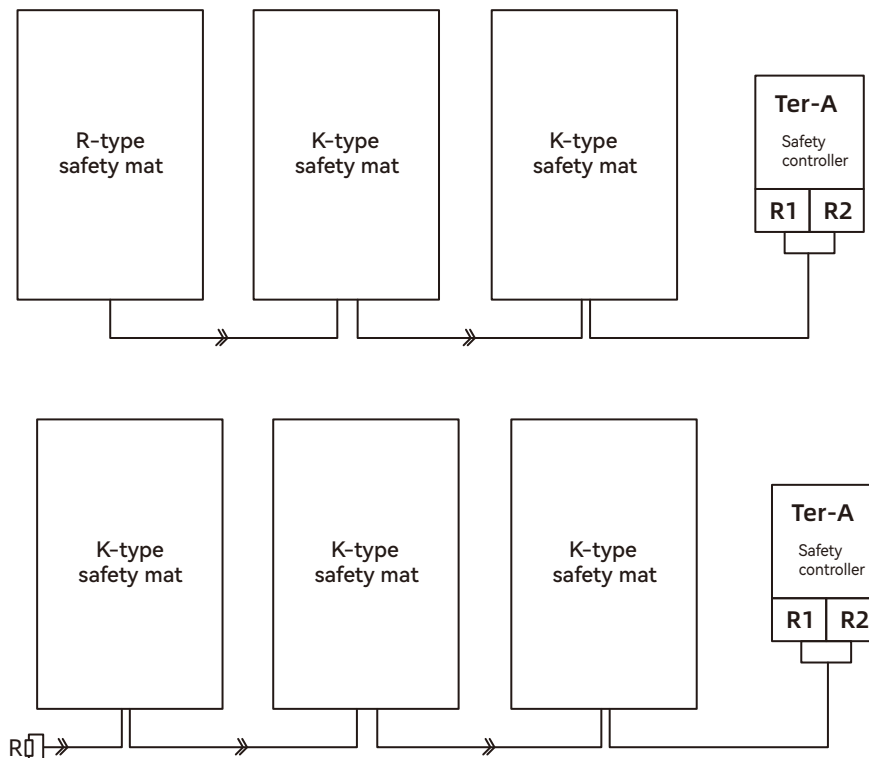

Precautions

1. Selection considerations

Selection factors	DT11 PVC safety mat	DT15 NBR surface layer
Working conditions	Use under general working conditions	Use in heavy duty conditions
Ambient temperature	+5°C~ -55 °C	-10°C ~ -65 °C
Oil pollution	Oil or dust will reduce the anti-slip performance of the safety mat	Suitable for use in environments with oil and dust
Carrying capacity	Low load-bearing capacity and cannot withstand rolling loads	High load-bearing capacity, can withstand light rolling loads

2. Storage and installation precautions

Various actions will cause damage to your safety mat:

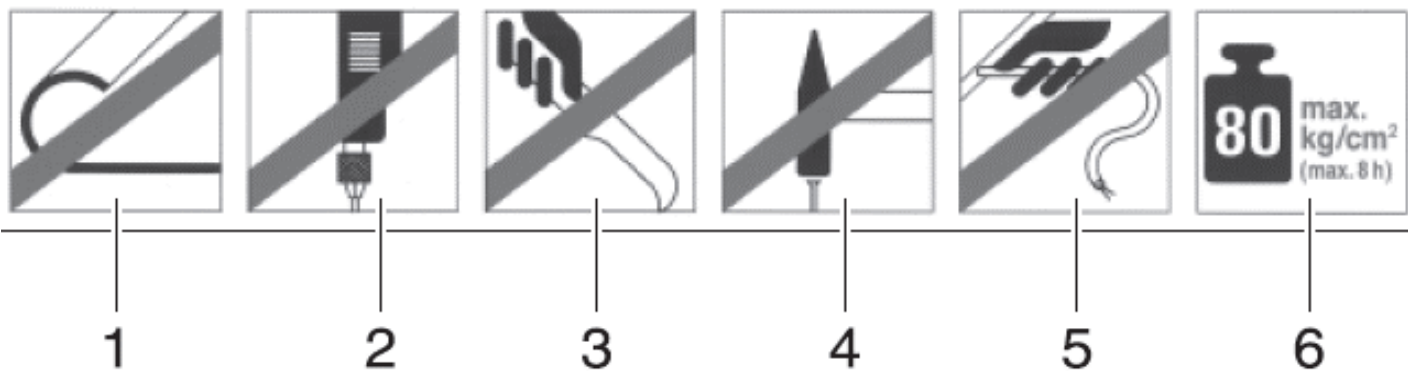

1. The safety mat must not be curled during use, installation and transportation.
2. Do not drill or cut holes in the safety mat.
3. Safety mats cannot be cut and used.
4. Do not hammer or drive nails (screws) into the safety mat.
5. Do not drag cables to move or carry safety mats.
6. Do not place excessively heavy objects on the safety mat for a long time.
The maximum load capacity is 80Kg/cm² (8 hours).

3. Precautions for use

The safety mat cannot be directly connected to the ordinary intermediate relay switch contacts.
Be sure to choose safety mats and safety relays with safety function certification.
Be sure to use the safety mat with the matching safety relay in these instructions.
Please check regularly whether the safety mat is working properly to ensure its safety function.
Please replace safety mats that have exceeded their service life in time.
Please replace the safety mat with damaged surface protective layer in time.

4. Warranty Notes

Requires installation according to technical instructions and use safety mats.
It needs to be used with the safety relay produced by our company or recognized by our company.
Need to be defined according to the working conditions in the product manual.
It is necessary to protect the safety mat sealing layer from damage.
It is necessary to protect the safety mat from bending or folding during use, transportation and storage.
Safety mat cables need to be protected and not towed.