

All materials, plating and process meet HF requirements.

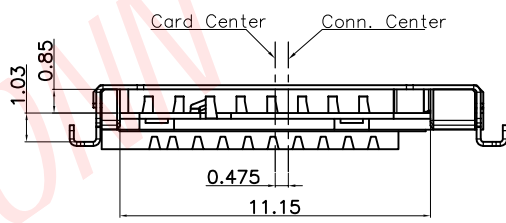
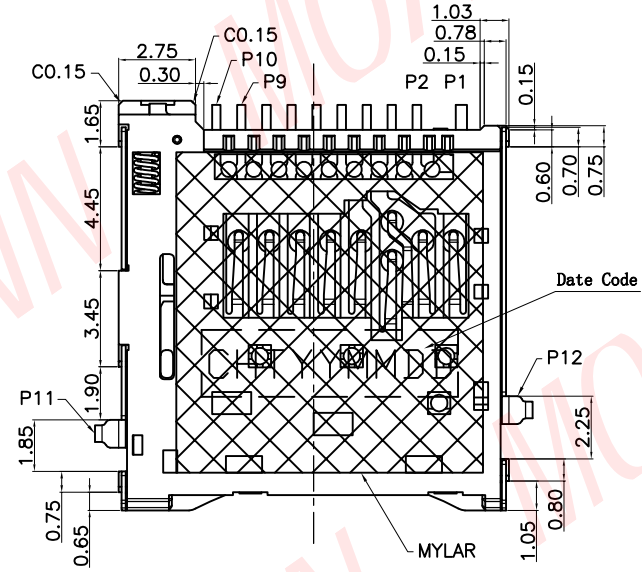
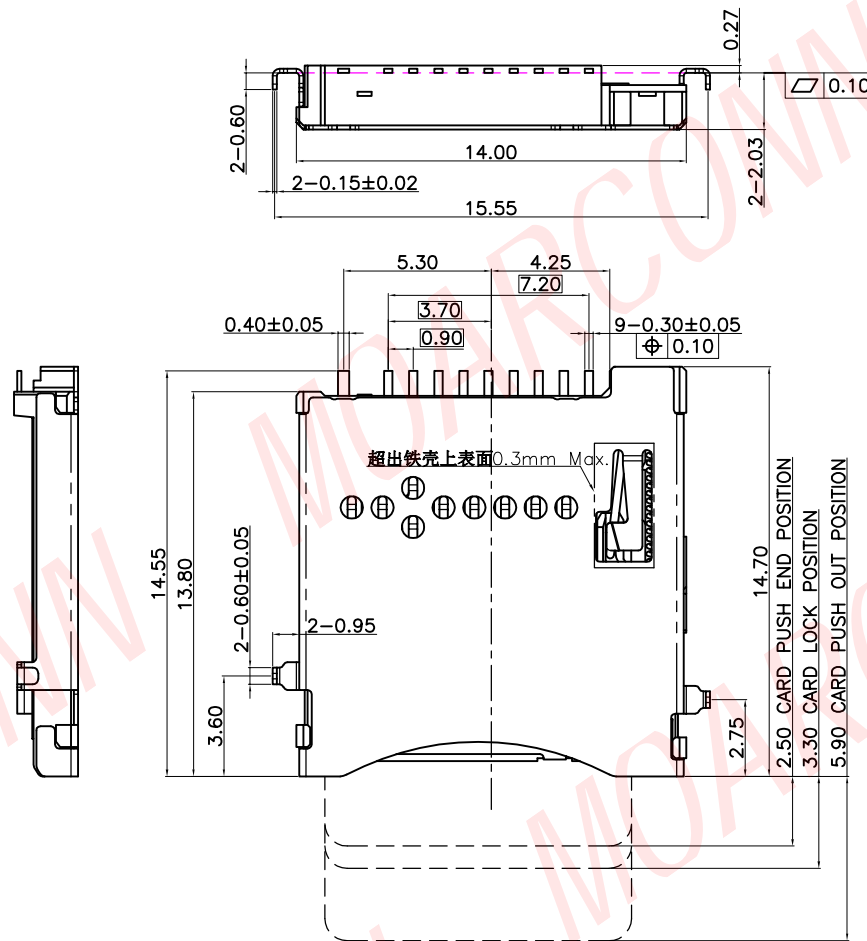

MOARCONN
MORE CONNECTIONS SMART FUTURE

DONG GUAN MOARCONN ELECTRONIC Co., Ltd.

DIMENSIONS INIT: mm UNLESS OTHERWISE SPECIFIABLE DIMENSION TOLERANCE X.X: ± 0.35 X.XX: ± 0.25 X.XXX: ± 0.10 ANGULAR: ± 2°	PRODUCT NAME : Micro SD P-P Sink H2.30	DRAWING: Faji	DATE: 2020.04.29
	PRODUCT NO. : MS230-T1250-01	CHECK:	DATE:
	DRAWING NO. : D-MS230-T1250-01	APPROVED:	DATE:
	SCALE: 1:1 DWG ID: C D REV.: A PAGE: 1 of 2		

A	---	NEW RELEASE	Faji	2020.04.29
REVISION NO.	ECR NO.	DESCRIPTION	MARK	DATE

All materials, plating and process meet HF requirements.

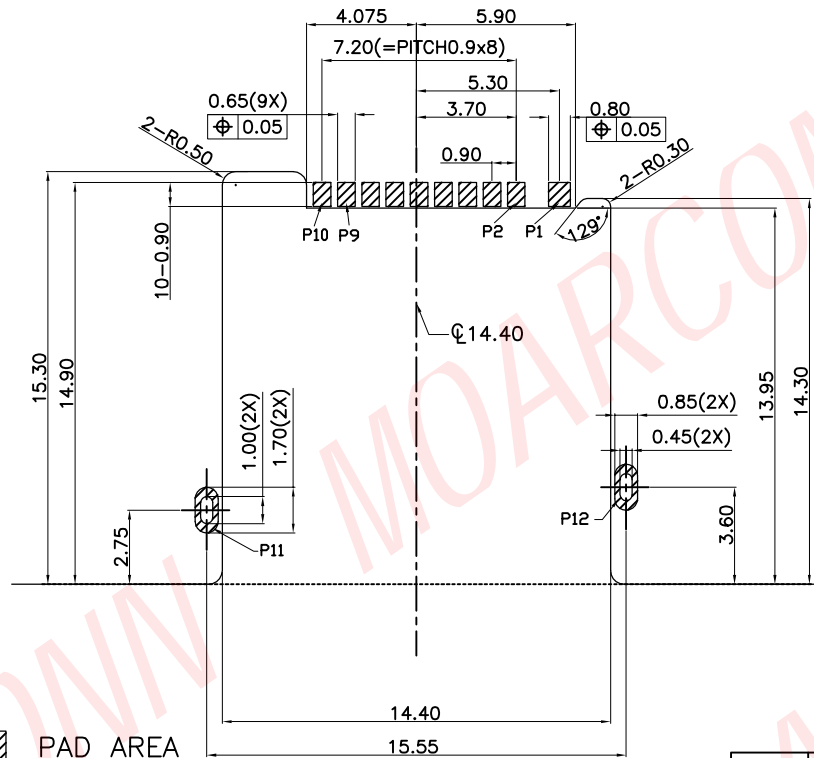

NOTE:

- 1.MATERIAL:
 - 1-1 PLASTICS: HEAT RESISTANCE POLYMER, UL94V-0,COLOR:BLACK
 - 1-2 CONTACT: COPPER ALLOY
 - 1-3 SHELL; STAINLESS STEEL
- 2.PLATING:
 - 2-1 CONTACT:
 - 2-1-1: CONTACT AREA: Au 1u" PLATING OVER Ni.
 - 2-1-2: SOLDER TAIL AREA: MATTE TIN 80u" MIN. OVER Ni. 30u" MIN
 - 2-2 SHELL: SOLDERABILITY Ni PLATING OVER ALL
- 3.CONTACT AND TAIL COPLANARITY TO BE 0.10mm MAX.
- 4.PART MUST COMPLY TAI SOL HF WD-3-1-09I SOPECIFICATION
- 5.RECOMMENDING A METAL MORE THAN 0.10 THICK.
PLEASE CONFIRM SOLDILITY, IF USE A METAL MASK LESS THAN 0.10mm THICK.
- 6.PRODUCT PACKING: PLEASE REFER TO THE PACKING REGULATION

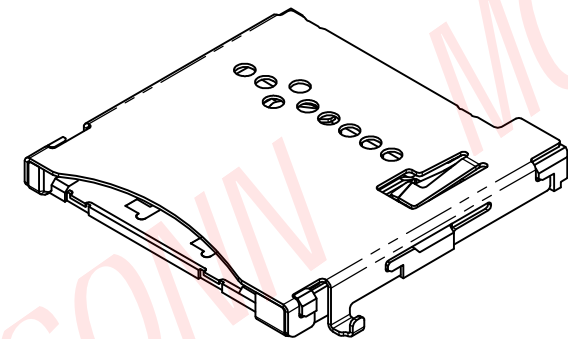

Recommended P.C.B LAYOUT
BOTTOM VIEW(CONNECTOR) (TOLERANCE+/-0.05)
TOP VIEW(SYSTEM)

Opening/Close of Switch

Card Detect Switch	
Card Uninsertion	Open
Card Half Insertion	Open
Card Insertion	Close
N/O	<div style="display: flex; justify-content: space-around;"> <div>Open </div> <div>Close </div> </div>

Pin No.	Pin Assignment
P1	MICRO SD CD
P2	MICRO SD DAT1
P3	MICRO SD DAT0
P4	MICRO SD VSS
P5	MICRO SD CLK
P6	MICRO SD VDD
P7	MICRO SD CMD
P8	MICRO SD CD/DAT3
P9	MICRO SD DAT2
P10	MICRO SD GND
P11	MICRO SD GND
P12	MICRO SD GND

MOARCONN
MORE CONNECTIONS CHART FUTURE

DONG GUAN MOARCONN ELECTRONIC Co., Ltd.

DIMENSIONS INIT:	mm
UNLESS OTHERWISE SPECIFIABLE	
DIMENSION	TOLERANCE
X.X: ±	0.35
X.XX: ±	0.25
X.XXX: ±	0.10
ANGULAR: ±	2'

PRODUCT NAME :	Micro SD P-P Sink H2.30	DRAWING:	Faji	DATE:	2020.04.29
PRODUCT NO. :	MS230-T1250-01	CHECK:		DATE:	
DRAWING NO. :	D-MS230-T1250-01	APPROVED:		DATE:	
SCALE:	1:1	DWG ID:	C D	REV.:	A
				PAGE:	2 of 2

A	-----	NEW RELEASE	Faji	2020.04.29
REVISION NO.	ECR NO.	DESCRIPTION	MARK	DATE
1				