

All materials, plating and process meet HF requirements.

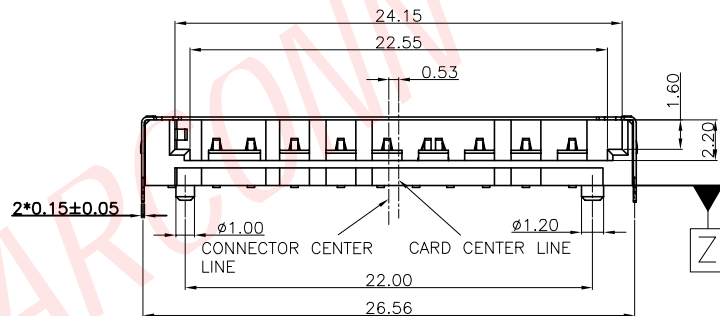
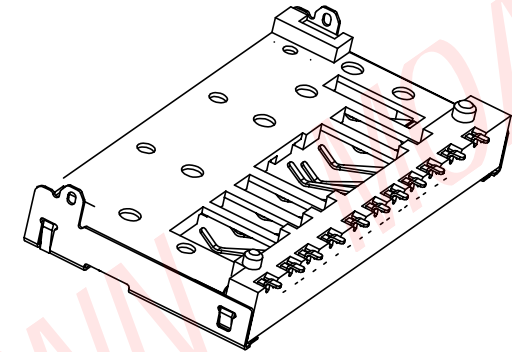
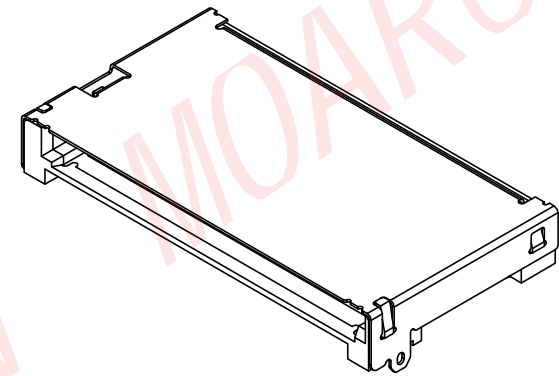
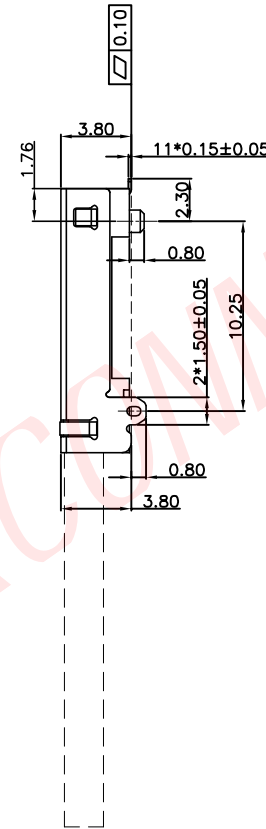
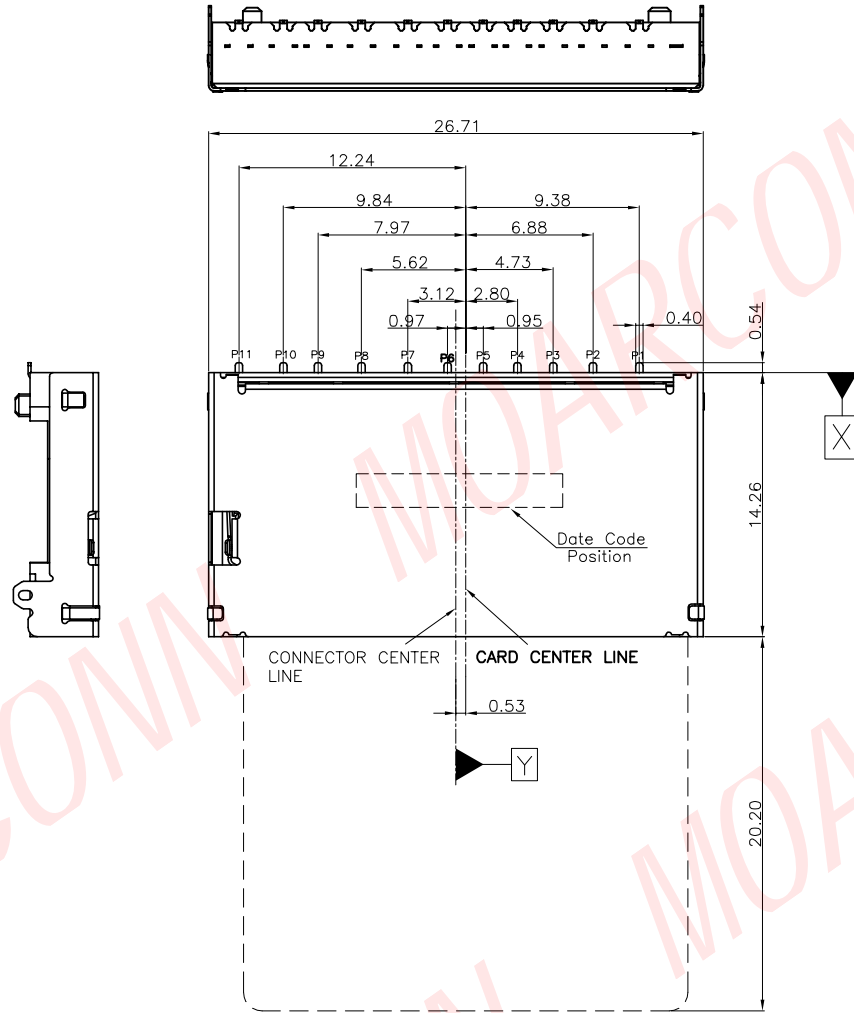

		<b>DONG GUAN MOARCONN ELECTRONIC Co., Ltd.</b>				
		PRODUCT NAME : SD CARD CONN. STAND OFF 1.0mm H3.8mm	DRAWING: janyz	DATE: 2019.04.19		
DIMENSIONS INIT: mm UNLESS OTHERWISE SPECIFIABLE		PRODUCT NO. : SDE-T1250-31	CHECK:	DATE:		
DIMENSION TOLERANCE X.X: ± 0.38 X.XX: ± 0.25 X.XXX: ± 0.10 ANGULAR: ± 3°		DRAWING NO. : D-SDE-T1250-31	APPROVED:	DATE:		
			SCALE: 1:1	DWG ID: C D	REV.: A	PAGE: 1 OF 2

A	----	NEW RELEASE	janyz	2019.04.19
REVISION NO.	ECR NO.	DESCRIPTION	MARK	DATE
1		2	3	4

A  
B  
C  
D  
E  
F

All materials, plating and process meet HF requirements.

NOTES :

- Material:
  - Insulator: High Temperature Thermoplastic, (LCP, S475), UL Black 94V-0.
  - Contact: Phosphor Bronze (C5191-EH, T=0.15±0.05mm)
  - Shell: SUS304-3/4H, T=0.15±0.05mm
- Plating:
  - Contact: Plated 50u"min Ni Overall  
Plated 1u"min Au Selective Contact Area  
Plated 80u"min Sn over Ni on solder area
  - Shell: Plated 50u"min Ni Overall
- Property:
  - Current Rating :0.5A AC/DC
  - Voltage Rating :250VRMS
  - Dielectric Withstanding Voltage: AC 500V r.m.s.
  - Insulation Resistance: 1000MΩ minimum.
  - Contact Resistance: 100mΩ maximum
  - Operating Temperature: -25°C~90°C
- Part Must Comply Taisol HF WD-3-I-091 Specification.
- Recommending A Metal More Than 0.15mm Thick. Please Confirm Solderability, IF Use A Metal Mask Less Than 0.15mm Thick.
- Packing Specification NO: P-9A212.

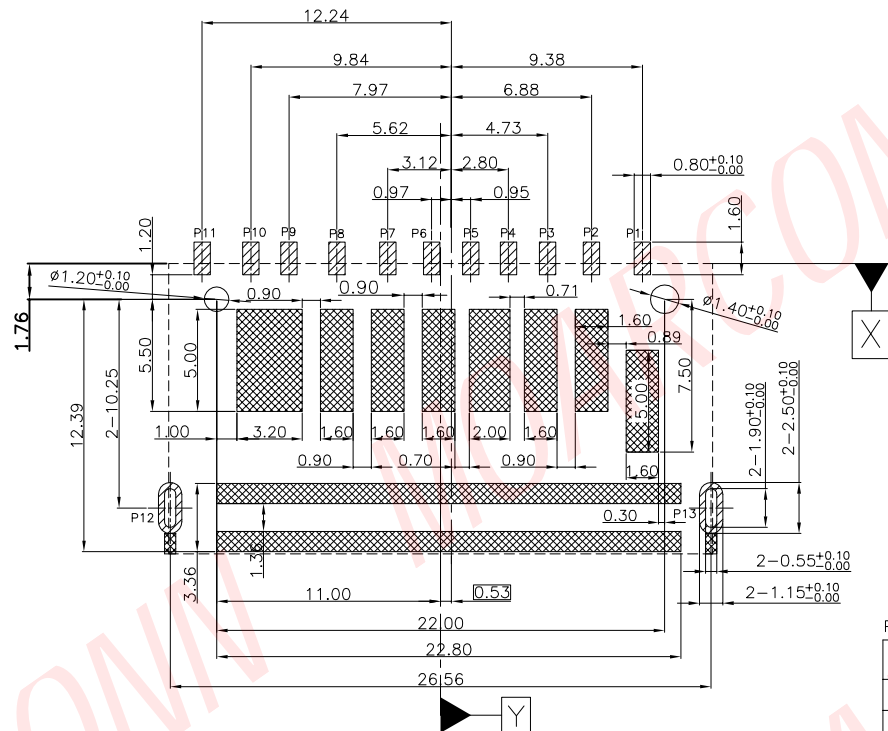

RECOMMEND P.C.B LAYOUT TOLERANCE ±0.05

- PAD
- No trace, no test point, no via hole, no ground area

Connector Pin No.	SD Card Pin No.	Pin Define
P1	P9	DAT2
P2	P1	DAT3
P3	P2	CMD
P4		CD
P5	P3	VSS1
P6	P4	VDD
P7	P5	CLK
P8	P6	VSS2
P9	P7	DAT0
P10	P8	DAT1
P11		W/P
P12~P13		GND

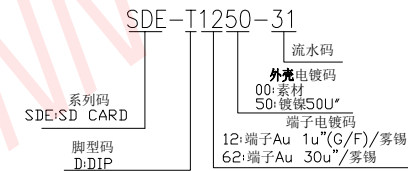

WITHOUT CARD		CARD INSERTED:LOCK		CARD INSERTED:UNLOCK	
W/P	GND	W/P	GND	W/P	GND
C/D	VSS1	C/D	VSS1	C/D	VSS1

	DONG GUAN MOARCONN ELECTRONIC Co., Ltd.			
	DIMENSIONS INIT: mm UNLESS OTHERWISE SPECIFIABLE DIMENSION TOLERANCE X.X: ± 0.38 X.XX: ± 0.25 X.XXX: ± 0.10 ANGULAR: ± 3°	PRODUCT NAME : SD CARD CONN. STAND OFF 1.0mm H3.8mm PRODUCT NO. : SDE-T1250-31 DRAWING NO. : D-SDE-T1250-31	DRAWING: janyz CHECK: APPROVED: SCALE: 1:1 DWG ID: C D REV.: A	DATE: 2019.04.19 DATE: DATE: PAGE: 2 OF 2

A	-----	NEW RELEASE	janyz	2019.04.19
REVISION NO.	ECR NO.	DESCRIPTION	MARK	DATE
1				