

RG-1A Electric & Hydraulic Roll Grooving Machine

Explosive view & part list

Standard Machine Set

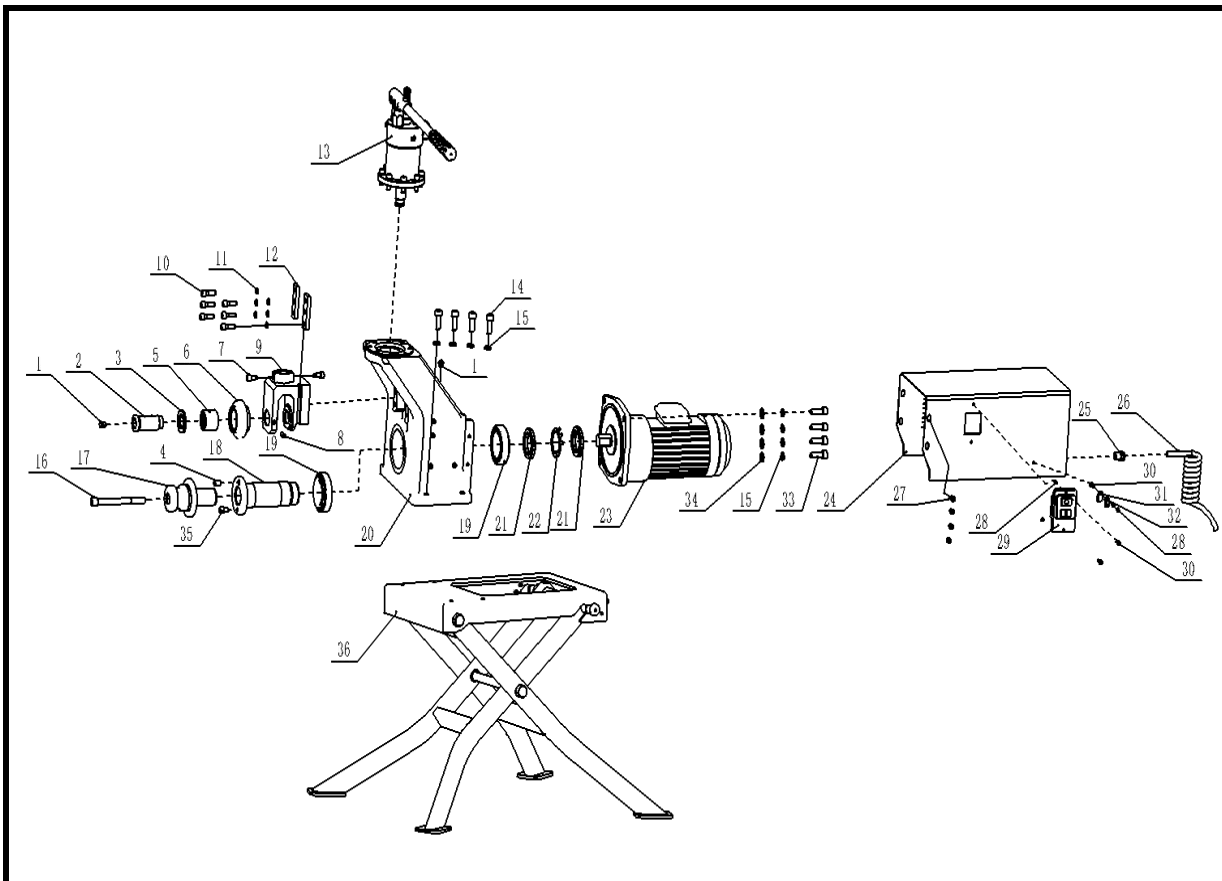

No.	Item Code	Specification	No./ Unit	Type	Note
1	15027	grease nuzzle	2	* std. parts	
2	11046	groove shaft	1	** machined	
3	15002	roller bearing	3	*** bearing	
4	15106	pin $\phi 10 \times 18$	1	* std. parts	
5	15003	roller bearing	3	*** bearing	
6	12011	^ groove roller 1" ~ 1½"	1	*** roller	
6	12012	^ groove roller 2" ~ 6"	1	*** roller	
6	12013	^ groove roller 8"	1	*** roller	
7	19040	piston fix screw	2	** machined	
8	15115	set screw	1	* std. parts	
9	18006	slide block	1	** machined	
10	15046	hex screw	6	* std. parts	
11	15074	spring washes	6	* std. parts	
12	13015	slide key	2	** machined	
13	98009	hydraulic pump GHM-1A	1	** asselbly	
14	15076	hex set screw	4	* std. parts	
15	15078	spring washer	16	* std. parts	
16	15004	drive roller bolt	1	* std. parts	
17	11042	drive roller 1" ~ 1½"	1	*** roller	
17	11043	drive roller 2" ~ 6"	1	*** roller	

RG-1A Electric & Hydraulic Roll Grooving Machine

Explosive view & part list

17	11044	drive roller 8"	1	*** roller	
18	11047	main drive shaft	1	** machined	
19	15001	roller bearing	2	*** bearing	
20	10004	housing	1	* casting	
21	15107	nut	2	* std. parts	
22	15108	lock washer	1	* std. parts	
23	98007	thress phase motor	1	** motor	alternative
23	98008	single phase motor	1	** motor	alternative
24	14005	motor cover	1	** machined	
25	15130	cable plug	1	** electric	
26	15087	electric cable (3mtrs)	3	** electric	
27	15080	hex screw	4	* std. parts	
28	15084	hex screw	4	* std. parts	
29	15085	power switch	1	** electric	
30	15083	pan head screw	3	* std. parts	
31	15197	cable clip	1	* std. parts	
32	15196	ground cable plate	1	*std. parts	
33	15076	hex set screw	4	*std. parts	
34	15075	flat washer	12	*std. parts	
35	15105	hex screw	1	* std. parts	
36	21040	folk arm machine support	1	** machined	
/	98026	foot switch	1	** electric	optional
/	98033	pipe stabilizer	1	** asselbly	optional
/	98078	pipe stand 1"~12"	1	** asselbly	

**Remark ^: Groove roller only works with #15002 & #15003 roller bearings.
Each roller requires 2 bearings.**

Spare part recommendation:

Type * No need for inventory, can be found at local market or covered in warranty;

Type ** Small local inventory recommended for missing/ physical damage;

Type *** Local inventory recommended for replacing;

RG-1A Electric & Hydraulic Roll Grooving Machine

Explosive view & part list

Hydraulic Pump

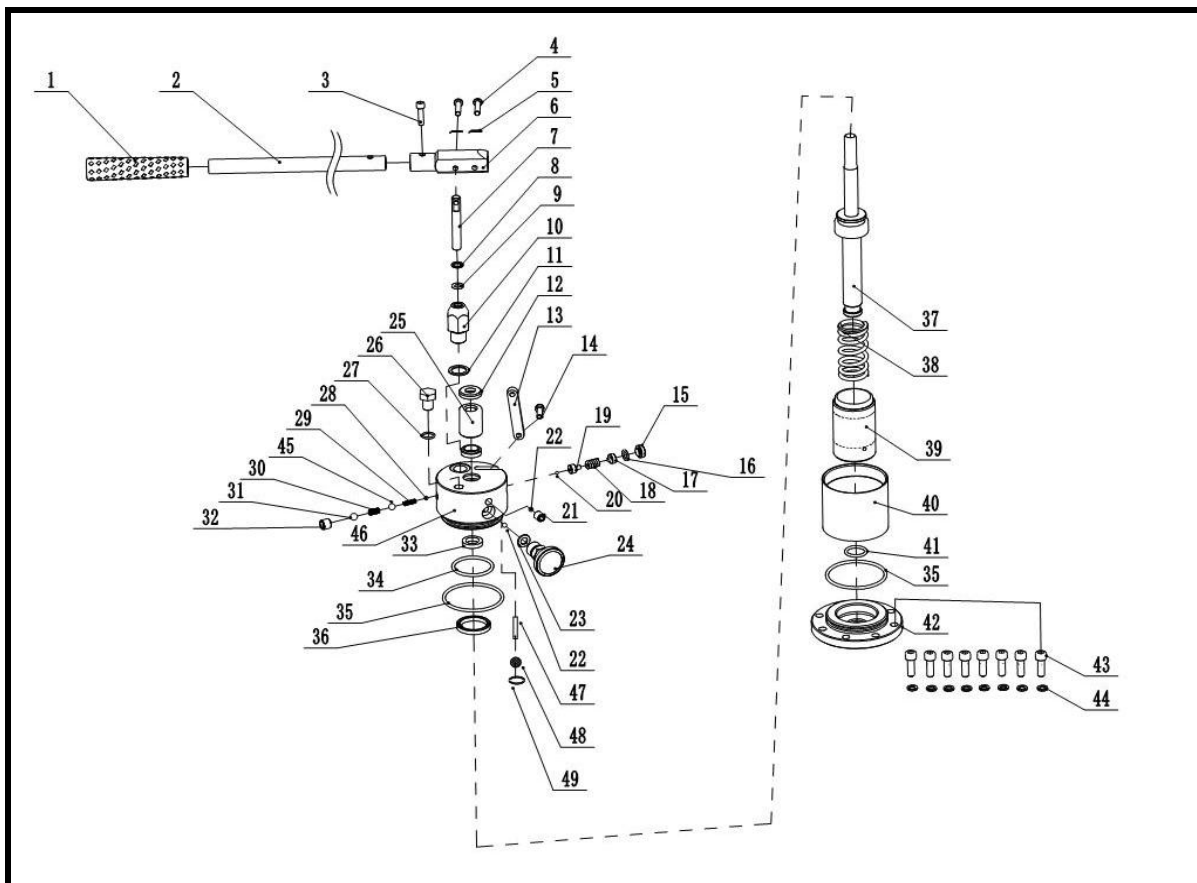

No.	Item Code	Specification	No./ Unit	Type	Note
1	15062	plastic sleeve	1	* std. parts	
2	19015	pump lever	1	** machined	
3	15042	hex screw	1	* std. parts	
4	15057	hinge pin	2	* std. parts	
5	15060	split pin	2	* std. parts	
6	18004	lever seat	1	** machined	
7-11	98017	hex cylinder	1	** asselbly	
7	19028	piston rod	1	** machined	not recommend to order separately order #98017 instead
8	16026	PTFE gasket	1	*** sealing	
9	16027	O-ring	1	*** sealing	
10	19024	hex cylinder liner	1	** machined	
11	15117	brass washer	1	* std. parts	
12	19026	lock nut	1	** machined	
13	19031	slide block	1	** machined	
14	15042	hex screw	1	* std. parts	
15	19005	releave valve plug	1	** machined	
16	16002	O-ring	1	*** sealing	
17	19006	adjust screw	1	** machined	
18	19016	adjust spring	1	** spring	
19	19018	ball seat	1	** machined	

RG-1A Electric & Hydraulic Roll Grooving Machine

Explosive view & part list

Hydraulic Pump

20	16017	steel ball	1	*** sealing	
21	15065	plug	1	* std. parts	
22	16018	steel ball	1	*** sealing	
23	15064	brass washer	1	* std. parts	
24	98016	relieve valve	1	** asselbly	
25	19027	stop knob	1	** machined	
26	19039	grease nuzzle	1	** machined	
27	16001	O-ring	1	*** sealing	
28	16019	steel ball	1	*** sealing	
29	19038	spring of filling valve	1	** spring	
30	19037	spring of outlet valve	1	** spring	
31	16015	steel ball	1	*** sealing	
32	15066	plug	1	* std. parts	
33	16028	gasket	1	*** sealing	
34	16029	O-ring	1	*** sealing	
35	16030	O-ring	2	*** sealing	
36	16031	gasket	1	*** sealing	
37	19029	piston	1	** machined	
38	19035	spring	1	** spring	
39	19034	cylinder housing	1	** machined	
40	19032	oil cilinder	1	** machined	
41	16032	O-ring	1	*** sealing	
42	19036	pump seat	1	** machined	
43	15111	hex screw	8	* std. parts	
44	15074	spring washer	8	* std. parts	
45	16016	steel ball	1	*** sealing	
46	19009	pump head assembly	1	** machined	
47	19008	oil suction tubing	1	*** sealing	
48	15067	copper filter	1	* std. parts	
49	16004	O-ring	1	*** sealing	

Spare part recommendation:

- Type * No need for inventory, can be found at local market or covered in warranty;
- Type ** Small local inventory recommended for missing/ physical damage;
- Type *** Local inventory recommended for replacing;

RG-1A Electric & Hydraulic Roll Grooving Machine

Explosive view & part list

Pipe Stand

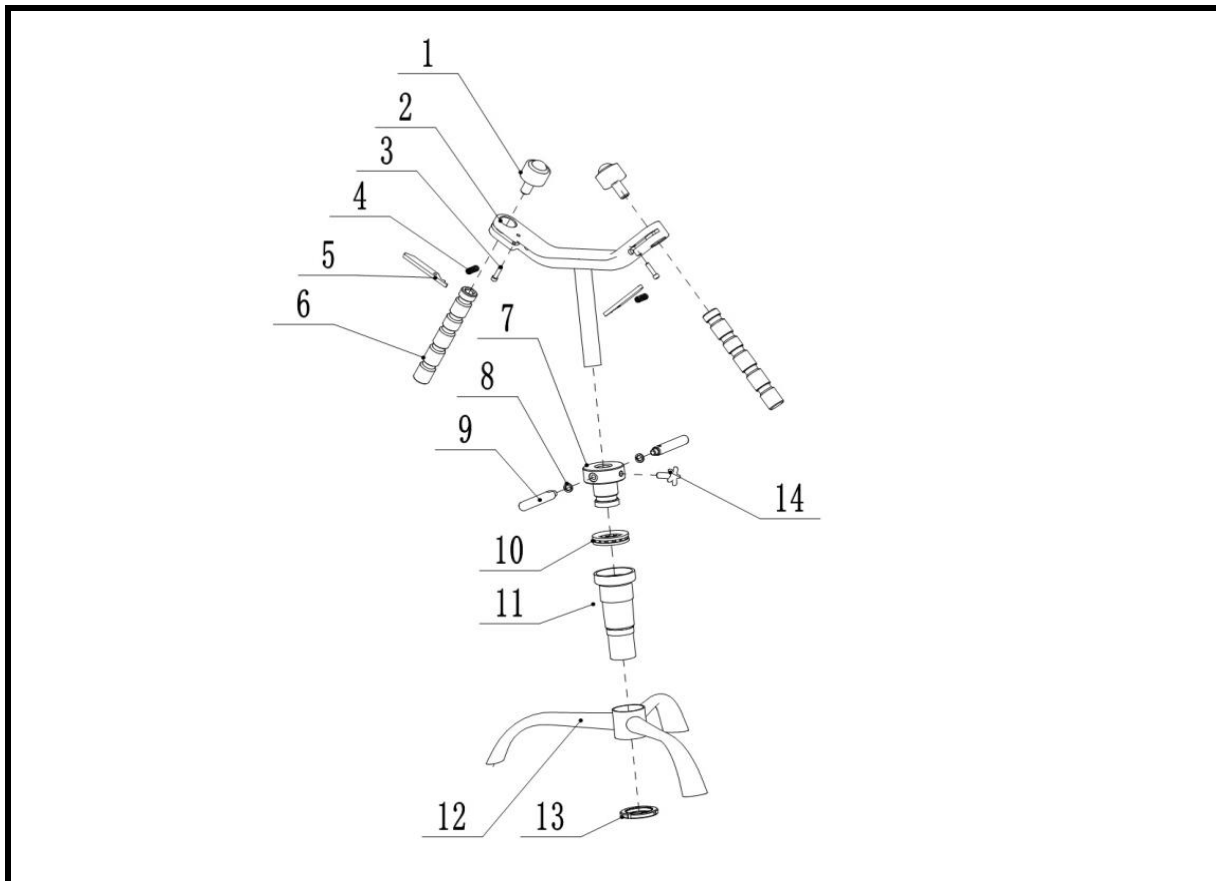

No.	Item Code	Specification	No./ Unit	Type	Note
1	15153	ball seat	2	* std. parts	
2	18010	v-bracket	1	** machined	
3	15042	hex screw	2	* std. parts	
4	15154	spring	2	** spring	
5	13028	locating block	2	** machined	
6	11123	ball joint axle	2	** machined	
7	11048	adjusting socket	1	** machined	
8	15078	spring washer	2	* std. parts	
9	11077	handle	2	** machined	
10	15155	ball bearing	1	*** bearing	
11	21024	axle sleeve	1	** machined	
12	15156	five feet stand	1	** machined	
13	15107	round nut	1	* std. parts	
14	15157	set wheel	1	* std. parts	

Spare part recommendation:

Type * No need for inventory, can be found at local market or covered in warranty;

Type ** Small local inventory recommended for missing/ physical damage;

Type *** Local inventory recommended for replacing;

RG-1A Electric & Hydraulic Roll Grooving Machine

Explosive view & part list

Pipe Stabilizer

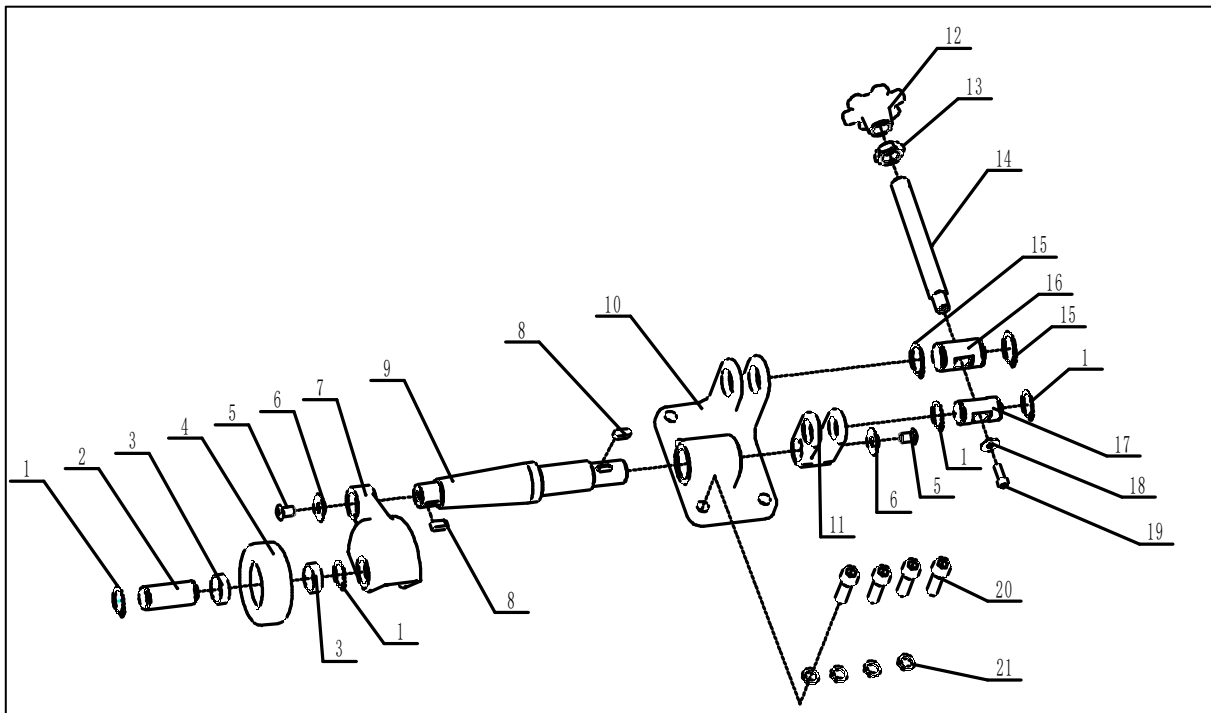

No.	Item Code	Specification	No./ Unit	Type	Note
1	15096	elastic collar	4	* std. parts	
2	11061	roller axle	1	** machined	
3	12015	axle sleeve	2	** machined	
4	15097	nylon roller	1	* std. parts	
5	15009	hex screw	2	* std. parts	
6	15098	washer	2	* std. parts	
7	10010	roller housing	1	* casting	
8	15099	flat key	2	* std. parts	
9	11076	main shaft	1	** machined	
10	10011	roller seat	1	* casting	
11	10012	rotation arm	1	* casting	
12	15100	hand wheel	1	* std. parts	
13	15101	hex nut	1	* std. parts	
14	11063	thread rod	1	** machined	
15	15102	elastic collar	2	* std. parts	
16	11064	feed axle	1	** machined	
17	11065	rotation axle	1	** machined	
18	15103	washer	1	* std. parts	
19	15104	hex screw	1	* std. parts	
20	15076	hex screw	4	* std. parts	
21	15078	spring washer	4	* std. parts	

Spare part recommendation:

- Type * No need for inventory, can be found at local market or covered in warranty;
 Type ** Small local inventory recommended for missing/ physical damage;
 Type *** Local inventory recommended for replacing;