

WARNING:

Read this Operator's Manual carefully before using this tool. Failure to understand and follow the contents of this manual may result in electrical shock, fire and/or serious personal injury.

GENERAL SAFETY REQUIREMENTS

Work Area Safety

- Keep work zone **clean and lighted**. Cluttered or dark areas may bring accidents.
- **Do not operate cutting in explosive atmospheres**, such as in the presence of flammable liquids, gases, or dust. Electric motor may create sparks which may ignite the dust or fumes.
- **Keep children and irrelevant person away** while operating a pipe cutting machine.
- Keep floors dry and **free of slippery materials** such as oil.

Personal Safety

- **Stay alert** while operating a cutting machine. Do not use a machine while fatigued or under the influence of drugs, alcohol, or medication. Inattention when using cutting machine may result in serious personal injury.
- Use **personal protective equipment**. Always wear eye glasses.
- **Remove any rulers or wrench before using cutting machine**. Tools left attached to a rotating part of the machine may result in personal injury.
- **Dress properly**. Do not wear loose clothing or jewelry. Keep hair, clothing, and gloves away from moving parts.

Electrical Safety

- **Power tool plugs must match the outlet. Never modify the plug in any way**. Do not use any adapter plugs with grounded (earthed) power tools. Unmodified plugs and matching outlets will reduce risk of electric shock.
- **Avoid body contact with grounded or earthed surfaces, such as pipes or radiators**. There is an increased risk of electric shock if personal body is grounded.
- **Do not expose power tools to rain or wet conditions**. Water entering a power tool will cause electric shock.
- **Do not abuse the cord**. Never use the cord for carrying, pulling or unplugging the power tool. Keep cord away from heat, oil, sharp edges or moving parts. Damage or entangled cords increase the risk of electric shock.
- **When operating a power tool outdoors, use an extension cord suitable for outdoor use**.
- **If operating a power tool in a damp location, use a Ground Fault Circuit Interrupter (GFCI) protected supply**.

Power Tool Use and Care

- **Always use the correct power tool for each application.** The correct power tool will do the job right and safer at the rate for which it was designed.
- **Do not use the power tool if the switch does not turn it ON and OFF.** Any power tool that cannot be controlled with the switch is dangerous and must be repaired.
- **Disconnect the plug from the power source before making any adjustments, changing accessories or storing power tools.**
- **Store idle tools away from children** and do not allow persons unfamiliar with the tool or these instructions to use the cutting machine. Cutting machine is dangerous in the hands of untrained users.
- **Maintain tools.** Check for misalignment or binding of moving parts, breakage of parts and any other condition that may affect the tool's operation. If damaged, have the tool repaired before use.
- Use only accessories that are recommended for CHM series Electronic pipe cutting machine.
- **Keep handles dry and clean;** free from oil and grease.

Service

- **Have the cutting machine serviced only by a qualified repair person using identical replacement parts.**

Pipe Cutting Safety

- **Cutter is made to cut 3/4" through 20" carbon steel or stainless steel pipes.**
Follow instructions in operator's manual on proper use. Other uses may increase risk of injury.
- **Keep hands away from cutter blade.** Reduces risk of being cut.
- **Keep guards in place.** Removal of guards increases the risk of injury.
- **Properly support the pipe to prevent the tipping of the pipe and equipment.**
- **Set-up cutter and pipe supports on a flat, leveled surface. Be sure the cutter is stable and will not tip over. Do not use on a bench or any elevated surface.** Improper set-up increases the risk of injury.
- **Always wear appropriate personal protective equipment** such as protection glasses, tight fitting leather gloves, steel toed footwear, and a hardhat.
- **Do not wear loose clothing. Keep sleeves and jackets buttoned. Do not reach across the machine or pipe.** Clothing can be caught by the pipe resulting in entanglement and serious injury.
- **Keep all personnel clear of rotating pipe. Use barricades if necessary.** Prevents entanglement in the pipe.
- **Only use roll cutting machine to cut pipes or conduits of recommended sizes and types according to this instruction.** Improper use or modification of the cutting machine for other applications may increase the risk of injury.
- **Do not use with dull, bent or damaged cutter wheels.** Less likely to bind and lose control. **Keep hands and feet clear of the pipe in the event it falls after being cut.** High pressure exerted by the cutter may cause the cut section to fly with considerable force. It may result in serious injury.



DESCRIPTION, SPECIFICATIONS and STANDARD EQUIPMENT DESCRIPTION

CHM series Electric Pipe Cutting Machine is a motor driven pipe cutting machine designed with an advanced hydraulic feeding system. It cuts $\frac{3}{4}$ " (19mm) to 20" (530mm) schedule 10/40 carbon steel & stainless steel pipes, galvanized pipe, rigid conduit, etc. at the job site or in the shop. With a displacement cutter that provides square cuts. The operator controls the feeding rate by pumping the hydraulic hand pump throughout the operation. A square cut with minimal burr on either 6m/21feet or nipple lengths of pipe is achieved quickly without abrasive dust, sparks, or open flame.

The CHM series Electric Pipe Cutting Machine is designed for **heavy volume work** on job site and for workshop in-house fabrication.



CHM-1X
2" ~ 8"



CHM-2X
2" ~ 12"



CHM-3X
 $\frac{1}{2}$ " ~ 8"



CHM-4X
8" ~ 20"

User Manual

Specifications

Capacity

CHM-1X	2" – 8" Schedule 10 to 40 max. 8mm (5/16")	CHM-2X	2" – 12" Schedule 10,20 and 40 max. 10mm (3/8")
CHM-3X	1/2" –4" Schedule 10/40 & 5" –8" SCH10/20 max. 6mm (1/4")	CHM-4X	8" – 20" Schedule 10,20 and 40 max. 13mm (1/2")

Pipe material.....Carbon steel (incl. plastic lined) / SS /Copper / Aluminum / HDPE pipes

Cutting speed (w/ 1400rpm gear motor)(CHM-1X / -2X /-3X): 23 r.p.m.

(CHM-4X): 20 r.p.m.

Operation Methods.....(CHM-1X/-3X) Single phase motor 700W / 110~240V / 50~60Hz , or
Three phase motor 550W / 220~440V / 50~60Hz (optional)

(CHM-2X / CHM-4X) Single phase motor 1100W / 110~240V / 50~60Hz , or
Three phase motor 750W / 220~440V / 50~60Hz (optional)

Actuation.....Hydraulic Hand Pump

Weight approx. (CHM-1X) 80 kgs/ 176 lbs
(CHM-2X) 120 kgs/ 224 lbs
(CHM-3X) 65 kgs/ 143 lbs
(CHM-4X) 200 kgs/373 lbs

Packing size L×W×H(CHM-1X) 670mm×470mm×750mm / 26.4”×18.7”×25.8”

(CHM-2X) 670mm×600mm×1000mm / 26.4”×23.6”×39.4”

(CHM-3X) 520mm×420mm×640mm / 20.5”×16.5”×25.2”

(CHM-4X) 920mm×800mm×1100mm / 36.2”×31.5”×43.3”

CUTTING PROCESS

Work Area & Machine Set-up

1. Make sure the work area follows:
 - Adequate lighting
 - No flammable liquids, vapors or dust that may ignite.
 - Grounded electrical outlet
 - Clear path to the electrical outlet without any oil, sharp edges or moving parts which may damage the electric cord.
 - Dry place for machine and operator. Do not use the machine when standing in water.
 - Level ground
 - Clean up the work area prior to setup any equipment.
2. Set-up guards or barricades to create a minimum of 1.0meter / 3.3 feet of clearance around the Pipe Cutter and workpiece. This “safety zone” prevents others from accidentally contacting the tool or workpiece and either causing the equipment to tip or becoming entangled in the rotating pipe.
3. Plug the Power Drive into the electrical outlet making sure to position the power cord along the clear path selected earlier. If the power cord does not reach the outlet, use an extension cord in good condition. Be sure power cord is clear of the cutter wheel.
4. Check the Power Drive to insure it is operating properly.
 - Depress the switch and make sure it controls the stopping of the Power Drive by releasing the switch.
 - Depress and hold the switch. Inspect the moving parts for misalignment, binding, odd noises or any other unusual conditions that may affect the safe and normal operation of the tool. If such conditions are present, have the power drive serviced.
 - Depress switch in the opposite direction. Check that the power drive rotates in an opposite direction.

Using Pipe Supports

Caution

Pipe supports must be used to prevent cutter wheel damage. Failure to properly support the pipe will result in shortened wheel life.

1. As shown in illustration, the cutter and pipe supports must be positioned so that the pipe sections have a tendency to fall away from the cutter blade as the pipe is cut. If the cutter wheel is pinched by the pipe, it will damage the cutter wheel.

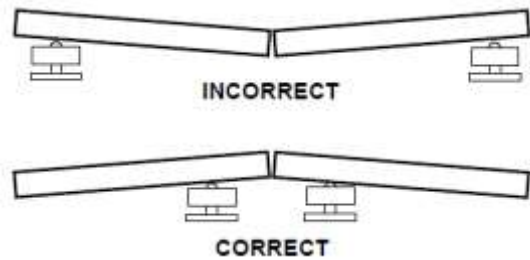

2. Normally, pipe support should be placed about 400mm / 1.3feet from the pipe end. Refer to illustration below.

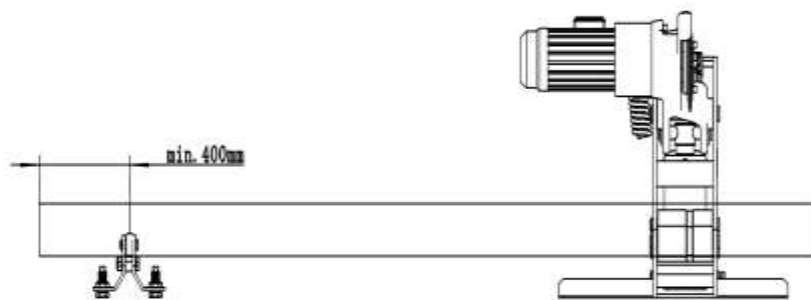

3. Adjust the handle on the pipe support to even the pipe. Make sure pipe will touch all rollers on the cutting machine balanced.

Operating Instructions

Keep fingers and hands away from cutter wheel. Do not reach across cutter or pipe. Keep hands and feet clear of pipe.

Be sure cutter is on a flat, level surface and the pipe is properly supported by pipe stands.

1. Be sure pipe is properly supported by pipe supports and will not pinch and damage the cutter wheel.
2. By using CHM-2X, for cutting pipes 2"~8", place pipe on the rollers on in the wheel carrier. For cutting pipes in 10"~12", full open the wheel carrier and place pipe on the rollers on the machine housing. Refer to Figure A.

Likewise, open the wheel carrier when cut pipes in 2" / DN50 or greater with GHM-3X.

Likewise, open the wheel carrier when cut pipes in 16" / DN400 or greater with GHM-4X.

3. Mark the pipe at the desired length for cutting (use chalk or pipe marker).

4. Position pipe at marked point to the cutter wheel. Insure pipe is resting squarely on cutter frame rollers. Use pump to square pipe to the cutter wheel to avoid miss-tracking.

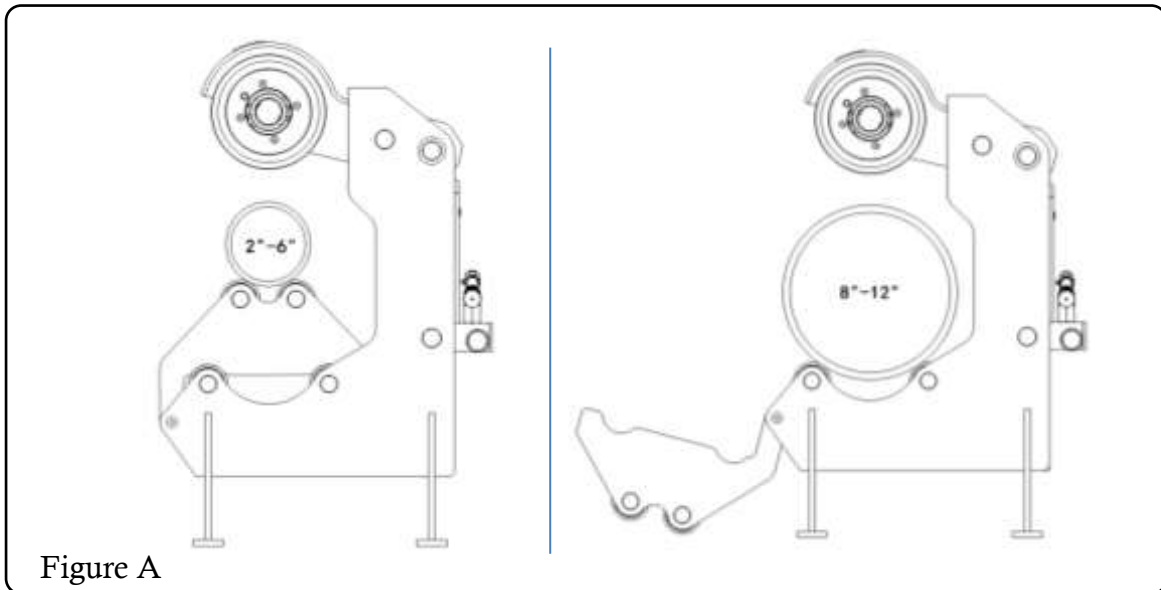

5. Assure the correct operating position behind the pipe. Press hand pump. Continue pumping pump to advance pivot arm and cutter wheel to the pipe.
6. After wheel comes in contact with pipe, pump an additional 1 or 2 strokes, start driven motor. The pipe will start rotating once cutter wheel engages the pipe.
7. Pump 1 stroke again. This will “seat” the cutter wheel. Allow the pipe to rotate one or two revolutions without pumping.

WARNING! Do not force cutter or pump more than 1 stroke per turn. It may cause personal injury or wheel damage.

8. Continue this process until pipe is cleanly cut through.

MAINTENANCE INSTRUCTIONS

WARNING! Make sure Power drive is unplugged from power source before performing maintenance or making adjustment.

1. Ensure cutter frame rollers and pipe support rollers are free to rotate under the pipe. Clean debris, pipe scale, and dirt from rollers.
2. Ensure the four screws and lock washers are tight in the cutter wheel assembly. Periodically check.
3. Fill the hydraulic hand pump if necessary.
4. Change a new cutting blade when the blade is dull.

Machine Storage

- Store the tool in a locked area that is out of reach of children and people unfamiliar with pipe cutting machines. This machine can cause serious injury in the hands of untrained users.
- Motor-driven equipment must be kept indoors or well covered in rainy weather.

Accessories

The following products have been designed to function with the CHM series Electric Pipe Cutting Machines. Other accessories suitable for use with other tools may be hazardous when used on the CHM series Cutting Machines. To reduce the risk of serious injury, only use accessories specifically designed and recommended for use with the CHM series Cutting machines, such as those listed below.

Standard Equipment & Item Code of

GHM series Electric Pipe Cutting Machines

CHM-1X for 2"~8"		CHM-2X for 2"~12"	
■ #99014	CHM-1X Pipe cutting machine	■ #99026	CHM-2X Pipe cutting machine
■ #98051	Single phase motor -- 700W / 110-240V / 50~60Hz	■ #98052	Single phase motor -- 1100W / 110-240V / 50~60H
■ #98045	(optional) Three phase motor -- 550W / 110-240V / 50~60Hz	■ #98046	(optional) Three phase motor -- 750W / 110-240V / 50~60Hz
■ #12019	C.S. Cutting blade	■ #12019	C.S. Cutting blade
■ #98057	Hydraulic hand pump	■ #98058	Hydraulic hand pump
■ #98030	Pipe support 2"~8"	■ #98041	Pipe support 2"~12"
CHM-3X for 1/2"~8"		CHM-4X for 8"~20"	
■ #99064	CHM-3X Pipe cutting machine	■ #99048	CHM-4X Pipe cutting machine
■ #98051	Single phase motor -- 700W / 110-240V / 50~60Hz	■ #98052	Single phase motor -- 1100W / 110-240V / 50~60H
■ #98045	(optional) Three phase motor -- 550W / 110-240V / 50~60Hz	■ #98046	(optional) Three phase motor -- 750W / 110-240V / 50~60Hz
■ #12019	C.S. Cutting blade	■ #12019	C.S. Cutting blade
■ #98092	Hydraulic hand pump	■ #98058	Hydraulic hand pump
■ #98161	Pipe support 1/2"~8"	■ #98102	Pipe support 8"~20"

*All Cut machines are suitable to use #12058 S.S. material Cutting blade.

Troubleshooting

Problem	Cause	Correction
Cutter blade does not track	Pipe is not properly supported.	Short lengths of pipe must rest squarely on cutter frame rollers. Long lengths must be supported with stands so
	Cutter is not firmly clamped to pipe.	Insure cutter squares itself to the pipe by pumping several times before starting power drive
	Cutter blade has not been preloaded 1 stroke before	Pump 1 strokes on hand pump after cutter blade contacts the pipe before starting motor.
Pipe does not rotate	Cutter blade is not properly assembled	Insure cutter blade is free to rotate in either direction in hub assembly
	Pipe is out of round	Insure that pipe is free of flat areas or has not been crushed
Motor does not start	Interruption of power supply	Examine supply.
	Fuse blown	Install fuse.
Hand pump does not advance ram	Low hydraulic fluid	Insure fluid level is at full capacity
	Air in hydraulic system	Bleed system
Abnormal heating of motor	Overload because of continuous operation	Let power drive cool after continuous use
	Insufficient cooling air	Clean the air-vent opening of the motor

Service and Repair

The “Maintenance Instructions” will take care of most of the service needs of this machine. Any problems not addressed by this section should only be handled by an authorized service technician. Tool should be taken to a Independent Authorized Service Center or returned to the factory. When servicing this machine, only identical replacement parts should be used. Use of other parts may create a risk of serious injury.

Chart A – Pipe O.D. & Wall thickness parameters

Nom. Pipe Size	Pipe O.D.			C.S. pipe wall thickness			S.S. pipe wall thickness	
	Basic	Tolerance		SCH10	SCH20	SCH40	10S	40S
		in. mm	+in. + mm	-in. -mm	in. mm	in. mm	in. mm	in. mm
2" 50	2.375 60.3	0.024 0.61	0.024 0.61	0.109 2.77	0.109 2.77	0.154 3.91	0.109 2.77	0.154 3.91
2½" 65	2.875 73.0	0.029 0.74	0.029 0.74	0.120 3.05	0.120 3.05	0.203 5.16	0.120 3.05	0.203 5.16
3OD 65	3.000 76.1	0.030 0.76	0.030 0.76	0.120 3.05	0.120 3.05	0.203 5.16	0.120 3.05	0.203 5.16
3" 80	3.500 88.9	0.035 0.89	0.031 0.79	0.120 3.05	0.120 3.05	0.216 5.49	0.120 3.05	0.216 5.49
3½" 90	4.000 101.6	0.040 1.02	0.031 0.79	0.120 3.05	0.120 3.05	0.226 5.74	0.120 3.05	0.226 5.74
4" 100	4.500 114.3	0.045 1.14	0.031 0.79	0.120 3.05	0.120 3.05	0.237 6.02	0.120 3.05	0.237 6.02
5½OD 125	5.500 139.7	0.056 1.42	0.031 0.79	0.134 3.40	0.134 3.40	0.258 6.55	0.134 3.40	0.258 6.55
5" 125	5.563 141.3	0.056 1.42	0.031 0.79	0.134 3.40	0.134 3.40	0.258 6.55	0.134 3.40	0.258 6.55
6½OD 150	6.500 165.1	0.063 1.60	0.031 0.79	0.134 3.40	0.134 3.40	0.280 7.11	0.134 3.40	0.280 7.11
6" 150	6.625 168.3	0.063 1.60	0.031 0.79	0.134 3.40	0.134 3.40	0.280 7.11	0.134 3.40	0.280 7.11
8OD 200	8.000 203.2	0.063 1.60	0.031 0.79	0.148 3.76	0.250 6.35	0.322 8.18	0.148 3.76	0.322 8.18
8" 200	8.625 219.1	0.063 1.60	0.031 0.79	0.148 3.76	0.250 6.35	0.322 8.18	0.148 3.76	0.322 8.18
10" 250	10.750 273	0.063 1.60	0.031 0.79	0.165 4.19	0.250 6.35	0.365 9.27	0.165 4.19	0.365 9.27
12" 300	12.750 323.9	0.063 1.60	0.031 0.79	0.180 4.57	0.250 6.35	0.406 10.31	0.18 4.57	0.375 9.53