



Technical description of non isolated safety protection

SAFETY MATS SENSOR EDT14 series



More protection / Less worry

The use of EDT14 non-isolated safety protection device is related to personal safety. Please read the instruction manual carefully before use! The instruction manual is an important document to guide users to correctly install and use non-isolated safety protection devices. Agents, distributors, and machine tool manufacturers must deliver the instruction manual to users along with the safety protection device!

catalogue

1. Product introduction of non isolated safety protection system

2. Unit matching of non isolated safety protection system

3. Technical description of non isolated safety protection device components

4. Product selection and technical standards

- 1) Product introduction
- 2) System technical standards
- 3) General product specifications
- 4) Special shaped customization

5. Features of safety mat products

- 1) Effective size and edge non sensing area
- 2) Safety mat installation accessories

6. System installation

- 1) Installation of safety mat

7. Wiring instructions

- 1) Relay coil wiring diagram
- 2) Wiring diagram of safety relay

8. Design essentials of non isolated safety protection system

- 1) Design essentials of non isolated safety protection
- 2) Configuration of non isolated safety protection system

9. matters needing attention

- 3) Storage and installation precautions
- 4) Precautions for use

Note: please read the product information in this technical description carefully. It contains important contents related to product operation, safety and maintenance. Please keep this technical description for future reference.

1. Product introduction of non isolated safety protection system

Nonisolated safety protection system is used to detect people standing or stepping on in a specific area. In industrial application, it is a safety protection device of automatic equipment, which meets the highest safety protection requirements. The non isolated safety protection system can detect whether there are people in the laid area within a specific time to prevent personal injury and danger caused by the movement of the machine.

Provide necessary safety protection for personnel working in hazardous areas.

Non-isolated safety protection systems offer the following advantages:

- 1) Inductive safety mats have high trigger sensitivity, providing safety protection for personnel weighing over 30 kg.
- 2) The installation area of the safety mats is flexible; different sizes or shapes of safety mats can be provided according to user needs.
- 3) Different types of safety mats can be selected based on different working conditions and usage environments. The correct use of non-isolated safety protection systems depends on the following factors:

Determining the working conditions of the installation area.

Correctly selecting the size of the installation area.

Correct installation method.

2. Unit matching of non isolated safety protection system

A non-isolated safety protection system consists of safety pads, protected areas, and matching safety relays. A protected area can be a single safety pad or multiple safety pad areas connected in series. A maximum of 5 to 6 safety pads can be connected in series in one area. The total area of the protected area must not exceed 3 to 4 square meters.

3. Technical description of non isolated safety protection device components

This product is normally open without resistance. It needs resistance. Please contact our factor before customization.

There are four core wires (black, white, red and yellow), in which black and white are a group of normally open and closed quantities, which will be connected under the action of external force (people step on it), so as to transmit signals to the controller or relay to control the machine. Red and yellow are also a group of normally open and closed values (white and yellow can also be used as a group, black and red as a group). The white and red lines are connected without external force (a group of normally closed points), and so are the black and yellow lines (the normally closed point is only for detection, can not be used as normally closed mat, and has no function of normally closed mat. Using this function needs to cooperate with ETer-A safety relay).

This product is a pressure-sensitive touch switch and requires a controller or relay for use.

When fixing the frame, please ensure the grounding terminal is secure and fix it at all four corners (if applicable).

This product is not suitable for underwater environments. Please contact us in advance if you require underwater use.

4. Product selection and technical standards

1) Product introduction

Sensing safety mat	EDT14
Adaptive detection range	Detect the presence of operators and items
Recommended occasions	It is applicable to the safety protection of mixed areas of people and small vehicles
Service environment requirements	It is suitable for indoor and outdoor use, and the ambient temperature range is -10°C ~ +60°C
Safety mat thickness	14 millimeter
Surface protective material	NBR rubber
Surface pattern and color	Coppercoin, pattern anti-skid surface (black, yellow, red)
Edge banding form	Aluminum edge sealing
Applicable industry	Light and heavy industrial occasions such as paper indust, electronic indust, automobile welding production line, forging production line, general industrial application and automatic palletizer
Ordering instructions	Provide the size of safety mat and the size or pattern of safety protection area

2) System technical standards

size	It can be specially made according to requirements, with length of 200mm-1000mm and width of 200mm-2000mm
Underpressure	Dynamic 500kg, solid 700kg
Surface material	Rubber(red / yellow / Black optional)
Control level	Shared with controller to reach level 3
Degree of protection	IP65
ambient temperature	-10 °C to 60 °C
thickness	14mm
Trigger force	Adult 30kg
Cable length	3M and 5m optional
response time	Less than 30ms
weight	About 30kg / sq.m
Chemical resistance	Less than 30ms
Material ability	commonly
service life	100 Ten thousand times
waterproof	commonly
Anti mineral acid	commonly
Anti organic acid	commonly
Anti alcohol	commonly
Anti ethanol	commonly
Corrosion protection	commonly
Anti petroleum solvent	commonly
Anti bio oil solvent	commonly
type of output	No (normally open)
Maximum voltage	DC 24V

3) General product specifications

Product model	width	length	type of output	Entry cable
EDT14-250*500	250mm	500mm	NO	4-core
EDT14-500*500	500mm	500mm	NO	4-core
EDT14-500*1000	500mm	1000mm	NO	4-core
EDT14-750*1000	750mm	1000mm	NO	4-core
EDT14-1000*1000	1000mm	1000mm	NO	4-core
EDT14-1100*1800	1100mm	1800mm	NO	4-core

4) Special shaped customization

Users can customize the special-shaped design according to the drawings or dimensions, and consult our factory for details.

5. Safety mat product features

1) Effective size and edge non sensing area

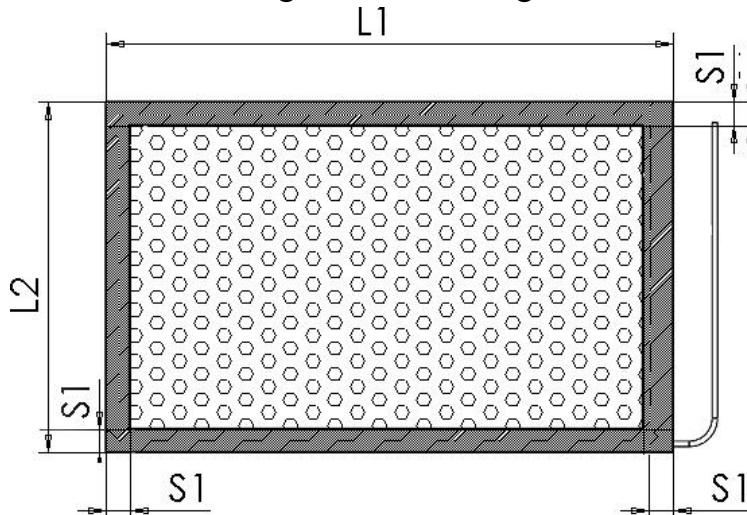

The effective area of a standard safety pad is $L1 \times L2 \leq 1.5\text{m}^2$. For protection areas exceeding 1.5m^2 , it is recommended to use multiple safety pads joined together.

The cable is led out from one corner by default, with a standard lead length of 3 meters.

The edge of the safety pad packaging is a non-inductive area and does not have sensing functionality. $S1 \approx 45\text{mm}$

Note: When multiple safety pads are joined together, only the non-lead edge can be joined with the adjacent safety pad.

2) Safety mat installation accessories

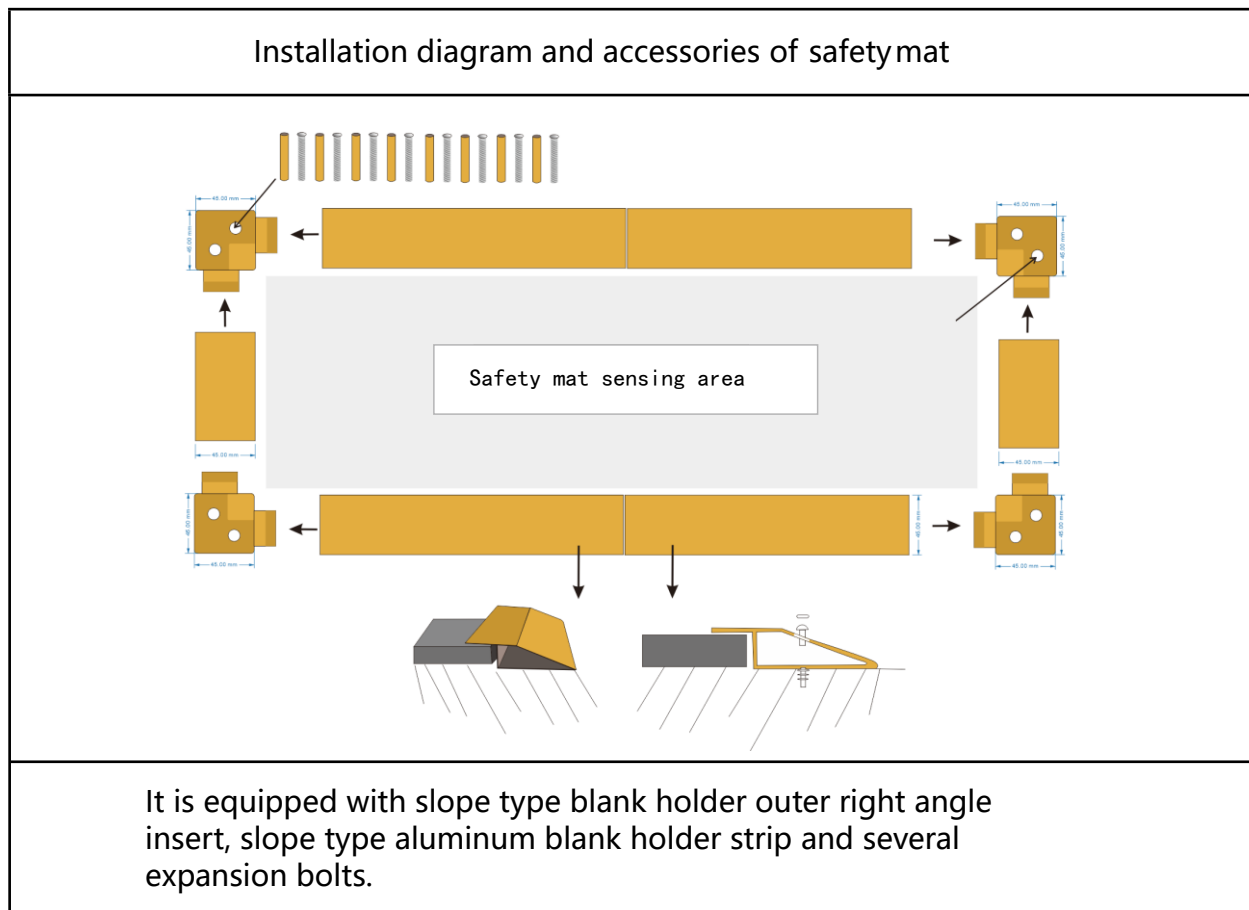

Note: non standard custom installation accessories are not listed in this table.

6. System installation

Installation of safety mat

Please install the safety pads following these steps:

1) Unpacking: Remove the safety pads and installation accessories. Check that the contents of the packaging match the provided list and that the safety pads are intact.

2) Installation Site Preparation: The installation site should be flat and free of holes larger than 20mm in diameter or uneven surfaces. Any defects in the ground will cause the safety pads to lose their safety function.

3) Remove dust particles from the installation surface and ensure the surface is dry.

a. Drill holes in the mounting base according to the mounting hole positions on the aluminum baffle. Clean the aluminum baffle, base, and drilled holes (using a vacuum cleaner). Otherwise, dust generated during drilling will cause unevenness under the safety pads and aluminum sealing strips.

b. Lay the safety pads for each area in series and connect the wiring. Connect the signal wires to the safety relays in the control cabinet.

4) Connect the safety pads and safety relays to the machine's control system according to the system configuration.

Note: The cable is for signal output only. Do not drag the cable for positioning when installing the safety pads.

5) Depending on the working conditions and the type of safety pad, different types of safety pads require different installation accessories.

7. Wiring instructions

Note: This product must not be in direct contact with the powersupply. It needs the auxiliary use of relay or controller.

The maximum voltage is DC 24V

Four wire mat circuit diagram

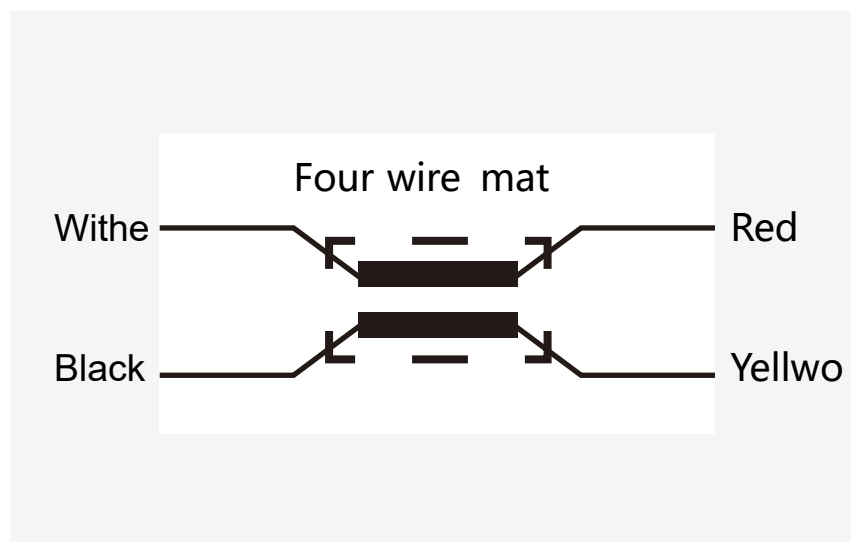

1) Relay coil wiring diagram- this diagram is not a safe circuit and should be used with caution

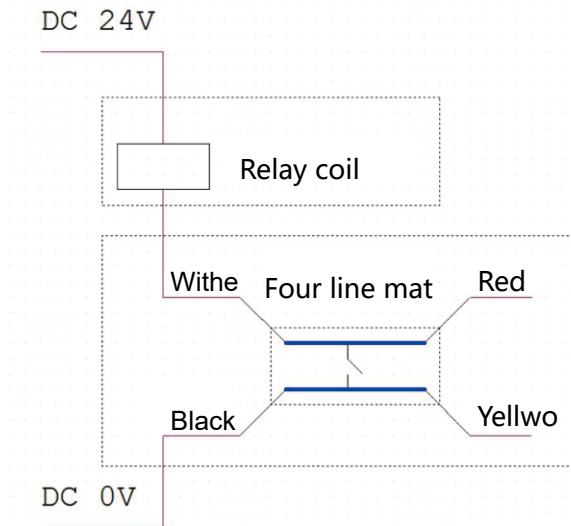

This figure is a non safety circuit, use with caution!

2) Wiring diagram of safety relay
Safety relay model: ETer-A

A1: connect +24V± 10% (20V~26V)
A2: connect 0V

Automatic reset: turn the toggle switch to A
Manual reset: turn the toggle switch to M

Safety relay connection:



Non isolated safety protection of single safety mat

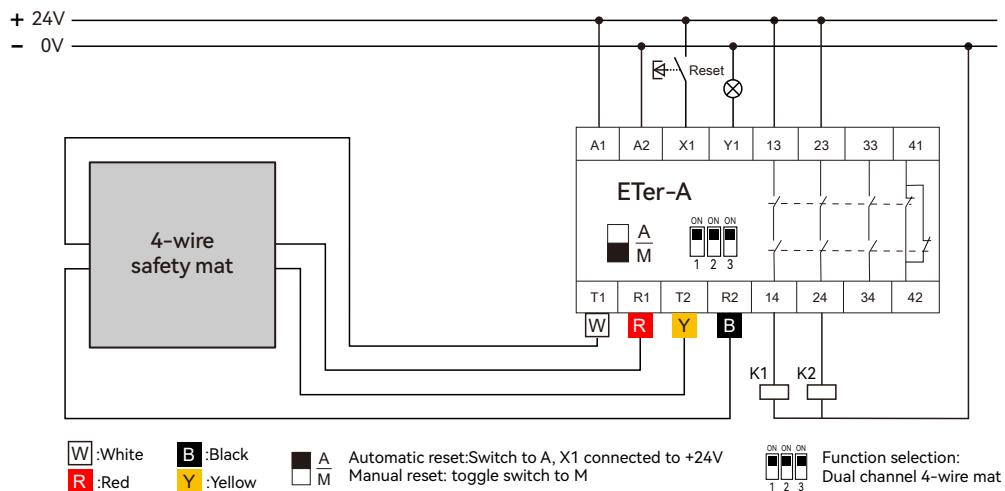

Double channel 4-wire mat safety input manual reset

White and red are a group, connected to T1 or R1
Black and yellow are a group, connected to T2 or R2

Red line and white line: connected to T1 and R1, regardless of order
 Black line and yellow line: connected to T2 and R2, regardless of order
 Or: red line and white line: connect T2 and R2, regardless of order
 Black line and yellow line: connected to T1 and R1, regardless of order

Safety relay system module diagram

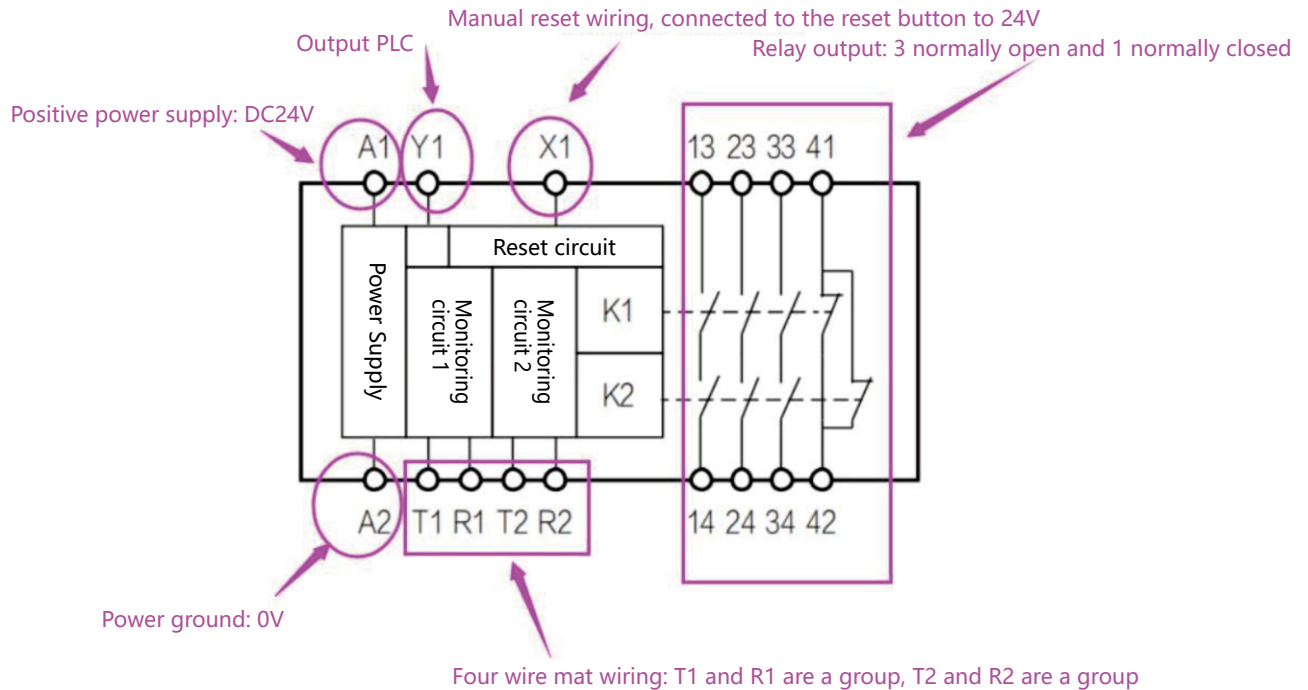

This product has the function of testing: whether the wiring of the four wire touch mat is correct and whether the wiring is falsely connected. If the wiring is wrong or the line is falsely disconnected, the safety relay will actively respond to the safety function.

Function description of safety relay terminal

A1	Power supply positive (24V DC)	A1 and A2 as power supply
A2	Negative pole of power supply (0V)	
T1	Channel 1 signal output	Type I signal source
R1	Channel 1 safety input	Accept type I signal input, with short circuit, open circuit detection and mutual inspection of channel 2
T2	Channel 2 signal output	Type II signal source
R2	Channel 2 safety input	Accept type II signal input, with short circuit, open circuit detection and channel 1 mutual inspection automatic reset: when the input conditions are met, the unit is activated immediately
X1	Reset input (manual reset or automatic reset can be configured)	Manual reset: the input conditions are met, and the reset circuit is then manually closed. After release, the unit is activated
Y1	Transistor signal output	Output status signal indication, which can be input as PLC signal or connected to external indicator
13/14	Normally open instantaneous safety contact	The unit can be externally connected with tner-ts31 unit on the contact to increase the number of contacts
23/24		
33/34		
41/42	Normally closed instantaneous safety contact	It can be used as external signal lamp or control other devices

Technical parameters of safety relay

Power Supply	
Power supply	24V DC
Voltage tolerance	+10%/-20%
power waste	2.9w
output	
Relay safety output	3NO+1NC
Transistor signal output	<500mA 24VDC
Relay contact capacity	
AC-1	6A/250VAC/1500VA
AC-15	4A/240VAC
DC-1	6A/24VDC/150W
DC-13	4A/24VDC
Maximum switching capacity	12A (distributed on all safety output contacts)
contact resistance	<100mΩ
Minimum load	10 mA / 5V
Contact material	AgSnO ₂ +0.2μmAu
General parameters	
Output fuse (external)	5A GL/GG
Release response time	< 30ms (from input to output),
Input component end detection resistance (tentacle / mat)	1KΩ ~ 10KΩ
Electrical life	80000 lbs
class of pollution	two
working temperature	-25 ° C to 85 ° C
Working humidity	35% - 85% (exposed)
Impulse withstand voltage	2.5kV
Degree of protection	External IP30, sub IP20, IP54 pushed forward
Storage temperature	-40 ° C to 105 ° C
Shell material	Flame retardant PA66
Installation mode	Mark and subtract 35mmdin guide / spring clip
size	114.5mm x 100.5mm x 22.5mm
weight	172g
Connection parameters	
Available cross section range of rigid conductor	0.5~2.5mm ²
Available cross section range of flexible conductor	0.5~2.5mm ²
Minimum conductor cross section	AWG 24
Maximum conductor cross section	AWG 12
Strip length	8 mm
Minimum tightening torque	0.5 Nm
Maximum tightening torque,	0.6 Nm
Standard application	
accord with	EN 60947-1:2007/A2:2014
	EN 60947-5-1:2004/A1:2009
	EN ISO 13849-1:2015
	EN 62061:2005+A2:2015
	

8. Design essentials and configuration of non isolated safety protection system

1) Design essentials of nonisolated safety protection system

The non isolated safety protection system requires that when a person or protected object enters the protected area, the system shall immediately send a command to stop the machine in the area. The machine can not start working again until the operator sends a command after the person or protected object confirms to leave the protected area. According to the requirements, the design essentials are:

The principle of full coverage shall be realized in the safety protection area to avoid personal safety accidents due to personnel in the dangerous area.

The safety relay must use manual reset mode, and automatic reset can be used under special circumstances.

The manual reset button must be installed in the non hazardous area to ensure the system reset after personnel leave the hazardous area.

2) Configuration of nonisolated safety protection system

According to the area to be protected, it can be the safety protection area of a single safety mat, or multiple safety mats can be connected in series into a protection area. The following combination schemes can be selected according to the actual installation conditions and requirements:

Non isolated safety protection assembled by multiple safety mats

This combination is generally used in sensing output mode, single area and multi piece safety mat assembly. A maximum of 5 to 6 safety mats for this splicing method. The total area of the protection area shall not be greater than 3 to 4 square meters

Multiple mats are used in series, and each mat has four core wires (black, white, red and yellow)

White and red are one way, connected to T1 and R1

Black and yellow are one way, connected to T2 and R2

perhaps

White and red are one way, connected to T2 and R2

Black and yellow are one way, connected to T1 and R1

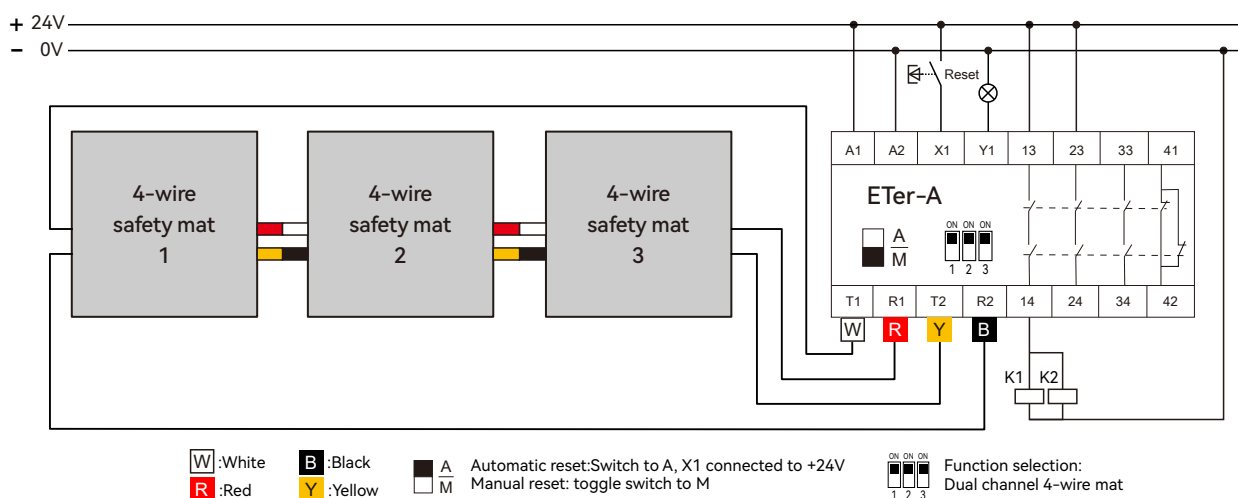

9. matters needing attention

1) Storage and installation precautions

The following actions will cause damage to the safety mat

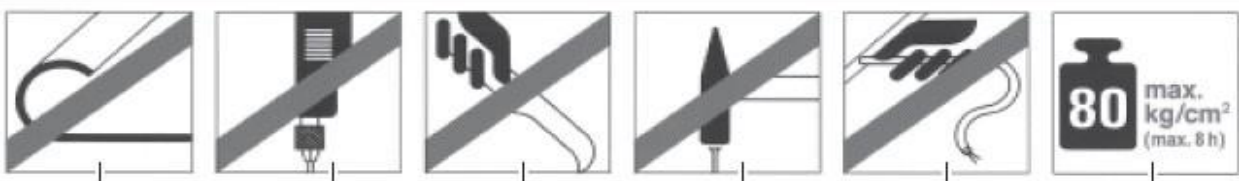

1 2 3 4 5 6

1. The safety mat shall not be curled during use, installation and handling.
- 2 do not drill holes or cut the safety mat.
3. The safety mat cannot be cut
- 4 do not hammer the safety mat or drive nails (screws) on the safety mat.
- 5 do not drag the cable, move or handle the safety mat
6. Do not place the overload on the safety mat for a long time.
The maximum bearing capacity is 80 kg / cm^2 (8 hours)

2) Precautions for use

Be sure to select safety mat and safety relay with safety function certification.

When connected to PLC, it needs to be grounded according to the use requirements. Please regularly check whether the system works normally to ensure its safety function.

Please replace the safety mat beyond its service life in time.

Please replace the safety mat with damaged surface protective layer in time.