

USER MANUAL

WHITE LED LIGHT SOURCE LONG-RANGE COLOR-CODED SENSORS **EGS-C500 series**



Figure can vary

Contents

- Functional Description
- Application Scenarios
- Technical Parameters
- Size Parameters
- Wiring Method
- Usage Guidelines
- Basic Settings



Product characteristics

- White LED light source, wide wavelength, can stably detect color or appearance differences;
- 500mm long-distance detection;
- Good anti-shake performance, with background suppression function;
- EGS-C500 can adjust the spot size;
- Color standard can store 9 colors at the same time;
- Optional with IO-LINK communication.

Product Analysis

Indicator light
 Off: Output OFF
 Orange: Output ON
 Red (flashing): Error

Buttons
 Different methods of adjusting sensitivity and different operation methods

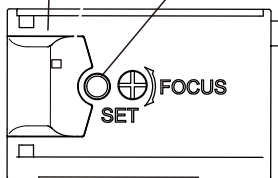

[▼]Buttons

- Change the setting value in less than 1s
- Enter the setting screen in more than 3s

STB: Green light turns on when light is available
 C: Green light turns on when in C/C+I mode
 I: Green light turns on when in C+I/Super I mode

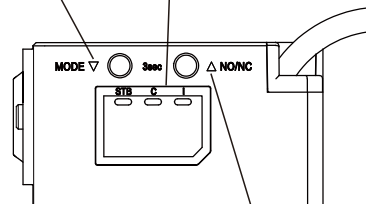

[▲]Buttons

- Less than 1s to change the setting value
- More than 3s to switch between N · O/N.C

Application example

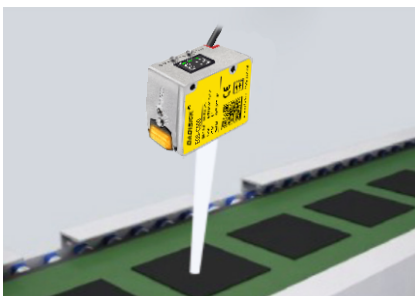

Detect the presence of thin sheets



Detect the presence of glue

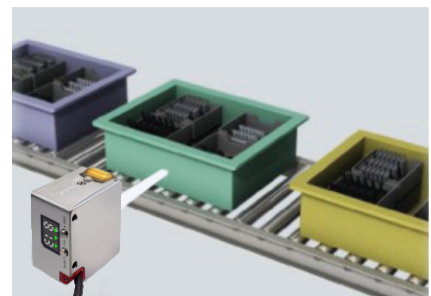

Detect the color of objects on the conveyor belt

Product Parameters

Model	NPN / PNP	EGS-C500N / EGS-C500P
Detection distance	50 to 500 mm	
Minimum light spot diameter	Approx. $\phi 3.5$ mm (at 100 mm) Approx. $\phi 9$ mm (at 250 mm) Approx. $\phi 20$ mm (at 500 mm)	
Response time	200 μ s/1 ms/10 ms/100 ms/500 ms	
Light source	White LED	
Mutual interference reduction	Set different frequencies, up to 2 units	
Power supply	Voltage	10 to 30 VDC with ripple (P-P) 10%, Class 2 or LPS
	Current Consumption	50mA or less at 24V 100mA or less at 12V
Timer	OFF/On delay/Off delay/Single	
I/O	Control output	NPN open collector/PNP open collector switchable 30V or less, 100mA or less, residual voltage 2V or less N.O./N.C. switchable
	External input	Tuning/stop transmission switch type
Protection circuit	Power reverse connection protection, power surge protection, output overcurrent protection, output surge protection	
Ambient light	Incandescent lamp: 10000Lx or less Sunlight: 20000Lx or less	
Ambient temperature	-20 to +50°C (no freezing)	
Relative humidity	35 to 85%RH (no condensation)	
Impact resistance	1,000m/s ² , 6 times in each direction of X, Y, and Z	
Vibration resistance	10 to 55Hz double amplitude 1.5mm, 2 hours in each direction of X, Y, and Z	
Protection level	IP65	
Material	Casing: zinc casting (chrome plating), indicator cover: PC, button: stainless steel	
Weight	128g	

Size

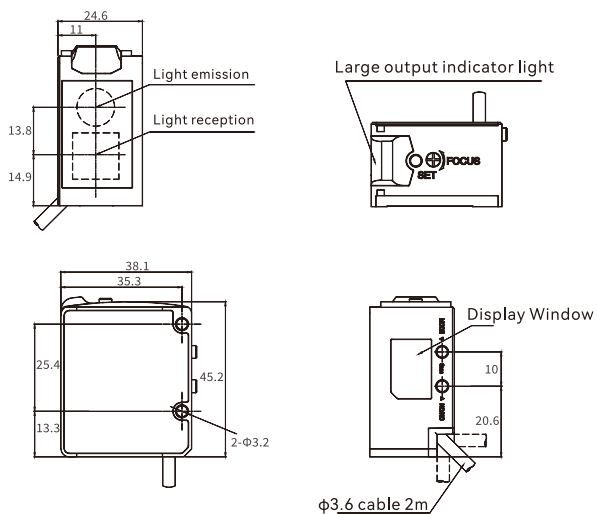

Input / Output Wiring Diagram

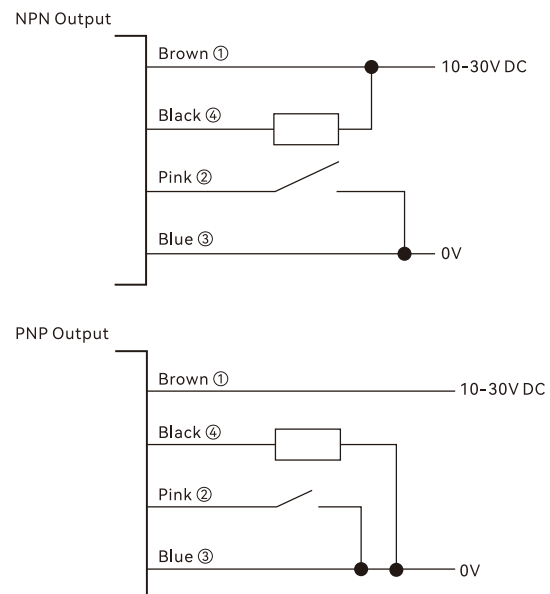

Usage Guidelines

When installing

- Tightening torque of the mounting hole: 0.63 N·m (M3 screw).
- When the detection is unstable, it may be that the detection target is shiny. In this case, tilt the sensor about 15° to 20°.

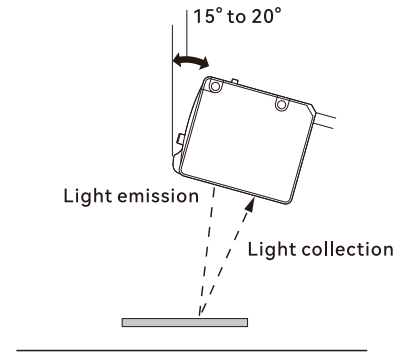

About ambient light

If the light from a high-frequency lighting method such as an inverter fluorescent lamp directly enters or is reflected on the detection target and then enters the receiving unit, malfunction may occur. In this case, take measures such as installing a shading plate or changing the installation position.

Adjust the spot diameter

- The spot diameter can be adjusted with the knob on the side.

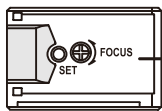

Note: Torque when adjusting the knob: less than 0.2N·m

- Turn it to the right to get closer.

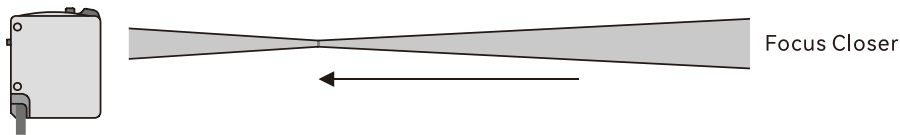

- Turn it to the left to get farther.

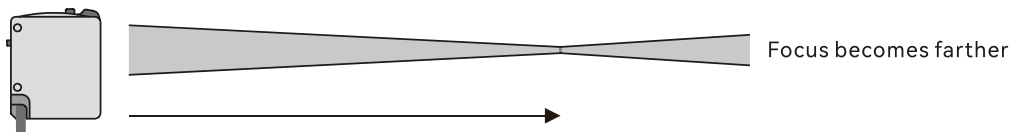

Basic settings

Switch output logic (switch N.O/N.C.)

Setting N.O/N.C.

- n_o (Lon) If the set conditions are met, the output will be ON (ON when light enters)
- n_c (dOn) If the set conditions are not met, the output will be ON (ON when no light enters)

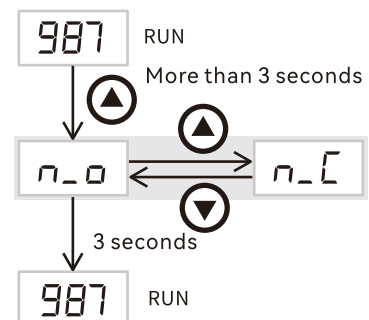

Detection Mode

Detection mode	Description
Auto (initial value)	When adjusting sensitivity, automatically select the most appropriate mode from C+I mode or C mode
C+I mode	Use color components (R, G, B) and brightness (detected by the amount of light received)
C mode	Use color components (R, G, B) to detect
Super I mode	Use brightness (detected by the amount of light received)

Adjust sensitivity

Auto /C+I/C mode

About display value

· Consistency

Displays the degree of consistency between the "color" of the detection target set as the reference and the "color" of the detection target currently being detected.

Display range: 0 to 999 (the more consistent, the larger the value).

· Setting value

The degree to which the "color" of the detection target set as the reference is consistent with the "color" of the detection target is judged as the same "color", and this degree is displayed as the threshold. To confirm or manually fine-tune the setting value, please refer to the tutorial for confirming and adjusting the setting value.

※ The flashing value after tuning is the set value.

Set the sensitivity (select one of the following 3 methods)

· 1-point tuning (when detecting a specified "color")

Set the "color" of the detection target to be used as a reference.
When [Auto] is selected, it will act as [C+I mode].

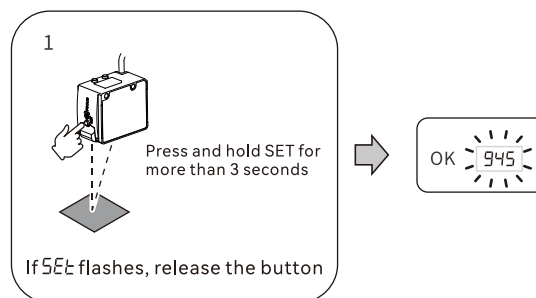

· 2-point tuning (when distinguishing 2 "colors")

Set the "color" of the detection target to be used as the reference and the "color" of the detection target to be distinguished.
(The first point is the reference color.)

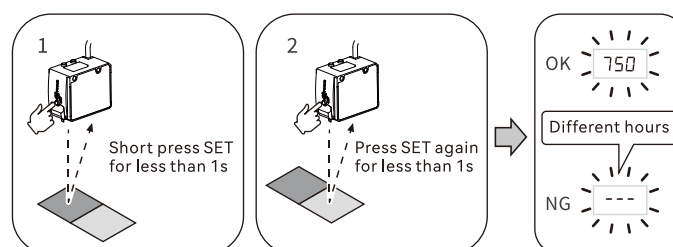

Remove Background

- When the color of the object to be detected is similar to the background color, press SET+△ for 3 seconds facing the background, and release the buttons after the screen flashes to display bCd, which can eliminate the current detection background. This function will be automatically canceled when the sensitivity is reset.

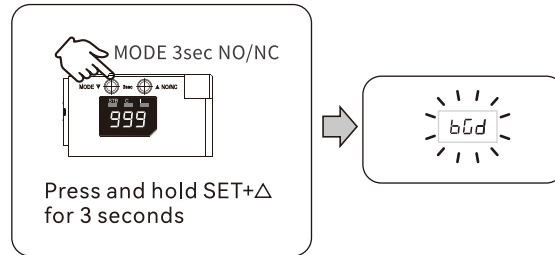

- Standard tuning
(when tolerance is allowed within the same test target)

The "color" of the set detection target is allowed to be uneven and the detection target is biased. When the [SET] button is pressed short, the "color" of the reference is registered, and when it is pressed long, sampling continues. It is set to add a reference during sampling and judge as the same "color". When the reference is added, the indicator flashes green (1 time). When performing standard tuning, the set value becomes 950 (initial value). When changing this value, please refer to the standard tuning setting value. In addition, when [Auto] is selected, it acts as [C + I mode].

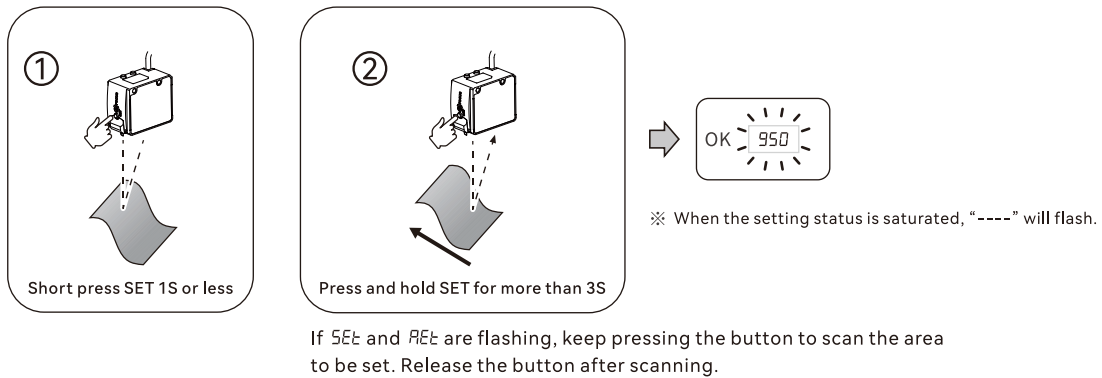

Differential mode

- Detect the difference between two colors without tuning.

This is a function that detects the difference in the consistency between the light spot on one side and the light spot on the other side. No tuning work is required. For example, if the "color" of the two light spots is exactly the same, the displayed value becomes "0", and the larger the color difference, the larger the displayed value.

<Action Example>

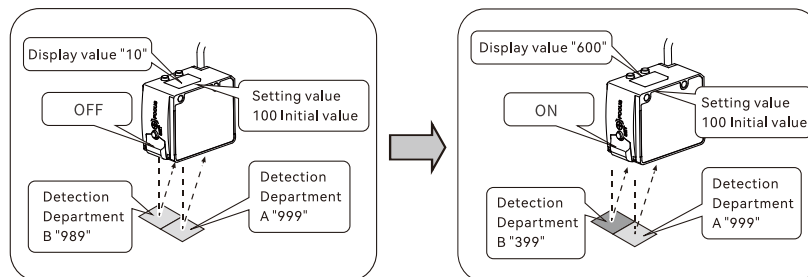

- ※ When confirming or manually fine-tuning the set value, please refer to the above instructions. In [Differential Mode], the larger the set value, the looser the detection, and the smaller the set value, the stricter the detection.

■ Matching mode

· Setting sensitivity

Detect when the consistency of both light spots exceeds the set value ※1
 Register the color combination to be used as a reference and detect ※2

※1 To confirm or manually fine-tune the set value, please refer to the above operation to confirm and adjust the set value.
 ※ When the amount of light received is saturated or insufficient, "UUU" or "HHH" may be displayed. However, if the above registration is performed, light control may be performed and detection can be performed.

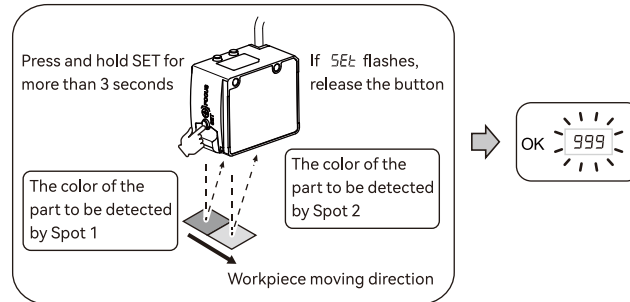

<Action Example>

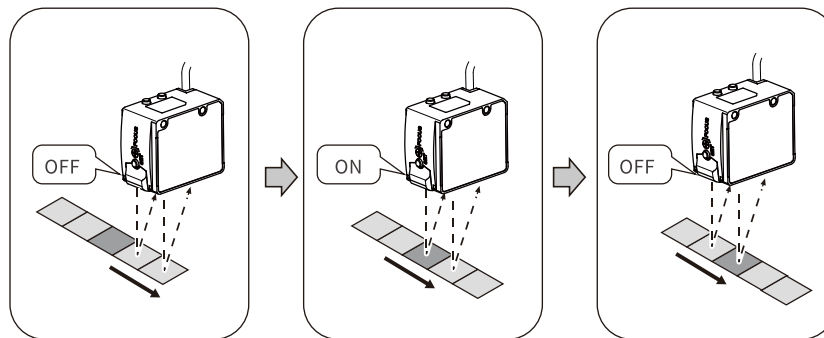

<Notes on standard tuning>

- Continue until the green light indicating additional reference is no longer on.
- If standard tuning is performed again after standard tuning, the settings of the earliest standard tuning will be overwritten.
- If you need to add an allowable range after standard tuning, perform additional standard tuning.
- "HHH" is displayed when the setting status is saturated. If you need to add an allowable range, lower the standard tuning setting value and perform standard tuning again.
- After standard tuning, even if you change the standard tuning setting value, the setting value will not take effect.

■ Tolerable deviation between individual workpieces

· Additional tuning of standard samples (when adding workpieces to be tolerated)

Set the "color" that has been set by other tuning methods and the detection target to be judged as the same "color", and press and hold the [SET] button + [▼] button.

If the additional setting is successful, the "set value" will flash 3 times and return to the normal screen (at this time, the set value will not change).

The "color" between the initially set "color" and the "color" that has been set additionally is also supplemented.

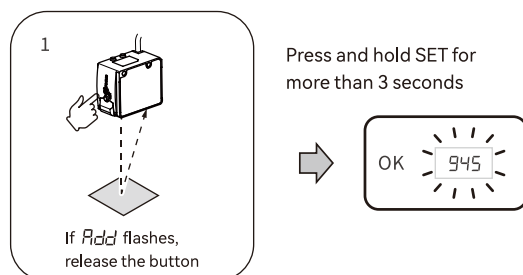

<Notes on additional tuning of standard samples>

- When clearing additional tuning of standard samples, please perform other tuning.
- When the setting fails or the setting status is saturated, "---" is displayed.

■ Confirm and adjust the set value

· The larger the set value, the stricter the detection, and the smaller the set value, the looser the detection.

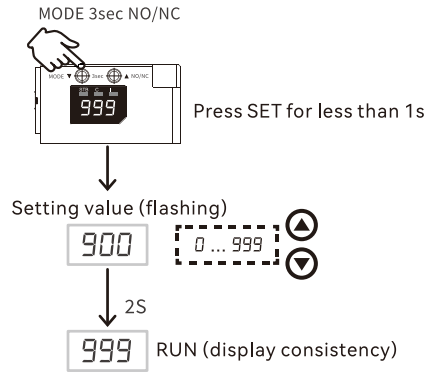

■ Adjust the spot diameter

■ About the displayed value

· Light receiving amount

Displays the current light receiving amount. Display range: 0 to 999 (the more light receiving amount, the larger the value)

· Set value

The light receiving amount is judged as the detection target, and this is displayed as the threshold. When confirming or manually fine-tuning the value, please refer to the tutorial for confirming and adjusting the set value.

※ The flashing value after tuning is the set value.

■ Set sensitivity (select one of the following 3 methods)

· 2-point tuning (basic)

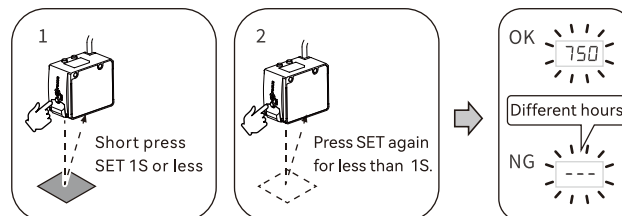

■ Maximum sensitivity tuning (to adjust the sensitivity to the maximum)

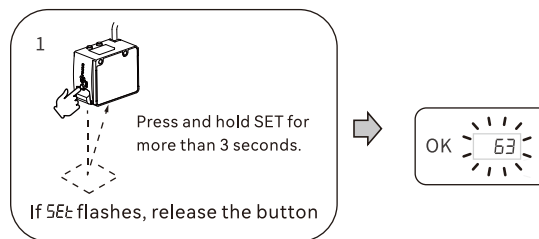

■ Fully automatic tuning (when the moving detection target cannot be stopped)

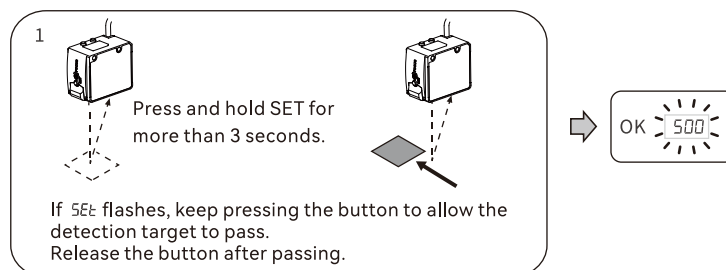

■ Confirm and adjust the set value

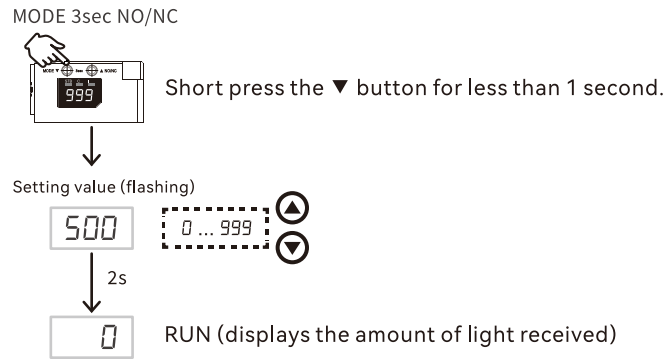

■ Convenient functions

■ Lock key

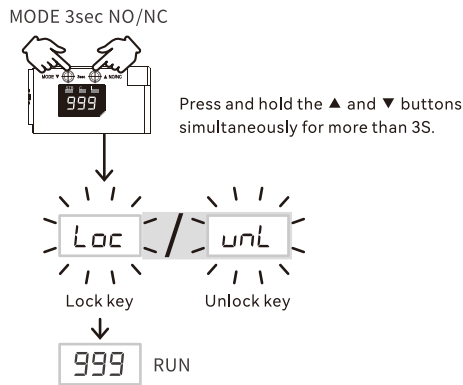

■ Initialization

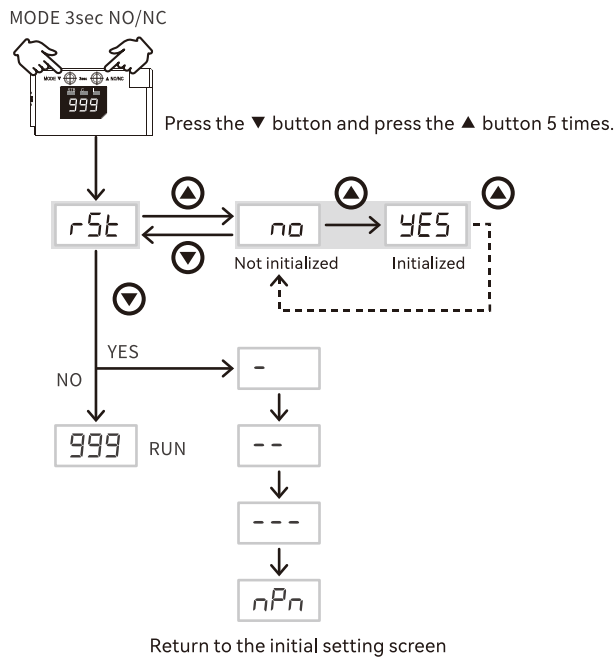

Detailed settings

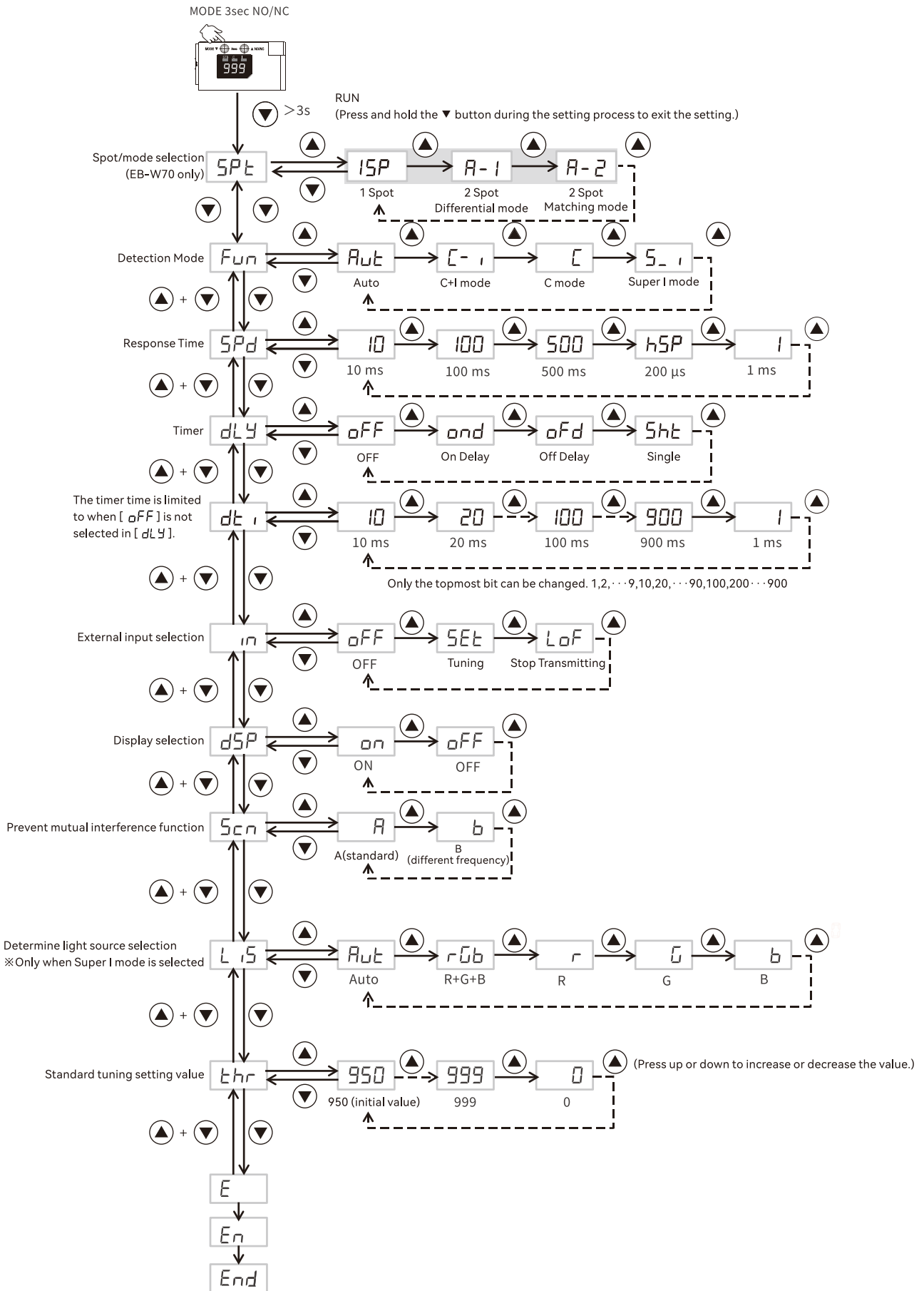

Convenient functions

Detection Mode

Select the detection mode.

Response time

The longer the response time is set, the higher the detection precision and the more accurate it is.

When the detection target moves at high speed or the detection is unstable, the response time should be set shorter.

Timer

This function can delay the output switching of the sensor.

- On delay [*oNd*]
- Off delay [*oFd*]
- Single [*SEt*]

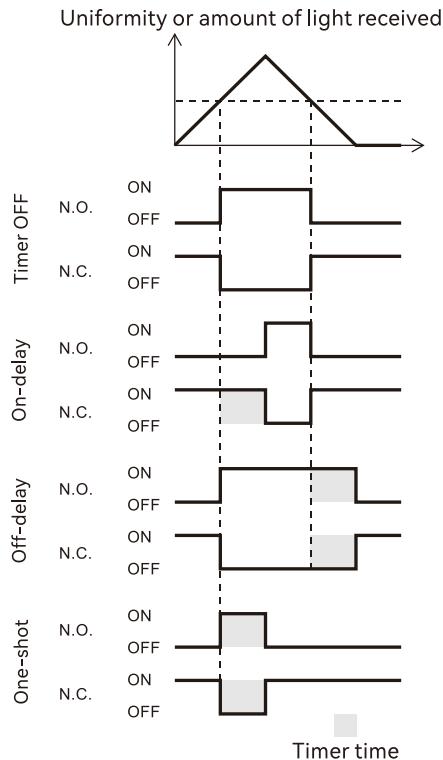

External Input Selection

Tuning [*SEt*]

Performs the same function as the [SET] button.

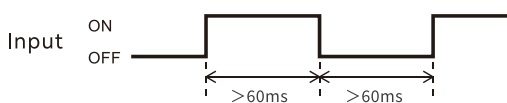

Stop transmitting [*LoF*]

Stop LED transmitting.

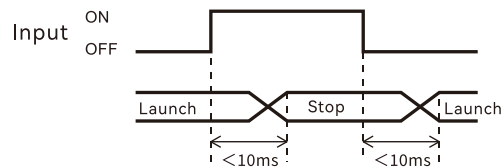

Display selection

Select [*oFF*] to turn off the display.

Mutual interference prevention function

This product can reduce the influence of mutual interference by changing the lighting cycle.

When using multiple products in close proximity, set the lighting cycle to different ones.

Determine the light source selection

When selecting Super|mode, the RGB light source used is determined. When selecting [Auto], the sensor automatically selects the most suitable one when setting the sensitivity.

Select [R+G+B], [R], [G], [B] to fix it.

Standard tuning setting value

When using [Auto/C+I/C mode], the value set when performing standard tuning becomes a fixed value.

This value can be changed in the detailed settings.

The larger the value, the stricter the detection, but when setting standard tuning, "... " is likely to be displayed. If "... " is displayed, please reduce the value and perform standard tuning again.

Other

Non-numeric output

Display	Content	Confirmation items and countermeasures
<i>E r E</i>	1) The set rewrite count has exceeded 1 million times; 2) Memory abnormality.	1) The memory life has expired; 2) If the memory does not reset after reconnecting the power, a fault has occurred.
<i>uuu</i>	In Auto/C+I/C mode, the reflected light is too much, the display is used as a consistency of 0.	Please adjust the sensor setting angle to prevent regular reflected light from entering.
<i>nnn</i>	In Auto/C+I/C mode, the reflected light is insufficient, the display is used as a consistency of 0.	Please confirm whether the detection distance is within the specification range.
<i>L o c</i>	The key lock function is enabled.	Please unlock the key.
Display bar <i>-</i> moves and lights up	The display selection is OFF.	Please set the display selection to ON.

Output of non-numeric display

Display	ON/OFF output		Indicator Lights	
	N.O.	N.C.	N.O.	N.C.
<i>E r E</i>	As Usual		Flashing red	
<i>uuu</i>	OFF	ON	OFF	Orange
<i>nnn</i>	OFF	ON	OFF	Orange
<i>L o c</i>	As Usual		As Usual	
Display bar <i>-</i> moves and lights up	As Usual		As Usual	