

TECHNICAL DATA SHEET

PHOTOELECTRIC SWITCH SENSOR THROUGH-BEAM **EGM18 series**

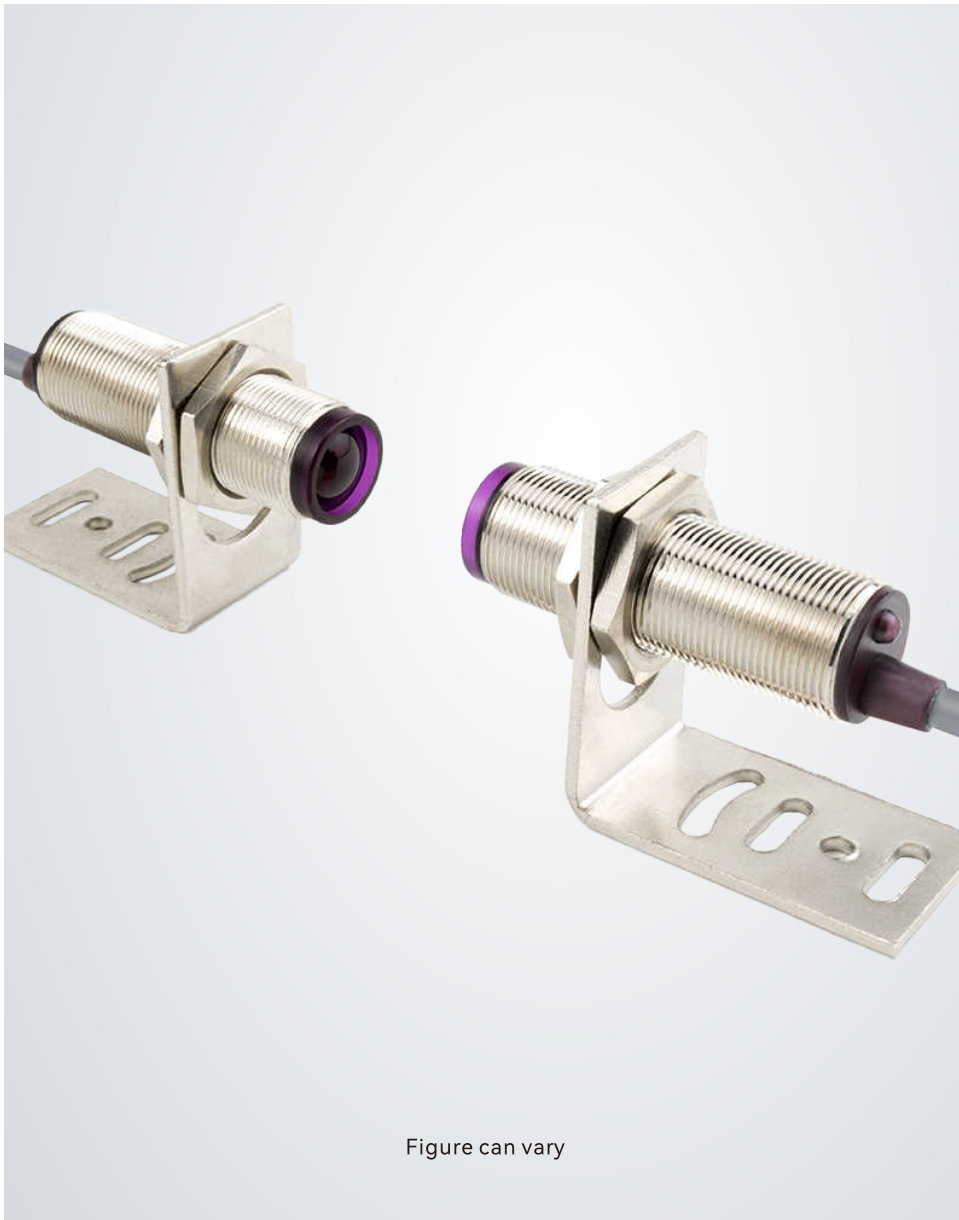

Contents

- Functional Description
- Application Scenarios
- Technical Parameters
- Size parameters
- Wiring method

Product Introduction

The EGM18 cylindrical photoelectric sensor series has a round 18 mm housing. Due to its unique design and superior performance, it has a wide range of application scenarios in multiple fields:

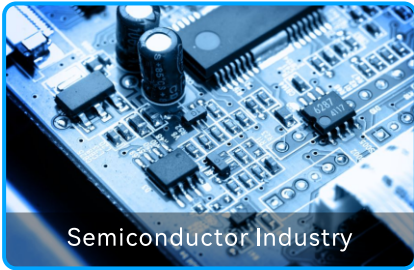

Semiconductor Industry



Logistics Packaging



Electronics Manufacturing



Automation Industry



Textile Industry



Printing Industry

1. In automated production lines, it can be used to detect the position, speed and existence of objects, thereby controlling the movement of equipment such as robotic arms and conveyor belts to ensure smooth and efficient production processes.
2. In the metal processing industry, it can be used to detect tiny objects such as metal chips, debris, etc. to ensure the cleanliness and safety of the production process.
3. It can be used for security applications such as intrusion detection and object tracking. When abnormal objects or personnel are detected, the alarm system can be triggered to ensure the safety of the site.
4. In the manufacturing and testing process of electronic equipment, it can be used to detect the position and integrity of components such as circuit boards and connectors to ensure the quality and performance of communication equipment.

Functional Description

- ⊙ Two scanning ranges are optional;
- ⊙ Free switching between light-incoming action (L.on)/shading action (D.on);
- ⊙ The metal housing is sturdy and durable;
- ⊙ Short-circuit protection and reverse polarity protection functions;
- ⊙ Switching frequency can reach up to 5000Hz;
- ⊙ With 2m cable, fast response time.

Application Scenarios

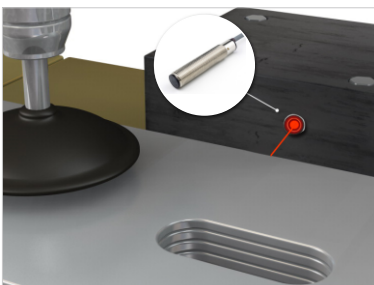

Detecting the presence of parts



Detecting the presence of packaging bottles

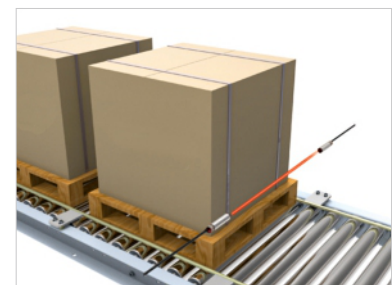

Detecting the positioning of packaging

Photoelectric sensor model specifications

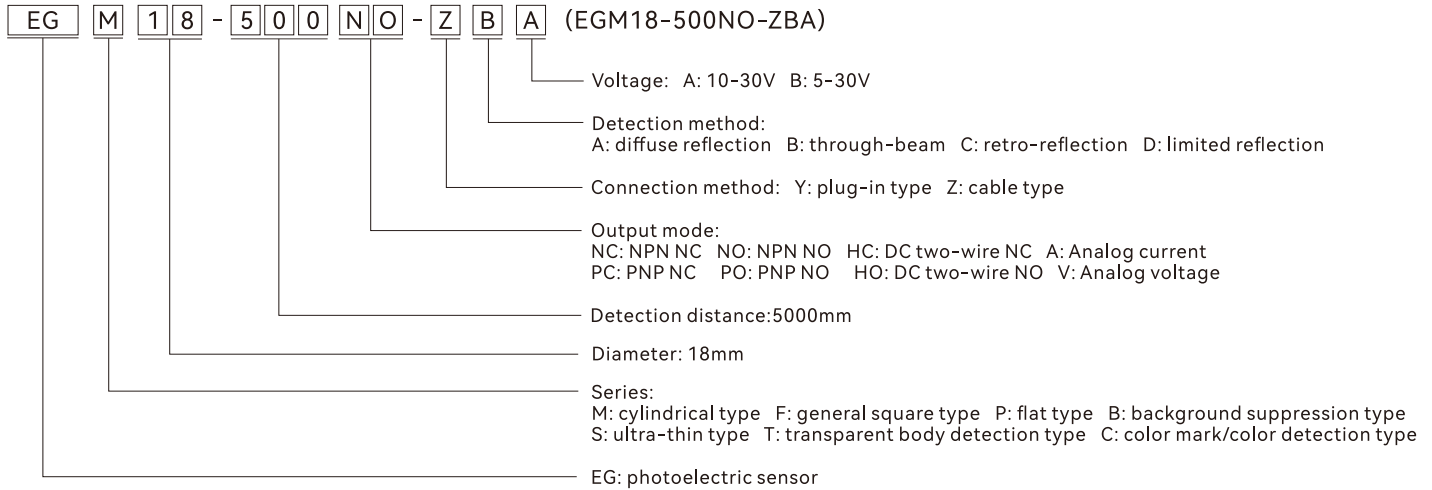

Technical Parameters

Reflection method	Through-beam	
	EGM18-500	EGM18-1500
Model	EGM18-500	EGM18-1500
Detection Distance	5000mm	15000mm
Output Mode	NPN NO / NC, PNP NO / NC	
Repeat Accuracy	< 5%	
Switch Mode	L.on (light-incoming action) / D.on (light-blocking action) switchable	
Indicator Light	Yellow LED	
Response Time	<5ms	
Operating Voltage	10~30V DC	
Consumption Current	<30mA	
Load Current	<200mA	
Operating Temperature	-15°C~+55°C, no freezing	
Environmental Humidity	35%~95%RH, no condensation	
Protection Circuit	Reverse polarity protection/short circuit protection/anti-interference protection	
Protection Level	IP66	
Wire Outlet Method	3pin/4pin with 2M cable	
Material	Nickel-copper alloy	
Light Source	Invisible infrared light (880nm)	

Notes:

- NO:** Normally open. **NC:** Normally closed.
- NPN:** Common positive voltage, negative voltage output. **PNP:** Common negative voltage, positive voltage output.
- NPN NO:** Normally open. When an object is detected, the black line outputs a negative voltage signal.
- NPN NC:** Normally, the black line outputs a negative voltage signal. When an object is detected, the output signal is disconnected.
- PNP NO:** Normally open. When an object is detected, the black line outputs a positive voltage signal.
- PNP NC:** Normally, the black line outputs a positive voltage signal. When an object is detected, the output signal is disconnected.

Size parameters

EGM18-500 size

EGM18-1500 size



Remark: The appearance size of the transmitter and receiver is the same

Wiring method

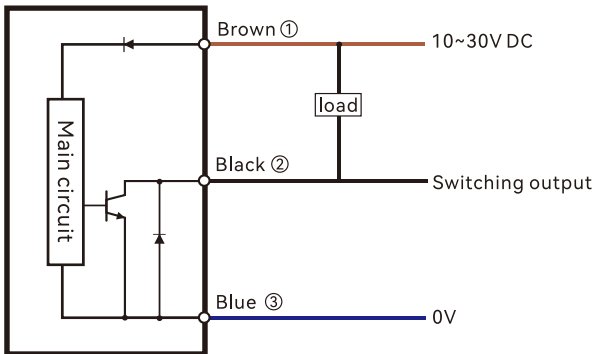

DC 3 line NPN

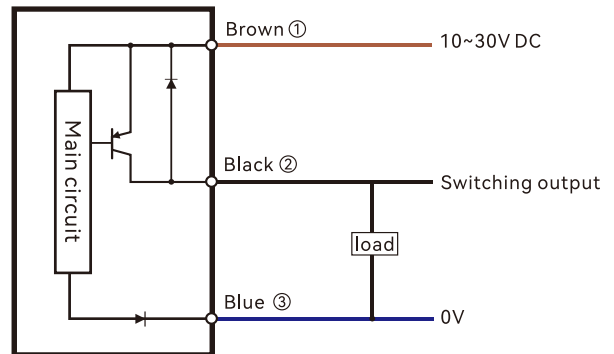

DC 3 line PNP

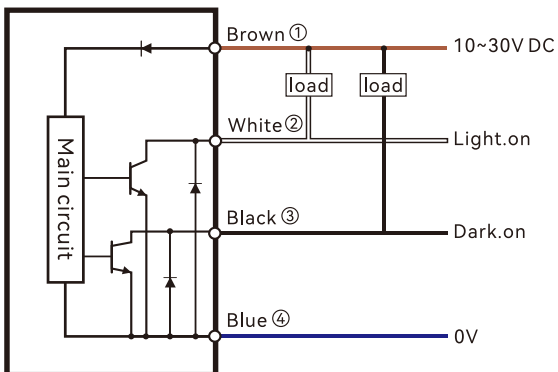

DC 4 line NPN

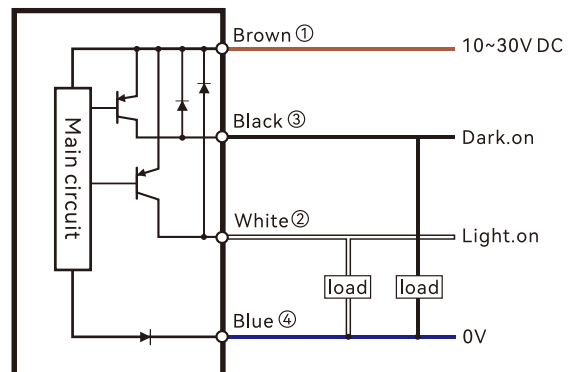

DC 4 line PNP