

TECHNICAL DATA SHEET

LASER DISPLACEMENT SENSOR EGFL-Z series

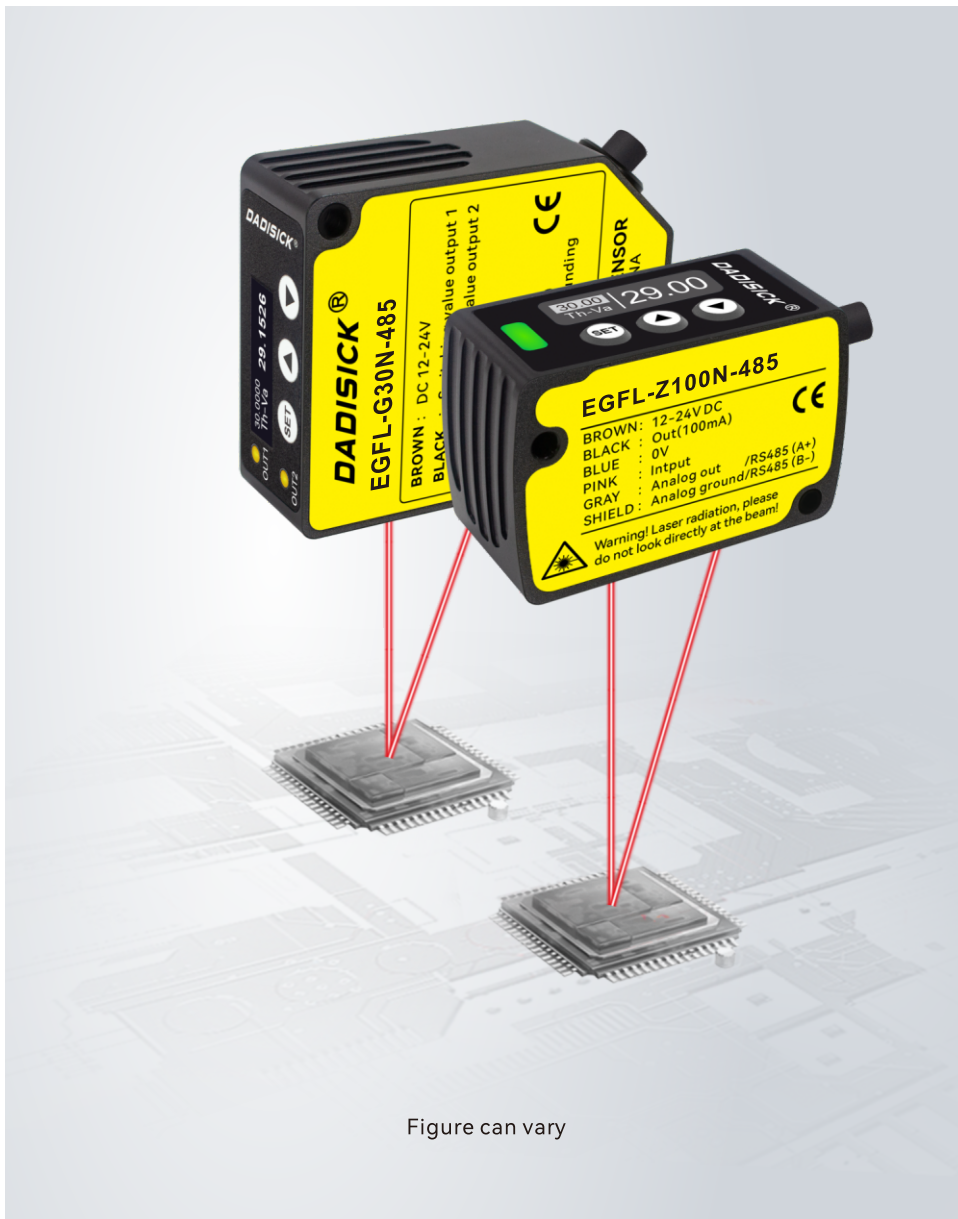

Figure can vary

Contents

- Product Features
- Application Scenario
- Model Selection
- Circuit wiring diagram
- Size parameter
- Installation instructions

EGFL-Z series

Product Features

- Repetitive accuracy 70 μm ;
- High precision micro laser displacement sensor;
- Measurement center distance 100mm, detection range $\pm 35\text{mm}$;
- Small size, small light spot, multiple detection modes, high accuracy.

This product complies with the following specifications/regulations.

< European Specification > EMC Directive

< US/Canada Specification > CAN/CSA-C22.2 NO.60947-5-2-14

Applied the measurement principle of triangulation

When the position of the target changes, the incoming light position on the CMOS will move. Determine the displacement of the target object by detecting the position of the incoming light.



The detection angle needs to be perpendicular to the measured object within $90^\circ \pm 15^\circ$. Transparent objects cannot be detected, liquids cannot be detected, and the range cannot be calculated from 0.

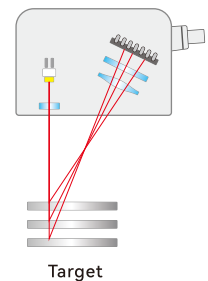

Application Cases

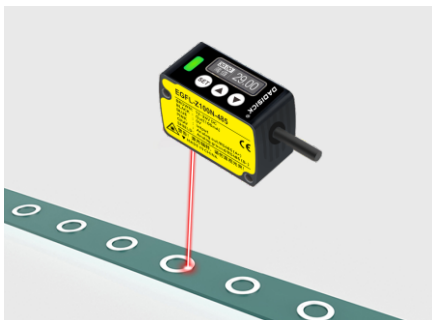

Check the presence of gaskets



Detection of bending amount



Measurement of camshaft shape

Multiple models available

Model	EGFL-Z30 Series	EGFL-Z50 Series	EGFL-Z100 Series	EGFL-Z200 Series	EGFL-Z400 Series
Detection distance	30mm	50mm	100mm	200mm	400mm
Detection range	±5mm	±15mm	±35mm	±80mm	±200mm
Accuracy	10µm	30µm	70µm	200µm	400µm



Within range
measuring range 25-35mm

EGFL-Z30 Series

Detection distance: **30mm**
Detection range: **±5mm**
Accuracy: **10µm**



Within range
measuring range 35-65mm

EGFL-Z50 Series

Detection distance: **50mm**
Detection range: **±15mm**
Accuracy: **30µm**



Within range
measuring range 65-135mm

EGFL-Z100 Series

Detection distance: **100mm**
Detection range: **±35mm**
Accuracy: **70µm**



Within range
measuring range 120-280mm

EGFL-Z200 Series

Detection distance: **200mm**
Detection range: **±80mm**
Accuracy: **200µm**



Within range
measuring range 200-600mm

EGFL-Z400 Series

Detection distance: **400mm**
Detection range: **±200mm**
Accuracy: **400µm**

Product parameters table

species		Measuring center 30mm	Measuring center 50mm	Measuring center 100mm	Measuring center 200mm	Measuring center type 400mm
Output type	NPN output		EGFL-Z50N	EGFL-Z100N	EGFL-Z200N	EGFL-Z400N
	Analog output	EGFL-Z30NM	EGFL-Z50NM	EGFL-Z100NM	EGFL-Z200NM	EGFL-Z400NM
	RS485 output	EGFL-Z30N-RS485	EGFL-Z50N-RS485	EGFL-Z100N-RS485	EGFL-Z200N-RS485	EGFL-Z400N-RS485
Measuring center distance		30mm	50mm	100mm	200mm	400mm
Measuring range		±5mm	±15mm	±35mm	±80mm	±200mm
Repeatability		10μm	30μm	70μm	200μm	400μm(Measuring distance200~400mm) 800μm(Measuring distance400~600mm)
Straightness		±0.1%FS.			±0.2%FS.	±0.2%FS.(Measuring distance200~400mm) ±0.2%FS.(Measuring distance400~600mm)
Temperature characteristic		0.03%FS./°C				
Illuminant		Red semiconductor laser Class 2 Maximum output :1mW, light beam wavelength :655nm				
Beam diameter		About φ50μm	About φ70μm	Aboutφ120μm	About φ300μm	About φ500μm
Supply voltage		12~24V DC±10%, pulsation P-P10%				
Current consumption		Below 40mA (24V DC supply voltage), below 60mA (12VDC supply voltage)				
Control output		<p><NPN output type ></p> <p>NPN open collector transistor</p> <ul style="list-style-type: none"> ● Maximum inflow current :50mA ● Applied voltage :30V DC below (control output -0V) ● Residual voltage: less than 1.5V (inflow current 50mA) ● Leakage current: below 0.1mA 				
Output action		ON in light/ON in non-light can be switched				
Short circuit protection		Equipped (automatic recovery type)				
Analogoutput	Voltage analog output (When alert :+5.2V)	Output range :0 to 5V Output impedance100Ω		Output range:0~5V Output impedance: 100Ω		Output range:0~5V Output impedance: 100Ω
	Current analog output (Alert :0mA)	Output range :4 to 20mA Load impedance :300Ω or less		Output range :4 to 20mA Load impedance :300Ω or less		Output range :4 to 20mA Load impedance :300Ω or less
Reaction time		1.5ms/5ms/10ms can be switched				
External input		NPN No contact input Valid :0V to +12V DC Input impedance: about 10 kΩ				
Protective construction		IP60				
Degree of fouling		2				
Operating ambient temperature		-10°C~+40°C(pay attention to do not condensation, icing), storage : -20°C~+60°C				
Ambient humidity		35%~85%RH, storage :35%~85%RH				
Use ambient light		Incandescent lamp: the illumination degree of the illuminated surface is less than 3000lx				
Service level		Below 2000m				
Cable		With 0.15mm 5-core composite cable 2m				
Material		Body shell: aluminum casting front cover plate: propylene base				
Weight		Approx. 35g(without cable), Approx. 85g(with cable)				
Applicable specification		Compliance with EMC directive				

(Note): When the measurement conditions are not specified, the use conditions are as follows: power supply voltage :24V DC, ambient temperature :+20°C, reaction time :10ms, analog output value of the measurement center distance. Object Object: White paper.

Circuit wiring diagram

Display the threshold value and current detection value when powered on.
Red indicator light for output, green for power supply

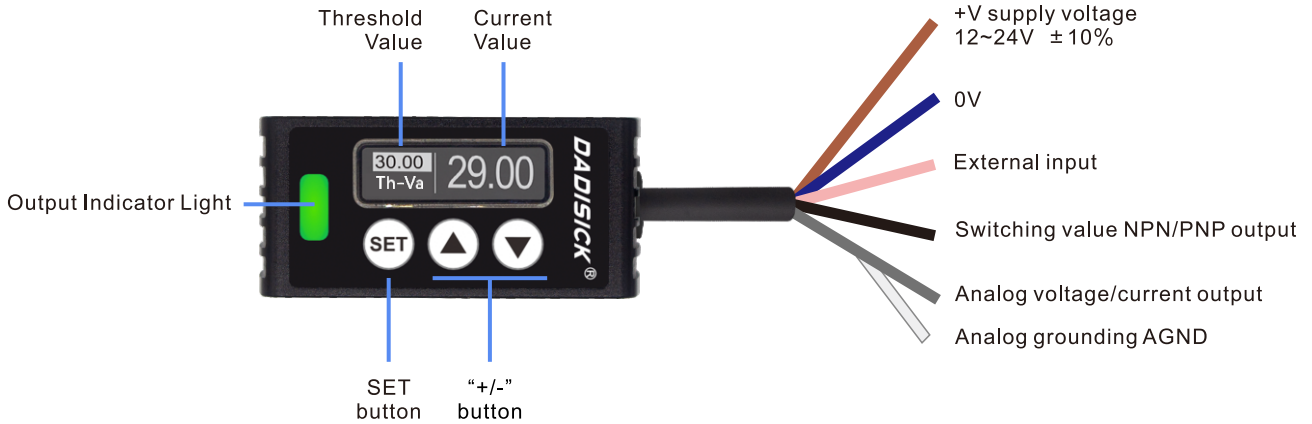

Input/output circuit diagram:

- NPN+ analog output type (RS485 output)

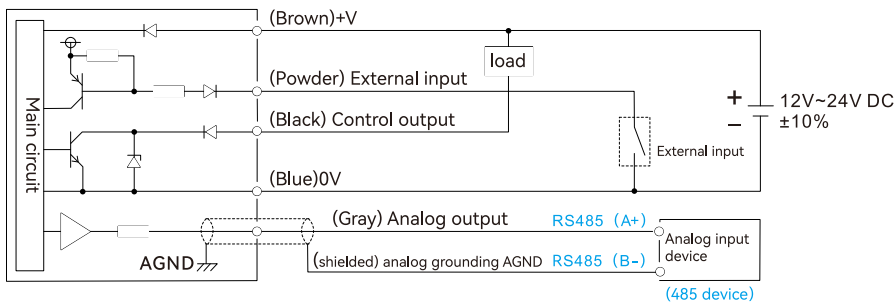

- PNP+ analog output type (RS485 output)

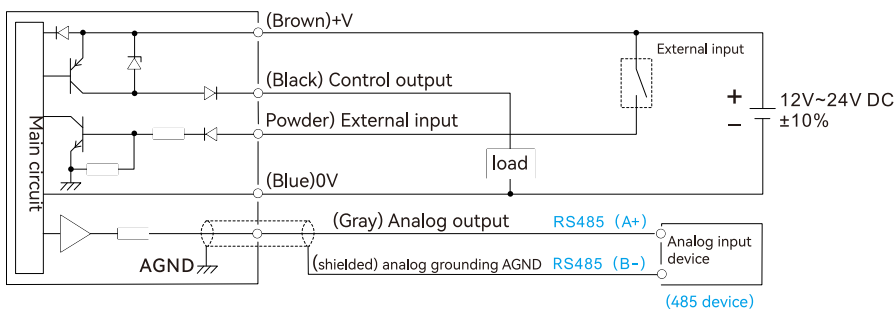

Outline Dimensional Drawing

Unit: mm

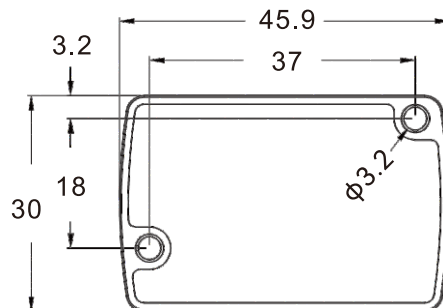
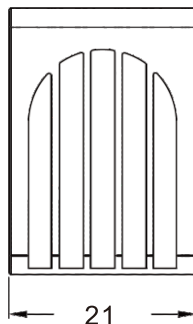

Installation instructions

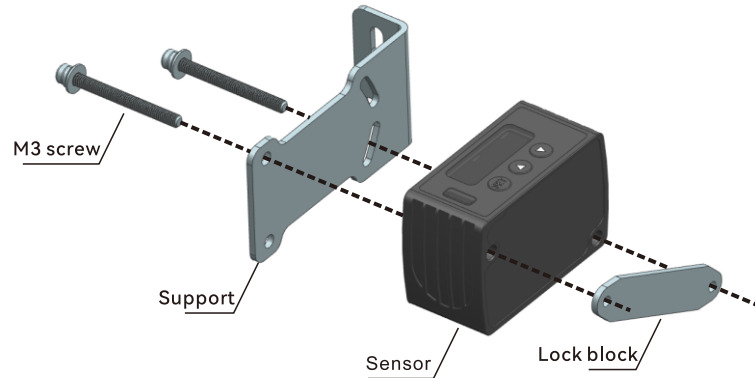

Installation direction

- Relative to the direction of movement
<In case of material and color difference>

When measuring, when the material and color of the moving measurement object are extremely different, install it in the direction shown in the following figure to minimize measurement errors.

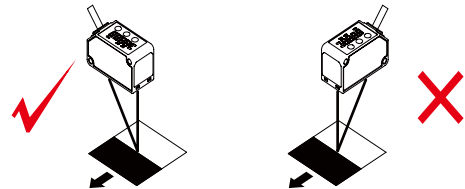

<Measure rotating objects>

- When measuring a rotating object, install it in the direction shown in the following figure to suppress the effects of vibration and position deviation of the object.

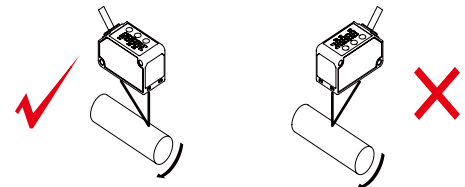

<In the case of a gap>

- When there is a segment difference in the moving measurement object, install it according to the method shown in the following figure to suppress the influence of the segment difference edge.

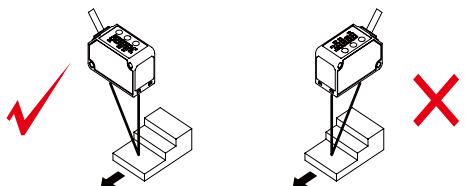

<Measure in narrow areas and sunken areas>

- When measuring in narrow areas and recessed areas, please be careful not to obstruct the optical path from the projecting part to the receiving part during installation.

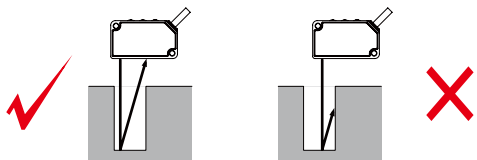

When installing the sensor section on the wall>

- Please install according to the method shown in the following figure to prevent the multiple reflected light generated by the wall from entering the light receiving part. In addition, when the reflectivity of the wall is high, changing to a matte black color can achieve good results.

