

TECHNICAL DATA SHEET

Economic Laser Scanning Radar ELD-05H series

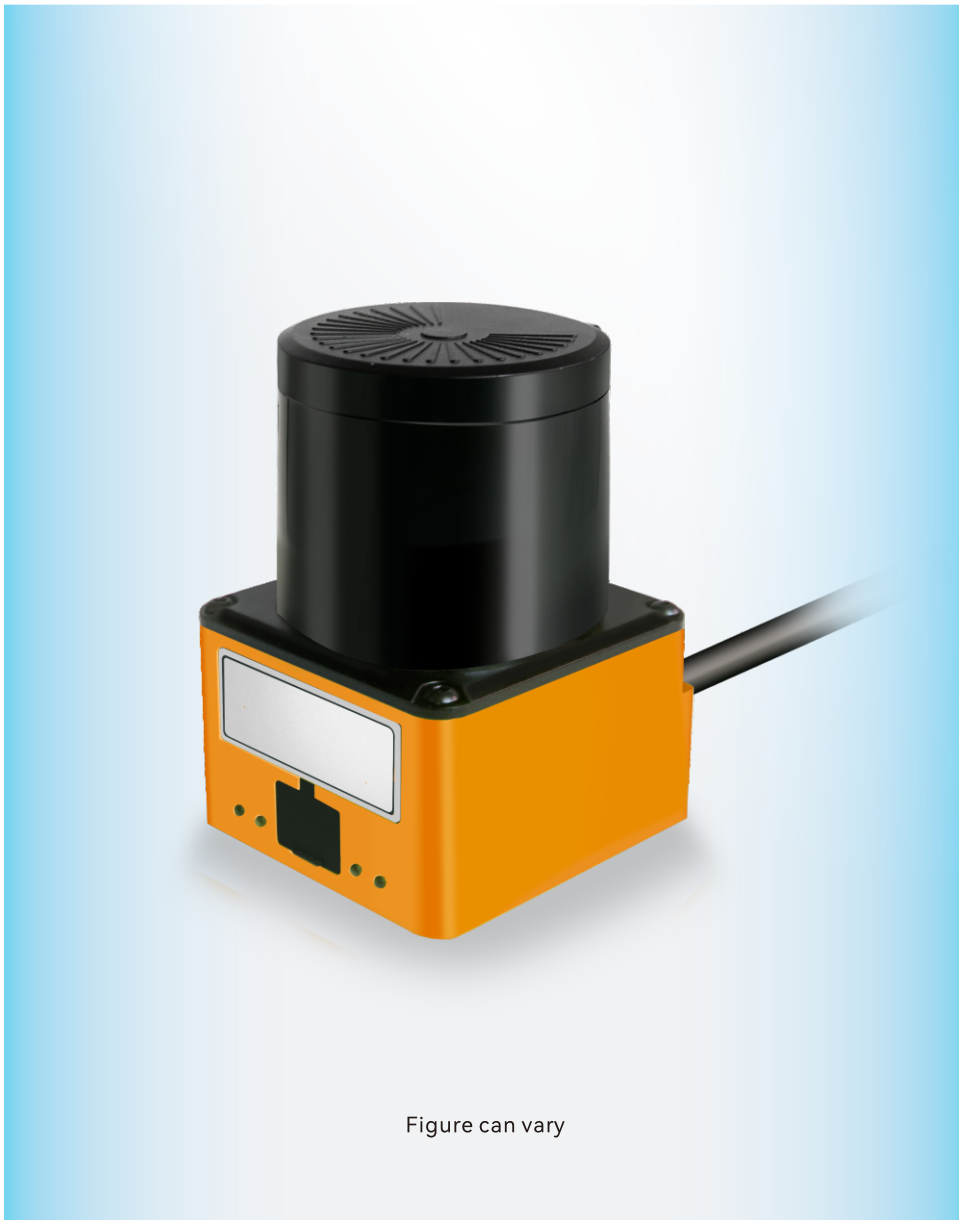

Figure can vary

Contents

- Product Features
- Performance Parameters
- Size parameter
- Installation instructions
- Circuit wiring diagram

ELD-05H series

Product Features

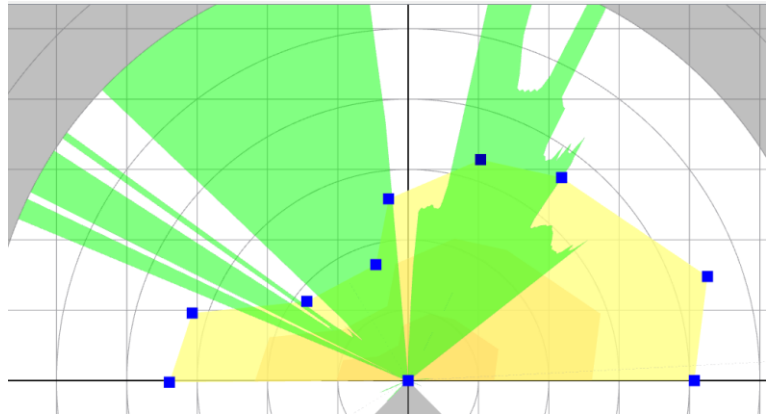

50ms

Response time

0.5°

Angular resolution

5-10m

Sensing distance

270°

Scanning angle

Product Performance

LiDAR operates based on the principle of time-of-flight (TOF) measurement. Under a very high synchronous clock, the laser is emitted at uniform time intervals. When the laser beam encounters an object, it is reflected back. After the scanning sensor receives the reflected beam, the distance from the laser sensor to the object is calculated by the time difference Δt between emission and reception.

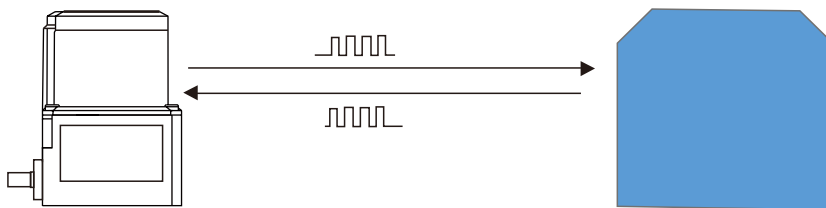

$$\Delta t = \frac{t}{2}$$

$$S = v * \Delta t$$

s: measured distance

v: laser flight speed

Δt : time difference

t: laser flight time (round trip)

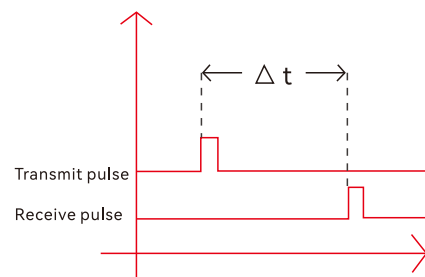

Performance parameters

Basic characteristics		
Product model	ELD-05HN	ELD-05HP
Working area	0.05-3m(10%) 0.05-5m(90%)	
Product model	ELD-10HN	ELD-10HP
Working area	0.05-6m(10%) 0.05-10m(90%)	
Detection range	270°	
Laser light source	Infrared laser (905nm)	
Performance		
Response time	Typical Value 50ms	
Basic error	40mm	
Statistical error	30mm	
Number of channels	64 (each channel contains 3 detection areas)	
Detection output delay	Settable within the range of 0ms-500ms	
Detection hold delay	Settable within the range of 0ms-500ms	
Detection size filtering angle	Settable within the range of 0.5°-5°	
Interface		
Configuration port	1 (Micro-UsB)	
Switch input	6 (PNP)	
Switch output	4 (3 detection signals, 1 fault signal), single-channel load capacity 100mA	
Indicator light	4 (3 detection signal lights, 1 status light)	
Electrical performance		
Working voltage	DC18-32V	
Current consumption	60mA typical (without output load)	
Working environment		
Object reflectivity	5%-1000%	
Working environment	-10°C-50°C	
Ambient light intensity	< 15000lx	

Product size

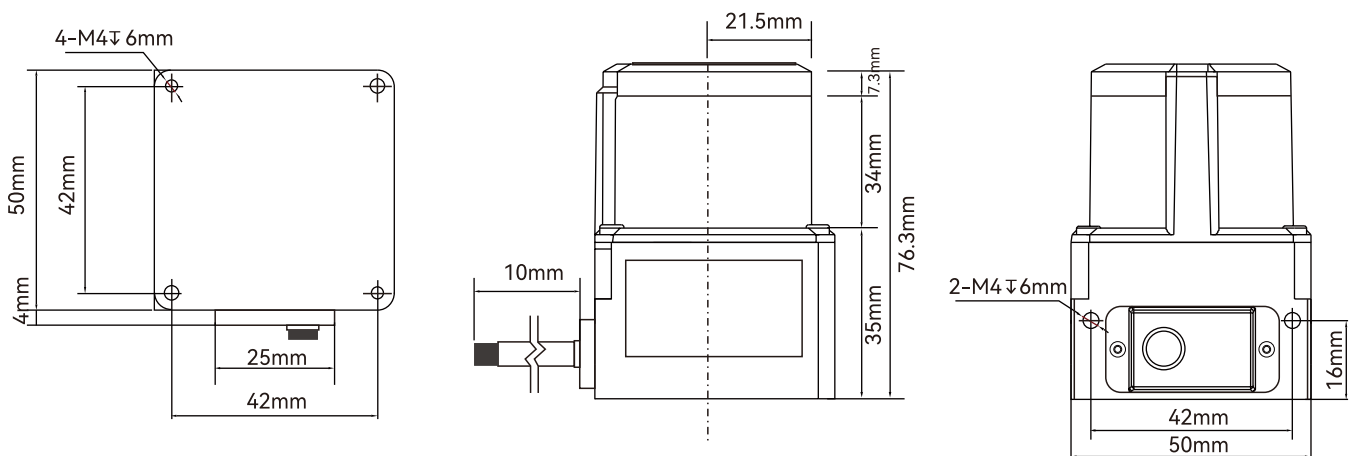

Installation Requirements

The laser scanning sensor comes with a cable, and the cable position needs to be reserved to avoid excessive bending of the cable. The Micro USB jack position and indicator light position should be reserved in front of the laser scanning sensor base to facilitate connection debugging and observation of sensor status.

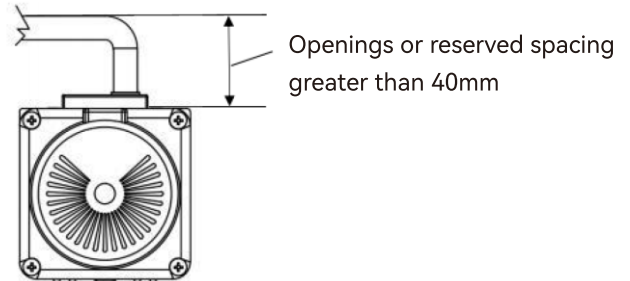
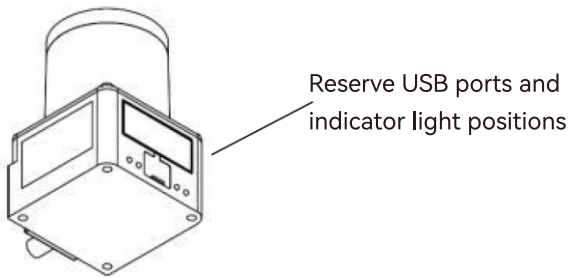

Front installation diagram

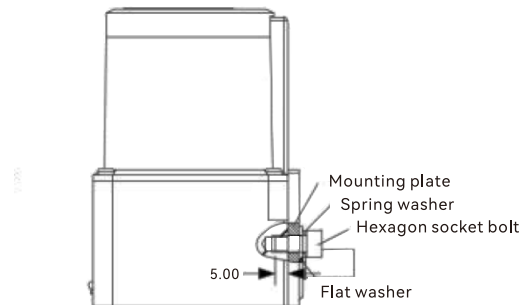
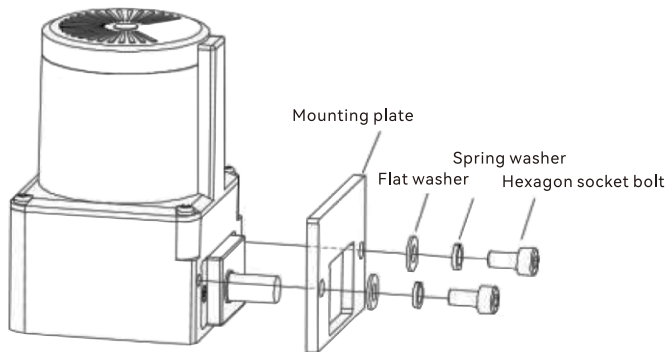

Bottom installation diagram

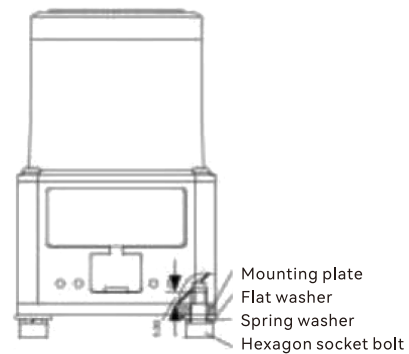
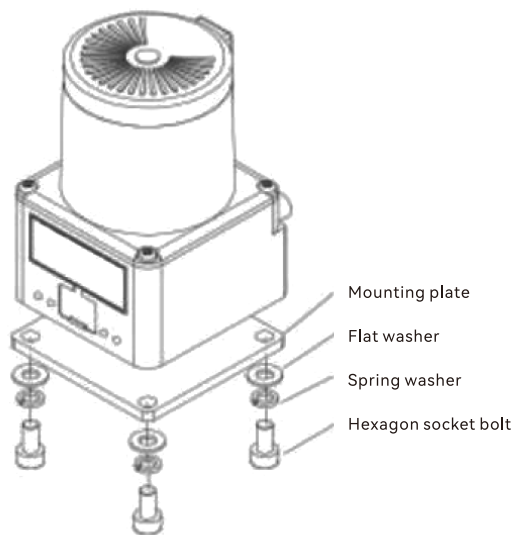

Use screw specifications

Screw specifications	Tightening torque
M4*10mm	0.1N.M

ELD-05H series radar wiring diagram

The sensor cable leads to 14 core wires, and the wire color definition corresponds to the following table

Colors	Model Type	Signal	Function Description
Brown	Power supply	DC 24V	Positive pole of power supply 18-32V
Blue	Power supply	0V	Negative pole of power supply
White Brown	Common terminal	INCOM	Input common terminal
Black	Input	IN1	Input port 1
Orange		IN2	Input port 2
Yellow		IN3	Input port 3
Green		IN4	Input port 4
Purple		IN5	Input port 5
Gray		IN6	Input port 6
White	Common terminal	OUTCOM	Output common terminal
White Green	Output	OUT1	Warning: Zone 2 has sensed an object and the port has acted
White Blue		OUT2	Warning: Zone 1 has sensed an object and the port has activated
Red		OUT3	The port will act when the protected area senses an object
White Red		ERROR OUT	Port action when sensor fails

NPN Wiring Diagram

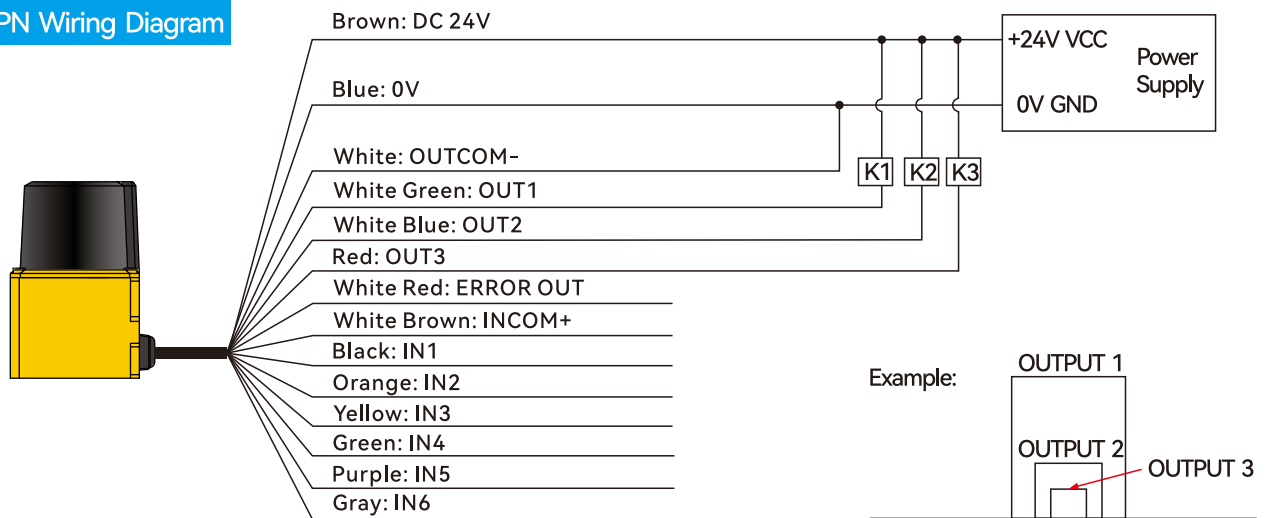

PNP Wiring Diagram

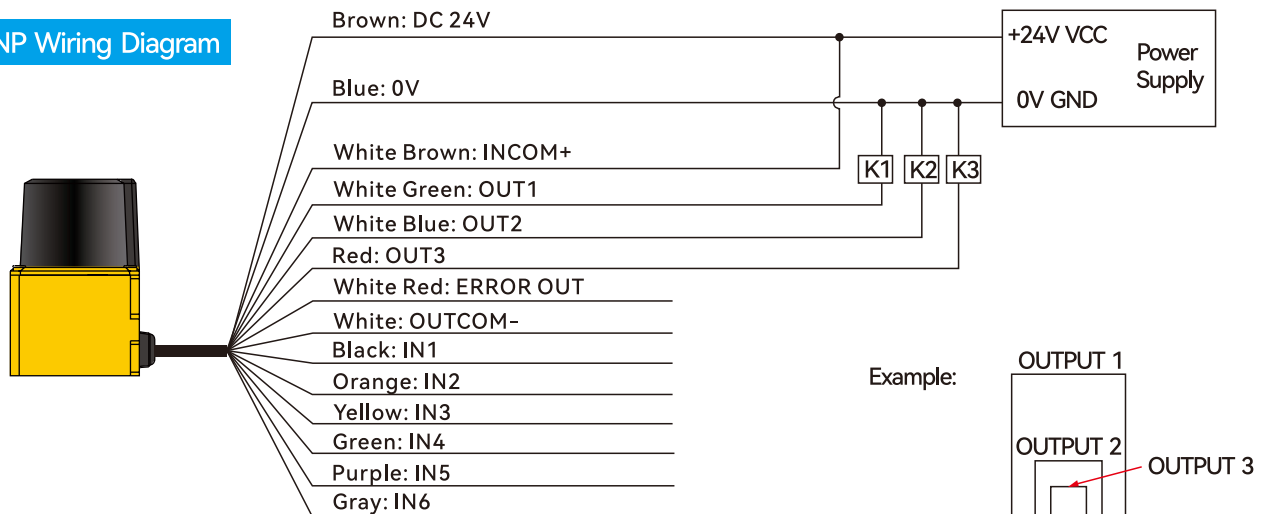

ELD-10H series radar wiring diagram

The sensor cable leads to 14 core wires, and the wire color definition corresponds to the following table

Colors	Model Type	Signal	Function Description
Brown	Power supply	DC 24V	Positive pole of power supply 18-32V
Blue	Power supply	DC0V	Negative pole of power supply
White Brown	RS232	RX	RS232 RX port
Orange		TX	RS232-TX port
Yellow		GND	RS232-GND port
Green	RS485	A	RS485 port A
Purple		B	RS485 port B
Gray		GND	RS485 GND port
White	CAN BUS	CAN-H	CAN H position
White Green		CAN-L	CAN L position
White Blue		CAN-D	CAN-GND
Black	Output	COM-	Output public end
Red		OUT3	OUT3 output port
White Red		Error OUT	Port action when sensor failure occurs

NPN Wiring Diagram

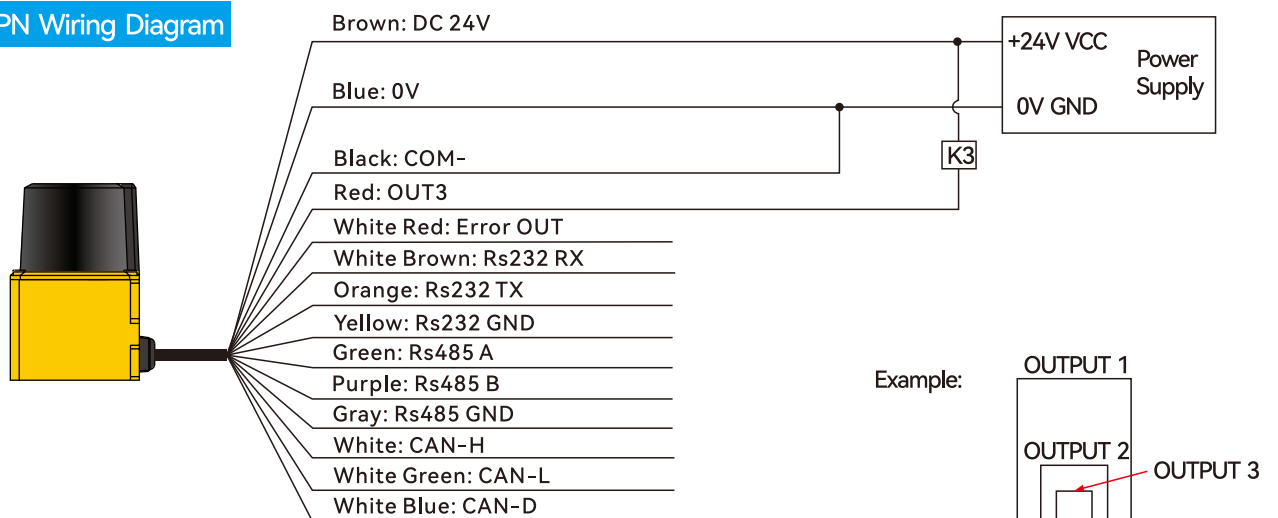

PNP Wiring Diagram

