

TECHNICAL DATA SHEET

PHOTOELECTRIC SWITCH SENSOR DIFFUSE **DK-GM12 series**

Contents

- Functional Description
- Application Scenarios
- Technical Parameters
- Size parameters
- Wiring method



Product Introduction

The DK-GM12 cylindrical photoelectric sensor series has a round 12 mm housing. Due to its unique design and superior performance, it has a wide range of application scenarios in multiple fields:

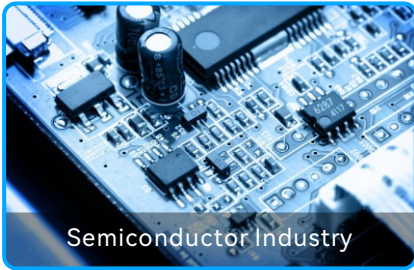

Semiconductor Industry



Logistics Packaging



Electronics Manufacturing



Automation Industry

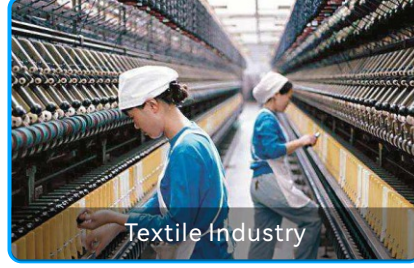

Textile Industry



Printing Industry

1. In automated production lines, it can be used to detect the position, speed and existence of objects, thereby controlling the movement of equipment such as robotic arms and conveyor belts to ensure smooth and efficient production processes.
2. In the metal processing industry, it can be used to detect tiny objects such as metal chips, debris, etc. to ensure the cleanliness and safety of the production process.
3. It can be used for security applications such as intrusion detection and object tracking. When abnormal objects or personnel are detected, the alarm system can be triggered to ensure the safety of the site.
4. In the manufacturing and testing process of electronic equipment, it can be used to detect the position and integrity of components such as circuit boards and connectors to ensure the quality and performance of communication equipment.

Functional Description

- ⊙ Three scanning ranges are optional and the detection distance is adjustable;
- ⊙ Free switching between light-incoming action (L.on)/shading action (D.on);
- ⊙ The metal housing is sturdy and durable;
- ⊙ Short-circuit protection and reverse polarity protection functions;
- ⊙ Switching frequency can reach up to 5000Hz;
- ⊙ With 2m cable, fast response time.

Application Scenarios

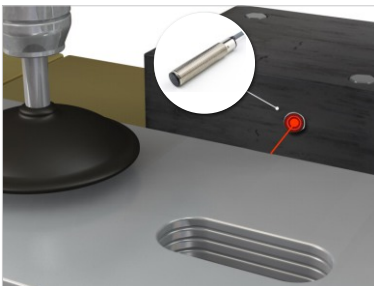

Detecting the presence of parts



Detecting the presence of packaging bottles

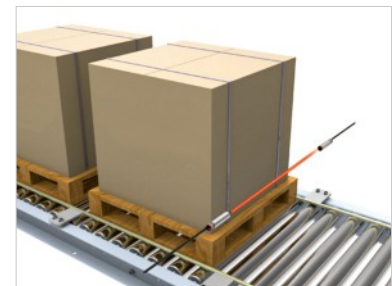

Detecting the positioning of packaging

Photoelectric sensor model specifications

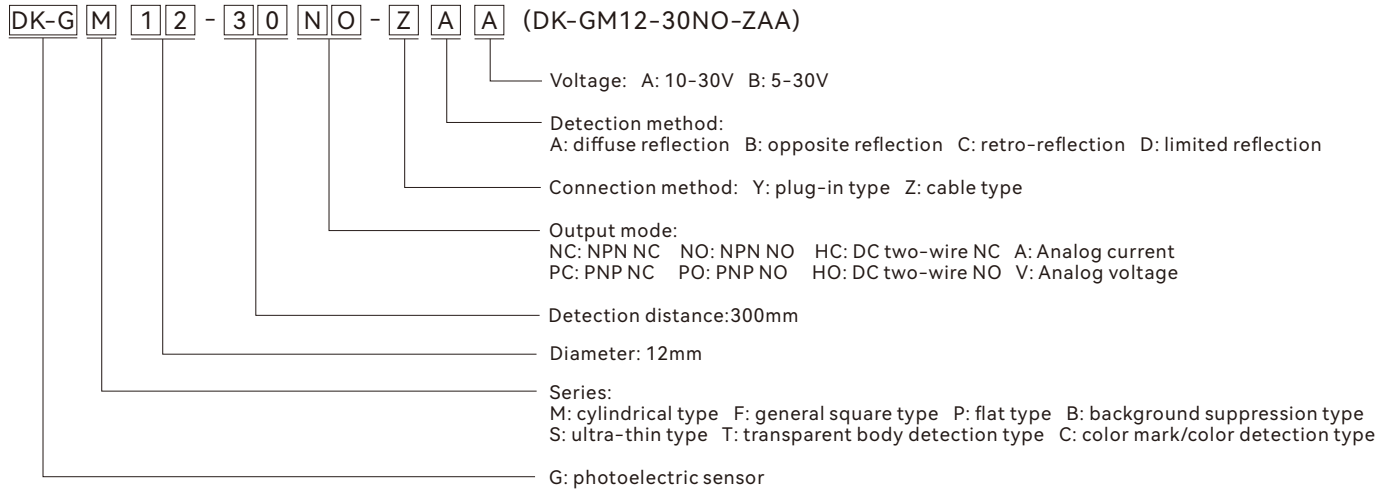

Technical Parameters

Reflection method	Diffuse reflection (adjustable)		
Model	DK-GM12-10	DK-GM12-20	DK-GM12-30
Detection Distance	20-100mm	20-200mm	20-300mm
Output Mode	NPN NO / NC, PNP NO / NC		
Repeat Accuracy	< 5%		
Switch Mode	L.on (light-incoming action) / D.on (light-blocking action) switchable		
Indicator Light	Yellow LED		
Response Time	<5ms		
Operating Voltage	10~30V DC		
Consumption Current	<30mA		
Load Current	<200mA		
Operating Temperature	-15°C~+55°C, no freezing		
Environmental Humidity	35%~95%RH, no condensation		
Protection Circuit	Reverse polarity protection/short circuit protection/anti-interference protection		
Protection Level	IP66		
Wire Outlet Method	3pin/4pin with 2M cable		
Material	Nickel-copper alloy		
Light Source	Invisible infrared light (880nm)		

Notes:

- 1.NO:** Normally open. **NC:** Normally closed.
- 2.NPN:** Common positive voltage, negative voltage output. **PNP:** Common negative voltage, positive voltage output.
- 3.NPN NO:** Normally open. When an object is detected, the black line outputs a negative voltage signal.
- 4.NPN NC:** Normally, the black line outputs a negative voltage signal. When an object is detected, the output signal is disconnected.
- 5.PNP NO:** Normally open. When an object is detected, the black line outputs a positive voltage signal.
- 6.PNP NC:** Normally, the black line outputs a positive voltage signal. When an object is detected, the output signal is disconnected.

Size parameters

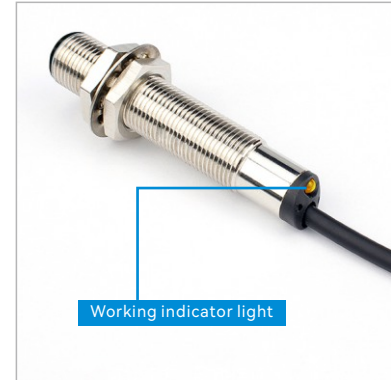

Wiring method

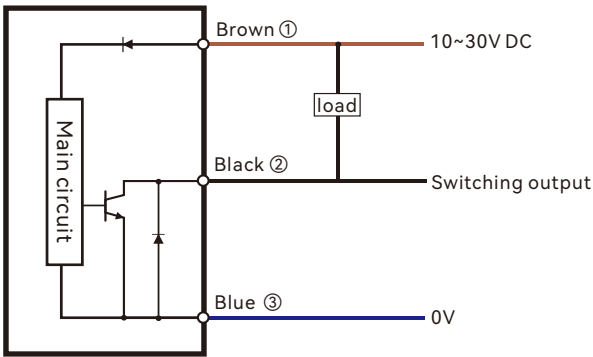

DC 3 line NPN

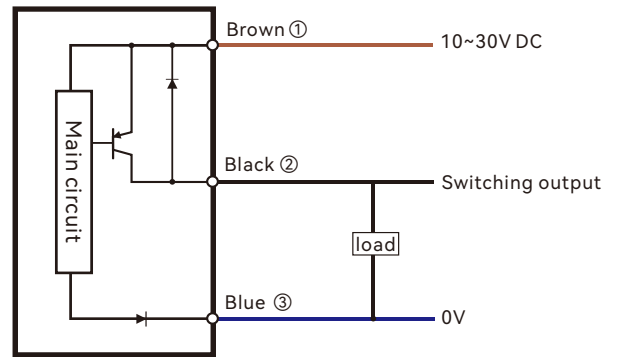

DC 3 line PNP

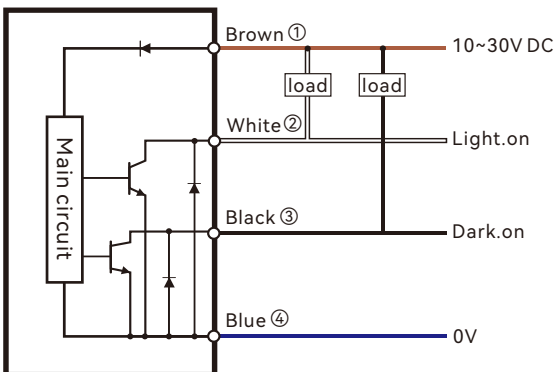

DC 4 line NPN

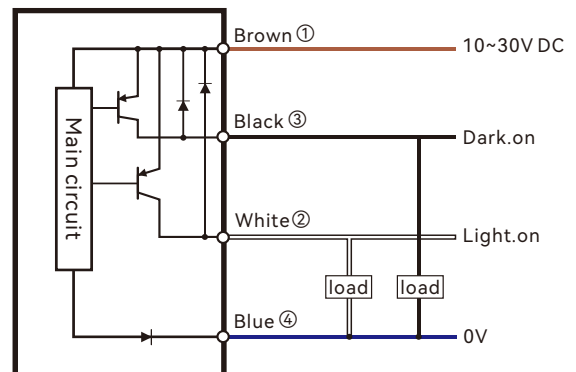

DC 4 line PNP