

# USER'S MANUAL

---

## OPTICAL DATA TRANSMISSION DK-ST100 series

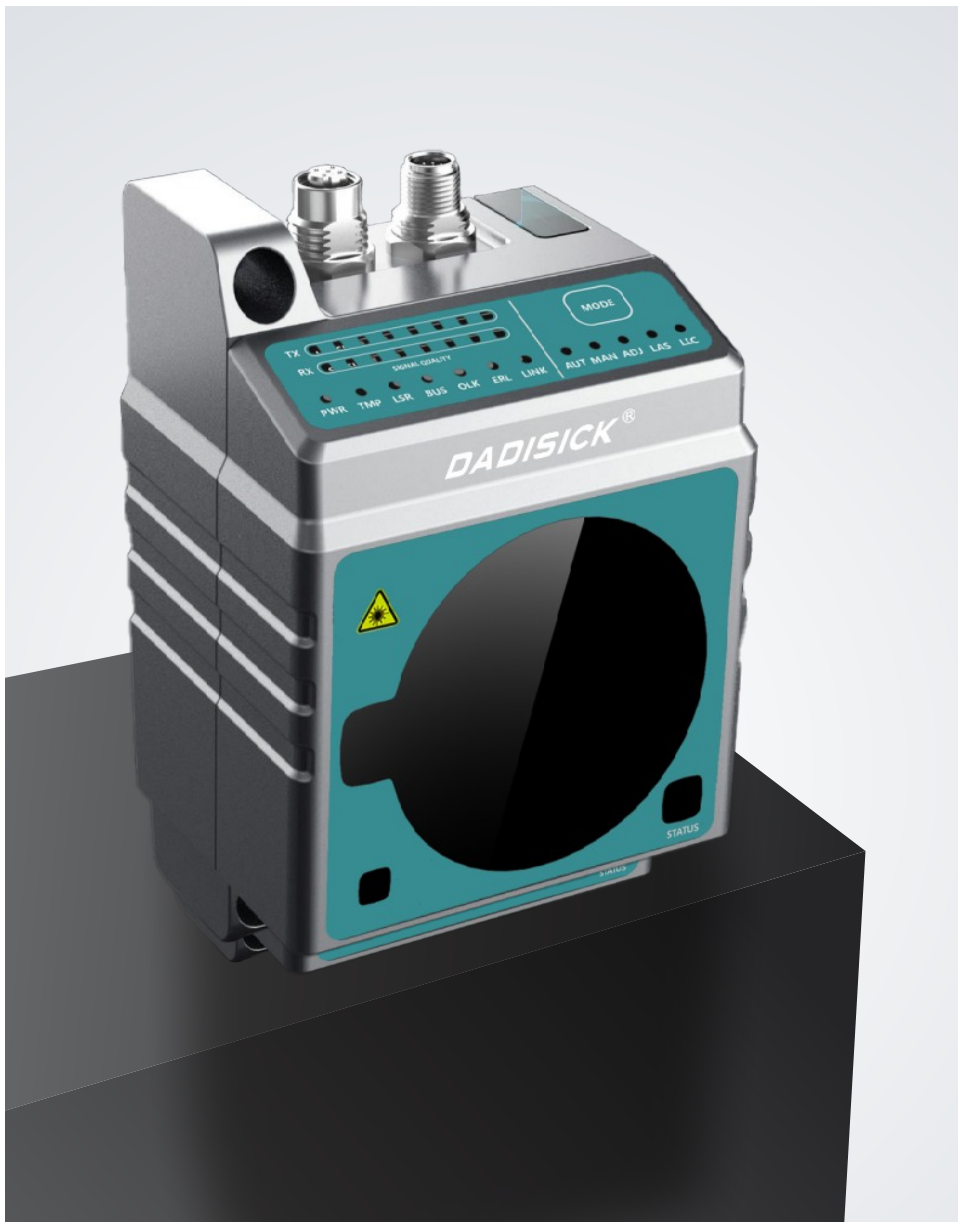

### Contents

- Product Features
- Technical characteristics
- Mechanical Characteristics
- Installation and debugging

## Safety requirements

(To avoid possible danger, please use this product in accordance with regulations)

### General Safety Summary

Please read the following safety precautions carefully to avoid damage to this product or other products connected to this product.

### Use the specified power cord:

Only use the power cord approved in the country where you are located;

### Check the product ratings:

To avoid excessive current shock, please check the ratings and markings marked on the product. Please refer to the product manual for detailed information on the ratings before connecting the product;

### Always use appropriate overvoltage protection:

Make sure that no excessive voltage is connected to the product.

### Ground this product:

Ground the power cable ground wire of this product. To avoid electric shock, before connecting any input or output terminal of this product, please ensure that the ground terminal of the power cable of this product is reliably connected to the protective ground terminal;

### It is strictly forbidden to disassemble the instrument and open the cover without authorization:

Users cannot disassemble the equipment without DADISICK's permission, and it is strictly forbidden to open this product when the equipment is running;

### It is strictly forbidden to scratch the optical mirror with hard objects:

Foreign objects may scratch the optical mirror, and surface scratches will affect the optical transmission characteristics or cause data transmission errors;

### Anti-static protection:

Static electricity may cause damage to the instrument. It should be tested in an anti-static area or under the premise of good grounding as much as possible.

### When you suspect that the product is faulty, it is strictly forbidden to operate:

If you suspect that this product is faulty, please contact DADISICK for inspection. Any maintenance, adjustment or parts replacement must be performed by DADISICK;

**Do not use in corrosive environments:**

To avoid corrosion damage to the equipment, do not use or place the equipment in corrosive environments;

**Do not operate in flammable and explosive environments:**

To avoid equipment damage and personal safety, do not operate or place the instrument in flammable and explosive environments;

**Keep the optical surface of the product clean:**

To avoid dust affecting performance, please keep the optical surface of the product clean;

**Maintain good heat dissipation:**

Please install the device on the metal heat sink surface to maintain good heat dissipation.

**No horizontal direct viewing**

The device has continuous infrared laser emission during operation. To ensure safety, do not look directly at the luminous surface for a long time.

# Contents

<b>1. Product Features</b> .....	05
1.1 Working principle .....	05
1.2 Optical Link Characteristics .....	06
1.3 Main uses of the product .....	06
<b>2. Technical characteristics</b> .....	07
<b>3. Mechanical/Electrical Characteristics</b> .....	08
3.1 Function Display .....	08
3.2 Dimensions and installation .....	09
3.3 Ports .....	10
3.4 Input and output signal connection .....	11
3.4.1 Output signal connection .....	11
3.4.2 Input signal connection .....	12
3.5 Indicator Lights .....	13
<b>4. Installation and debugging</b> .....	14

# 1. Product Introduction



The DK-ST100 series optical data transmission sensor is a high-performance laser data transmission module developed by DADISICK. It uses infrared laser to transmit data, achieving 100M full-duplex and long-distance (80m, 120m and 200m optional) data transmission.

## 1.1 Working Principle

The DK-ST100 series optical data transmission sensor is a data transmission module that uses spatial light as the transmission medium. Its core components include optics, mechanics, circuits, and software. When working, it converts the data stream sent by the host computer into a laser pulse signal and emits a series of laser pulse signals, which propagate through free space to the receiving end. The receiver detects the received optical signal, performs photoelectric conversion, converts the optical signal into an electrical signal data stream, and then uploads it to the host computer at the receiving end, thereby realizing data transmission.

## 1.2 Optical Link Characteristics

The DK-ST100 series optical data transmission sensor uses infrared laser for data transmission, that is, 785nm and 850nm lasers for mutual data exchange. The original spot of the two laser beams is about 5mm, and the beam divergence angle is  $1^\circ$ , and the matching receiving field of view is  $1.5^\circ$ .

## 1.3 Main Applications of Products

The DK-ST100 series optical data transmission sensors use light for data transmission. There are no cables for data transmission. Therefore, this device can be used in places where transmission cables are inconvenient to use. The main scope includes: smart warehousing, overhead cranes, reciprocating transportation systems, port automation, stackers, rail vehicles, etc.



Smart warehousing



Lifting or hoisting devices



Automated parking systems



Port automation

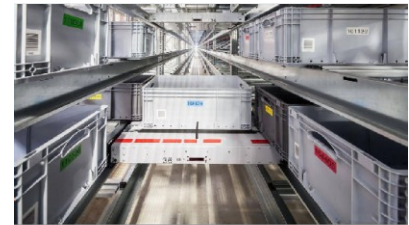

Reciprocating transport systems

## 2. Technical characteristics

### 2.1 Technical characteristics

<b>Basic information</b>			
Product name	Optical data transmission module		
Transmitter model	<b>DK-ST100-80E3</b>	<b>DK-ST100-120E3</b>	<b>DK-ST100-200E3</b>
Receiver model	<b>DK-ST100-80E4</b>	<b>DK-ST100-120E4</b>	<b>DK-ST100-200E4</b>
<b>Performance parameters</b>			
Effective transmission distance	80m	120m	200m
Communication rate	100Mbit/s		
Communication light divergence angle	1°		
Communication light receiving angle	1.5°		
<b>Mechanical / optical properties</b>			
Power supply voltage	DC10V-30V		
Working current	3W (MAX)		
Laser source	Calibration light: red light Communication light source wavelength: E3 785nm/E4 850nm		
Dimensions	100*84*140 (mm)		
Protection level	IP65		
<b>Other</b>			
Data transmission interface	Ethernet		
Communication protocol	Unlimited		
Environmental humidity	<80% RH		
Working temperature	-10°C~55°C(indoor use)		
Storage temperature	-20°C~70°C		
Ambient light	<80000 lx		
Protection level	IP65		

### 3. Mechanical / Electrical Characteristics

#### 3.1 Functional Demonstration

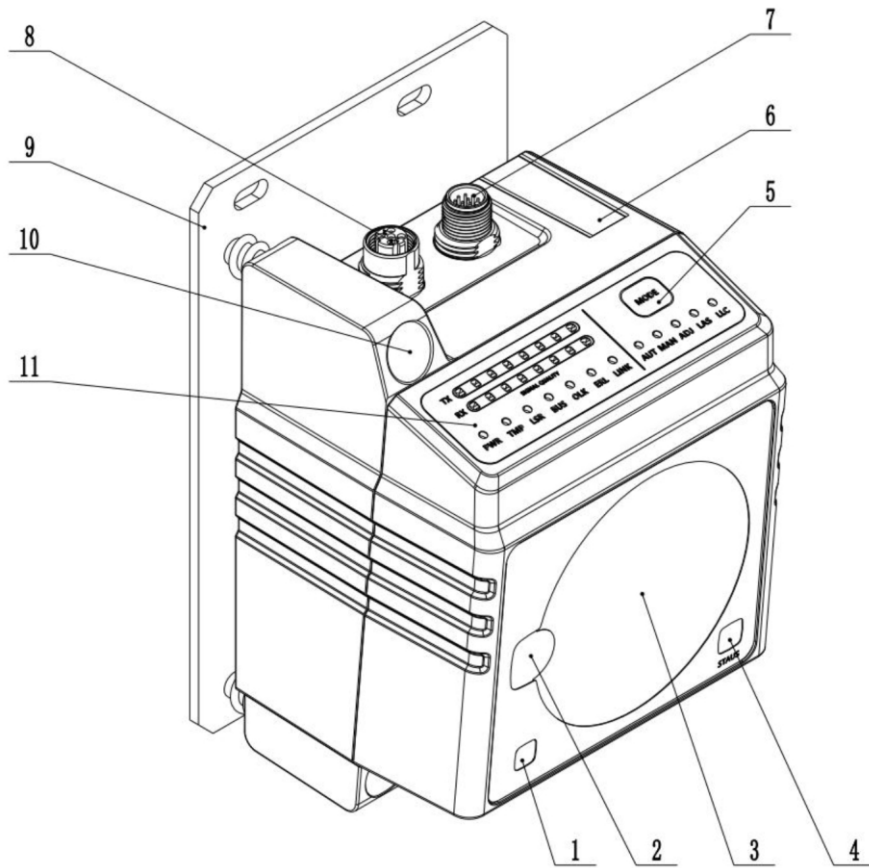

1	Calibration light source port
2	Send window
3	Receive window
4	Sensor status light
5	Function mode button
6	Level indicator tube
7	Ethernet port
8	Power and IO signal port
9	Fixed mounting plate
10	Adjustment fixing hole
11	LED status display area

## 3.2 Dimensions and installation

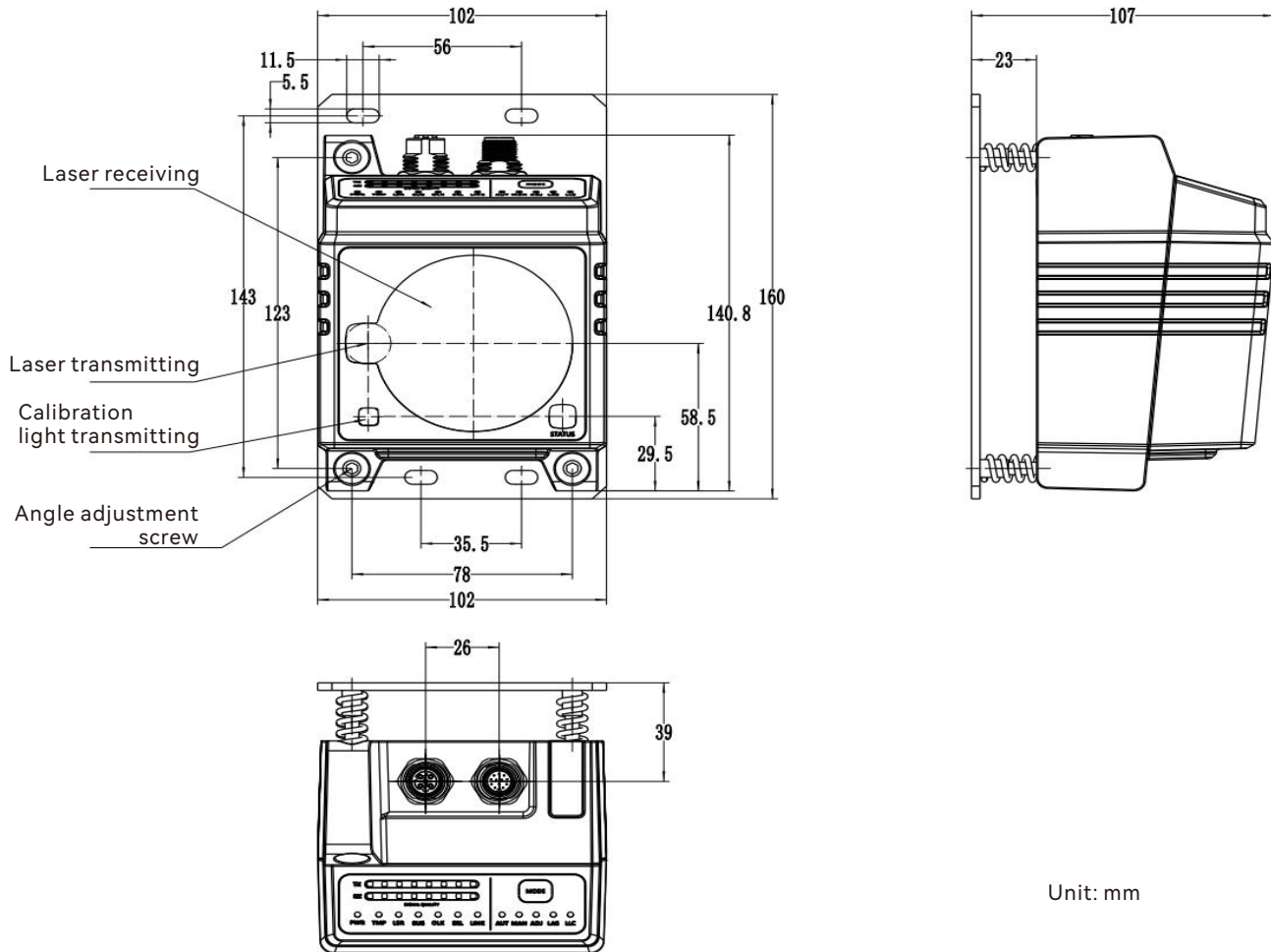

### 3.3 Ports

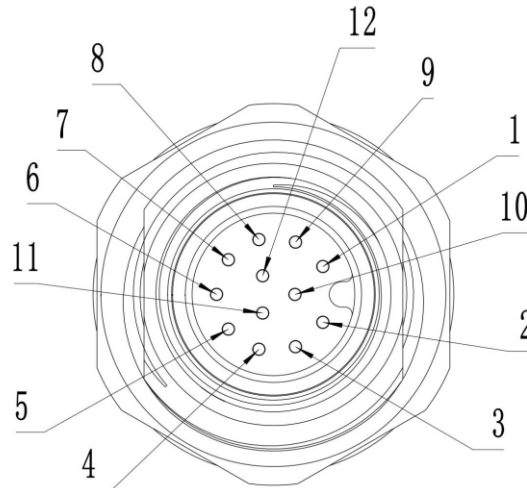

Connector model: M12 aviation plug, D code, 12Pin, male

Number	Symbol	Attribute	Color	Function
Pin1	+VIN	Enter	blue	Input power positive pole DC10-30V
Pin2	X0+	Enter	brown	Control communication: OFF: Enable communication ON: Disable communication
Pin3	Reserve		orange	Reserve
Pin4	Reserve	Enter	grey	Reserve
Pin5	-VIN	Enter	black	Negative power input
Pin6	Reserve	Output	yellow	Reserve
Pin7	Y0-	Output	pink	IO output common terminal
Pin8	Y0+	Output	green	Received signal strength status indicator
Pin9	X0-	Enter	white	IO output common terminal
Pin10	Reserve		purple	Reserve
Pin11	Reserve		red-blue	Reserve
Pin12	Reserve		grey-pink	Reserve

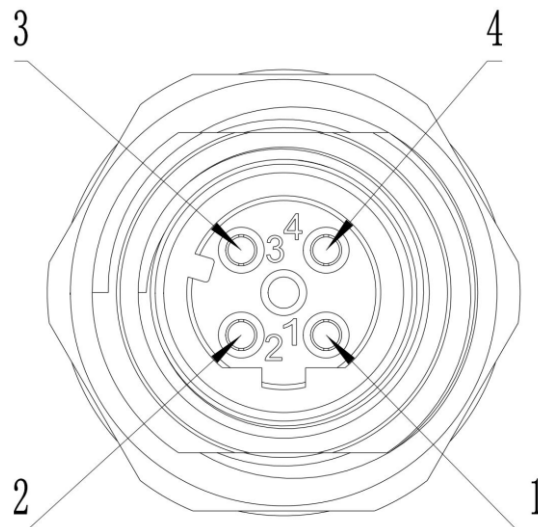

Connector model: M12 aviation plug, D code, 12Pin, female

Pin1	Tx+
Pin2	Rx+
Pin3	Tx-
Pin4	Rx-

### 3.4 Input and output signal connection

#### 3.4.1 Output signal connection

Output signal function definition

Port	Function	Output logic
Y0	Received signal strength indication	ON: signal strength is poor. OFF: signal strength is normal;

The maximum load capacity of the output port is 100mA, and the maximum external power supply is DC24V±10%.

NPN wiring diagram:

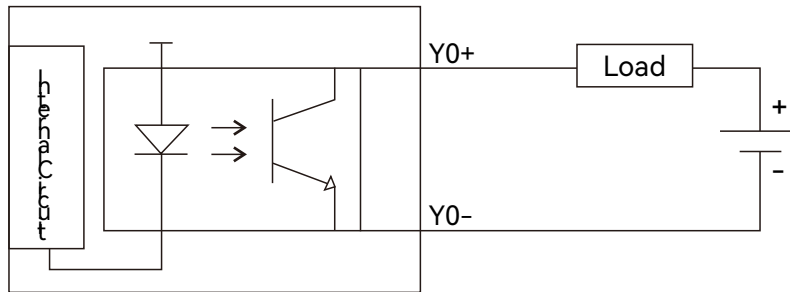

PNP wiring diagram:

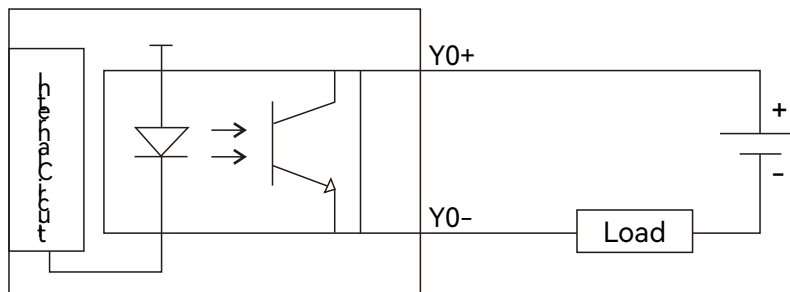

### 3.4.2 Input signal connection

Port	Function	Control logic
X0	Control the working state of the optical module	ON: The device is in standby state OFF: The device is in working state

Signal wiring diagram, the external power supply of the input port is DC24V±10%.

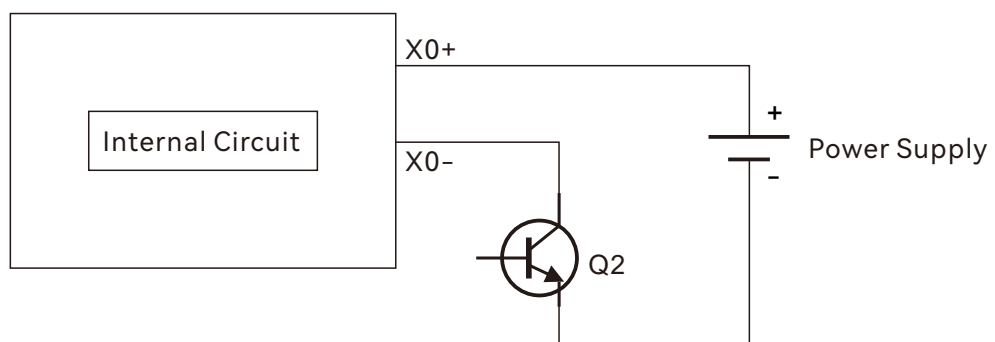

Note: The input and output ports cannot be short-circuited, the maximum input voltage is 24V±10%, and a load exceeding 100mA cannot be connected, otherwise the port will be damaged.

### 3.5 Indicator Lights

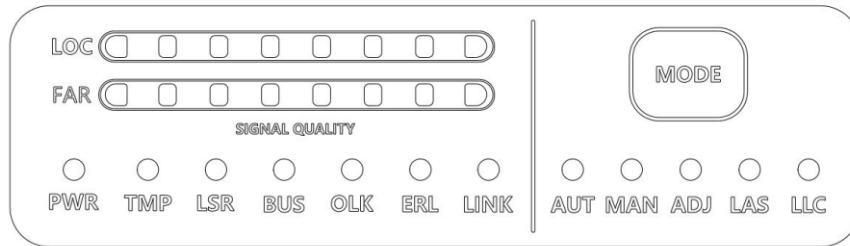

Annotation	Display	Operation Instructions
AUT	Green	Always on: normal working mode; Off: power off or calibration mode;
MAN	Green	Always on: calibration mode; Off: none
ADJ	Not used	
LAS	Not used	
LLC	Not used	
PWR	Red/Green	Off: no power supply voltage; Green-on: normal power supply; Red-on: device abnormality;
TMP	Red	Off: The device is operating at normal temperature; Red-Steady on: The device is operating at a temperature exceeding the operating temperature;
LSR	Not used	
BUS	Not used	
OLK	Green	Off: no light signal; Green-steady on: the light signal link is normal;
ERL	Red	Off: The device is normal; Red-on: The device is abnormal;
LINK	Green	Off: The network connection is not successful; Green-steady on: The network cable connection is normal;
LOC	2 Red 2 Orange 4 Green	LOC represents the signal strength of the unit. If only the red light is on, the signal is weak; if the red and orange lights are on, the signal strength is medium; if all the red, orange and green lights are on, the signal strength is good;
FAR	2 Red 2 Orange 4 Green	FAR stands for the receiving signal strength of the other machine, which is effective only in calibration mode; red light means weak signal, red and orange light means medium signal, red, orange and green light means good signal;
MODE		Switch mode: turn on and off the calibration mode and calibration light source;

## 4. Installation and debugging

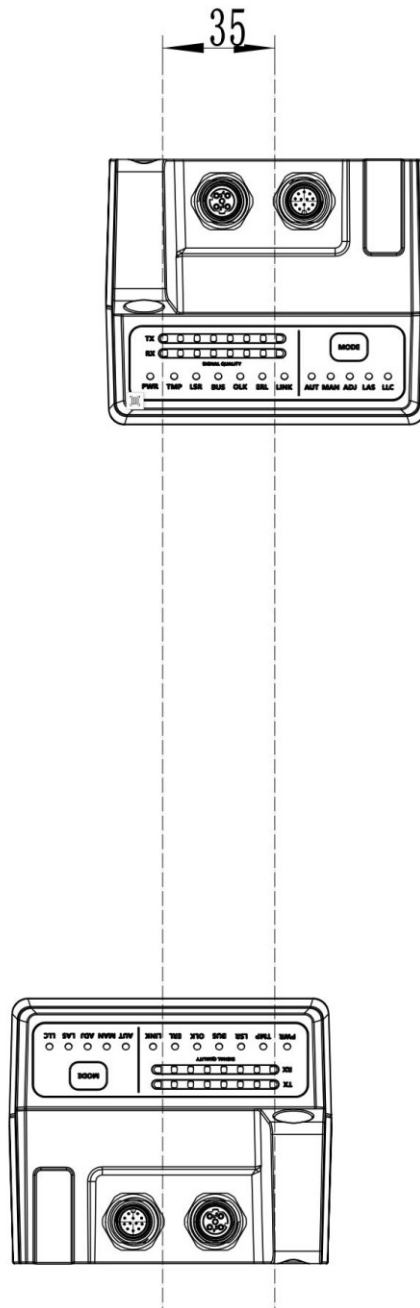

During installation, it needs to be offset 35mm horizontally to ensure that the sending center of the transmitter is aligned with the receiving center;

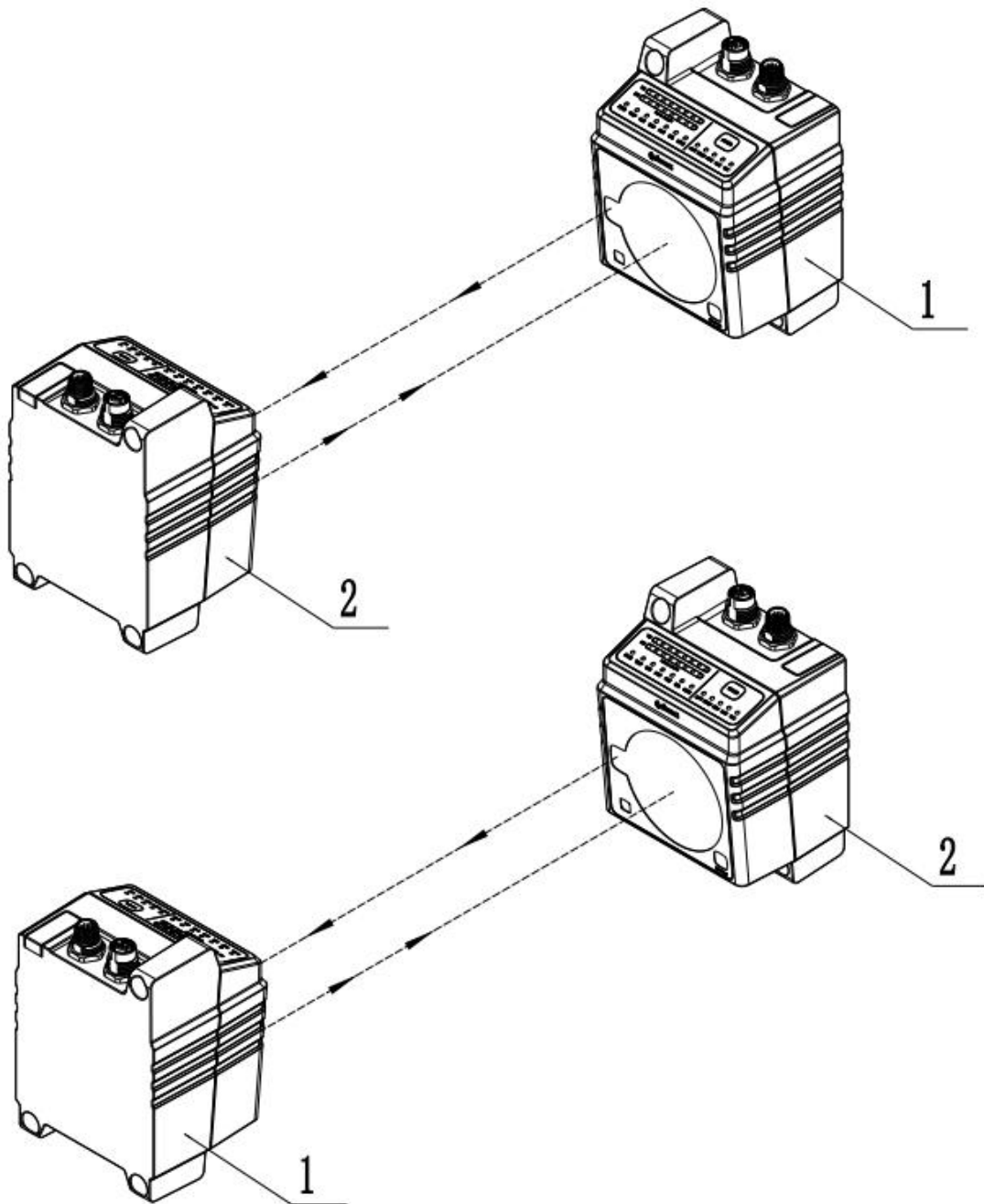

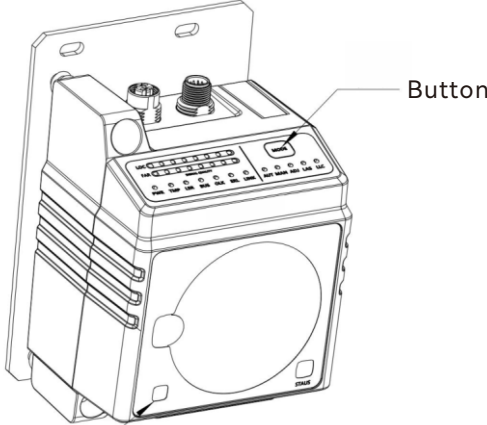
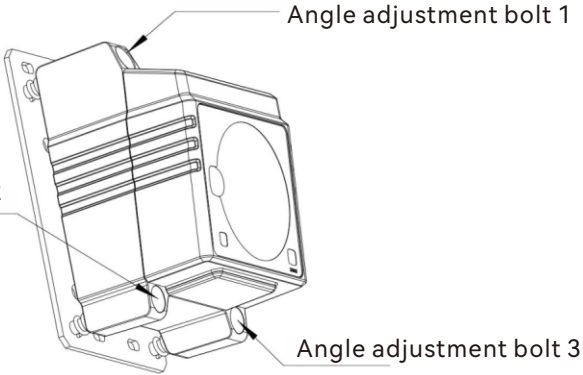
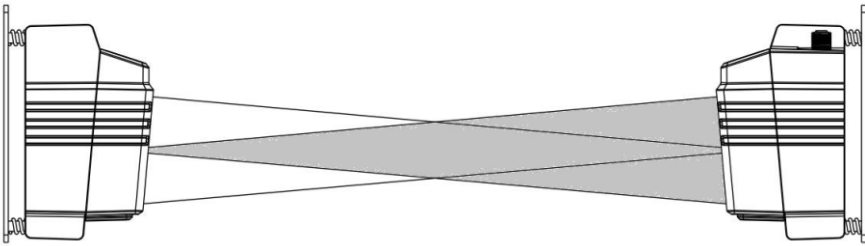
<b>Installation confirmation</b>	
<b>Initial position</b>	
	 <p>Button</p> <p>Calibrate laser</p> <p>Start the calibration mode. Both devices need to be set to calibration mode.</p>
	 <p>Angle adjustment bolt 1</p> <p>Angle adjustment bolt 2</p> <p>Angle adjustment bolt 3</p> <p>Use a 4mm hexagonal wrench to adjust the module angle;</p>
	 <p>The calibration light source can be aligned with the sending window of the opposite module;</p>
	<p>Confirm the communication status at a close distance of 0.5 meters;</p>

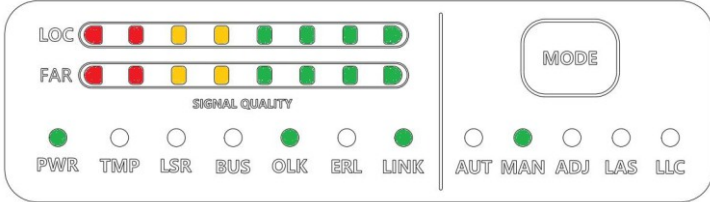
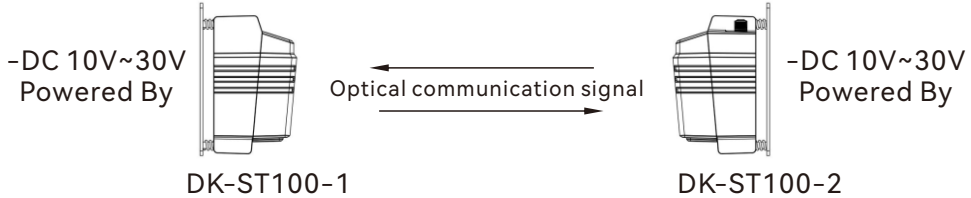
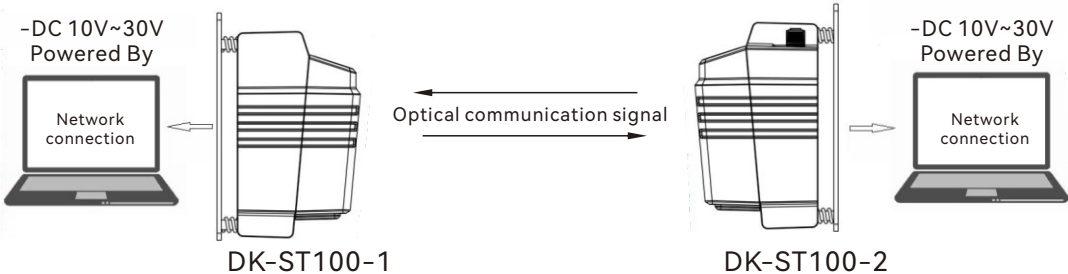
	 <p>Confirm the above light status; Make sure the LOC and FAR signal lights are all on;</p>
	 <p>1) Gradually increase the distance until the signal begins to weaken to the orange area, and then adjust the installation angle;</p> <p>2) The goal of adjusting the angle is that the LOC and FAR signals need to reach the maximum signal front angle at the current distance, and it does not necessarily require full grid;</p>
<b>Debugging confirmation</b>	
<p>After completing the installation and docking, perform a network test and link supported Ethernet devices according to the following diagram;</p>  <p>After the installation is complete, Device 1 and Device 2 can communicate directly via Ethernet;</p>	