

USER MANUAL

LASER OBSTACLE SENSOR DK-LD-10H series



Thank you for using our products.

This manual explains the usage and safety precautions of the product.

*Read this manual carefully and pay attention to safety during use.





*Keep this manual in a suitable place for easy reference.

CONTENTS





1 Safety Matters	3
2 Function Introduction	4
3 Prepare	7
4 Install	8
5 Connection	14
6 Communication Protocol	19
7 Troubleshooting	38
8 After-sales information	39

1 Safety Matters





1.1 Applicable environment notes

-  Visible particles in steam, smoke, dust and air can cause the sensor to misjudge or even fail to work.
-  Regularly arrange for qualified technicians to check whether the sensor is connected and installed correctly.
-  The maximum service life of the sensor is 10 years, after which it must be replaced, otherwise it may not meet the required performance requirements.
-  The sensor should be checked and cleaned regularly.
-  This product is only allowed to be used within the specified limits and the specified technical parameters and operating conditions at any time.

1.2 Notes on wiring environment

-  Do not connect the power supply in reverse or connect it to a voltage higher than the specified maximum working voltage, otherwise the sensor will be damaged.
-  If the power supply is connected to a voltage lower than the specified minimum working voltage, the sensor will not work or work abnormally;
-  Please follow the instructions in the manual for wiring, otherwise the sensor may not be able to detect the input signal correctly;
-  Do not connect the output signal end to a device that exceeds the sensor load capacity, otherwise it will cause the sensor to malfunction.

1.3 Notes on debugging environment

-  Only qualified authorized personnel are allowed to connect, install, debug and set up laser sensors;
-  Confirm that the peripheral equipment associated with the sensor is in a reliable stopped state;
-  Confirm that the debugger himself is in a safe position;
-  Confirm that other people or objects are out of the range of the device.

2 Function Introduction

2.1 Main Features

Basic characteristics		
Product model	DK-LD-10HN	DK-LD-10HP
Working area	0.05-6m(10%)	0.05-10m(90%)
Detection range	270°	
Laser light source	Infrared laser (905nm)	
Performance		
Response time	Typical Value 50ms	
Basic error	40mm	
Statistical error	30mm	
Number of channels	64 (each channel contains 3 detection areas)	
Detection output delay	Settable within the range of 0ms-500ms	
Detection hold delay	Settable within the range of 0ms-500ms	
Detection size filtering angle	Settable within the range of 0.5°-5°	
Interface		
Configuration port	1 (Micro-UsB)	
RS232	1	
RS485	1	
CAN BUS	1	
Switching output	1 (1 detection signal, 1 fault signal), single load capacity of 100m	
Aindicator light	4 (3 detection signal lights, 1 status light)	
Electrical performance		
Working voltage	DC18-32V	
Current consumption	60mA typical (without output load)	
Working environment		
Object reflectivity	5%-1000%	
Working environment	-10°C-50°C	
Ambient light intensity	< 15000lx	

2.2 Function

LiDAR operates based on the principle of time-of-flight (TOF) measurement. Under a very high synchronous clock, the laser is emitted at uniform time intervals. When the laser beam encounters an object, it is reflected back. After the scanning sensor receives the reflected beam, the distance from the laser sensor to the object is calculated by the time difference Δt between emission and reception.

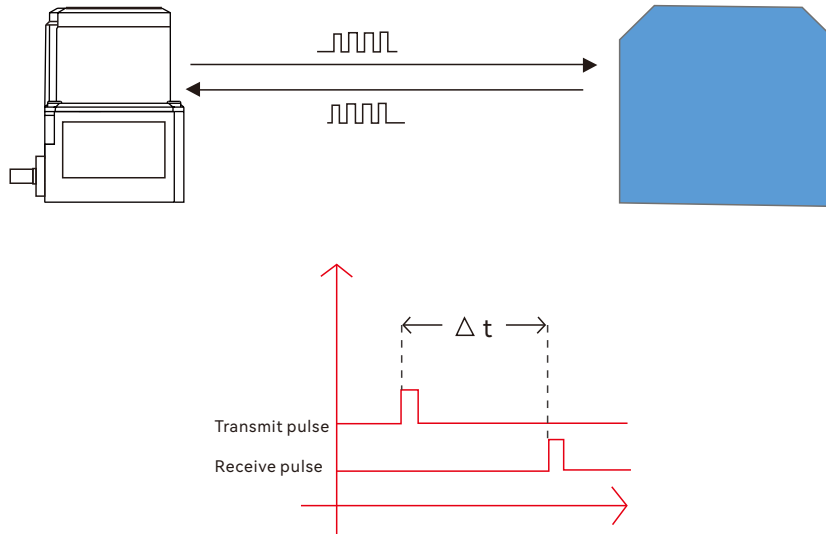

$$\Delta t = \frac{t}{2}$$

$$S = v * \Delta t$$

s : measured distance
 v : laser flight speed
 Δt : time difference
 t : laser flight time (round trip)

The laser beam is used to perform a two-dimensional scan of the surroundings to obtain an environmental contour graphic. The protection area range is established through software configuration. Once an object is in the set area, the sensor will have a corresponding output port signal output. After the upper computer obtains the signal, it will make further judgments and processing.

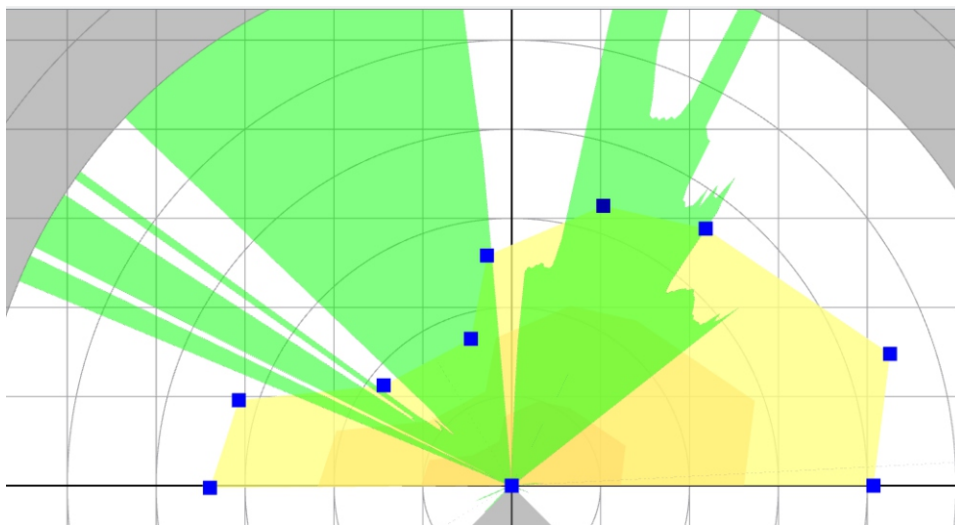

There are 64 channels in the sensor, and up to 64 different sensing ranges can be set. Meet the detection needs in different occasions. The following figure shows the AGV application process.

When the AGV runs to the line A position, the sensing range set by channel 1 is used for detection;

When the AGV runs to the line B position, due to the change of the external space, the original channel 1 sensing range cannot pass, so it switches to channel 2 with a smaller sensing range setting to run through.

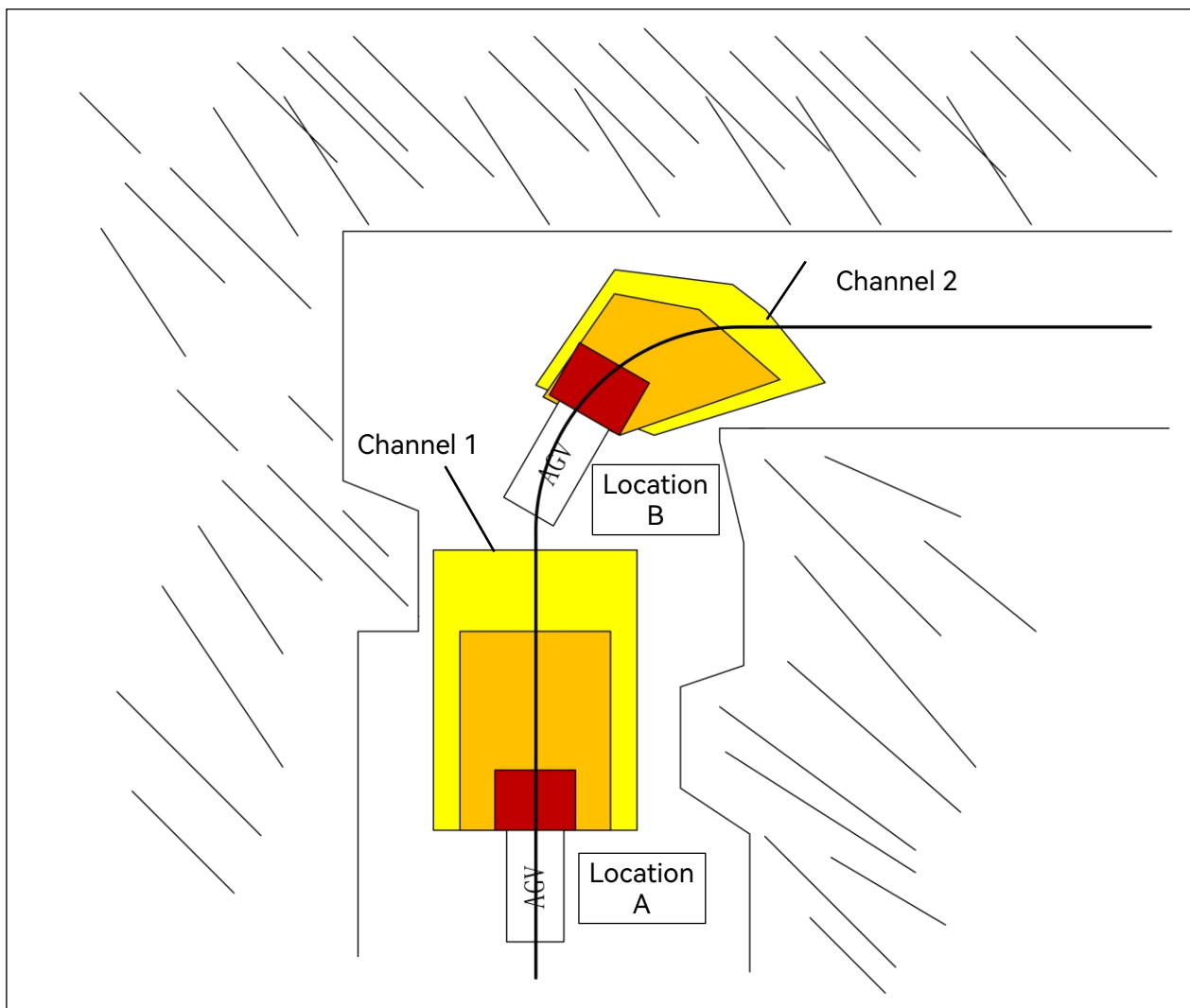

3 Prepare

3.1 Packing List

Please confirm whether the product name and model on the external label of the product packaging box are consistent with what you purchased;

Please confirm the product name and model through the external label of the product;

Please confirm whether the following items are complete after unpacking. If not, please contact the supplier;

Laser Obstacle Sensor	DK-LD-10HN	1
Configuration software	Configuration software V1.3 or above	1

3.2 Debugging Tools

Connection	USB-Micro USB cable	1
Computer	Running Windows XP and above	1

3.3 Usage steps

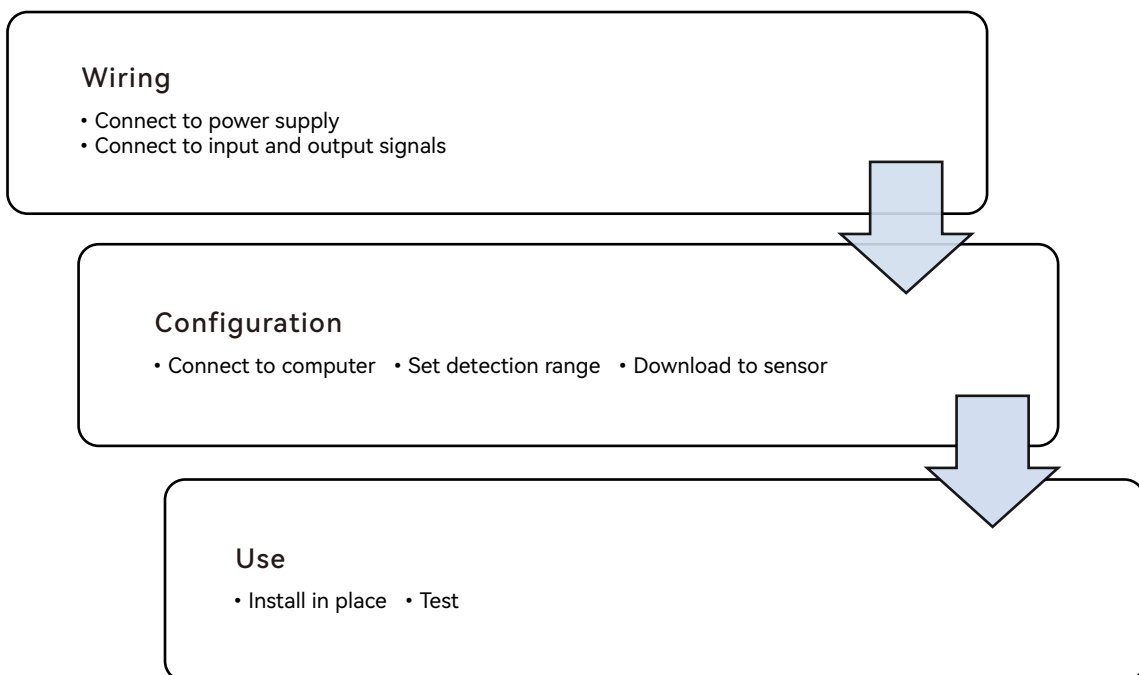

4 Install

4.1 Size parameters

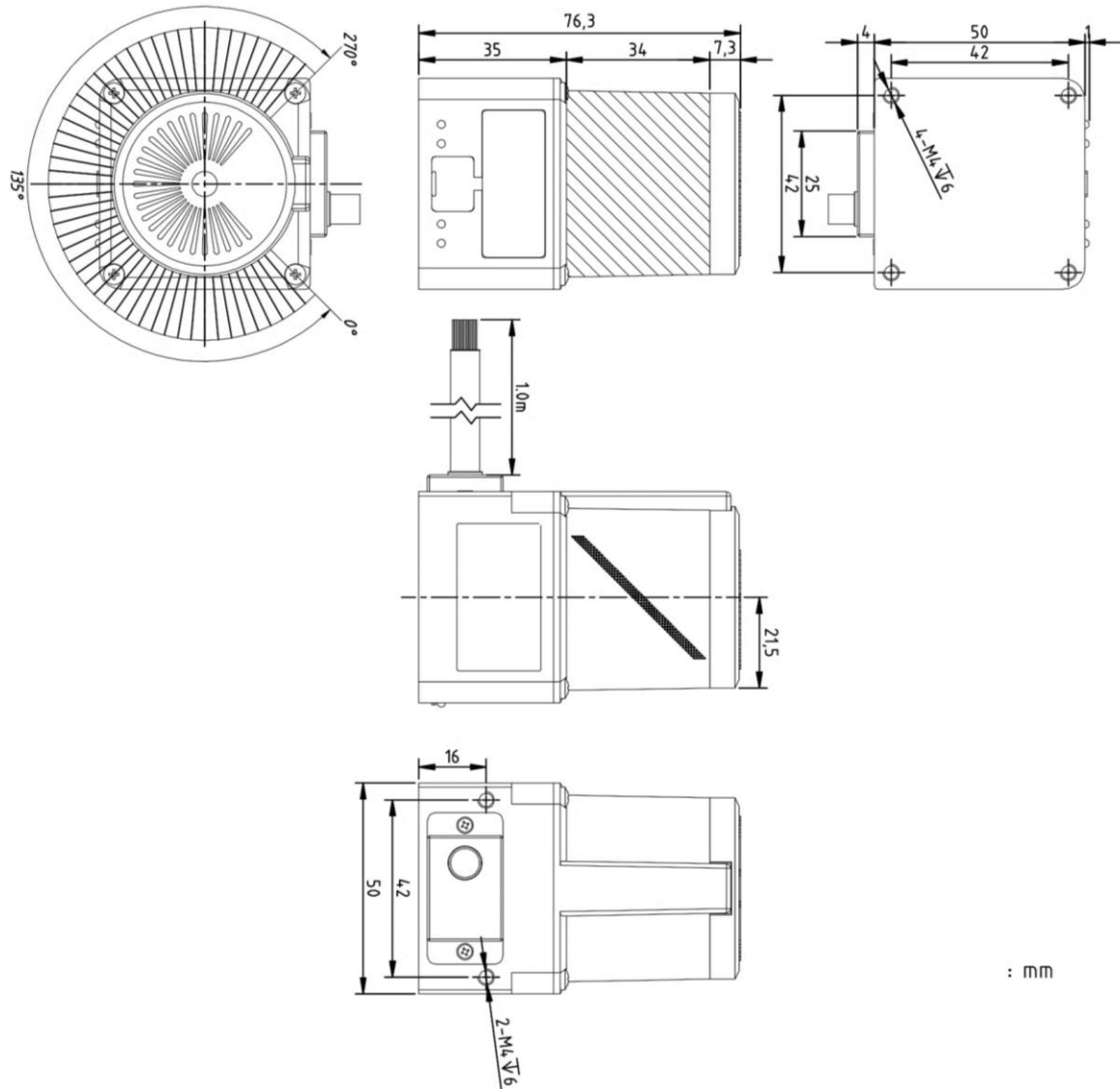

4.2 Detection Capabilities

Detection range

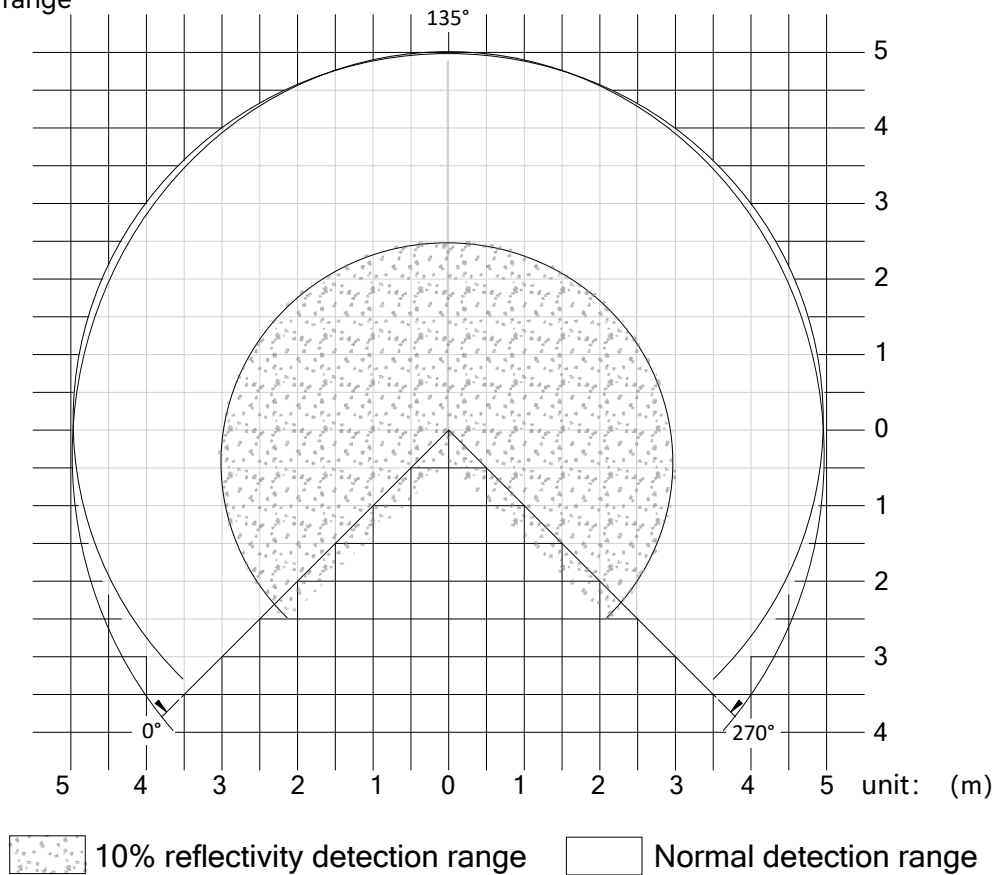

Detecting the size of an object

The laser scanning sensor has a rotating mirror, and the laser beam pulses are continuously emitted at an angle of 0.5 degrees with the rotating mirror, so that a sector-shaped area can be scanned. The emitted laser beam covers a sector surface, so that objects can be identified in an area of up to 270°.

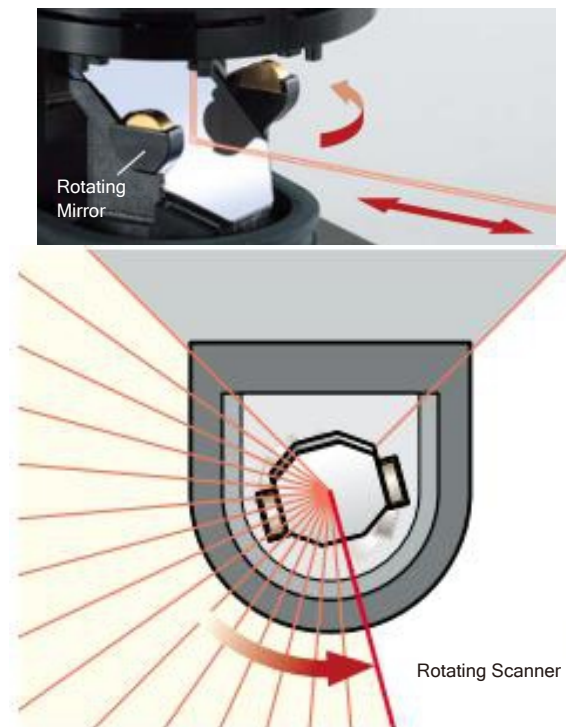

- ① The angular resolution is 0.5 degrees.
- ② The minimum resolution D of the detected object, in mm

Resolution D Calculation Formula

$$\text{Resolution } D = 2\pi L \frac{0.5}{360}$$

L: The distance from any point to the laser sensor, which is also the distance from the measured point to the laser sensor.

For example, when the set length L is 1000mm, the minimum resolution of the object that can be detected is 8.72mm.

Since the laser scanning sensor uses the active scanning principle, no external receiver and reflector are required. This can bring the following advantages:

- ※ Less installation work
- ※ The monitoring area can be easily adjusted to the area of the machine that needs to be protected
- ※ Compared with contact sensors (contact anti-collision), non-contact scanning is almost wear-free

4.3 Installation Requirements

The laser scanning sensor comes with a cable, and a space for the cable outlet needs to be reserved to avoid excessive bending of the cable. The Micro USB jack and indicator light should be reserved in front of the laser scanning sensor base to facilitate connection debugging and observation of the sensor status.

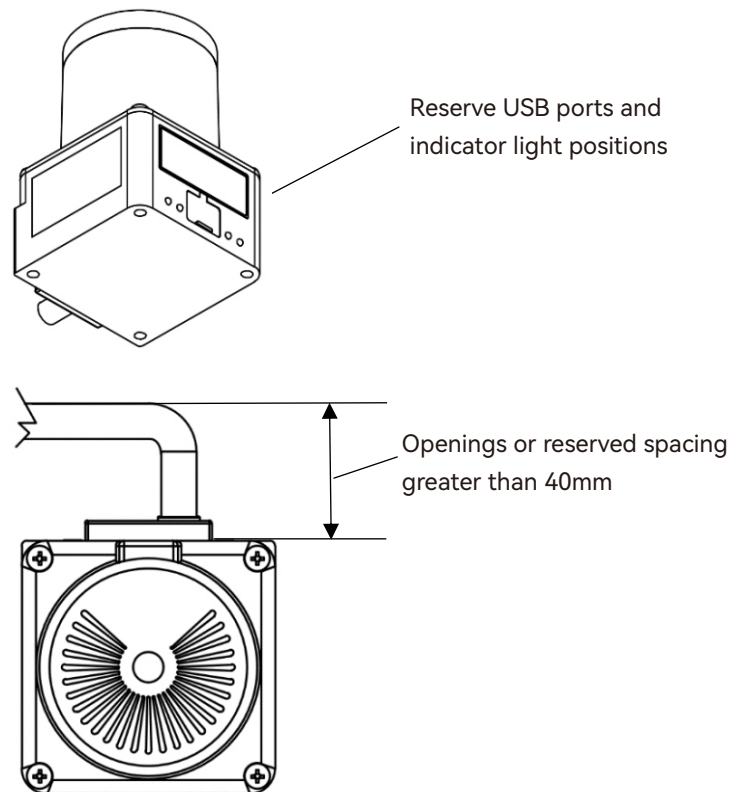

1. When two or more sensors are staggered and installed, it is recommended that the inclination angle be more than 3° to prevent mutual interference.

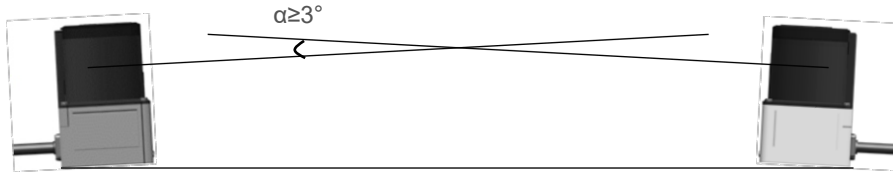

2. When two or more sensors are cross-mounted, it is recommended that the inclination angle be more than 3° to prevent mutual interference.

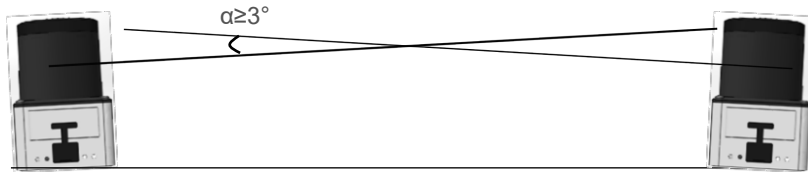

3. When two or more sensors are cross-installed, it is recommended to stagger them by more than 40mm to prevent mutual interference.

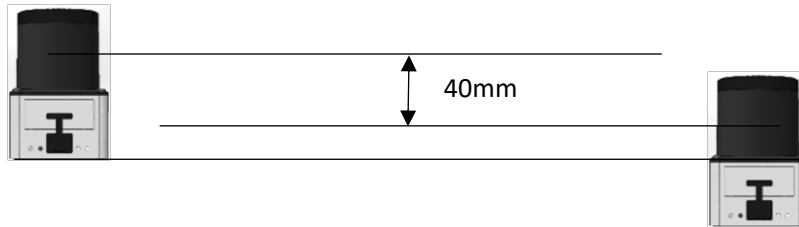

Since the sensor spot emits in a conical divergent shape, it is recommended that the laser scanning sensor be installed at a height of $\geq 200\text{mm}$ from the ground. If the installation height is $< 200\text{mm}$ from the ground, please tilt the laser scanning sensor upward by $1\sim 3^\circ$.

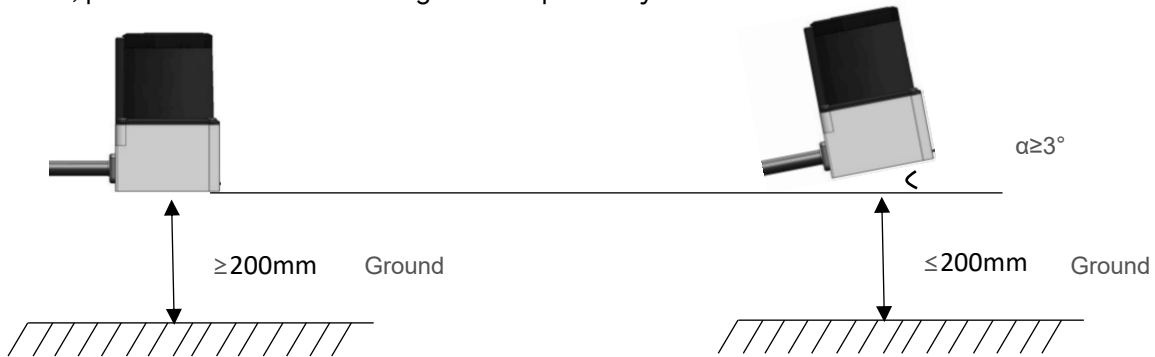

Front installation diagram

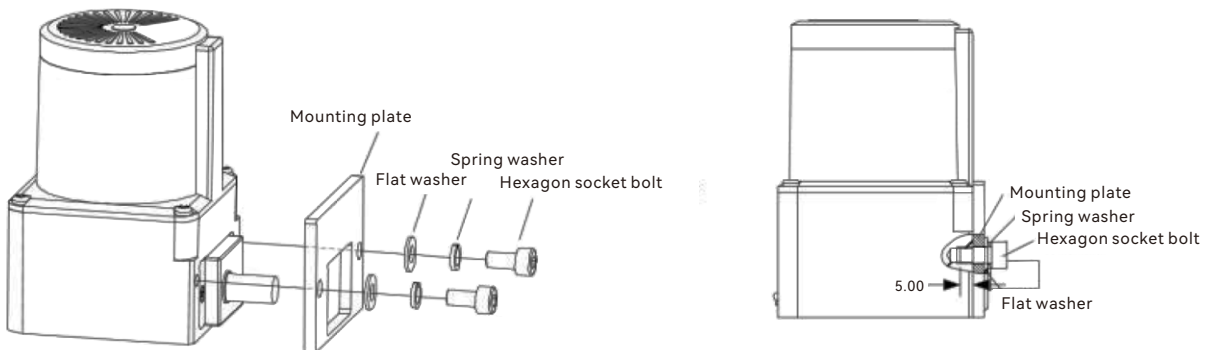

Bottom installation diagram

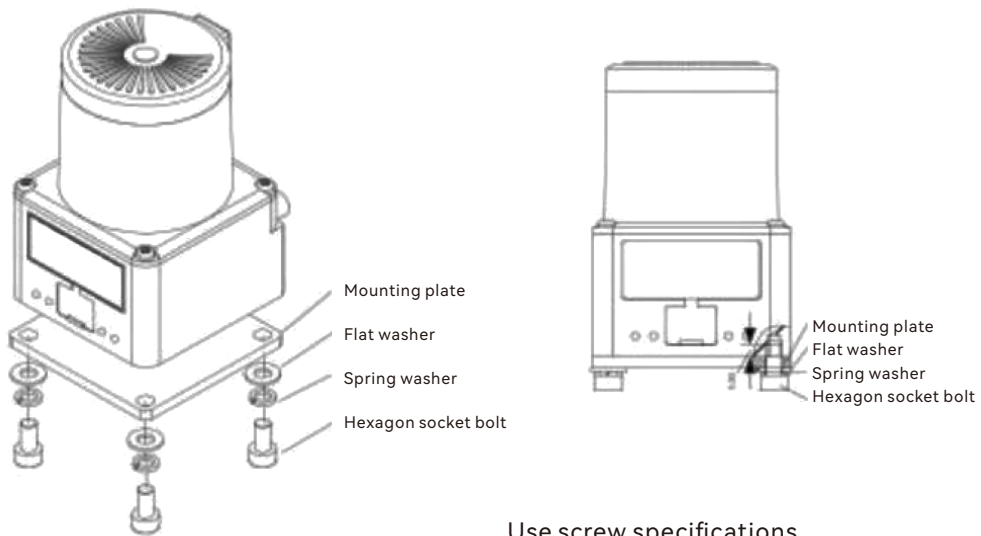

Use screw specifications

Screw specifications	Tightening torque
M4*10mm	0.1N.M

4.4 Port

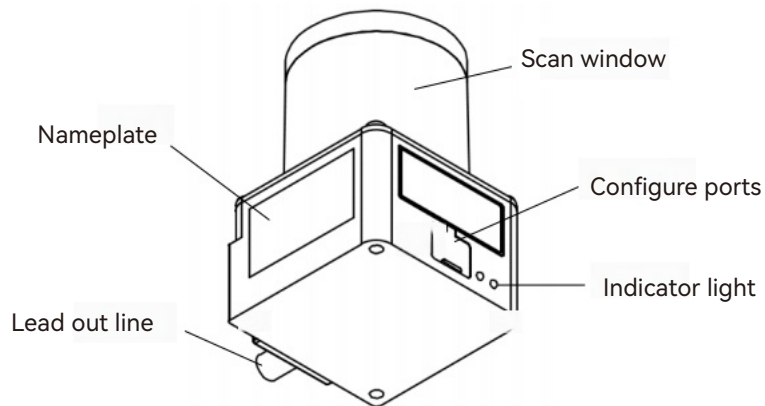

4.5 LED Status Display

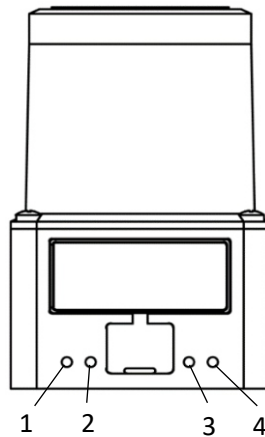

NO	Name	Functional Description
1	Power indicator	When the laser sensor receives the correct power supply, it lights up as a green indicator light. When an internal fault occurs, the power indicator light flashes
2	OUT3 indicator	If intrusion is detected within the setting range of laser sensor OUT3, the red indicator light will light up. If intrusion is not detected, it will not light up.
3	OUT2 indicator	If intrusion is detected within the setting range of laser sensor OUT2, the yellow indicator light will light up. If intrusion is not detected, it will not light up.
4	OUT1 indicator	If intrusion is detected within the setting range of laser sensor OUT1, the orange indicator light will light up. If intrusion is not detected, it will not light up.

5 Connection

5.1 Line Definition

The sensor cable leads to 14 core wires, and the wire color definition corresponds to the following table

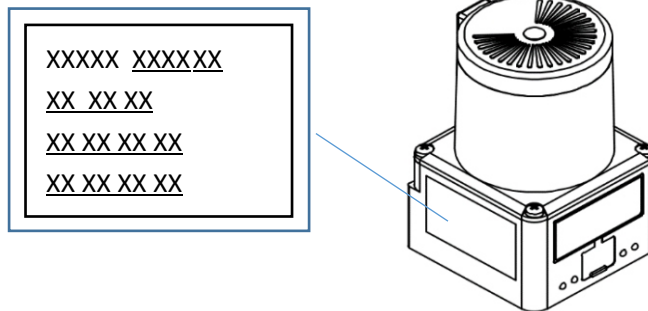

Colors	Model Type	Signal	Function Description
Brown	Power supply	DC 24V	Positive pole of power supply 18-32V
Blue	Power supply	DC0V	Negative pole of power supply
White Brown	RS232	RX	RS232 RX port
Orange		TX	RS232-TX port
Yellow		GND	RS232-GND port
Green	RS485	A	RS485 port A
Purple		B	RS485 port B
Gray		GND	RS485 GND port
White	CAN BUS	CAN-H	CAN H position
White Green		CAN-L	CAN L position
White Blue		CAN-D	CAN-GND
Black	Output	OCOM	Output public end
Red		OUT3	OUT3 output port
White Red		Error OUT	Port action when sensor failure occurs

5.2 Power Connection

Power supply: DC24V \pm 10%; In the AGV system or other power equipment networks, it is necessary to add a DC24V voltage regulator to ensure that power interference does not affect the normal operation of sensors.

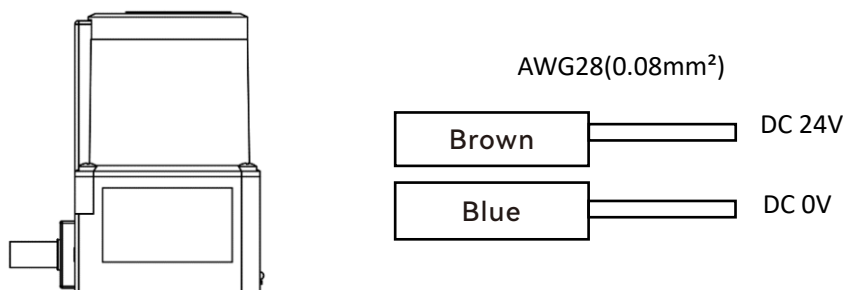

Rs485 Connection

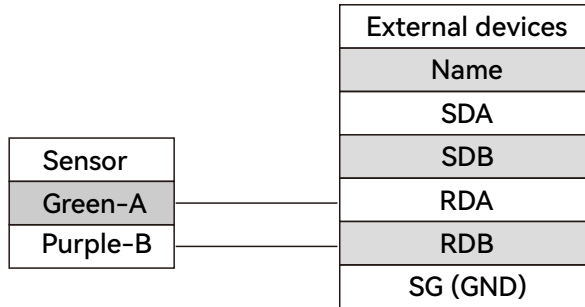

CAN BUS Connection

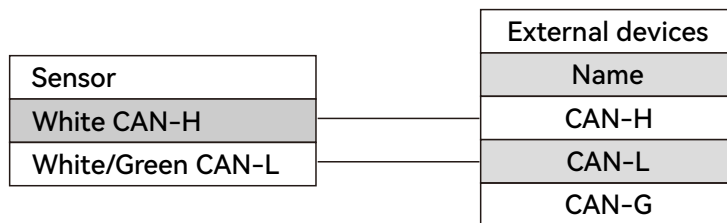

Cable requirements:

- 1) CAN-H and CAN-L cables need to use twisted pair and shielded

5.4 Output signal connection

Output signal usage function

OUT3: used for near-end emergency stop;

ERROR: signal output of sensor error state, no output in normal state, output signal in fault state;

The output is an open collector (NPN) signal, using optocoupler isolation output, the voltage is 0V-1.5V when there is a signal, and the maximum load capacity of the output port is 100mA.

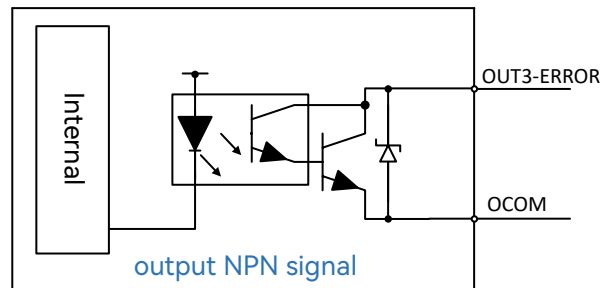

The output ports are all NPN outputs. Please refer to the following figure for the output schematic:

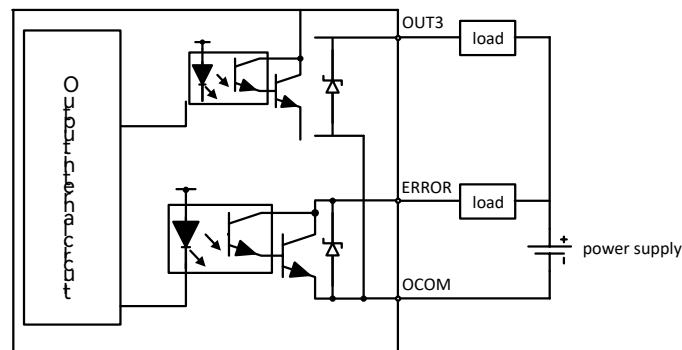

The sensor output ports correspond to the graphics drawn in the configuration software.

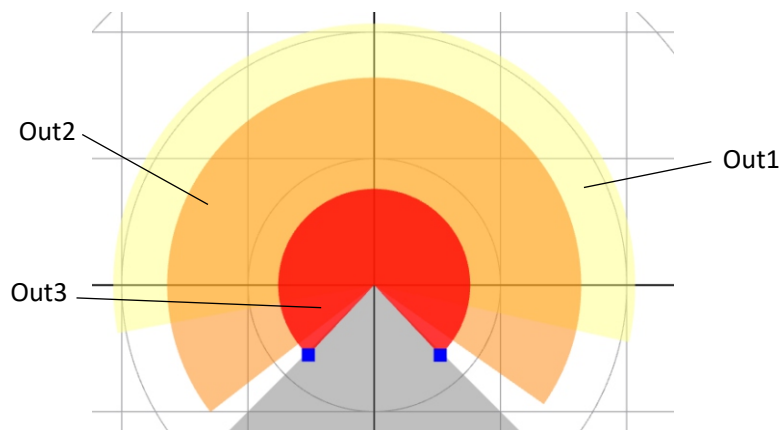

Note: There will be detection output only when there is a drawing graph for the corresponding output;

5.5 Configuring Connections

Use the Micro-USB port cable to connect the computer to the sensor

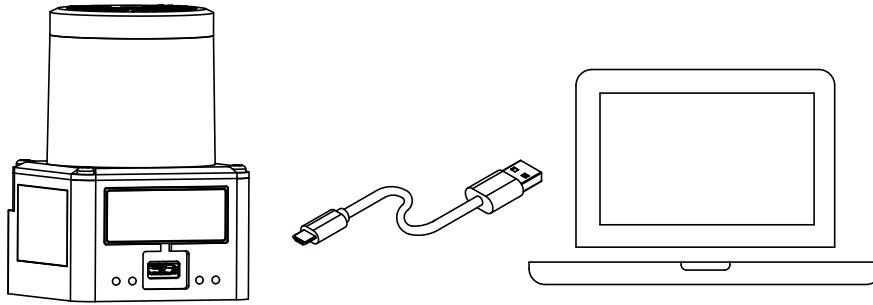

Notice | Connecting the data cable to the sensor end in the wrong direction will damage the sensor port. You must use a cable that can transmit data. The charging cable cannot be connected successfully.

NPN Wiring Diagram

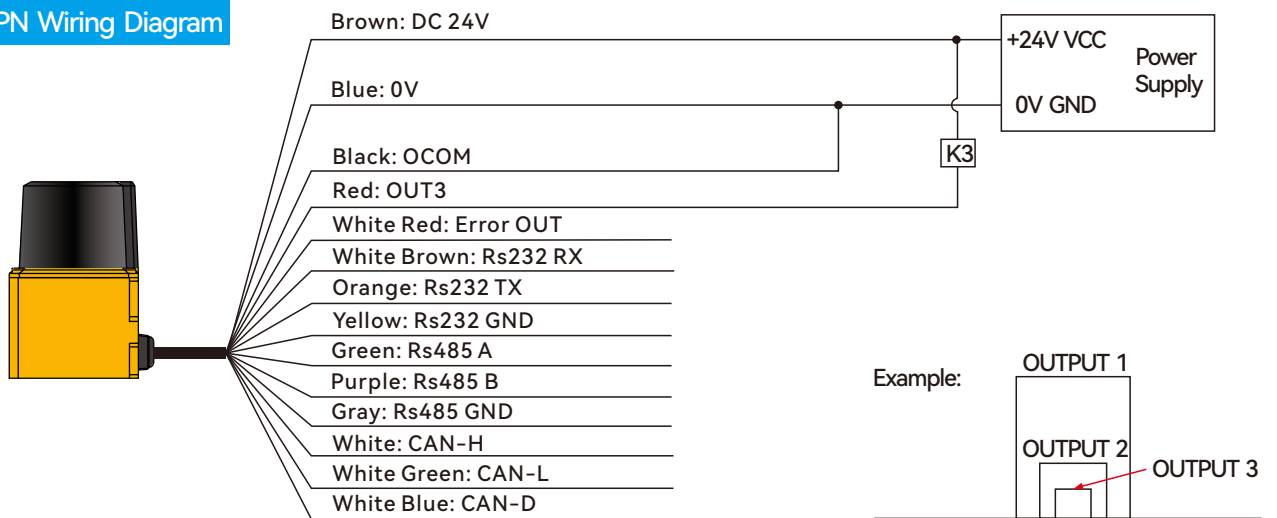

PNP Wiring Diagram

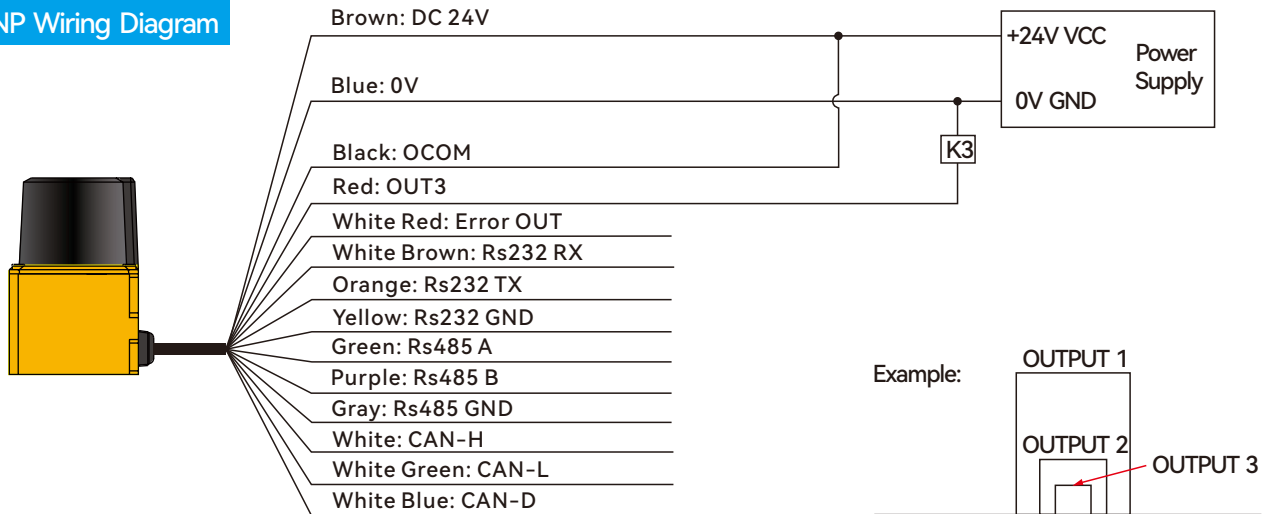

6 Communication Protocol

The sensor and the host computer use a communication connection method that supports RS232, RS485 and CAN BUS. The sensor can work in three data output states, and the host computer obtains information according to demand.

Term explanation

Host computer: client device, sensor direct control end. Generally, it is PLC, single-chip microcomputer or industrial computer equipment, etc.;

· Channel designation

In the current state, the current channel of the sensor is controlled by the host computer, and the sensor returns the current detection area status.

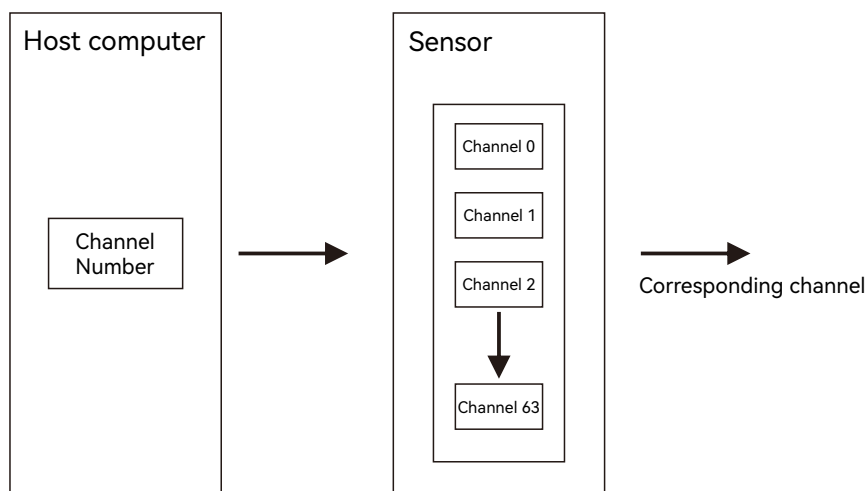

· Intelligent channel selection

In the current state, the host computer provides channel group information, speed and angle data, and the sensor automatically selects the channel for the preset parameters.

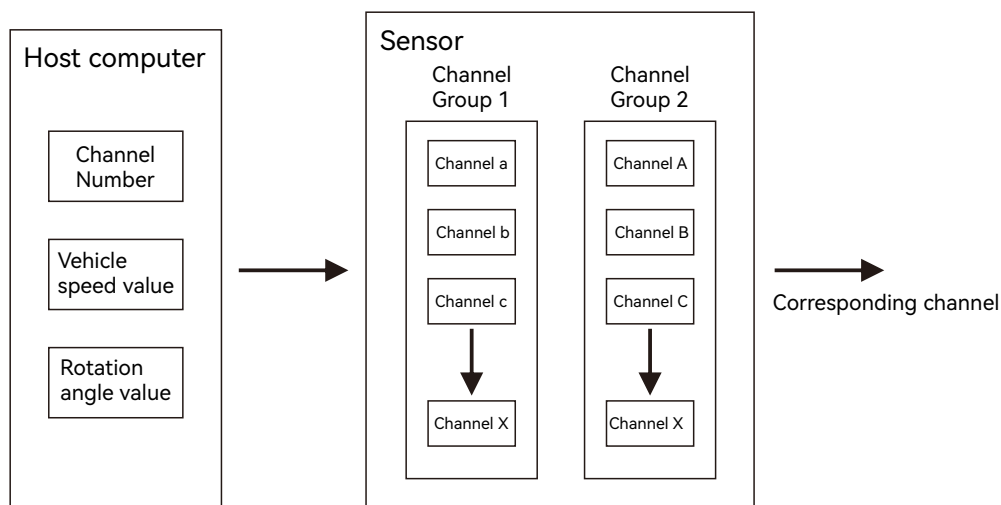

· Measured distance data output

Only supports RS232 and RS485 free protocols.

In the current state, the sensor returns real-time scanned measurement data, including the distance data measured at each point.

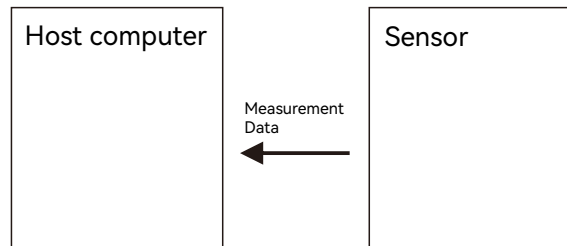

· Measurement intensity data output

Only supports RS232 and RS485 free protocols. In the current state, the sensor returns real-time scanned measurement data, including the reflection intensity data of each point. The intensity data provided by the sensor is relative data.

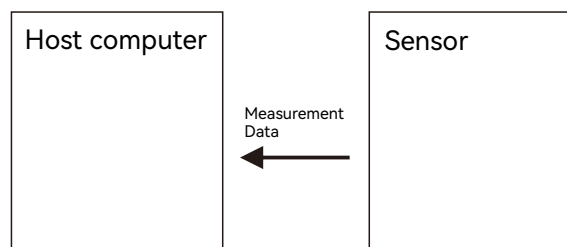

The following is a detailed description of the protocol for the host computer to obtain the three types of status data.

6.1 RS232/RS485 free protocol

For the following data to take effect, the sensor parameter named – sensor control mode must be set to RS232 free protocol or RS485 free protocol.

6.1.1 Communication mode

The communication mode adopts single master station and single slave station mode;

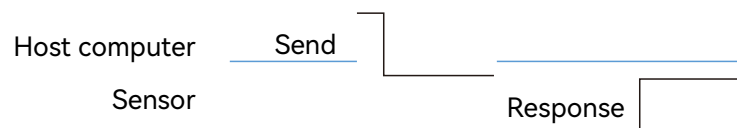

6.1.2 Communication Timing

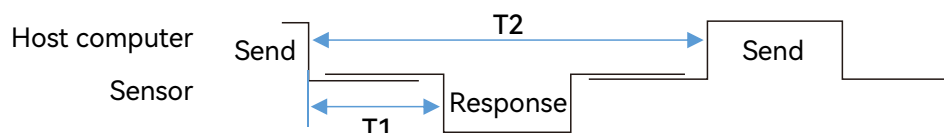

T1	Less than 2ms
T2	Channel control, recommended time is 50ms - 100ms Measurement data acquisition, recommended time is 200ms -500ms

6.1.3 Communication data

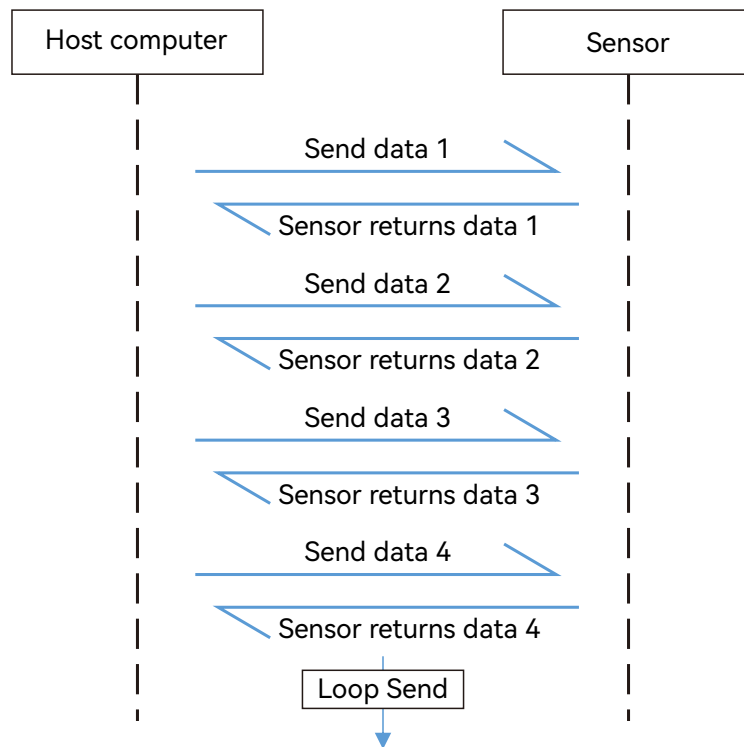

· Channel designation

Send data 1:

Control sensor in channel designation, in current mode the channel is controlled by the host computer

Sensor response data 1:

Response to the current status of the sensor and the status of the monitoring area

· Channel intelligent selection

Send data 2:

Control the sensor in intelligent channel selection, the sensor automatically selects the channel in the current mode

Sensor response data 2:

Response to the current status of the sensor and the status of the monitoring area

· Measured distance data output

Send data 3:

Specify the sensor to feedback the current scanned measurement data

Sensor response data 3:

Response to the current scanned measurement data

· Measurement intensity data output

Send data 4:

Specify the sensor to feedback the reflection intensity data of the current scan

Sensor response data 4:

Response to the reflection intensity data of the current scan

The following communication contents are listed in hexadecimal format, and the data transmission process is that the first byte is sent first.

Command Send data 1

Byte 1	Data identifier	
Byte 2		
Byte 3		
Byte 4		
Byte 5		
Byte 6	Sensor channel value	
Byte 7	Check bit	Low bit
Byte 8		High bit

Data identifier (5byte)

The identifier is fixed data: 53 43 68 69 6F This data function;

. Sensor channel value (1byte)

Controls the current sensing channel of the sensor, data range 00-3F (00-63);

. Check bit (2byte)

Data check bit, using modbus low-order CRC16 check method. The check value is calculated by the check formula, and the specific calculation method is detailed in the appendix.

Command Response data 1

Byte 1	Data identifier	
Byte 2		
Byte 3		
Byte 4		
Byte 5		
Byte 6	Current channel value	
Byte 7	OUT2 output status	
Byte 8	OUT1 output status	
Byte 9	OUT3 output status	
Byte 10	Invalid	
Byte 11	Sensor status	
Byte 12	Check bit	Low bit
Byte 13		High bit

. Data identifier (5byte)

The identifier is fixed data: 53 43 68 69 6F is used to mark the function of this data;

. Current channel value (1byte)

Current channel value of the sensor;

. OUT2 output status (1byte)

Related to the parameter setting item sensor output logic:

Normally closed mode (default)

00: object detected;

01: no object detected

Normally open mode

01: object detected;

00: no object detected;

- OUT1 output status (1byte)

Related to the parameter setting item sensor output logic:

Normally closed mode (default)

00: object detected;

01: no object detected

Normally open mode

01: object detected;

00: no object detected;

- OUT3 output status (1byte)

Related to the parameter setting item sensor output logic:

Normally closed mode (default)

00: object detected;

01: no object detected

Normally open mode

01: object detected;

00: no object detected;

- Invalid (1byte)

Invalid value: 00;

- Sensor status (1byte)

Sensor status 00 is normal status, non-00 value is sensor error code.

- Check bit (2byte)

Data check bit, using modbus low-order CRC16 check method. The check value is calculated by the check formula. For details on the calculation method, see the appendix.

Command

Send data 2

Byte 1	Data identifier	
Byte 2		
Byte 3		
Byte 4		
Byte 5		
Byte 6	Angle value	H
Byte 7		L
Byte 8	Speed value	H
Byte 9		L
Byte 10	Invalid	
Byte 11	Channel group number	
Byte 12	Check bit	Low bit
Byte 13		High bit

- Data identifier (5byte)

The identifier is fixed data: 53 43 61 73 65, used to mark the function of this data;

- Angle value (2byte)

Angle value in channel group mode, data is signed data range 00- B4 (-180-180);

- Speed value (2byte)

Speed value in channel group mode, data is signed data range 00- B4 (-300-300);

- Invalid (1byte)

Invalid value: 00;

- Channel group number (1byte)

Control sensor current sensing channel group number, data range 00-04 (00-04);

- Check bit (2byte)

Data check bit, using modbus low bit first CRC16 check method. The check value is calculated by the check formula, and the specific calculation method is detailed in the appendix.

Command Response data 2

Byte 1	Data identifier	
Byte 2		
Byte 3		
Byte 4		
Byte 5		
Byte 6	Current channel value	
Byte 7	OUT2 output status	
Byte 8	OUT1 output status	
Byte 9	OUT3 output status	
Byte 10	Invalid	
Byte 11	Sensor status	
Byte 12	Check bit	Low bit
Byte 13		High bit

- Data identifier (5byte)
The identifier is fixed data: 53 43 61 73 65, used to mark the function of this data;
- Current channel value (1byte)
The current channel value of the sensor;
- OUT2 output status (1byte)
Related to the sensor output logic of the parameter setting item:
Normal closed mode (default)
00: Object detected;
01: No object detected
Normal open mode
01: Object detected;
00: No object detected;
- OUT1 output status (1byte)
Related to the sensor output logic of the parameter setting item:
Normal closed mode (default)
00: Object detected;
01: No object detected
Normal open mode
01: Object detected;
00: No object detected;
- OUT3 output status (1byte)
Related to the sensor output logic of the parameter setting item:
Normal closed mode (default)
00: Object detected;
01: No object detected
Normal open mode
01: Object detected;
00: No object detected;

- Invalid (1byte)
Invalid value: 00;
- Sensor status (1byte)
Sensor status 00 is normal status, non-00 value is sensor error code.
- Check bit (2byte)
Data check bit, using modbus low-order CRC16 check method. The check value is calculated by the check formula. For details on the calculation method, see the appendix.

Command

Send data 3

Byte 1	Data identifier	
Byte 2		
Byte 3		
Byte 4		
Byte 5		
Byte 6	Check bit	Low bit
Byte 7		High bit

- Data identifier (5byte)
The identifier is fixed data: 52 53 63 61 6e, used to mark this data as the function of reading sensor measurement data;
- Check bit (2byte)
Data check bit, using modbus low-order CRC16 check method. The check value is calculated by the check formula. The specific calculation method is detailed in the appendix.

Command Response data 3

Byte 1	Data identifier	
Byte 2		
Byte 3		
Byte 4		
Byte 5		
Byte 6	Distance value of point 540	High bit
Byte 7		Low bit
Byte 8 Byte 1083	Distance value of point 539 to point 2	
Byte 1084		High bit
Byte 1085	Distance value of point 1	Low bit

- Data identifier (5byte)
The identifier is fixed data: 52 53 63 61 6e, used to mark this data as the function of reading sensor measurement data;
- 540th point position distance value (2byte)
Starting point measurement distance, data value range 0-6000, corresponding distance value 0-6000mm;
- 539th point to the 1st point distance value (1083byte)
According to 0.5°, one measurement point occupies 2Byte length, each point measurement distance data value range 0-6000, corresponding distance value 0-6000mm;

The position point corresponds to the sensor scanning position;

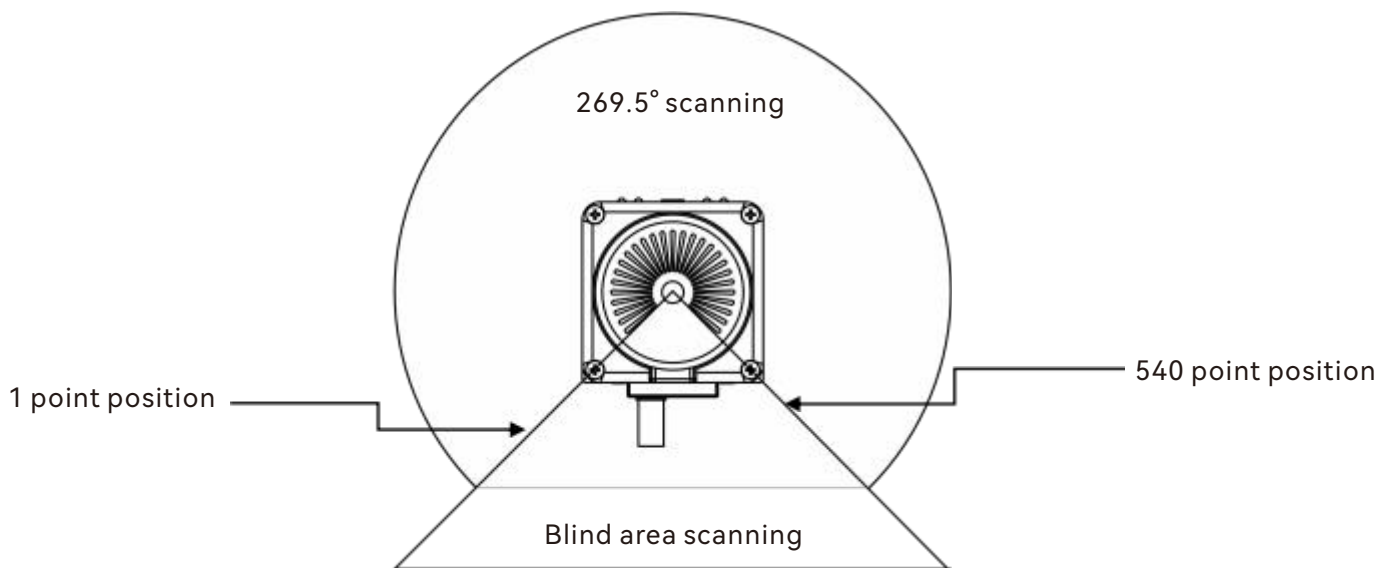

540th point position

Command Send data 4

Byte 1	Data identifier	
Byte 2		
Byte 3		
Byte 4		
Byte 5		
Byte 6	Check bit	Low bit
Byte 7		High bit

- Data identifier (5byte)
The identifier is fixed data: 52 53 74 72 65, used to mark this data as the function of reading sensor reflection intensity data;
- Check bit (2byte)
The data check bit adopts the modbus low-order CRC16 check method. The check value is calculated by the check formula. The specific calculation method is detailed in the appendix.

Command Response data 4

Byte 1	Data identifier	
Byte 2		
Byte 3		
Byte 4		
Byte 5		
Byte 6	Distance value of point 540	High bit
Byte 7		Low bit
Byte 8 Byte 1083	Distance value of point 539 to point 2	
Byte 1084	Distance value of point 1	High bit
Byte 1085		Low bit

- Data identifier (5byte)
The identifier is fixed data: 52 53 74 72 65, used to mark this data as the start code of the sensor reflection intensity data;
- Intensity value at the 540th point (2byte)
The starting point measurement distance, the data value range is 0-6000, and the corresponding distance value is 0-6000mm;
- Distance value from the 539th point to the 1st point (1083byte)
According to a measurement point of 0.5°, it occupies 2Byte length, and the measurement intensity data value range of each point is 00 00 – FF FF (0-10000);

The position point corresponds to the sensor scanning position;

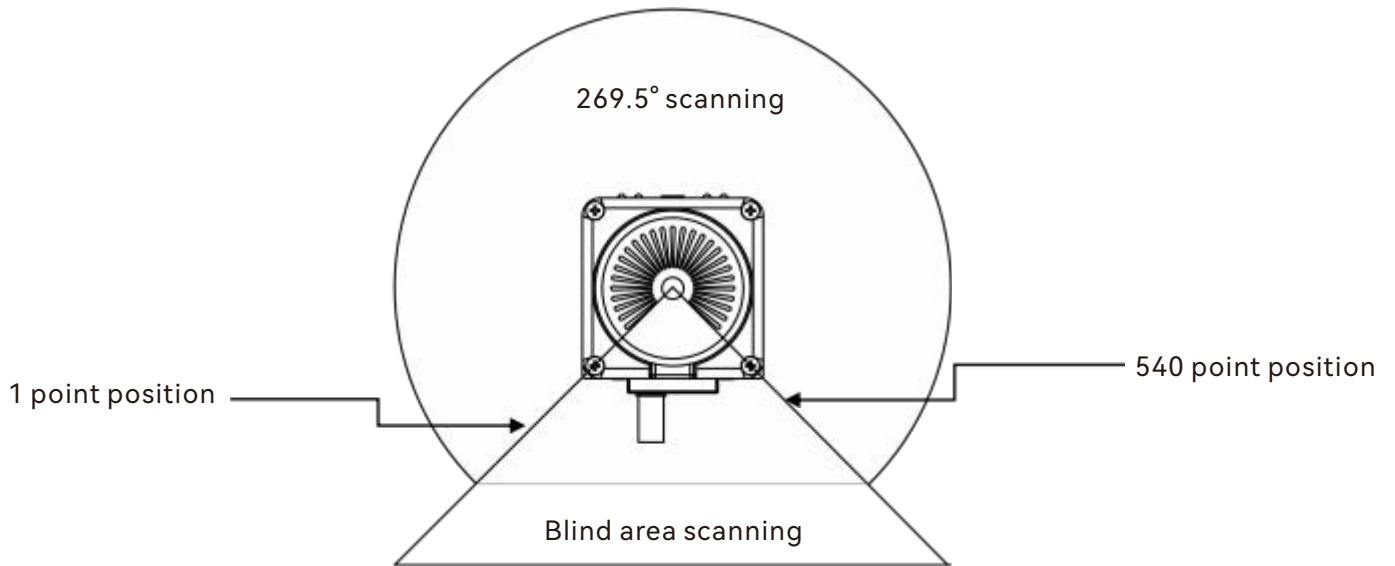

6.2 RS485-MODBUS protocol

Basic Information

The host computer needs to determine the parameters for setting MODBUS communication:

Slave address (slave): the communication address range of the sensor device is 1-127;

Read and write mode (mode): 04 (read status parameters) and 16 (write control parameters);

Start address (add): 1000 (read start register address) and 2000 (write start register address);

Number of reads (count): the number of registers read at a time;

MODBUS reads data and writes data separately, so they need to be processed separately when writing the host computer program.

6.2.1 Communication specifications

Before communication, you need to set the basic parameters of the serial port.

The following parameters are the basis for establishing communication.

	Parameters	Default settings
Communication mode	Single master/multiple slaves	
Working mode	MODBUS RTU mode	RTU mode
Receive/send mode	Half-duplex communication mode	
Communication ID	1-127 configurable	1/127
Communication rate	9600bps, 19200bps, 38400bps, 576000bps, 115200bps	115200bps
Data bit	8 bits	8 bits
Parity bit	No parity; odd parity; even parity	No parity
Stop bit	1 bit; 2 bits	1 bit

6.2.2 Master-slave communication sequence

The communication mode of MODBUS protocol is single master/multiple slaves mode, unicast mode

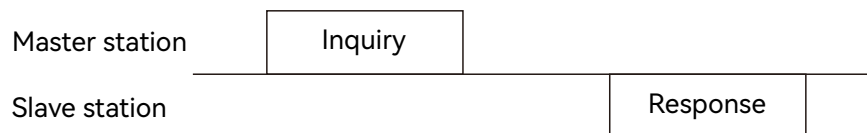

The master station sends a query to a slave station.

The slave station executes the processing and sends back a response.

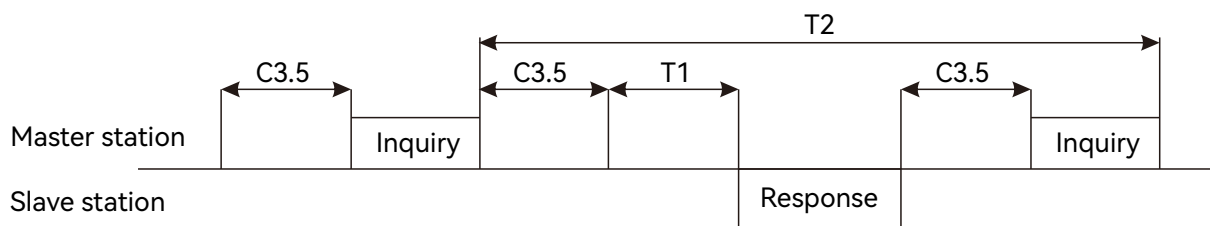

Serial number	Name	Content
C3.5	Quiet interval	As the sending waiting time, please make sure to leave an interval of more than 3.5 words. If the number of words is less than 3.5, the sensor will not respond. When the communication speed exceeds 19200 bps, please leave an interval of more than 1.75 ms.
T1	Send waiting time	After receiving the inquiry from the master station, the slave station switches the communication line to the sending state and starts to reply. The sending waiting time is 10 ms. The actual sending waiting time will become the static interval (C3.5) + command processing time + sending waiting time (T1)
T2	Communication timeout	Configurable from 0.05s – 1s

6.2.3 Data structure

Write holding register data format

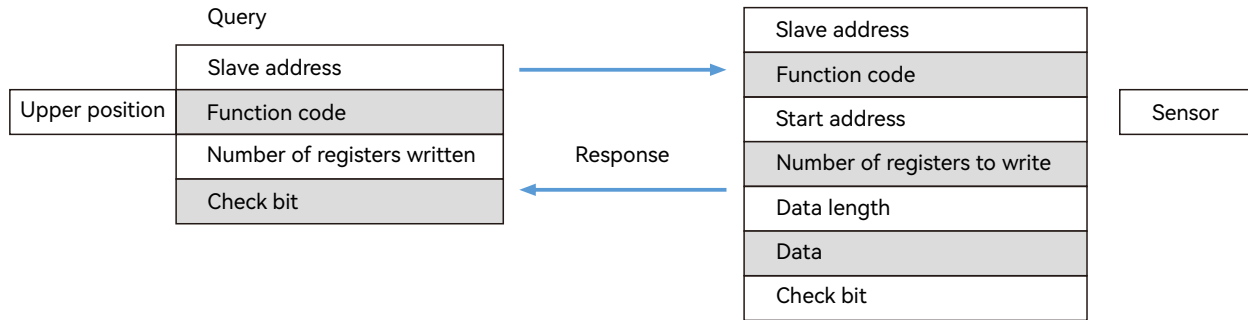

Command Query information structure

Slave address code	Function code	Start address	Number of registers to write	Data length	Data	Check bit
1Byte	1Byte	2Byte	2Byte	1Byte	(Number of registers written)*2Byte	2Byte

- Slave address
The specified slave address is the slave sensor address set by the configuration software;
- Function code
The write function code information supported by the sensor is as follows:

Function code	Function
16	Write data to the holding register

- Starting address
The starting address of the holding register written from the sensor starts from 2000;
- Number of registers to be written
The number of registers to be written starting from the starting address;
- Data length
The length of data written to the register = number of registers to be written * 2;
- Data
The data to be written starting from the starting address, the amount of data = number of registers to be written * 2Byte;
- Parity bit
Communication parity bit.

Command Response message structure

After receiving the inquiry information, the slave station responds with the following response data:

Slave address code	Function code	Start address	Number of registers to write	Check bit
1 Byte	1 Byte	2 Byte	2Byte	2 Byte

- Slave address
The specified slave address is the slave sensor address set by the configuration software;
- Function code
The write function code information supported by the sensor is as follows:

Function code	Function
16	Write data to the holding register

- Starting address
The starting address of the register to be written from the sensor, starting from 2000;
- Number of registers to be written
The number of registers to which data is written starting from the starting address;
- Parity bit
Communication parity bit.

Read input register data format

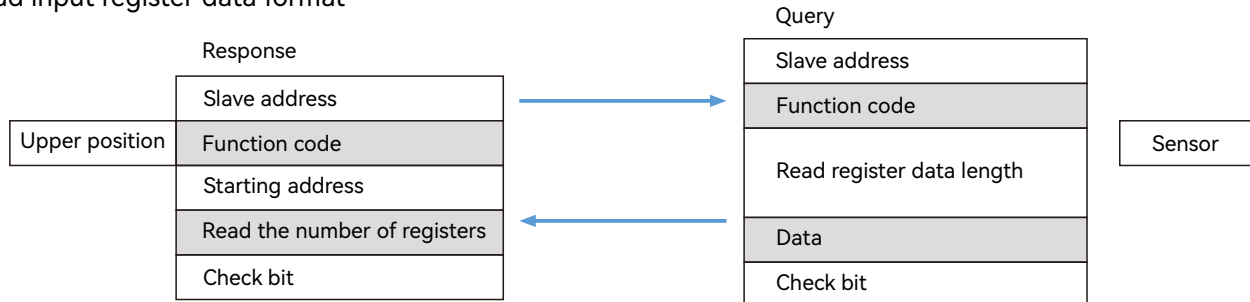

Command Query information structure

Slave address code	Function code	Start address	Read the number of registers	Check bit
1 Byte	1 Byte	2 Byte	1Byte	2 Byte

- Slave address
The specified slave address is the slave sensor address set by configuring the software;
- Function code
The read function code information supported by the sensor is as follows:

Function code	Function
04	Read data from input register

- Starting address
The starting address of the register read from the sensor, starting from 1000;
- Number of registers read
The number of registers read starting from the starting address;
- Check bit
Communication check bit.

Command Response message structure

After receiving the inquiry information, the slave station responds with the following response data:

Slave address code	Function code	Read register data length	Data	Check bit
1 Byte	1 Byte	1 Byte	(Number of registers to read) *2 Byte	2 Byte

- Slave address

The specified slave address is the slave sensor address set by the configuration software;

- Function code

The read function code information supported by the sensor is as follows:

Function code	Function
04H	Read data from input register

- Read register data length

The register data length that the host computer needs to read;

- Data

The register data that the host computer needs to read. Since one register is 2Byte, the length of this data segment is the number of registers to read*2Byte;

- Check bit

Communication check bit.

6.2.4 Register Definition

Write holding register function (function code 16)

Register address	Write value	Content
2000	00 - 01	Sensor working mode 00: Channel specified mode 01: Intelligent channel selection mode
2001	00 - 63	Control sensor channel value in channel specified mode 1-63
2002	-180-180	Switching angle value in intelligent channel selection mode
2003	-300-300	Switching speed value in intelligent channel selection mode
2004	00 - 04	Channel group number in intelligent channel selection mode 0-4

Read input register function (function code 04)

Register address	Read value	Content
1000	00 – 63	Current channel value of the sensor
1001	00 – 01	<p>Sensor Out2 output status Related to the parameter setting item sensor output logic: Normally closed mode (default) 00: object detected; 01: no object detected Normally open mode 01: object detected; 00: no object detected;</p>
1002	00 – 01	<p>Sensor Out1 output status Related to the parameter setting item sensor output logic: Normally closed mode (default) 00: Object detected; 01: No object detected Normally open mode 01: Object detected; 00: No object detected;</p>
1003	00 – 01	<p>Sensor Out3 output status Related to the parameter setting item sensor output logic: Normally closed mode (default) 00: Object detected; 01: No object detected Normally open mode 01: Object detected; 00: No object detected;</p>
1004	0–7	<p>Displays the current status of the sensor, with a value range of 00–07; 00: sensor normal status; 01–07: sensor fault status;</p>

6.3 CAN BUS Free Protocol

For the following data to take effect, the sensor parameter named - sensor control mode must be set to CAN BUS-HS protocol mode.

6.3.1 Communication

CAN BUS communication mode adopts bus communication mode;

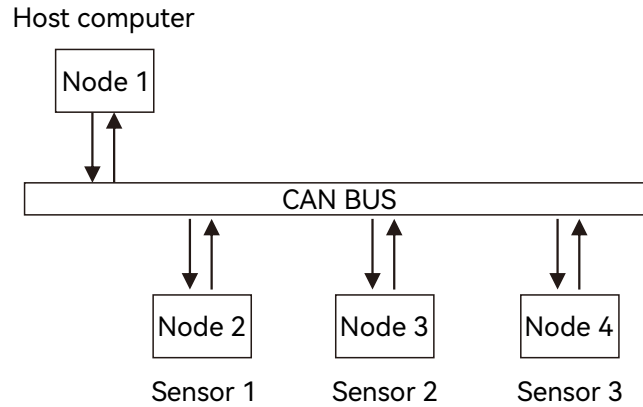

6.3.2 Communication specifications

Communication mode	Bus mode
Communication rate	1000k (default), 500k, 250k, 125k
Data frame	Standard frame
Communication standard	CAN BUS 2.0 B
Broadcast time	0 (no broadcast) -500ms
Supported protocol	CAN-HS protocol CAN OPEN protocol

6.3.3 Communication Timing

In non-broadcast mode

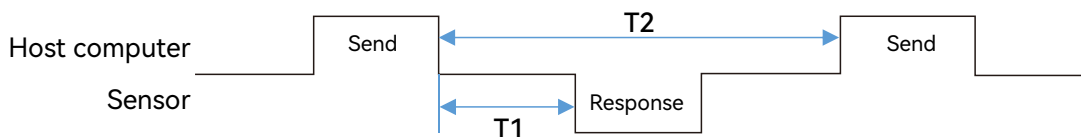

T1	Less than 1ms
T2	The recommended time is 50ms-100ms.

6.3.4 Communication data

The sensor has two working modes, which are as follows;

Channel assignment: completely controlled by the host computer.

Intelligent channel selection: automatically switch channels according to the input speed value and angle value in the corresponding channel group.

Channel assignment

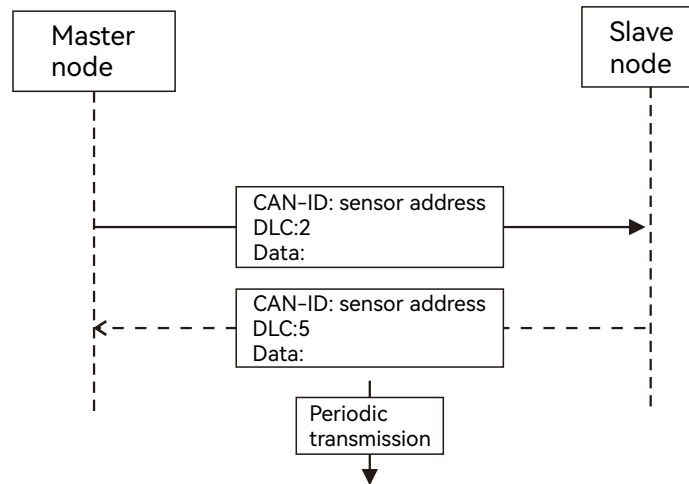

Send data

CAN ID	DLC	Data	
CAN Bus communication address	2	0 byte	1 byte
		0x 00	Channel number

- CAN ID
Command The CAN bus communication address set by the sensor

For example

Sensor parameter setting, CAN bus communication address is 0x05;
(For specific settings, please refer to the configuration software manual)

- 1 Byte
Invalid data, 00;
- 2, 3Byte driving angle value
The data range is - 180- 180;
- 4 and 5 Byte vehicle speed value
The data range is -300-300
- 6 Byte
Invalid data, 00;
- 7 Byte-Channel group number
Control the current channel group number of the sensor, the data range is 0-4;

Response data

CAN ID	DLC	Data				
CAN		0 byte	1 byte	2 byte	3 byte	4 byte
Bus communication address	5	Current channel code	Out1 output status	Out2 output status	Out3 output status	Fault status

- CAN ID
CAN bus communication address set by the sensor

For example

Sensor parameter setting, CAN bus communication address is 0x05;
(For specific settings, please refer to the configuration software manual)

- 0 Byte—Current channel group number
When the channel number used by the sensor, the data range is 0-4;
- 1 Byte --OUT1 output status
Related to the parameter setting item sensor output logic:
Normally closed mode (default)
00: object detected;
01: no object detected
Normally open mode
01: object detected;
00: no object detected;
- 2 Byte ---OUT2 output status
Related to the parameter setting item sensor output logic:
Normally closed mode (default)
00: Object detected;
01: Object not detected
Normally open mode
01: Object detected;
00: Object not detected;
- 3 Byte ---OUT3 output status
Related to the parameter setting item sensor output logic:
Normally closed mode (default)
00: Object detected;
01: Object not detected
Normally open mode
01: Object detected;
00: Object not detected;
- 4 Byte – Fault Status
Shows the current status of the sensor, the value range is 00-07;
00: sensor normal status;
01-07: sensor fault status;

7 Troubleshooting

7.1 Fault Status

The sensor indicates a fault through the green LED light of the sensor power status. When the green LED flashes, the sensor will stop outputting signals.

LED flashes	Sensor failure
LED is always ON	Normal state

7.2 Troubleshooting

When a sensor fails to work properly or the sensor status cannot be determined, follow the process below to troubleshoot and confirm the problem.

Fault	Solve
Unable to detect objects	Use the configuration software to view and monitor the current channel status and drawn detection areas.
Channel cannot be switched	Check whether the IN1-IN6 signal input is correct;
Output signal flashes	1) When the sensing range is at a critical point, the output port may become unstable. If necessary, you should consider expanding the protection area. 2) There is dust on the sensor window;

8 After-sales information

8.1 Warranty Period

DK-LD-10HN provides a limited warranty. During the warranty period, if the product cannot be used normally due to quality problems, design defects, etc., we will provide free after-sales maintenance.

- Warranty period: 2 years from the date of sale.

8.2 Scope of Warranty

If the product is within the warranty period and falls within the warranty conditions, we will repair or replace it free of charge

- The warranty and after-sales service of this product are limited to mainland China;
- The product cannot be used normally due to unpacking during transportation;
- The product cannot work normally due to damage to the components of the product itself;
- The product cannot be used normally due to design defects;

8.3 Scope of Disclaimer

Please pay attention to the following conditions during the use of the product. We will not provide free after-sales and warranty.

- Failure to install the product correctly according to the instructions, resulting in product damage;
- Use the product in an unsuitable environment and conditions, resulting in product damage;
- Product damage caused by failure to operate in accordance with the product manual;
- Unauthorized disassembly or repair of the product without the company's permission;
- Product damage caused by irresistible external forces such as natural disasters and fires.

8.4 Technical Support

DADISICK TECHNOLOGY LIMITED
<https://www.dadisick.com>