

TWO-DIMENSIONAL TOF OBSTACLE AVOIDANCE LASER RADAR

DK-LD-05D



Product parameters

Basic Information		
product name	two-dimensional tof obstacle avoidance laser radar	
Product number	DK-LD-05DN	DK-LD-05DP
	NPN	PNP
Features		
Laser source	905 nm(class I)	
Scan angle range	270°	
scanning frequency	15Hz	
Angle resolution	0.1°	
Work area	0.05m~5m	
Self-learning function	Automatic environment scanning, generating area	
Mechanical/electronic parameters		
Electrical connections	DB15 MALE/SCATTER	
Supply voltage	DC 9 V ~ 2 8 V	
Power consumption	2W	
Switch drive	DC 30 V 50 mA MAX	
Shell color	Yellow	
Protection level	IP65	
weight	150g, no cable	
Size (length × width × height)	50mm×50mm×76mm	
Performance		
Recognizable object shape	Almost any shape	
Measurement error	±3mm	
Number of regional groups	16 regional groups, each containing 3 regions	
interface		
USB	Micro - USB	
Input	GND / NCX 4	
Switch output	NPNx3, device working status indication X1	
Signal output hold time	100ms~10,000ms (adjustable) typical value 330ms	
Response time	Status Indicators	
Status Indicator	Status indication 1, area group indication 2	
Environmental parameters		
Vibration resistant	10-55Hz, amplitude 0.75mm, XYZ three-axis, 2 hours per axis; 50-200hz, 196m/s ² (20G), scanning speed 2min/cycle, XYZ three-axis, 2 hours per axis	
Working temperature	-10°C~+55°C	
Storage temperature range	-30°C~+75°C	
Resistance to ambient light	>15,000ux	

Dimension

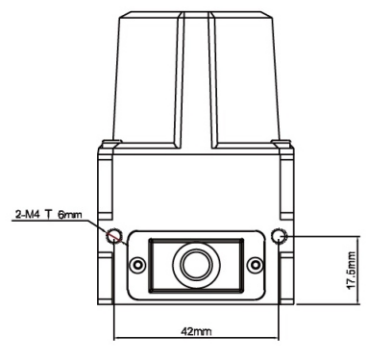
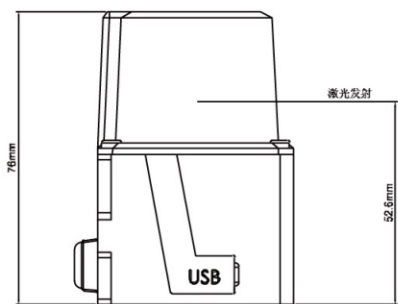
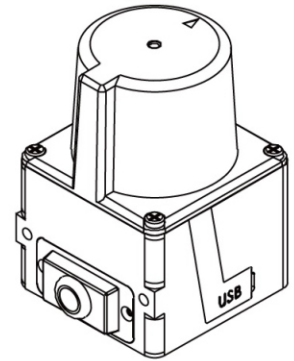
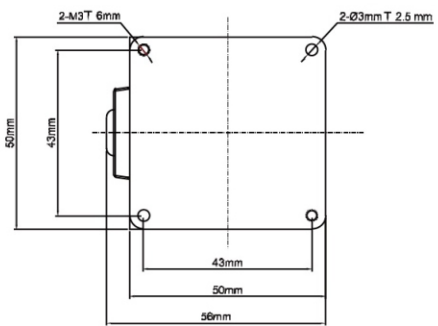



Features

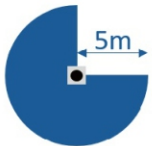

5m distance
270°angle



Multi-zone monitoring
Monitoring area independent setting



External device driver
The switch provides
DC 30V 50mA driving force



16 regional group settings
Quick configuration fast loading

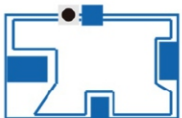

Automatic learning
Learning based on field scenarios
Monitoring profile



**Suspend function,
take into account production**
Built-in shutdown and restart function
Cooperate with production line to
move countermeasures



IP65
Dustproof and waterproof
Applicable in harsh industrial environments

Point Cloud

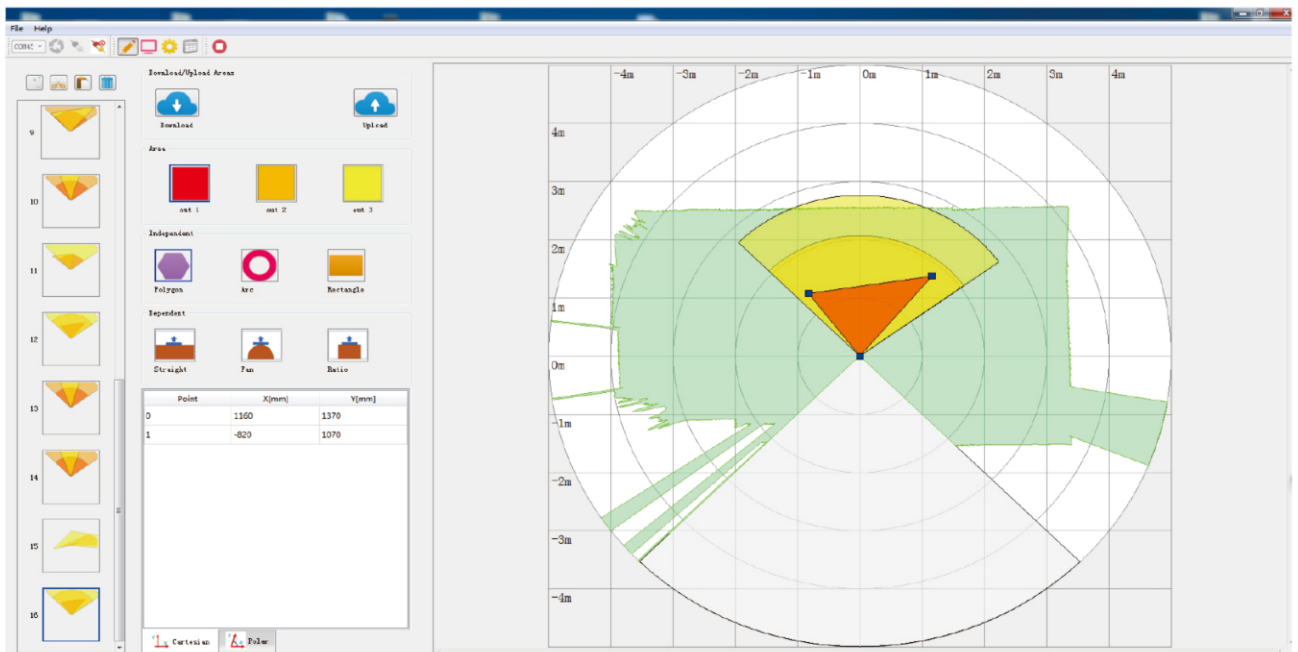

Application



AGV obstacle avoidance



Factory area operation safety protection



Service robot autonomous obstacle avoidance



Unmanned near field obstacle avoidance



WhatsApp/WeChat/Tel: **+86 13713346108**

Email: **sale@dadisick.com**

Website: **www.dadisick.com**



DADISICK TECHNOLOGY LIMITED

No.33 Sanjiang Industrial Area, Hengli Town,
Dongguan City, Guangdong Province P.R.China.

