



Obstacle avoidance single line radar a as ries

DADISICK TECHNOLOGY LIMITED

(all rights reserved)

1. Safety instructions	4
2. Equipment appearance	6
3. Working principle	8
3.1 ranging principle	8
3.2 working mode	9
3.3 area definition	10
3.3.1 working mode	10
3.3.2 area definition	12
3.4 Region selection	13
3.5 Intrusion alarm	14
4. Working parameters	16
4.1 Variable parameters	16
4.1.1 Shielding size	16
4.1.2 response time	16
4.1.3 Hold time	16
4.2 Equipment parameters	16
4.2.1 Angular resolution	16
4.2.2 Scanning angle range	16
4.2.3 Communication rate	17
4.2.4 Power on times	17
4.2.5 Working time	17
4.2.6 Total working hours	17
5. equipment installation	18
5.1 Mechanical Dimensions	18
5.2 Mechanical installation	18
5.3 Optical interference	19
5.4 Mutual interference	19
5.5 Electrical connection	20
5.5.1 Connects Cables	20
5.5.2 Input circuit	22
5.5.3 output circuit	22
5.6 Indicator Status	23
6. classic case	24
6.1 access control	24
6.2 Protrusion detection	25
6.3 Regional protection	25
7. Equipment inspection and maintenance	27
7.1 View before use	27
7.2 Daily inspection!	27
7.3 rregular inspection	28
8. Product performance parameters	29

Revision history

content	edition
First release	1.0.0
1. Increase support for adjustable motor speed 2. Increase support for shielding size	1.0.1
Update response time parameters	1.0.3
1. In the process of self-learning, the problem of point cloud flickering 2. Support self-learning by software 3. After the radar is powered on and before starting, the area gives an alarm signal, that is, the radar is not normalBefore operation, output is in alarm state 4. Alarm output signal level can be configured	1.0.4
1. Add log function 2. Add write flash protection 3. Solve the problem of program hang up in the process of serial port device identification 4. Solve the abnormal program crash caused by power failure when the program is running	1.0.5

1 Safety instructions

General safety summary

Please read the following safety precautions carefully to avoid damaging this product or other products connected with this product.

Use the specified power cord:

Only the power cord approved by the host country is allowed to be used;

To view product ratings:

To avoid the impact of excessive current, please check the rating and marking instructions marked on the product, and consult the product manual for details of rating before connecting the product;

Always use suitable over-voltage protection:

Make sure that no high voltage is connected to the product.

Ground the product:

Ground the power cable of this product. To avoid electric shock, before connecting any input or output terminal of the product, please ensure that the grounding terminal of the power cable of the product is reliably connected with the protective grounding terminal;

It is forbidden to disassemble the instrument and open the cover without permission:

Without the permission of siminics, the user can not disassemble the device without permission, and it is strictly prohibited to open the product when the device is running;

Do not use hard objects to scratch the optical cover:

Scratches of foreign objects may cause scratches on the optical cover, surface scratches may affect the measurement distance, or increase the noise data;

Anti static protection:

Static electricity may cause damage to the instrument, so it should be tested in the anti-static area or under the premise of good grounding.

In case of suspected product failure, it is forbidden to operate:

If you suspect that this product is faulty, please contact siminics for testing. Any maintenance, adjustment or part replacement must be performed by siminics;

Do not use in corrosive environment:

In order to prevent the equipment from being damaged by corrosion, it is strictly prohibited to use or place the equipment in a corrosive environment;

Do not operate in flammable and explosive environment:

In order to avoid equipment damage and personal safety, it is strictly prohibited to operate or place the instrument in inflammable and explosive environment;

Keep the optical surface of the product clean:

In order to avoid dust affecting the ranging performance, please keep the optical surface of the product clean;

Keep good heat dissipation:

Please install the equipment on the surface of metal heat sink to keep good heat dissipation.

Do not look straight for a long time

The equipment has continuous infrared laser emission during operation, which meets the class I laser safety standard. To ensure safety, do not look directly at the light-emitting surface for a long time.

2 Appearance of equipment

The appearance of radar is shown as follows:

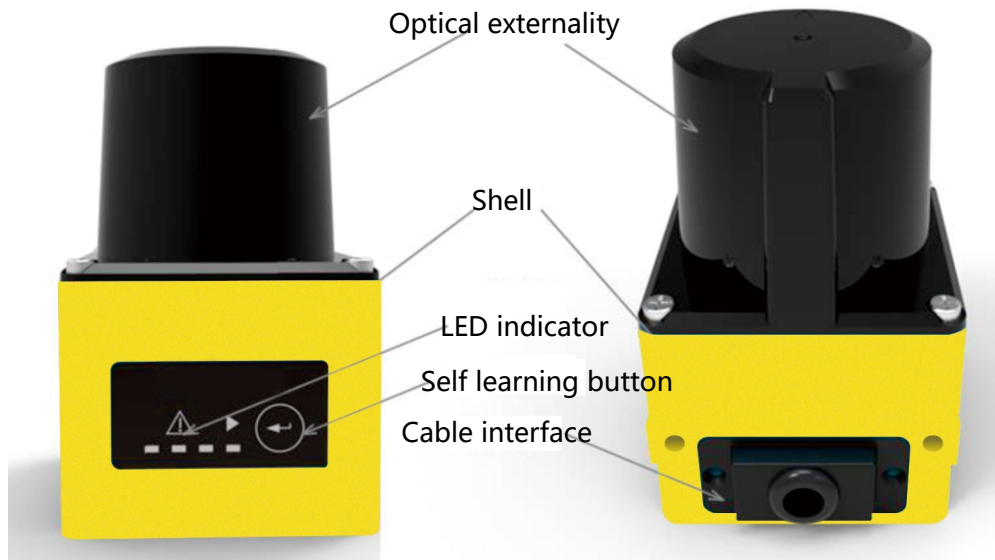

Figure 2-1 radar appearance 1

Note:

1. Optical cover: the optical cover is made of plastic. Please be careful that the cover is scratched by sharp tools, which will affect the optical performance.
2. LED indicator: the indicator has two functions a) When radar is working, if there is an object invading the working area, it will give an alarm through the LED indicator light. b) Indicates whether radar is working properly.
3. Self learning button: radar has self-learning function. It can scan the surrounding environment to build the region and region group.



Figure 2-2 radar appearance 2

Note:

USB interface: radar is connected to the upper computer through micro USB.

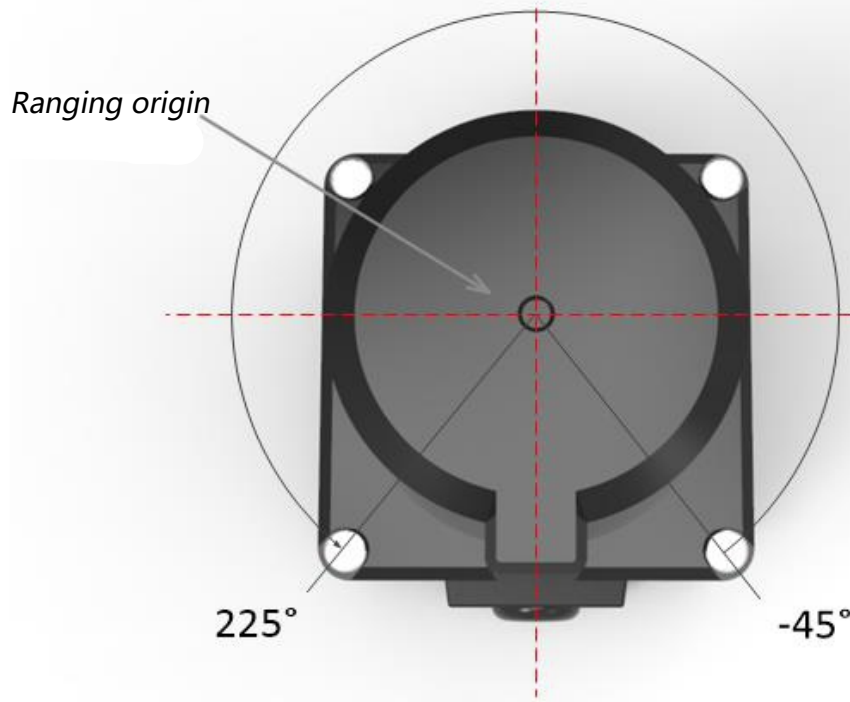

Figure 2-3 scanning angle

Note:

The angle scanning range of air is 270 ° from - 45 ° to 225 °.

In the actual display, due to the limit of angular resolution, the actual value of the angle range is different under different motor speeds:

Motor speed 15Hz (angle resolution 0.1 °): actual value of angle range, min. - 45 °, max. 224.9 °.

Motor speed 30Hz (angle resolution 0.3 °): actual value of angle range, min. - 45 °, max. 224.7 °.

3 Working principle

3.1 Ranging principle

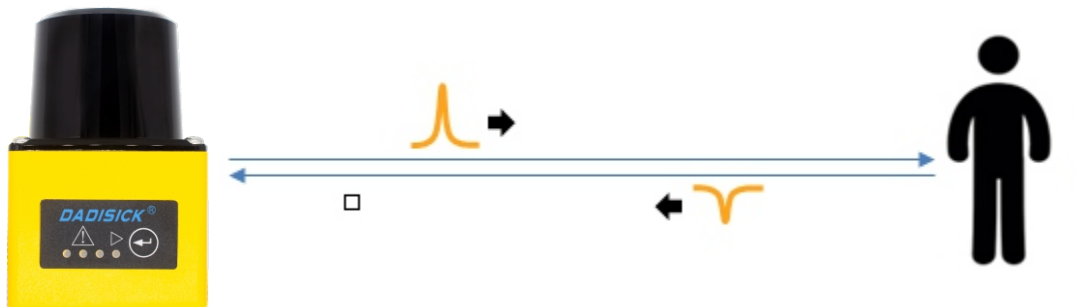

Figure 3-1 schematic diagram of lidar ranging principle

The calculation of object size is shown in the figure below:

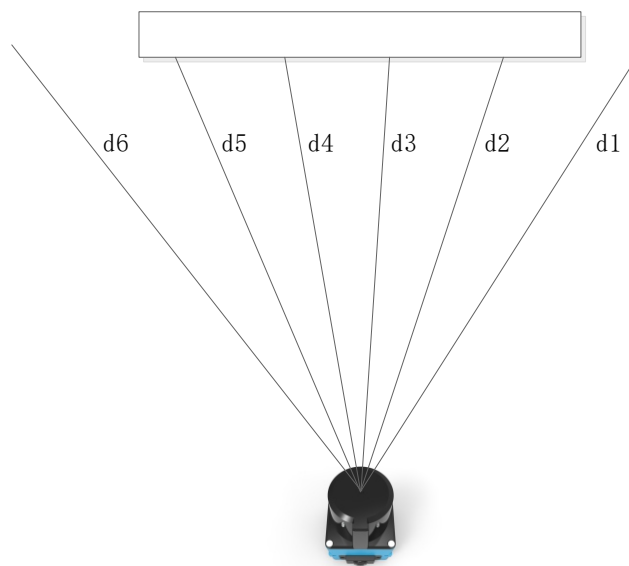

Figure 3-2 calculation method of object size

d1, d2 ... D6: it indicates the distance between the object and lidar, and the angle difference between them is the angle resolution of radar.

The calculation formula of the object size is:

$$W = (d2 + d3 + d4 + d5) \cdot \theta$$

among, $\theta = 2\pi/3600$

Because of the parameter "shielding size", when w is larger than the shielding size, the obstacle avoidance radar will alarm.

3.2 working mode

radar has four modes of operation:

1. Monitoring mode

This mode is radar normal operation mode. When an object intrudes, the radar will alarm through LED light and corresponding output signal.

When radar is powered on, it will enter monitoring mode automatically.

2. Edit mode

This mode is the working mode when the user edits the radar workspace group.

The user uses radar designer software to edit the area and area group, so that the radar enters editing mode.

3. Self learning mode

Users scan the surrounding environment through radar to generate the mode of working area group. Long press the "self-learning button" on the radar shell to make radar enter the self-learning mode, as shown in the figure:



Figure 3-3 self learning button

4. Standby mode

radar is in standby mode and stops working. The main features are:

- (1) The motor stops turning.
- (2) Click cloud to stop uploading.
- (3) The regional group is uploaded and downloaded normally.

The user enters the radar into standby mode by inputting signals.

3.3 Area definition

radar monitors the range specified by the user. When an object enters the range, the radar will alarm the main control equipment, and the defined range is "area".

3.3.1 Area type

According to the geometry of the region and its relationship with other regions, the regions are divided into the following types:

1. Polygon area

The points defined by the user and the origin are connected to form a polygon area.

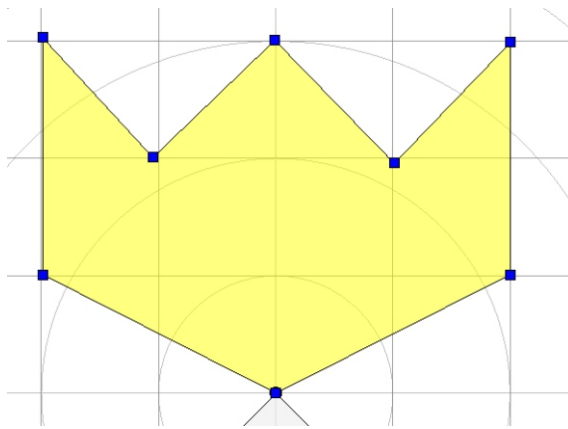

Figure 3-4 polygon area

2. Rectangular area

It is connected by two user-defined points (top left and bottom right) and the origin to form a rectangular area.

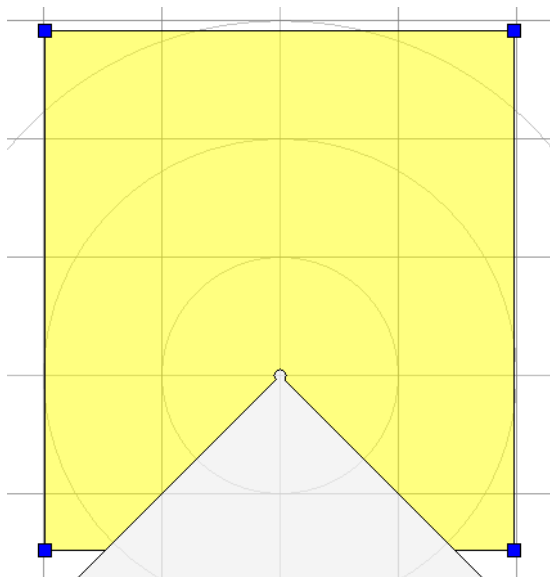

Figure 3-5 rectangular area

3. Arc area

It is connected by two points and the origin to form an arc area.

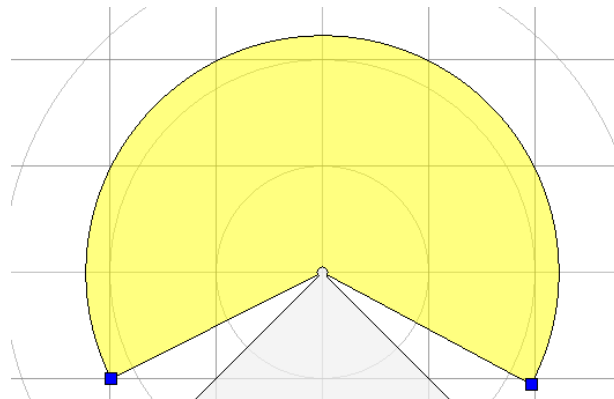

Figure 3-6 arc area

4. Linear scale area

The outer region serves as the reference region, the region where the line intersects the outer region.

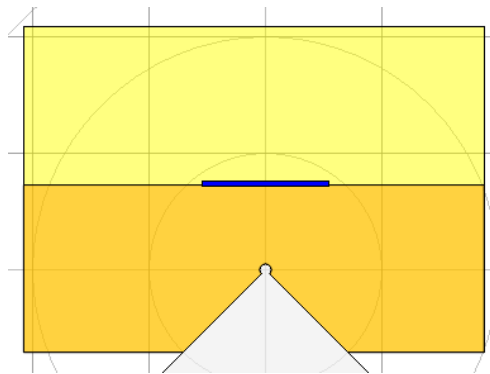

Figure 3-7 linear scale area

5. Sector scale area

The outer region serves as the reference region, which is formed by the intersection of the arc and the outer region.

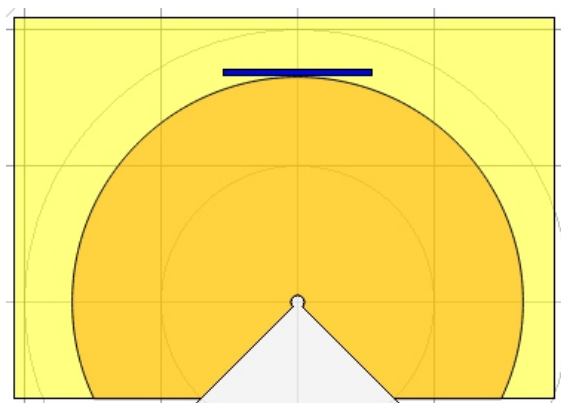

Figure 3-8 sector scale area

6. Full scale area

The outer region serves as the reference region, and the arc is generated in proportion to the inner region.

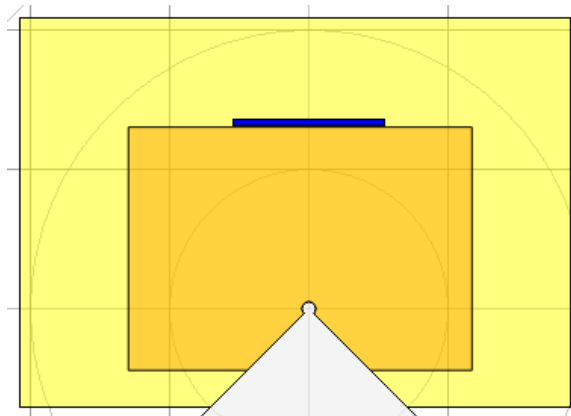

Figure 3-9 full scale area

When defining an area, pay attention to the following:

- The points defining polygon, rectangle and arc must be within - 5 ~ 5m (radar range).
- All regions are undefined between - 90 ° and - 45 °.
- The scale area is within the upper level area.

3.3.2 regional groups

A region group consists of three regions: region 1 (red), region 2 (Orange), and region 3 (yellow). The areas within the group can be independent or related to each other, and users can set them according to their needs. As shown in the figure:

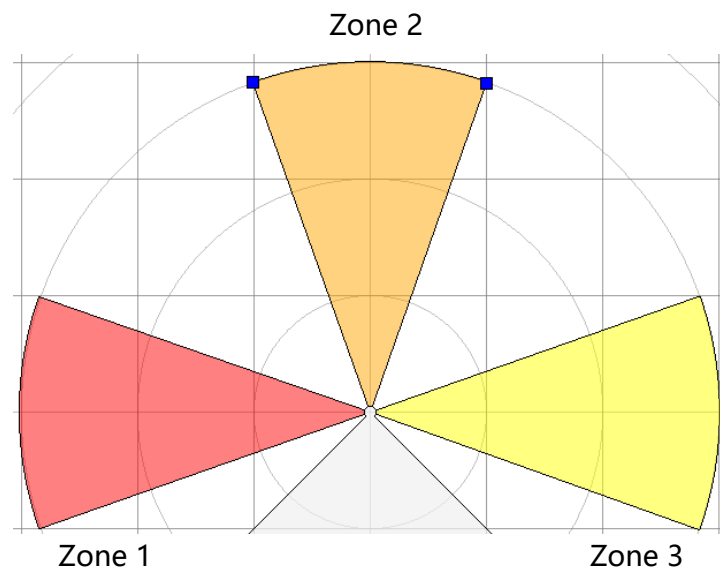

Figure 3-10 area groups - separate areas

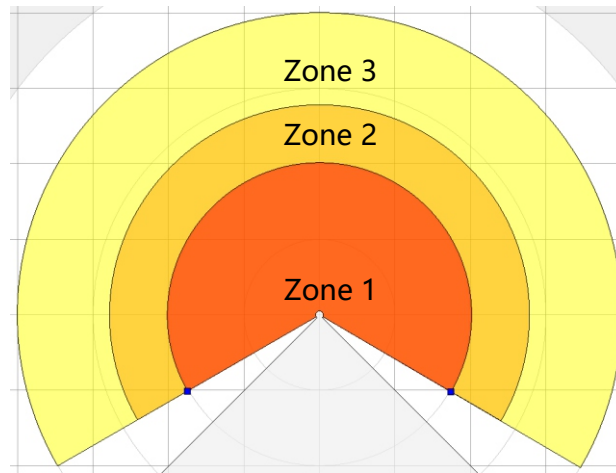

Figure 3-11 area groups - associated areas

When an object intrudes into an area, its corresponding LED light will be lit, and its corresponding output signal will also become high level.

3.4 Area selection

radar supports 16 area groups. The user selects the current working area group through the combination of input signals to switch the area group.

The relationship between area group and input signal is shown in the following table:

Regional group number	Input4	Input3	Input2	Input1
Regional Group 1	0	0	0	0
Regional Group 2	0	0	0	1
Regional Group 3	0	0	1	0
Regional Group 4	0	0	1	1
Regional Group 5	0	1	0	0
Regional Group 6	0	1	0	1
Regional Group 7	0	1	1	0
Regional Group 8	0	1	1	1
Regional Group 9	1	0	0	0
Regional Group 10	1	0	0	1
Regional Group 11	1	0	1	0
Regional Group 12	1	0	1	1
Regional Group 13	1	1	0	0
Regional Group 14	1	1	0	1
Regional Group 15	1	1	1	0
Regional Group 16	1	1	1	1

Note:

1. The input signal is floating enabled, and the value is "1".
2. Input grounding is not enabled, the value is "0".

3.5 Intrusion alarm

When radar detects that an object has invaded the work area, it will alarm through the output signal and LED [1-3] light. The relationship is shown in the table:

Intrusion detection			Signal output			Indicator light		
Zone 1	Zone 2	Zone 3	Output1	Output2	Output3	Led1	Led2	Led3
0	0	0	0	0	0	OFF	OFF	OFF
1	0	0	1	0	0	ON	OFF	OFF
0	1	0	0	1	0	OFF	ON	OFF
1	1	0	1	1	0	ON	ON	OFF
0	0	1	0	0	1	OFF	OFF	ON
1	0	1	1	0	1	ON	OFF	ON
0	1	1	0	1	1	OFF	ON	ON
1	1	1	1	1	1	ON	ON	ON

Note:

1. The area is "1", indicating that there is an object intrusion in this area; "0", indicating that there is no intrusion.
2. Output is "1", indicating that the output signal indicates that there is an object intrusion; "0", indicating that there is no intrusion.
3. "ON" indicates that the LED is on, and "OFF" indicates that the LED is off.

3.6 Self-learning

The user can set the work area through the radar Designer software. However, for some actual work scenarios, the user needs to measure accurately to draw the area.

radar provides self-learning function. When the user presses the "self-learning" button for 3 seconds, radar enters self-learning mode. It will automatically scan the surrounding environment, and the outline of the scanned environment is the boundary of the area.

4. Working parameters

4.1 Variable parameters

4.1.1 Motor speed

There are two values to control the motor speed of the laser transmitter: 15Hz and 30Hz. When the speed changes, the angular resolution of the machine also changes.

The specific values are:

15Hz: angular resolution 0.1 °

30Hz: angular resolution 0.3 °

4.1.2 Shield size

If the intruding object is smaller than this size, radar will not alarm.

Value range: 10mm ~ 1,000mm, default value: 10mm.

4.1.3 Response time

When the radar detects an intrusive object, how long after it alarms. According to different angular resolutions (ie different speeds), the response time ranges are different.

At 15Hz: Value range: 67ms ~ 29,949ms (\approx 30s), the default value is 134ms (the motor rotates twice)

At 30Hz: Value range: 33ms ~ 29,997ms (\approx 30s), the default value is 66ms (the motor rotates twice).

4.1.4 Holding time

When the intruder leaves the protected area, the time that the output signal remains in the alarm state.

Value range: 10ms ~ 10,000ms (10s), the default value is 330ms.

4.2 Device parameters

Only the parameters related to the distance calculation are listed here. For other parameters, please refer to the appendix.

4.2.1 Angular resolution

The angle difference between two adjacent laser pulses, the angular resolution is 0.1 ° at a motor speed of 15 Hz, and the angular resolution is 0.3 ° at a motor speed of 30 Hz.

4.2.2 Scanning angle range

The minimum angle and maximum angle range of the laser pulse.

At 15Hz: The angle range is -45 ° to 224.9 °.

At 30Hz: The angle range is -45 ° to 224.7 °.

4.2.3 Communication rate

radar and the host computer use USB to serial communication, the baud rate is 2941176bps.

4.2.4 Number of power-on

radar The total number of power-on times.

4.2.5 The working time

How long has radar worked since this power-up.

4.2.6 Total working hours

radar has been working since the first power-on.

5. Equipment installation

5.1 Mechanical dimensions

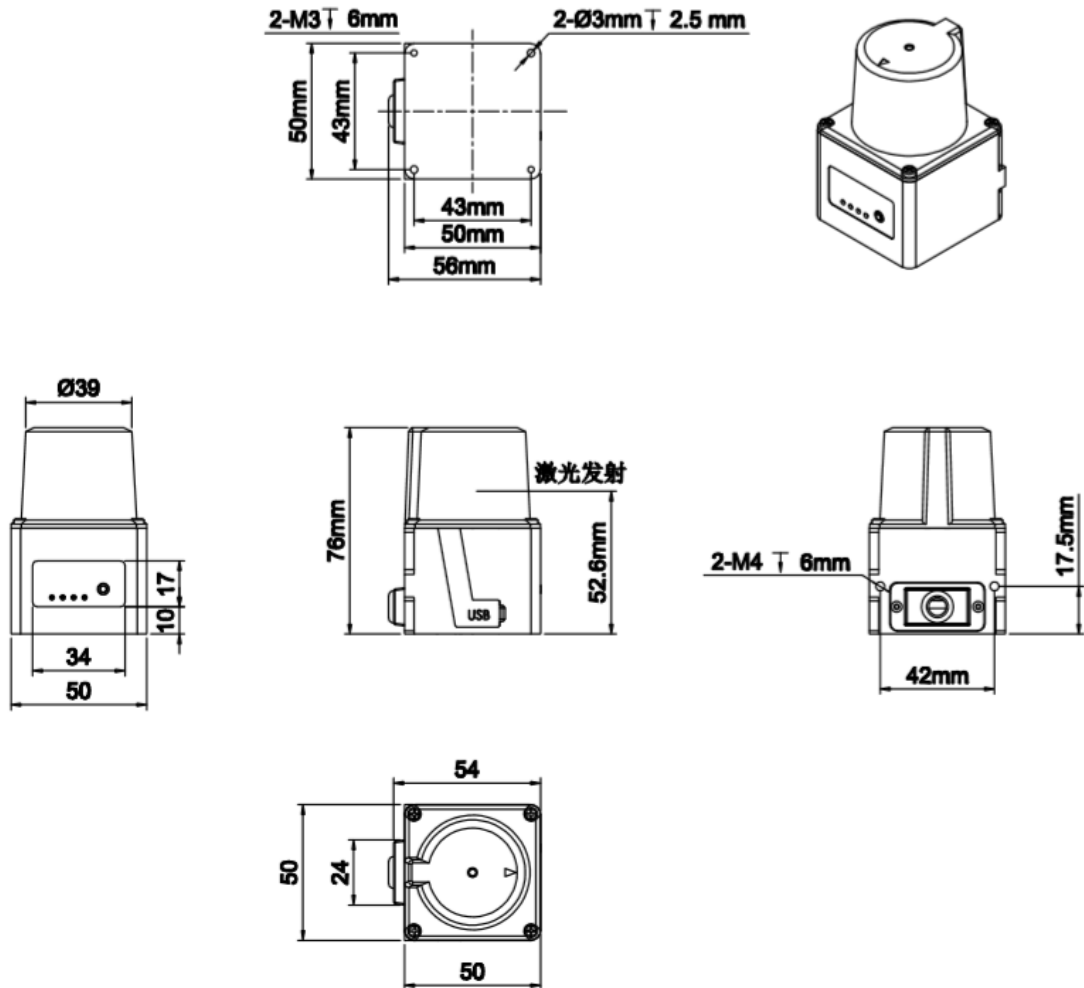

Figure 5-1 radar mechanical dimensions

5.2 Mechanical installation

There are mounting screw holes on the bottom and sides of radar, users can use standard screws to fix the radar. As shown:



Figure 5-2 radar basic installation

5.3 Optical interference

radar uses laser pulses to detect surrounding objects. If there is interference light source in the working range, its detection ability will be affected, and even lead to false alarm.

If the user cannot remove the disturbing light source in the working environment, please place the light source at least within $\pm 3^\circ$ of the radar.

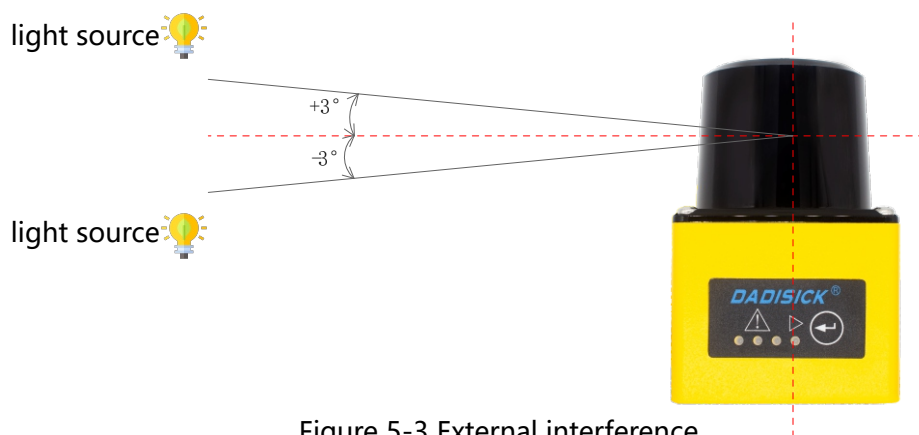

Figure 5-3 External interference

5.4 Mutual interference

If two or more radar lidars work together, they will cause interference with each other. The figure below provides installation methods to avoid such interference.

1. Vertical installation

By changing the installation height of the radar, the radar laser scanning planes are at different heights, so as to avoid mutual interference.

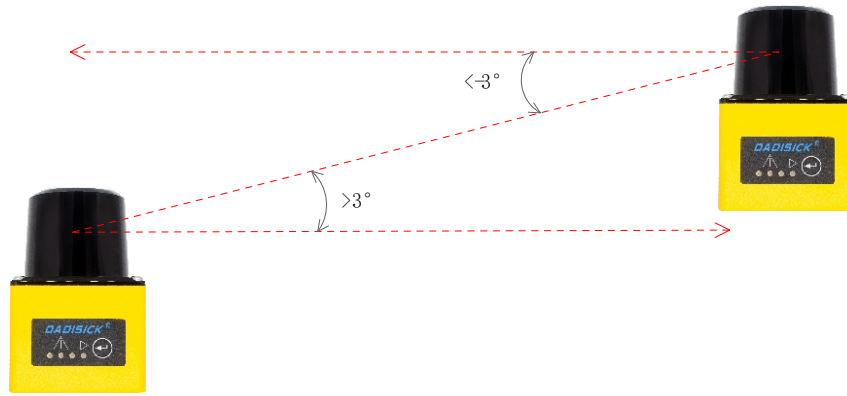

Figure 5-4 Vertical installation

2. Parallel installation

Tilt the radar slightly during installation to avoid mutual interference.

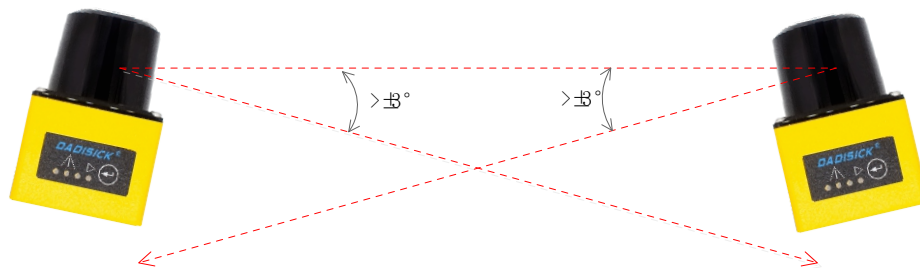

Figure 5-5 Parallel installation

3. Isolated installation

Adding obstructions between radars will prevent laser pulses from being received by other radars, thus avoiding interference.

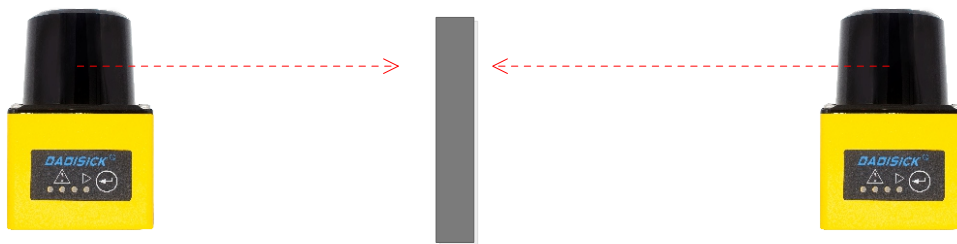

Figure 5-6 Isolated installation

5.5 Electrical connection

5.5.1 Connecting cables

radar provides two electrical connection methods: 15-Pin D-Sub and 1.25mm 12-Pin.

The cable has a diameter of 6mm and a length of 2m.

The meaning of the circuit is shown in the figure:

1	DC 9~28V
2	N.C.
3	N.C.
4	OUT4/ERROR OUT
5	GND
6	OUTPUT_COM-
7	INPUT5/STANDBY
8	INPUT1
9	INPUT2
10	INPUT3
11	INPUT4
12	OUTPUT1
13	OUTPUT2
14	OUTPUT3
15	N.C.

Figure 5-7 15 pin D-sub interface

1.25mm 12-Pin

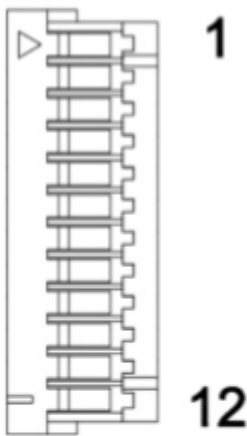

1	INPUT5/STANDBY	BROWN AND WHITE
2	SHIELD	YELLOW AND WHITE
3	OUTPUT_COM-	PINK
4	OUTPUT1	PURPLE
5	OUTPUT2	GRAY
6	OUTPUT3	LIGHT GREEN
7	OUTPUT4	YELLOW
8	N.C.	BROWN
9	INPUT4	ORANGE
10	INPUT3	BLUE
11	INPUT2	WHITE
12	INPUT1	GREEN

Naked wire

VCC	RED
VCC	RED AND WHITE
GND	BLACK
GND	BLUE AND WHITE

Figure 5-8 1.25mm 12 pin interface

The cable is 6mm in diameter and 2m in length.
The meanings of each interface are as follows:

Interface name	function	explain
VCC	Power Supply	DC 9 ~ 28V
GND	Power Supply	Grounding
INPUT1	input	Area selection input bit 1
INPUT2	input	Area selection input bit 2
INPUT3	input	Region selection input bit 3
INPUT4	input	Area selection input bit 4
INPUT5/STANDBY	input	Put the device in standby mode
OUTPUT1	output	When an obstacle is detected in zone 1, this pin and output_ Com short circuit
OUTPUT2	output	When an obstacle is detected in zone 2, this pin and output_ Com short circuit
OUTPUT3	output	When an obstacle is detected in zone 3, this pin and output_ Com short circuit
OUT4/ERROR_OUT	Output / error indication	When a functional failure occurs inside the product, the pin and output_ Com short circuit
SHIELD	shield	Short circuit between wire shield and metal shell
OUTPUT_COM-	Output common negative	Output common negative

5.5.2 input circuit

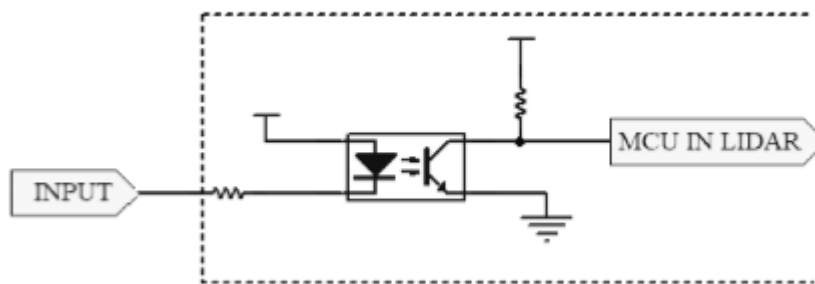

Figure 5-9 input circuit

5.5.3 output circuit

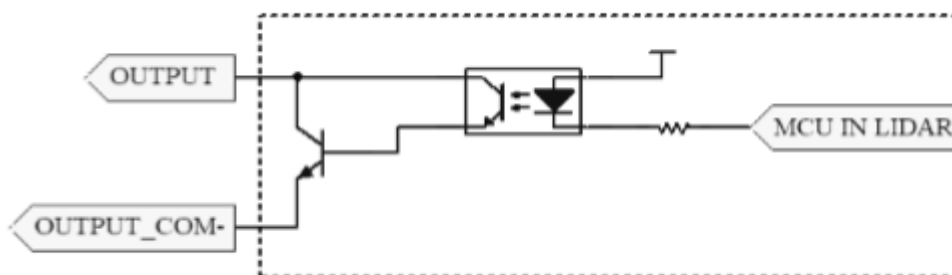

Figure 5-10 output circuit

5.6 Indicator Status

When radar is in different working modes, 4 LED indicators have different meanings, as shown in the table below:

Led	monitor model	Edit mode	Self learning mode	Standby mode
Led4	Abnormal indicator: normally on, once in 1s	Abnormal indicator: normally on, once in 1s	Abnormal indicator: normally on, once in 1s	Flash once in 1s
Led3	Zone 3 intrusion flag, same as out 3(yellow zone)	Always on	Always off	Always on
Led2	Zone 2 intrusion flag, same as out 2 (orange zone)	Always on	Always off	Always on
Led1	Zone 1 intrusion sign, same as Out1 (red zone)	Always on	<p>Enter the self-learning state: Press the button and the LED flashes once every 1 second; Fast flash: Enter fast flash (once in 0.25s, the hand is not released, the hand can be released) means that it can enter the self-learning state (releasing the hand to enter self-learning); Self-learning stage: 60 seconds (60 * 15 circles) always on; End of self-learning: Fast flashing (once every 0.25s) indicates the completion of self-learning and the stage of storing self-learning data.</p>	Always on

6. Typical cases

6.1 Access control

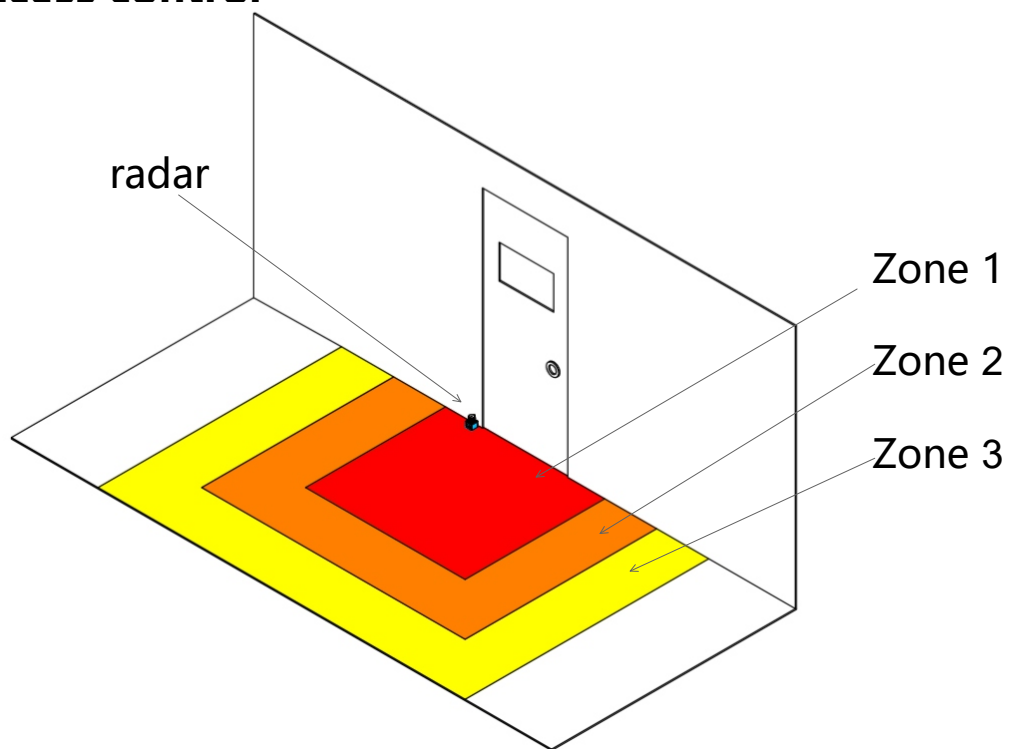

Figure 6-1 Access control

6.2 Detection of protrusions

In this case, radar is installed on the shelf to detect whether there is a cargo intrusion detection plane to prevent the cargo from falling.

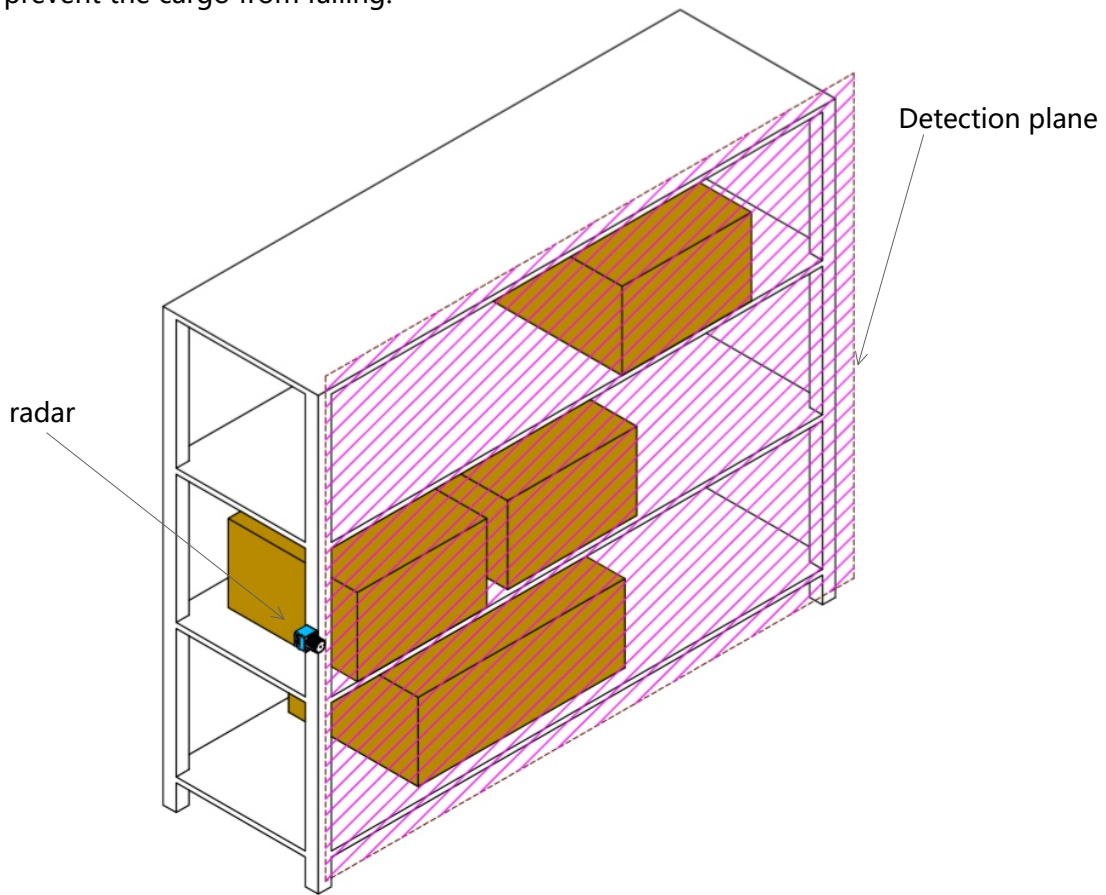

Figure 6-2 Projection detection

Similarly, radar can also be used to detect protrusions on a horizontal surface. Users can configure it according to their needs.

6.3 Area protection

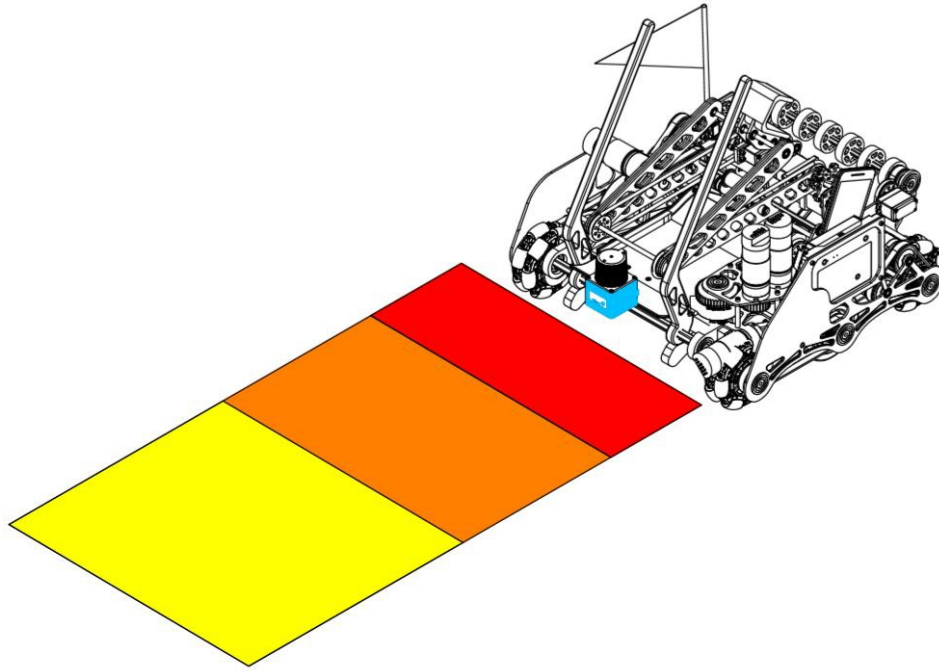

Figure 6-3 Obstacle avoidance trolley

7 Equipment inspection and maintenance

Equipment inspection and maintenance are important for the safe use of equipment. The user must inspect and maintain the equipment as required.

7.1 Review before use

After the equipment is installed and configured, at least the inspections listed in the following table are required before the equipment can be used.

Number	Check item	Whether to pass	Remarks
1	The equipment is correctly installed in the designated location without looseness		
2	All signal cables are properly connected		
3	When the test obstacle enters the defined area, the corresponding signal line is triggered and the corresponding LED light is on		
4	When the test obstacle leaves the designated area, the corresponding signal line fails and the corresponding LED light goes out		
5	When the input signal changes, the corresponding working area also changes		

7.2 Daily inspection

Numbering	Check item	Whether to pass	Remarks
1	The equipment is correctly installed in the designated location without looseness		
2	All signal cables are properly connected		
3	When the test obstacle enters the defined area, the corresponding signal line is triggered and the corresponding LED light is on		
4	When the test obstacle leaves the designated area, the corresponding signal line fails and the corresponding LED light goes out		
5	When the input signal changes, the corresponding working area also changes		
6	The system where the device is located is working normally		

7.3 Occasional inspection

Number	Check item	Whether to pass	Remarks
1	The equipment is correctly installed in the designated location without looseness		
2	The device is still in the original installation position and has not moved		
3	The optical cover of the device is free of dust and scratches		
4	The equipment cable is properly connected		
5	When the input signal changes, the corresponding working area also changes		
6	The system where the device is located is working normally		
7	When the test obstacle enters the defined area, the corresponding signal line is triggered and the corresponding LED light is on		
8	When the test obstacle leaves the designated area, the corresponding signal line fails and the corresponding LED light goes out		
9	When the input signal changes, the corresponding working area also changes		
10	The system where the device is located is working normally		

When the optical cover is covered with dust or oil, the detection ability of radar will be affected, and the user should clean it according to the correct method:

- Wipe with a clean cotton cloth
- Use a soft brush to clean
- Use a hair dryer to blow off the dust
- Use a neutral detergent to remove oil on the surface

8 Product performance parameters

Features	
Laser light source	905 nm (Class I)
Scanning angle range	270°
Scanning frequency	15 Hz/30 Hz
Angle resolution	0.1°/0.3°
Working area	0.05m ~ 5m
Self-learning function	Automatically scan the environment and generate areas
Mechanical / electronic parameters	
Electrical connections	DB15 Male loose wire
Supply voltage	DC 9 V ~ 28 V
Power consumption	2 W
Switch drive	DC30V 50mA MAX
Shell color	light blue
Protection level	IP65
weight	150g, without cable
Dimensions (LxWxH)	50 mm x 50 mm x 76 mm
Performance	
Recognizable object shape	Almost any shape
Measurement error	±30 mm
Number of regional groups	16 regional groups, each regional group contains 3 regions
Interface	
USB	Micro-USB
Digital input	GND/NC * 4
Switch output	NPN * 3, equipment work instructions * 1
Signal output hold time	10 ms ~ 10,000 ms (adjustable) 330ms typical
Response time	15Hz: 67 ms ~ 29,949 ms (adjustable) 134ms typical 30Hz: 33 ms ~ 29,997 ms (adjustable) 66ms typical
Status Indicator	Power indicator * 1, status indicator * 4
Environmental parameters	
Anti-vibration	10-55Hz, amplitude 0.75mm, XYZ triaxial, 2 hours per axis; 50-200Hz, 196m / s ² (20G), scanning speed 2min / cycle, XYZ triaxial, 2 hours per axis
Working temperature	-10 °C ~ +55°C
Storage temperature range	-30 °C ~ +75 °C
Ability to resist ambient light	<15,000 lux

DADISICK[®]

WhatsApp/WeChat/Tel: **+86 13713346108**

Email: **sale@dadisick.com**

Website: **www.dadisick.com**



DADISICK TECHNOLOGY LIMITED

No.33 Sanjiang Industrial Area, Hengli Town,
Dongguan City, Guangdong Province P.R.China.