

**DADISICK®**

# Long distance laser rangefinder DK-DS series



# 1

## Product Introduction

DADISICK's new long-distance laser rangefinder DK-DS series can achieve high-precision fixed-point measurement within 200 meters, with a ranging accuracy of up to  $\pm 2\text{mm}$ ; the DK-DS series is equipped with an intuitive operation panel and status prompts, which can be easily and quickly installed: Unlike conventional phase rangefinders, this product can support a measurement frequency of up to 1000Hz, so it is particularly suitable for precise positioning and measurement of high-speed moving objects, and is an essential sensor for automated warehousing, logistics or driving systems.



**200m**  
Measuring  
Distance



**1000Hz**  
Measurement  
frequency



**2mm**  
Distance measurement  
accuracy



**Easy**  
Installation

Basic information			
Product name	Long distance laser rangefinder DK-DS series		
Model	DK-DS-80	DK-DS-120	DK-DS-200
Measurement characteristics			
Measurement range (reflective film)	80m	120m	200m
Typical value of spot size	100mm (@80m)	150mm (@120m)	245mm (@200m)
Measurement accuracy	±2 mm		
Repeat accuracy	1 mm		
Measurement frequency	1000Hz		
Measurement resolution	0.1mm		
Maximum movement rate	15m/s		
Optoelectronic characteristics			
Power supply voltage	DC 9V...30V		
Working current	0.2 A/12V DC		
Laser source	Red laser (visible light)		
Power consumption	2.4W(MAX)		
Others			
Data transmission interface	SSI、Ethernet100BASE-TX		
Indicator light	PWR indicator, MF1/MF2 status, LNK indicator, BUS indicator		
Display screen	OLED screen (128*64 pixels)		
Network interface	M12/4-core/D-type female straight connector		
Power supply/SSI interface	M12/8-core/A-type male straight connector		
Ambient light resistance	≤100,000 lx		
Working environment temperature	-10°C ~ +55°C		
Storage temperature	-30°C ~ +75°C		
Humidity	< 80%		
Protection level	IP65		
Dimensions	123*69.5*90 (mm)		
Weight	600g (without wire)		

# 3

# Software

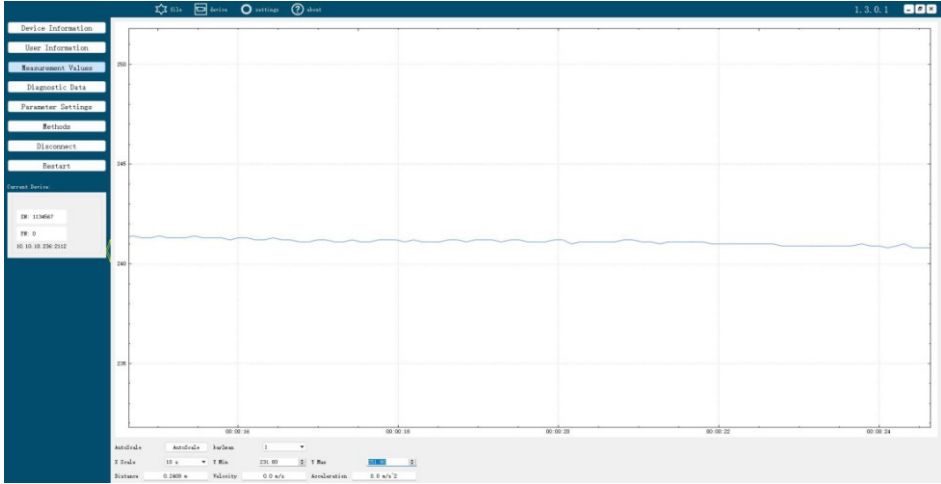

# 4

# Dimension

Unit: mm

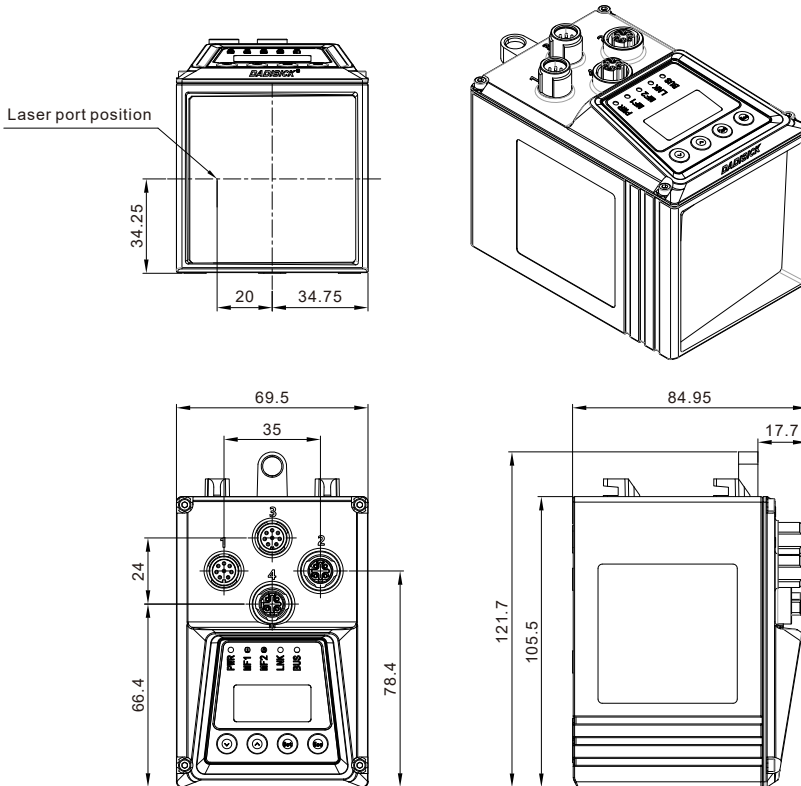



Smart warehousing



Lifting or hoisting equipment



Automated parking system



Port automation

**DADISICK**



Scan the QR code to learn more

## Contact us

### **DADISICK TECHNOLOGY LIMITED**

Add: No.33 Sanjiang Industrial Area, Hengli Town, Dongguan City, Guangdong Province P.R.China.  
We reserve the right to make technical changes

Email: [sale@dadisick.com](mailto:sale@dadisick.com)  
WhatsAPP: 86 13313746108  
Website: [www.dadisick.com](http://www.dadisick.com)