

TECHNICAL DATA SHEET

LASER RANGING SENSOR DK-DA-Y & DK-DB-Y series



Figure can vary

Contents

- Product Features
- Application Scenario
- Model Selection
- Circuit wiring diagram
- Size parameter
- Installation instructions



DK-DA-Y & DK-DB-Y series

Product description

DK-DA-Y/DK-DB-Y series industrial-grade laser sensors provide accurate and stable distance measurement and can be integrated into various industrial applications. The red laser beam hits the reflective surface and non-contact measurement is performed based on the return signal.

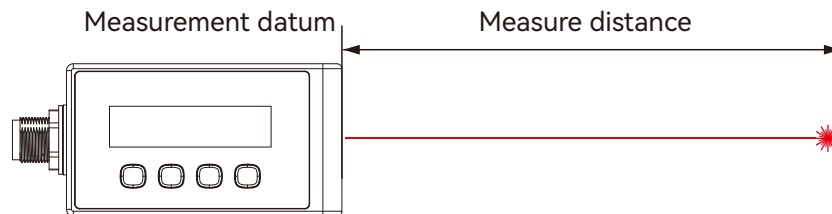

Features

- ⊙ Phase method distance measurement, high accuracy and fast speed;
- ⊙ It comes with a screen and built-in menu, and can be set up without connecting to a computer;
- ⊙ Output interface:
RS232/RS485, 2 switching outputs plus voltage/current output;
- ⊙ Supports 64 units online networking and PLC programming;
- ⊙ IP67 protective metal die-cast body ensures stability even outdoors and in harsh environments.

Application Cases

- ◇ Industrial measurement of position, displacement, thickness, distance, etc.
- ◇ Industrial automation and production intelligent management
- ◇ High-altitude cable erection measurement, railway catenary measurement
- ◇ Material level/liquid level detection
- ◇ Slope and dam deformation monitoring
- ◇ Building security monitoring



Industrial automation and intelligent production management

Displacement/distance measurement

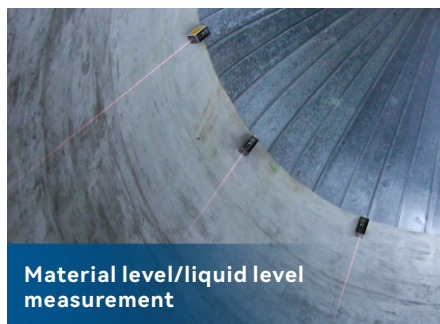

Material level/liquid level measurement

40Hz high-frequency fast refresh



Production safety monitoring

Multiple outputs can be connected to alarms

Technical Parameters

Item	Type A				
Model	DK-DA-Y10	DK-DA-Y20	DK-DA-Y30	DK-DA-Y50	DK-DA-Y100
Measuring distance	0.2-10m	0.2-20m	0.2-30m	0.2-50m	0.2-100m
Voltage/current output	/				
Voltage output error	/				
Current output error	/				
Output mode	Digital quantity+switch quantity				

Item	Type B (With voltage and current output)				
Model	DK-DB-Y10	DK-DB-Y20	DK-DB-Y30	DK-DB-Y50	DK-DB-Y100
Measuring distance	0.2-10m	0.2-20m	0.2-30m	0.2-50m	0.2-100m
Voltage/current output	Can be set to 0~5V / 0~10V / 4~20mA / 0~20mA / 0~24mA output *Note 2				
Voltage output error	0.2%+0.5mV				
Current output error	0.2%+0.005mA				
Output mode	Digital quantity+switch quantity+analog quantity				

Communication interface	RS232/RS485 (switchable)
Measuring frequency	1Hz-40Hz
Laser type	Class II, 660±15nm, ≤1mW
Measurement resolution	1mm
Measurement error	±(2mm+d * one ten thousandth) *Note 1
Indicator light	Red laser
Spot size	@1m∅6mm;@10m∅8mm; @20m∅12mm;@30m∅16mm;
Display	128x32 dot matrix screen
Backlight off time	30 minutes (can be set to normally on)
Operating mode	Off measurement, continuous measurement
Transistor switch output	2 channels (cannot exceed DC36V 0.5A) *Note 3
Power supply	DC15~30V
Power consumption	< 3.0W
Protection grade	IP67
Shell material	Die-cast zinc alloy
Working temperature	-10°C~50°C
Storage temperature and humidity	-20°C~60°C, 20%~85%RH
Overheating protection	When the body temperature is higher than 70°C, the measurement will be shut down and when the temperature is lower than 70°C, the measurement will be resumed
Body size	88.45x40x59.3mm (including connection base)

***Note 1:** When [Speed Level] is 1.

“d” represents the actual distance. In harsh environments, such as when the sun is too strong and the ambient temperature fluctuates too much, there will be a large error in the measurement results. In this case, the effect is better when used with a target reflector.

***Note 2:** Current and voltage can't be output at the same time.

***Note 3:** If the external DC output of the transistor switch exceeds the limited voltage or current, it may cause permanent damage to the instrument.

Display and Buttons

• Display

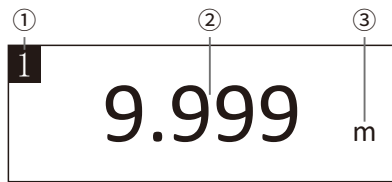

- ① Station number
- ② Measuring distance
- ③ Unit of measurement distance

• Buttons

Button	Press	Hold
	Confirm in setting mode	Enter parameter setting mode
	Return to setting mode	Backlight switch setting
	Adjust option content	Adjust position forward
	Adjust option content	Adjust position backward

Installation Dimensions

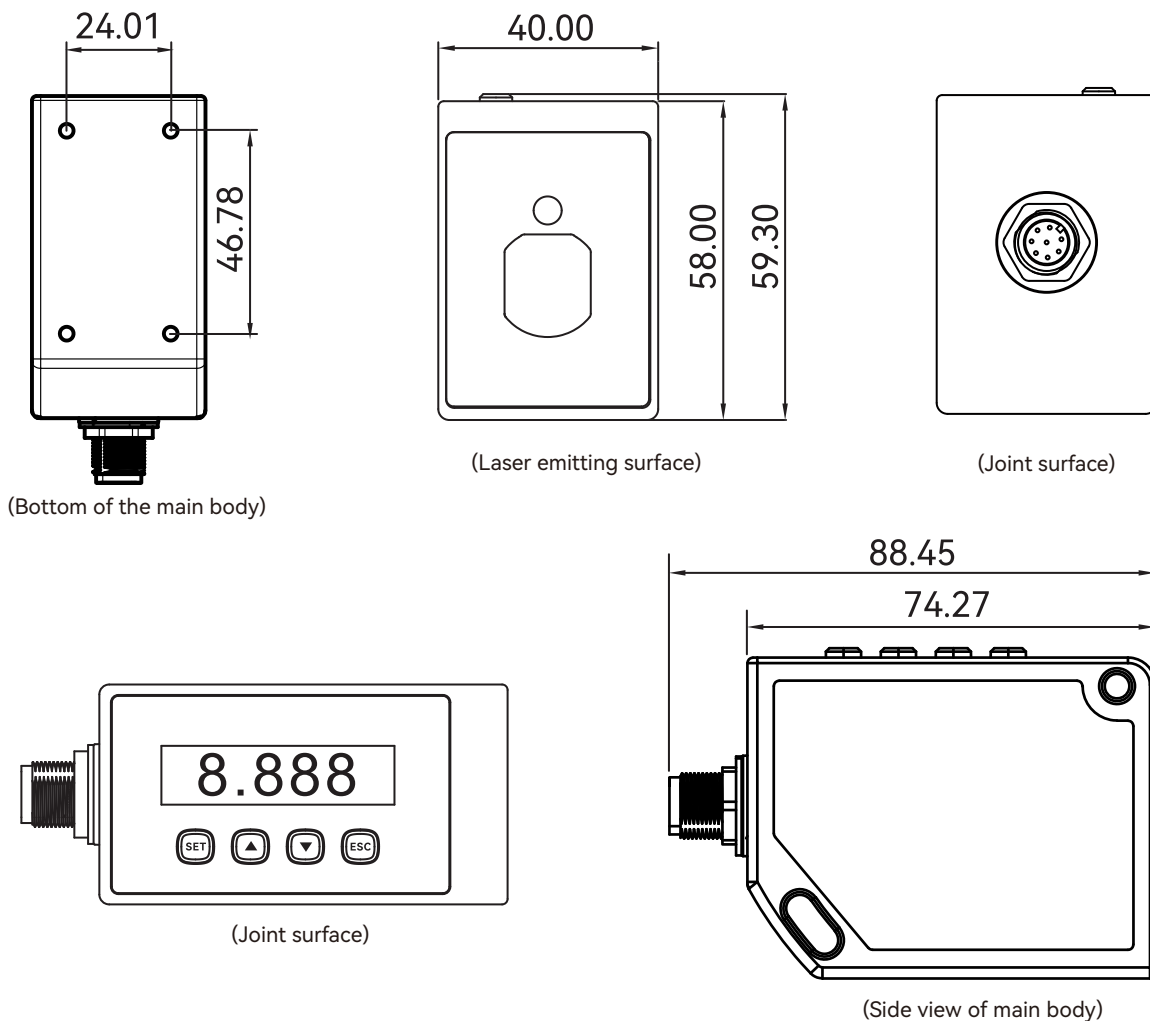

3.RS232 Wiring Method

This function has an open-drain (collector) output inside the instrument. It can only input DC current and cannot directly output voltage and current. Please note that the current sink cannot exceed DC36V 0.5A.

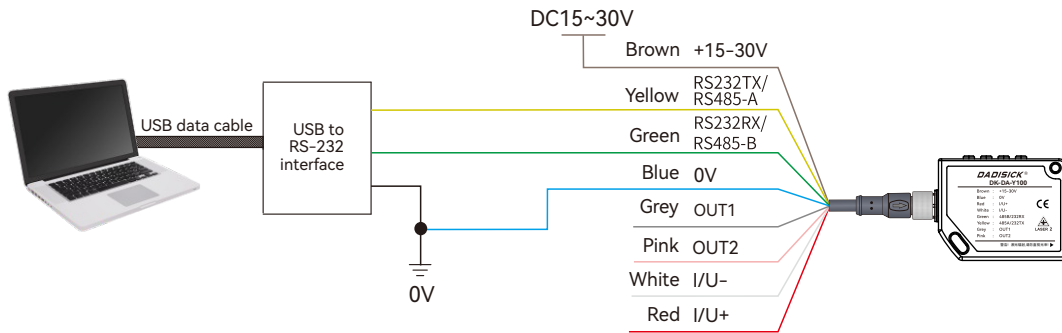

Note: RXD and TXD on the computer side and instrument side need to be cross-connected.
RS232 has three connections: RX (green) TX (yellow) GND (blue).

D-Sub connector RS232 pin definition

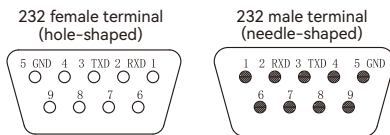

4.RS485 networking connection method

This function has an open-drain (collector) output inside the instrument. It can only input DC current and For example, the figure below is a connection diagram for networking a computer and multiple instruments through RS485 half-duplex communication, All instruments are connected to the bus, Due to address restrictions, the maximum number is 64.

Note: In actual application, if communication is unstable, a 120Ω /8W resistor needs to be connected in parallel to the RS485 terminal.

