

USER'S MANUAL

SAFETY LIGHT CURTAIN SENSOR Emitter and Receiver DK-QM series

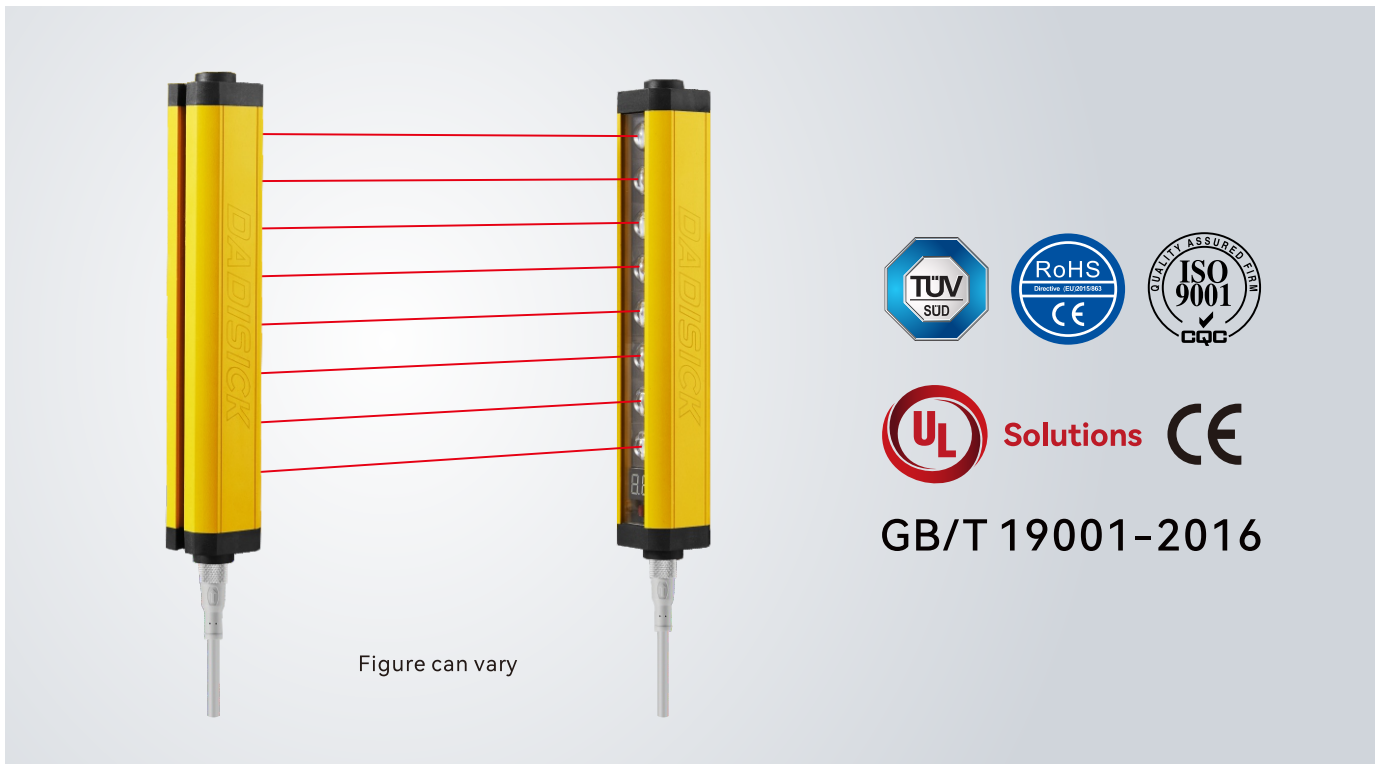

Thank you very much for purchasing DADISICK products!

Please be familiar with the user manual and product manual before use.

For your safety, please be sure to follow the precautions in the safety precautions.

Please be sure to follow the instructions, product manual, DADISICK website, and other precautions.

Please keep it properly for easy retrieval.

The specifications and external dimensions recorded in this manual are subject to change or discontinuation due to product improvements without prior notice.

Please confirm the latest information on the DADISICK website.

SAFETY CONSIDERATIONS

- Observe all 'Safety Considerations' for safe and proper operation to avoid hazards.
- ⚠ Symbol indicates caution due to special circumstances in which hazards may occur.

⚠ Warning Failure to follow instructions may result in serious injury or death.

01. Fail-safe device must be installed when using the unit with machinery that may cause serious injury or substantial economic loss. (e.g. nuclear power control, medical equipment, ships, vehicles, railways, aircraft, combustion apparatus, safety equipment, crime/disaster prevention devices, etc.)
Failure to follow this instruction may result in personal injury, economic loss or fire.
02. Do not use the unit in the place where flammable/explosive/corrosive gas, high humidity, direct sunlight, radiant heat, vibration, impact, or salinity may be present.
Failure to follow this instruction may result in explosion or fire.
03. Do not connect, repair, or inspect the unit while connected to a power source.
Failure to follow this instruction may result in fire.
04. Check 'Connections' before wiring.
Failure to follow this instruction may result in fire.
05. Do not disassemble or modify the unit.
Failure to follow this instruction may result in fire.

⚠ Warning Failure to follow instructions may result in serious injury or death.

01. Fail-safe device must be installed when using the unit with machinery that may cause serious injury or substantial economic loss. (e.g. nuclear power control, medical equipment, ships, vehicles, railways, aircraft, combustion apparatus, safety equipment, crime/disaster prevention devices, etc.)
Failure to follow this instruction may result in personal injury, economic loss or fire.
02. Do not use the unit in the place where flammable/explosive/corrosive gas, high humidity, direct sunlight, radiant heat, vibration, impact, or salinity may be present.
Failure to follow this instruction may result in explosion or fire.
03. Do not connect, repair, or inspect the unit while connected to a power source.
Failure to follow this instruction may result in fire.
04. Check 'Connections' before wiring.
Failure to follow this instruction may result in fire.
05. Do not disassemble or modify the unit.
Failure to follow this instruction may result in fire.

⚠ Caution Failure to follow instructions may result in injury or product damage.





01. Use the unit within the rated specifications.
Failure to follow this instruction may result in fire or product damage.
02. Use a dry cloth to clean the unit, and do not use water or organic solvent.
Failure to follow this instruction may result in fire.
03. Do not use a load over the range of rated relay specification.
Failure to follow this instruction may result in fire, relay broken, contact melt, insulation failure or contact failure.

CAUTIONS DURING USE

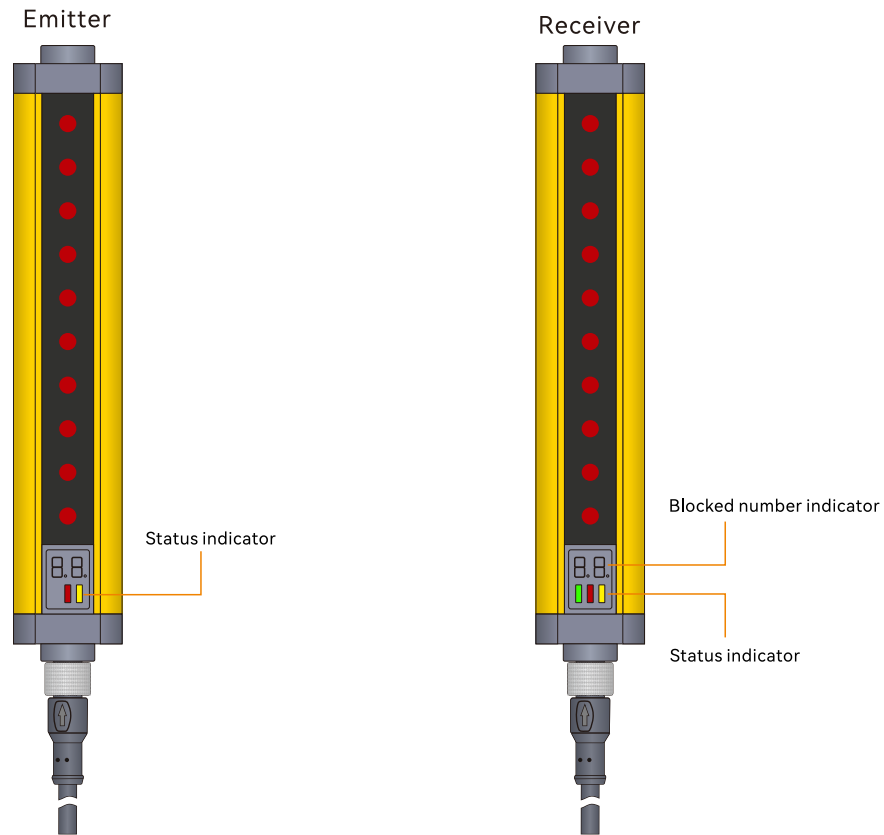
- Follow instructions in 'Cautions during Use'. Otherwise, It may cause unexpected accidents.
- 12 – 24 VDC power supply should be insulated and limited voltage/current or Class 2, SELV power supply device.
- Use the product, 1 sec after supplying power. When using separate power supply for the sensor and load, supply power to sensor first.
- When using switching mode power supply to supply the power, ground FG. terminal and connect a condenser between 0 V and FG. terminal to remove noise.
- When connecting a DC relay or other inductive load, remove surge by using diodes or varistors.
- Wire as short as possible and keep away from high voltage lines or power lines, to prevent surge and inductive noise.
- This unit may be used in the following environments.
 - Indoors (in the environment condition rated in 'Specifications')
 - Altitude max. 2,000 m
 - Pollution degree 2
 - Installation category II

Operation and display



Status indicator	LED status Indicator	Explain
Emitter	 Red and Yellow, always on	Turns on the power
Receiver	 Red, always on	Turns on the power
	 Green and Red	All light paths are connected
	 Red and Yellow	The light is blocked or misaligned
	 Lights flashing	Interference or overstep detection range

Dimensioned drawings

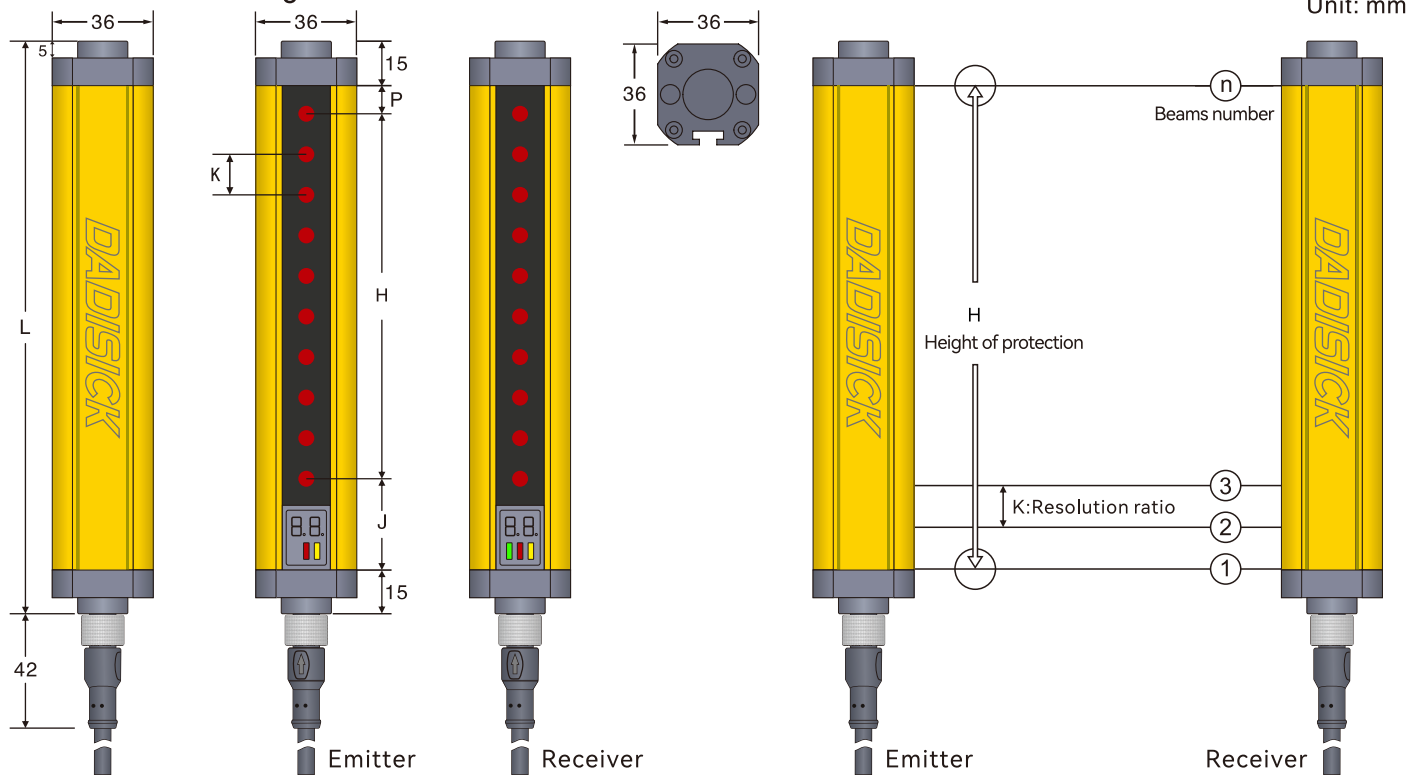

Unit: mm

Remarks L: Total length of light screen H: Height of protected area K: Resolution ratio
 n: Beams number L = P + H + J + 15 + 15 H = (n - 1) * K

K (mm)	2.5	5	10	20	40	80
P (mm)	1.25	2.5	5	10	10	10
J (mm)	25.75	27	29.5	34	34	34

1. DK-QM signal output selection (actual output of transistor working normally)

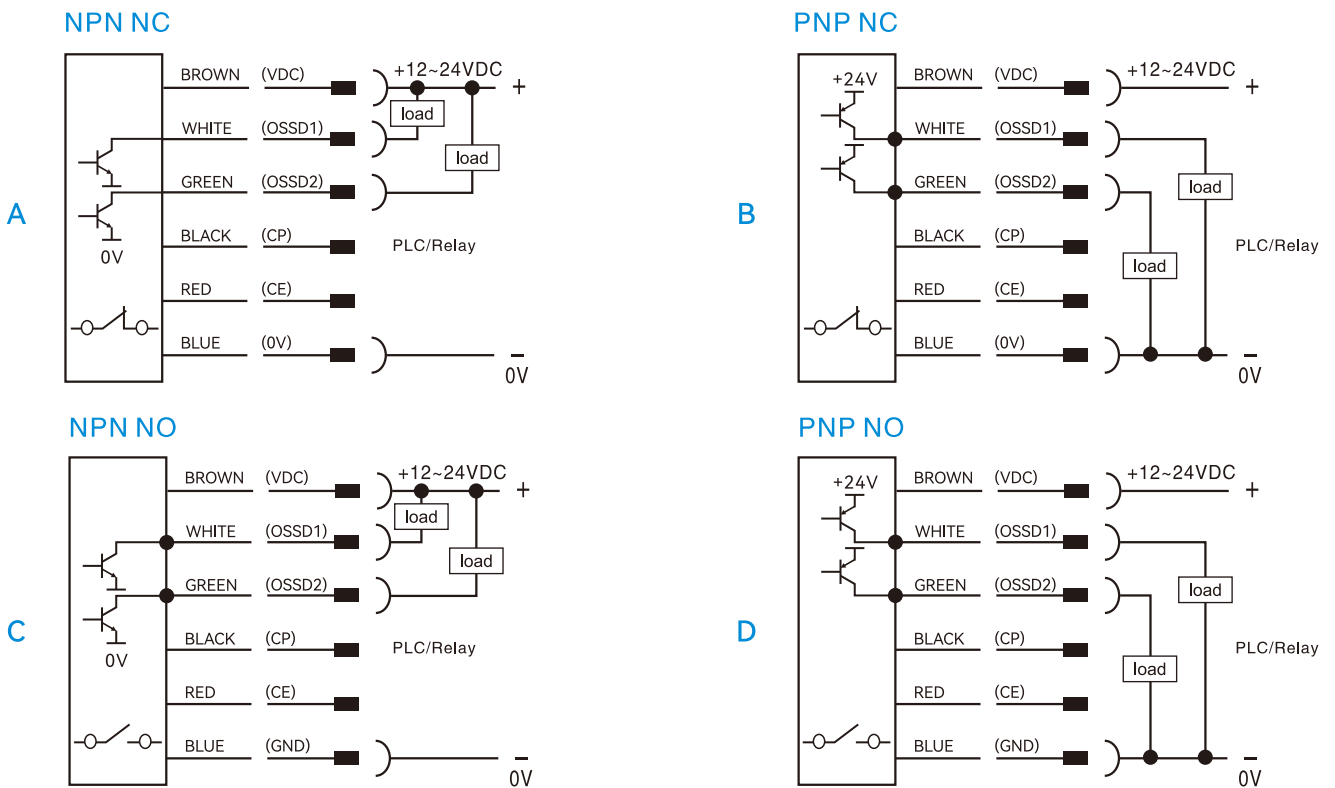



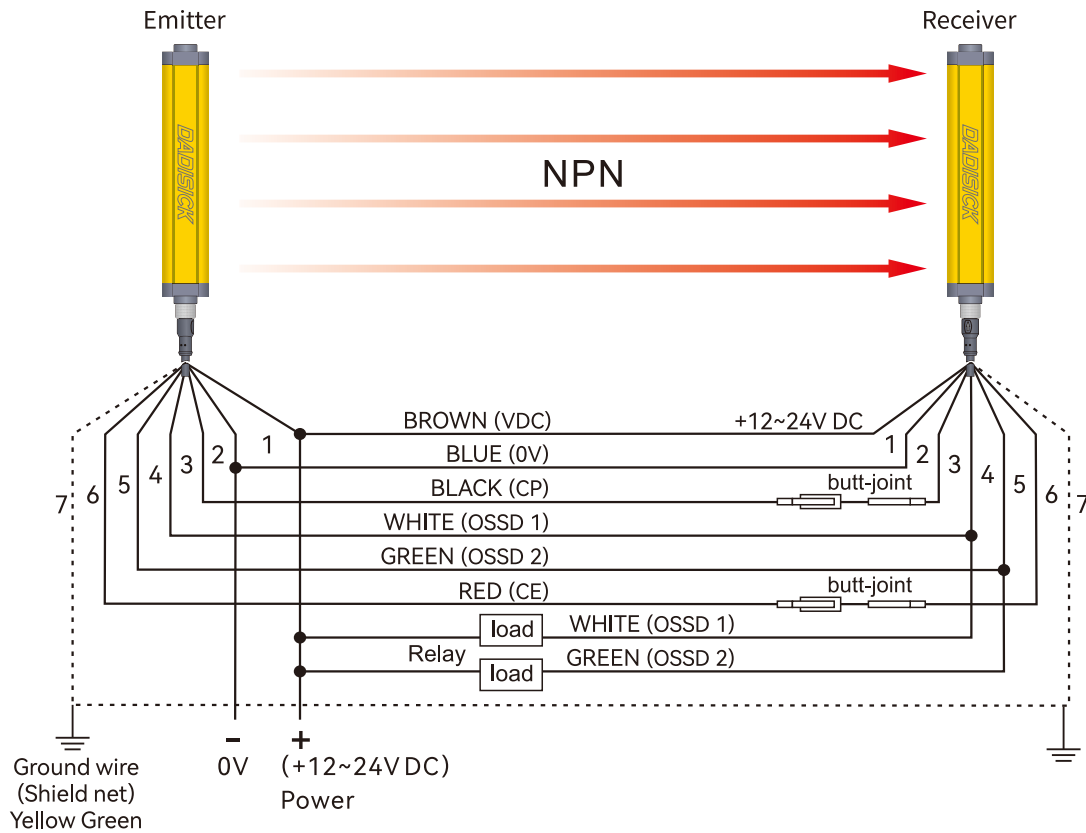

2. NPN output wiring diagram

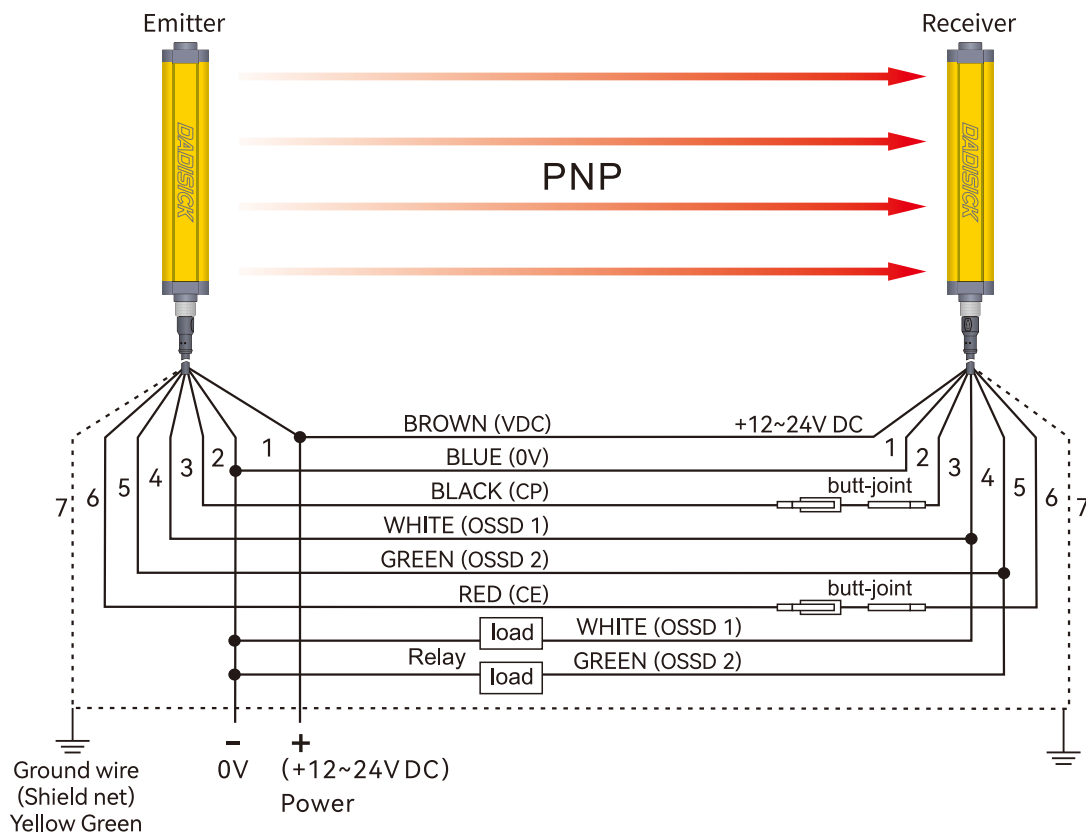

3. PNP output wiring diagram



4. Selection of safety light curtain controller

Name	Order separately	Model	Descriptions
Built-in controller		QET	Used to monitor the signal processing of DK-QM series light curtain, and output one group of NO and one group of NC.
Safety relay		DK-QSRP	DK-QSRP safety relays have three groups of NO and one group of NC, with strong control capabilities. They are suitable for various signal monitoring in industrial places with high safety requirements, including emergency stop signals, safety door opening and closing signals, safety light curtain signals, and two-handed button signals.
Safety relay		DK-Ter-AP	Equipped with a mode switch, it can be used for most safety components, such as light curtains, safety switches, carpet contacts, two handed switches, etc. Automatic/manual reset paddles for quick configuration. Dual channel monitoring circuit, safe and reliable.
Light curtain relay		QET-1	Output conversion between NC and NO for DK-QM series light curtain.

4.1 Wiring diagram of QET built-in controller

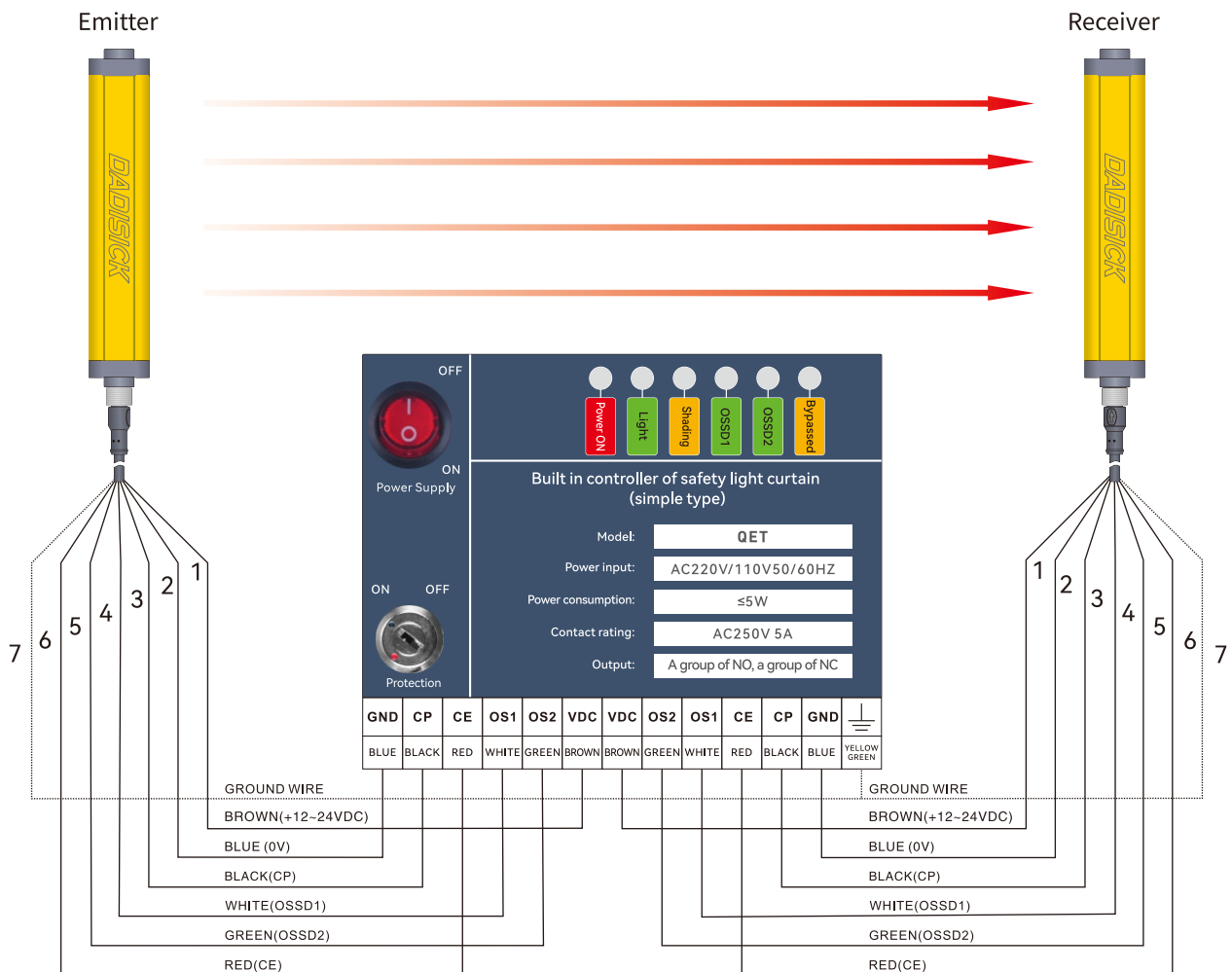

4.2 Wiring diagram of DK-QSRP safety relay

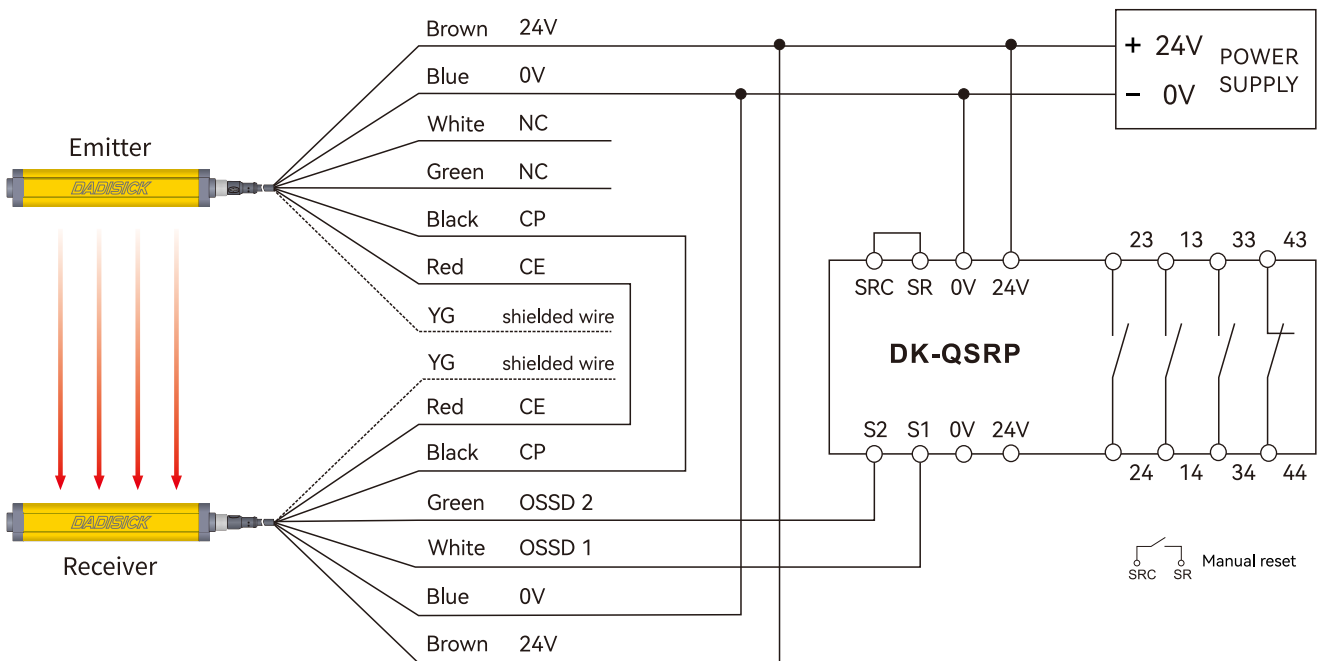

4.3 Wiring diagram of DK-Ter-AP safety relay

Dual channel light curtain PNP switch safety input, with automatic reset and PLC signal output.

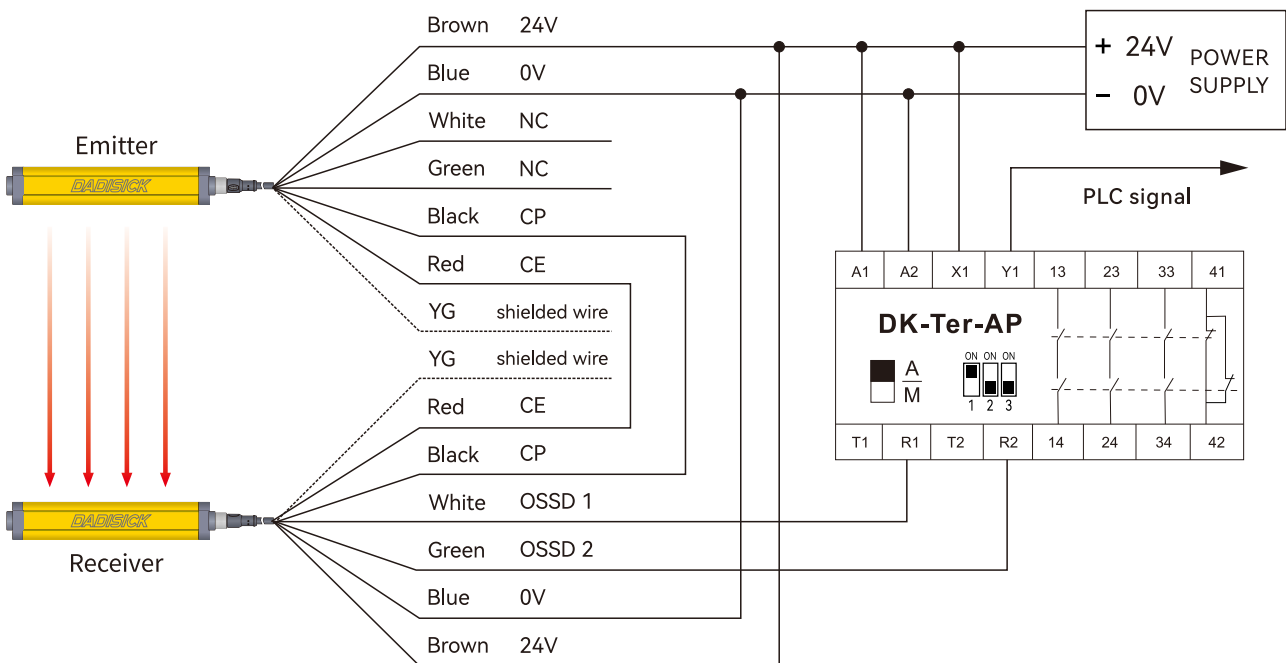

4.4 Wiring diagram of QET-1 light curtain relay

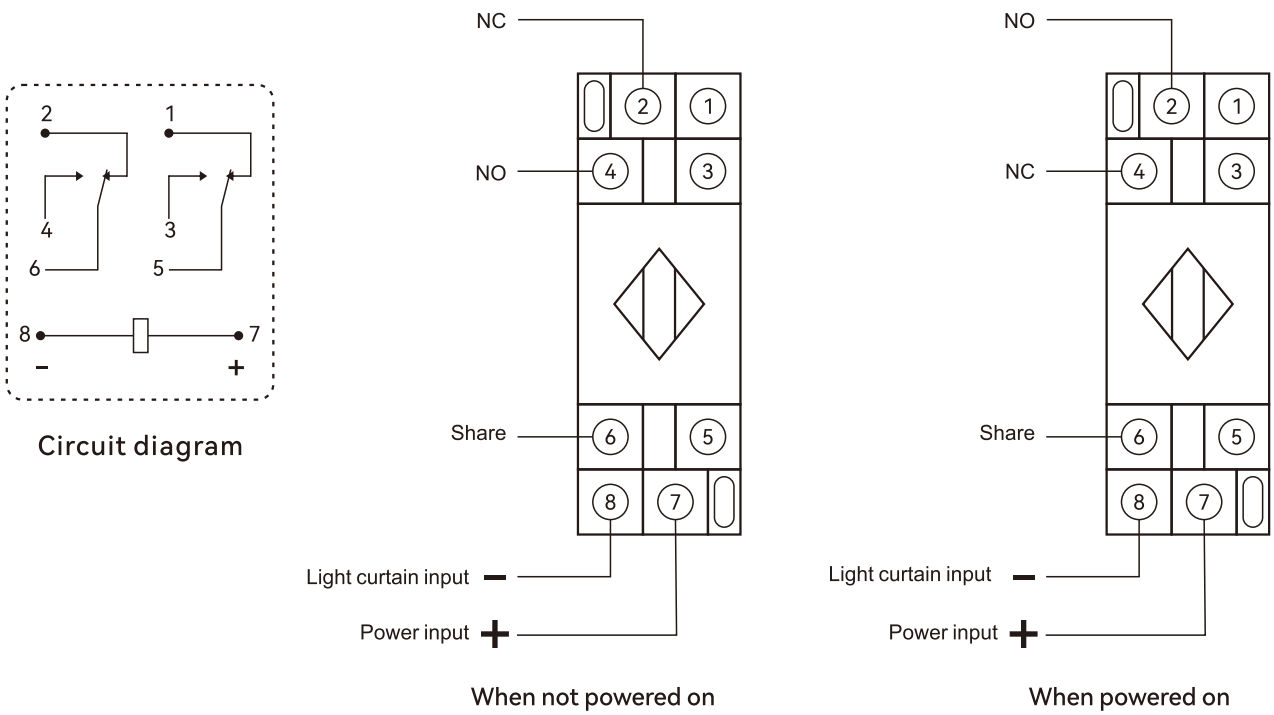

4.5 Wiring between light curtain and PLC and one-chip computer system

NPN wiring:

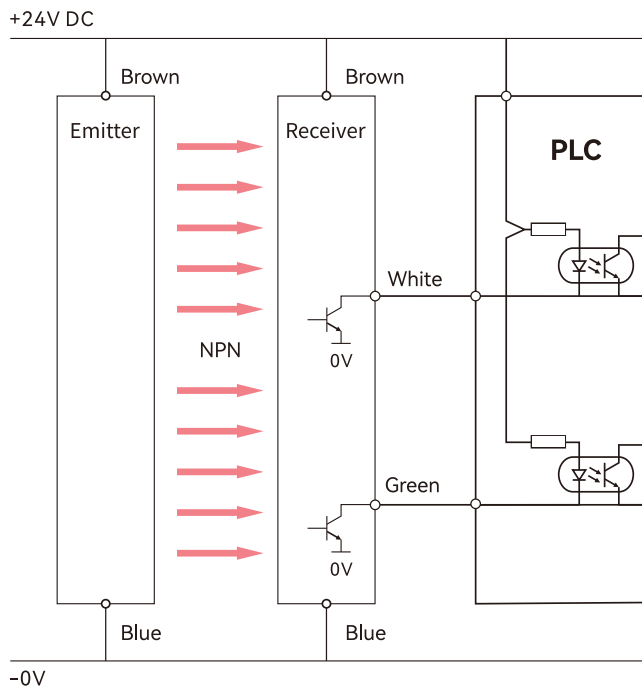

PNP wiring:

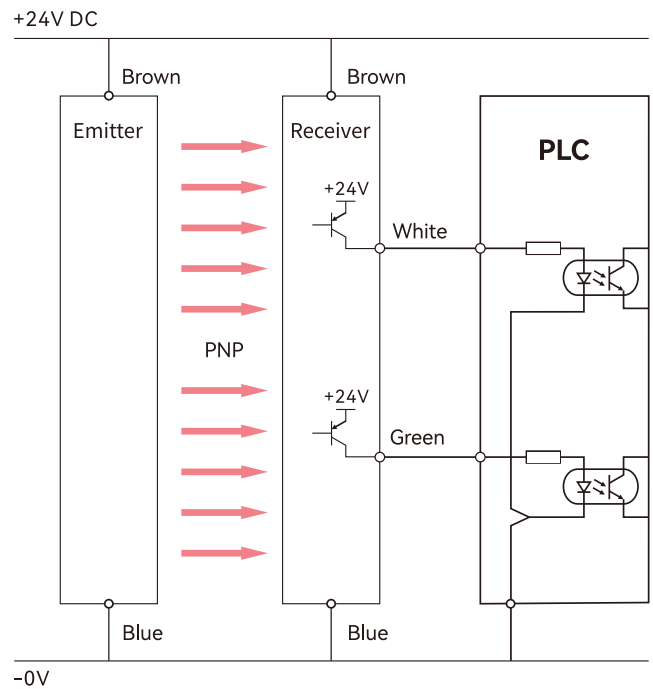

Accessories

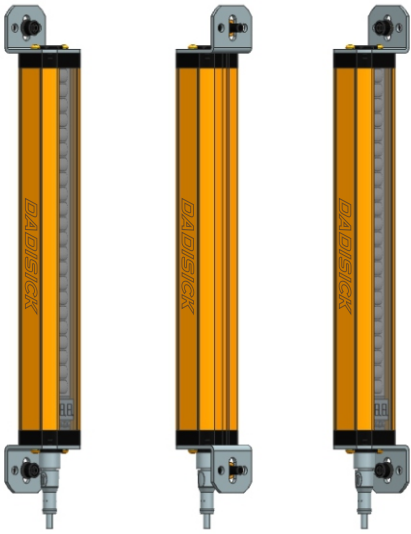

1. Installation of right angle brackets at both ends
(Original accessories)

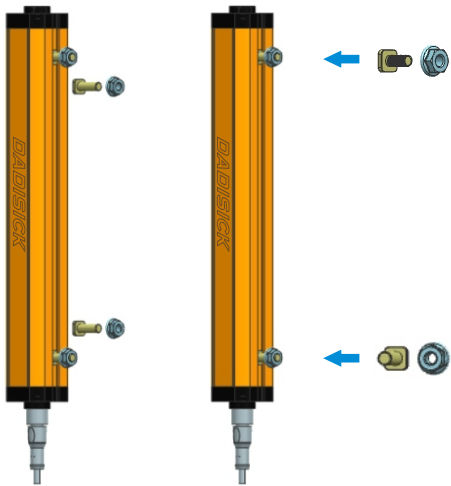
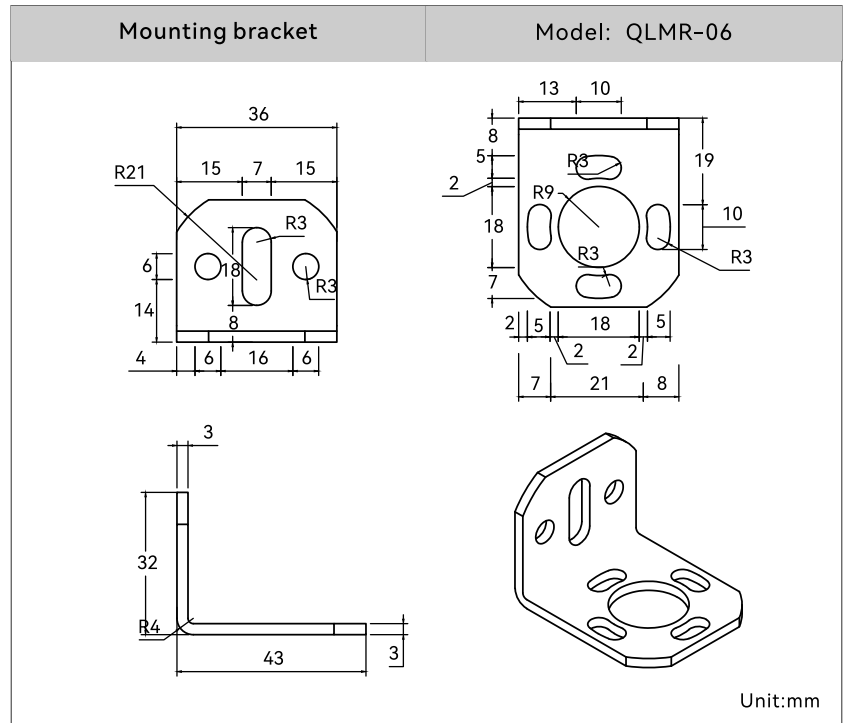

2. Installation method of T-shaped screws on the back
(Original accessories)

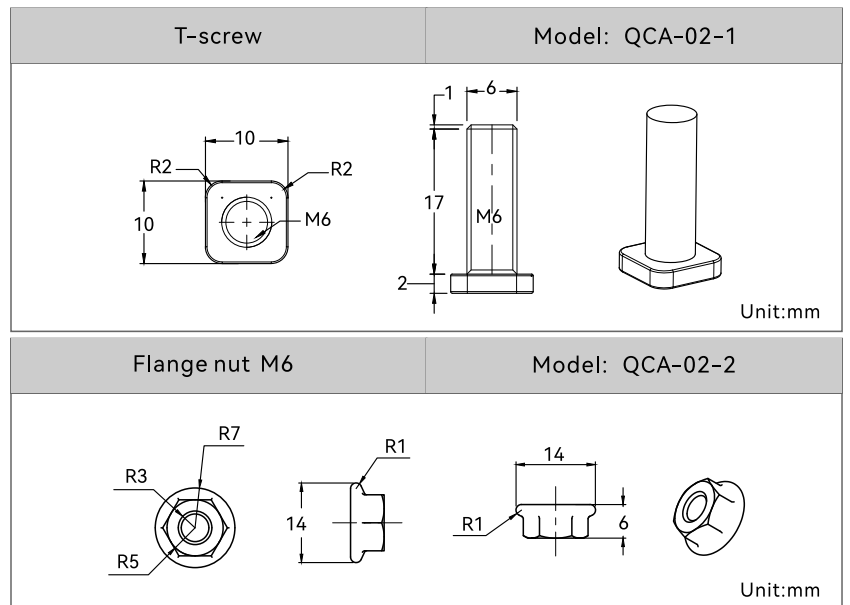

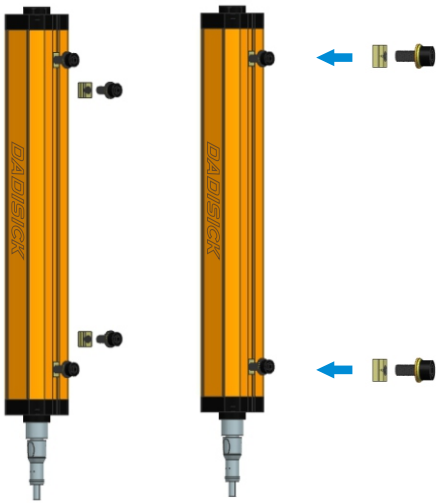

3. Installation method of convex nut
(Optional accessories)

Raised nut	Model: QCA-03-1
	<p style="text-align: right;">Unit:mm</p>
M5 screw	Model: QCA-03-2
	<p style="text-align: right;">Unit:mm</p>

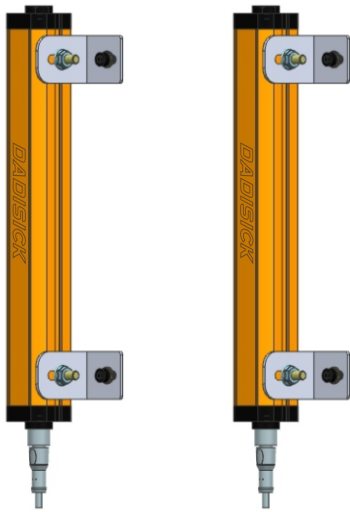

4. Installation method of side right angle bracket
(Optional accessories)

Side mounting bracket	Model: QCA-05
	<p style="text-align: right;">Unit:mm</p>

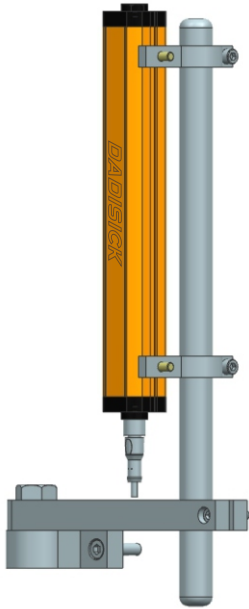

5. Stainless steel bracket installation
(Order separately)

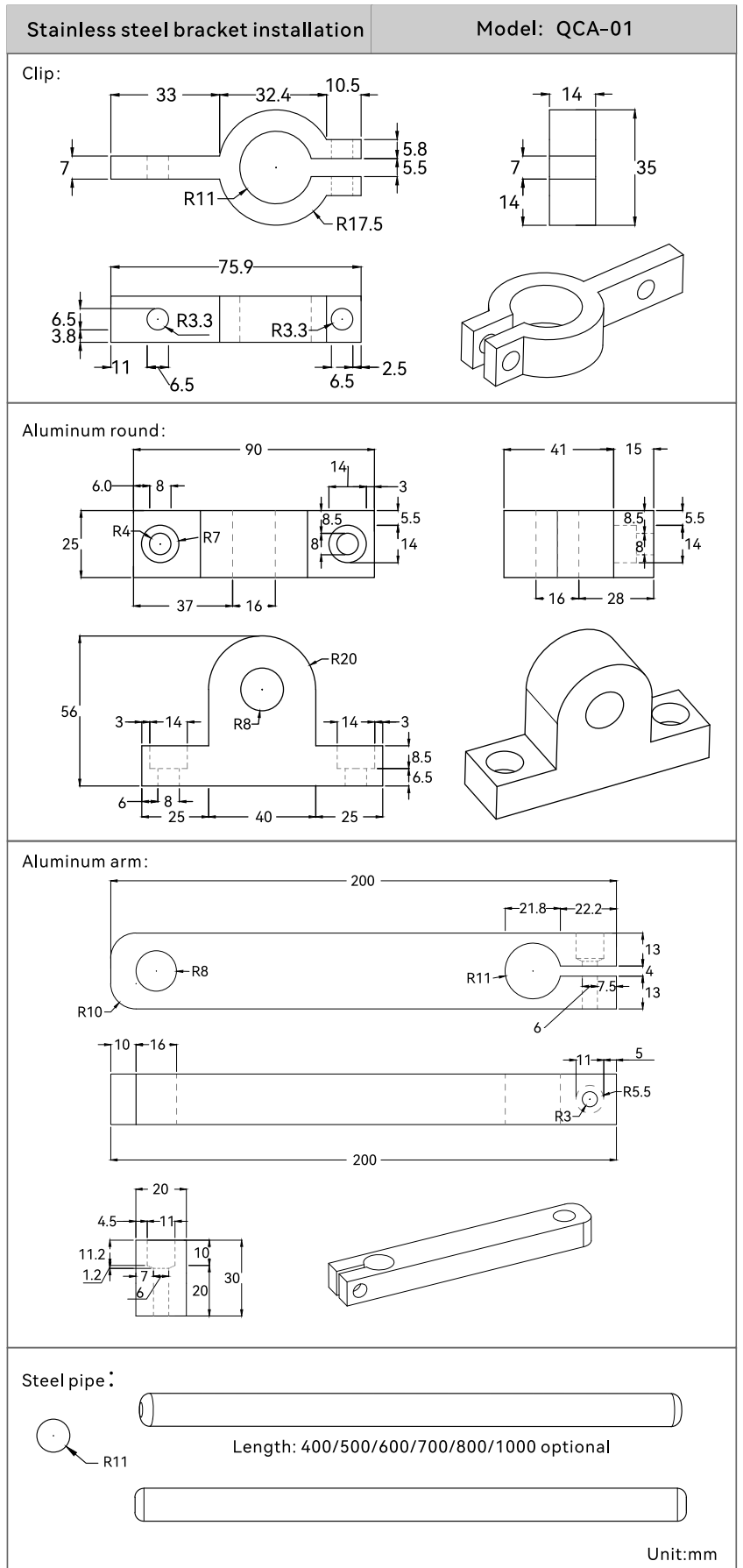

INSTALL

WARNING

Before installation, please open the packing box first, check the packed components according to the packing list, and turn off the power supply of the machine tool at the beginning of installation to avoid danger.

1、 Installation direction

The installation direction of the light emitting device and the light receiving device should be consistent.

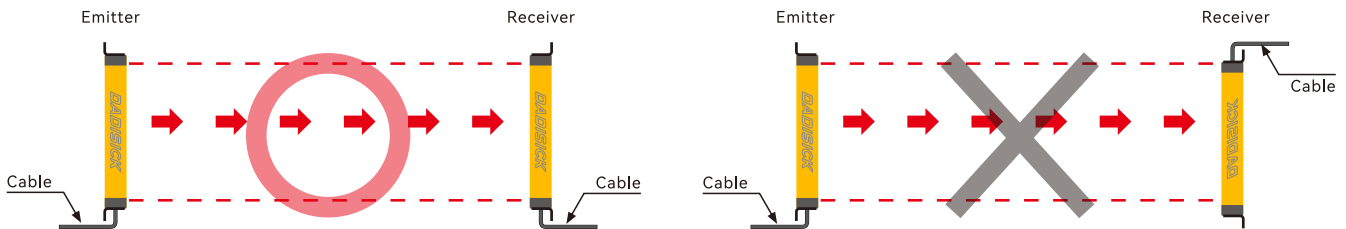

2、 Reflection from the ground and walls

When installing it as below, the light reflected from the surface of wall and flat is not shaded. Please check whether it operates normally or not with a sensing target before using. (interval distance: ≥ 0.5 m)

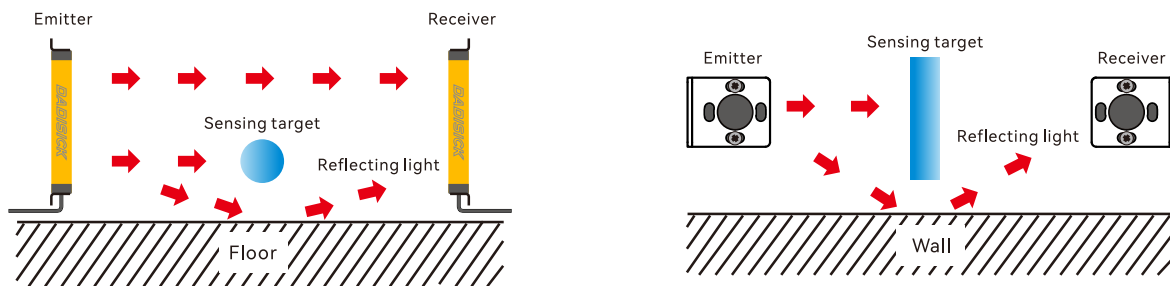

3、 For protection of interference

It may cause interference when installing more than 2 sets of the sensor. In order to avoid the interference of the sensor, please install as following figures and use the transmitted light frequency changing function.

- Transmission direction should be opposite between 2 sets.

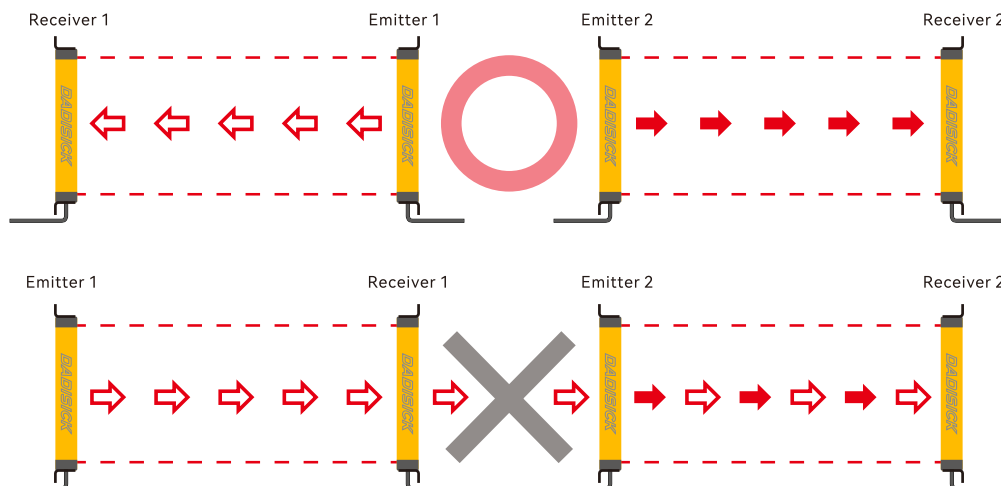

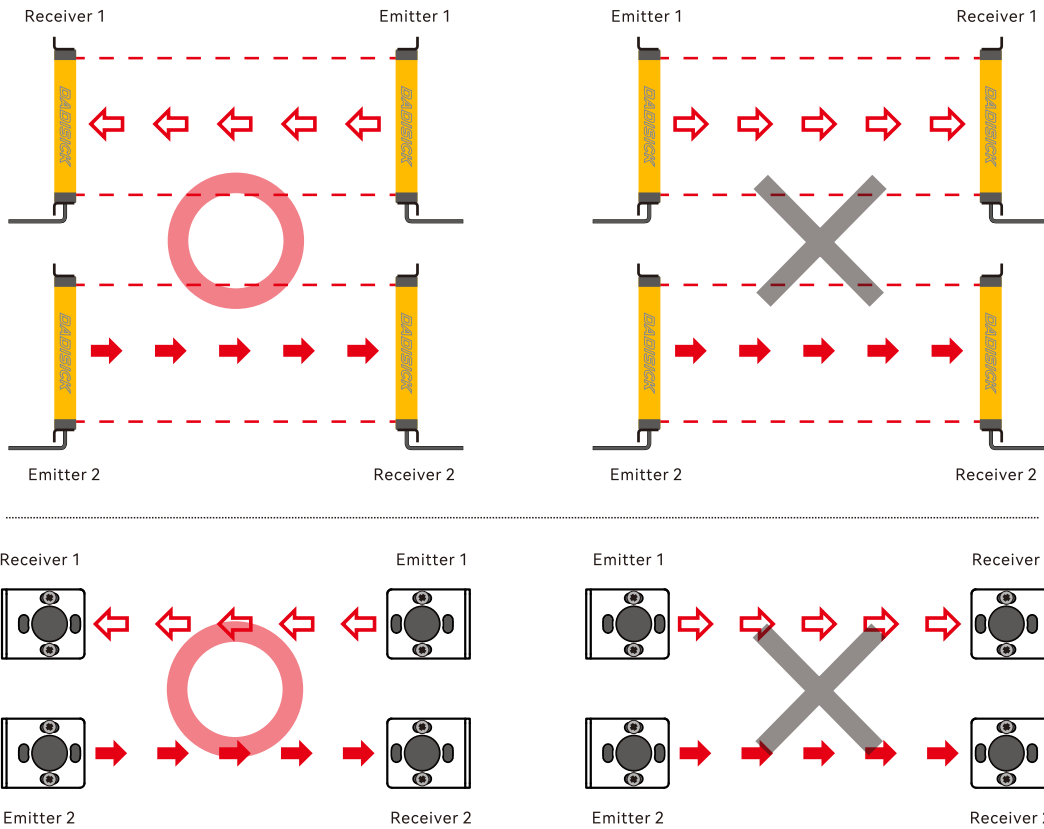

- Baffle should be installed between 2 sets.

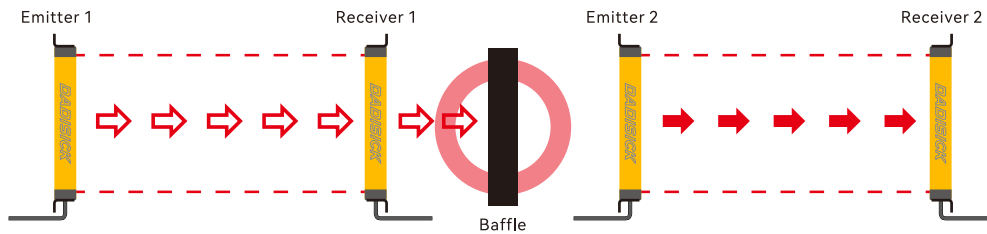

- Interval distance adjustment:

- ① Depending on the environment, it may vary;
- ② Do not use it directly under high-speed and high-frequency fluorescent lamps.

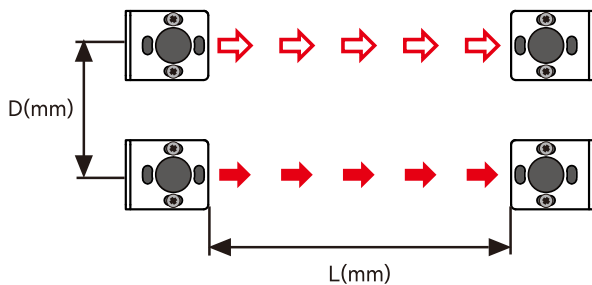

L (sensing distance)	L (installation allowable distance)
0.1~1m	≥0.1m
≥1m	≥0.2m

! WARNING

Safety distance is one of the necessary conditions to ensure that the photoelectric protection device realizes the protection function, the safety distance must be calculated correctly, and the safety distance must be ensured during installation!

1、 the determination of height position

The height position refers to the position of the light curtain of the photoelectric protection device relative to the upper and lower die ports of the machine tool, that is, under the premise of ensuring a safe distance, the lowest beam of light of the photoelectric protection device shall not be higher than the lower edge of the lower die mouth, and the top beam of light shall not be lower than the upper edge of the upper die port.

This involves the selection of the protection height of the photoelectric protection device
 Protection height \geq machine slide stroke + adjustment amount

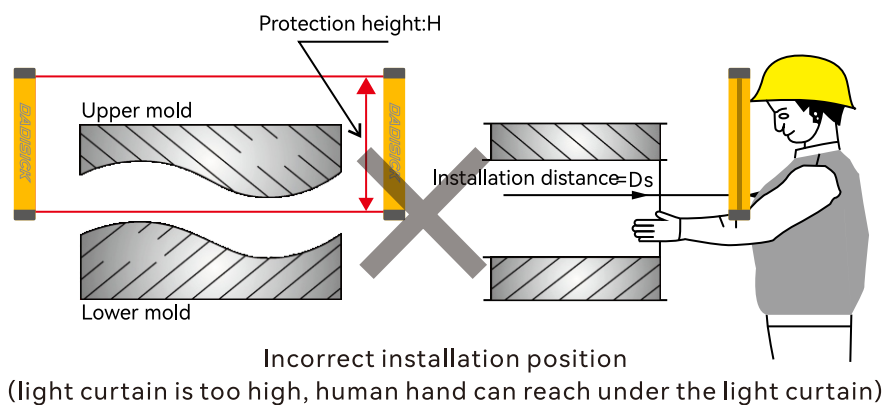
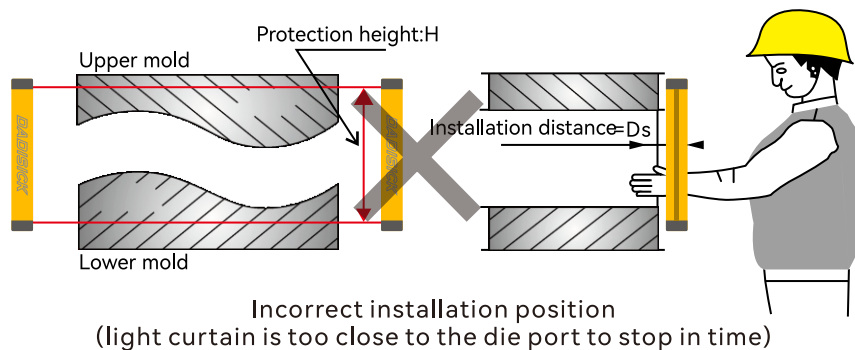
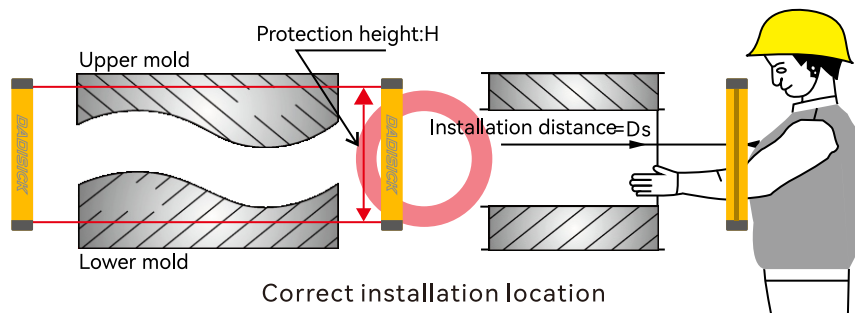

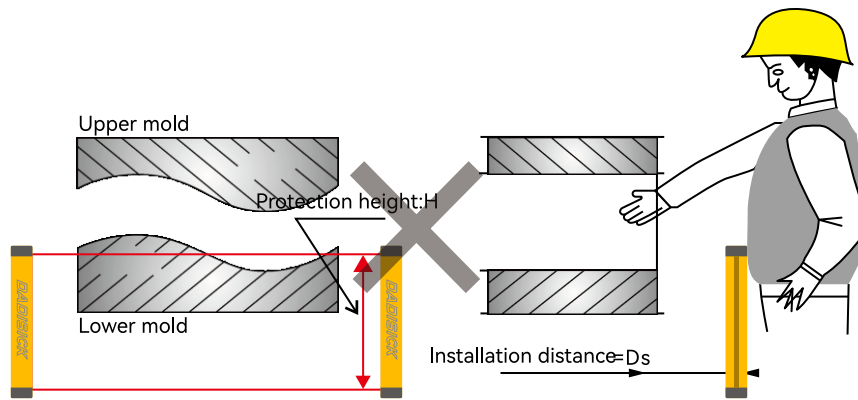

Incorrect installation position
(light curtain is low, human hand can reach out from the top of the light curtain)



WARNING

- A. The height position is one of the necessary conditions to ensure that the photoelectric protection device realizes the protection function, and the height position must be ensured correctly during installation.
- B. If the mold is replaced during use, the safety distance and height position must be readjusted according to the above two requirements.

2. Setting of auxiliary protective measures

When the horizontal distance between the light curtain plane of the photoelectric protection device and the front end of the mold base exceeds 400mm, auxiliary photoelectric or protective fences should be installed to prevent the operator's body from entering the inside of the light curtain plane. When it is less than 400mm, safety measures such as auxiliary photoelectric or protective fence can also be taken.

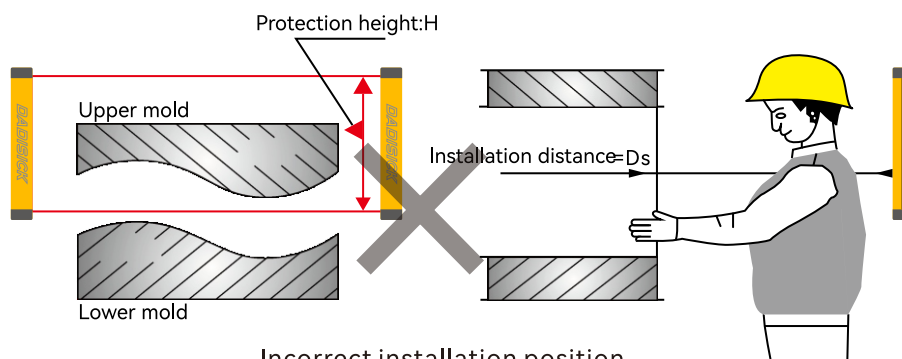

Incorrect installation position
(too far from the die port for people to enter the danger zone)