

USER MANUAL

LASER OBSTACLE SENSOR LD-05H series

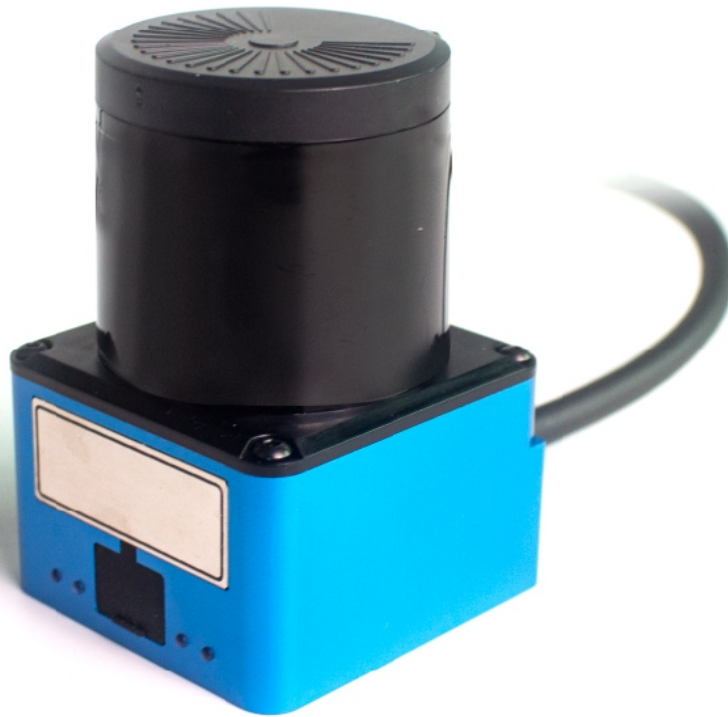

Thank you for using our products.

This manual explains the usage and safety precautions of the product.

*Read this manual carefully and pay attention to safety during use.





*Keep this manual in a suitable place for easy reference.

CONTENTS





| | |
|---|----|
| 1 Safety Precautions | 3 |
| 1.1 Applicable Environment Notes | 3 |
| 1.2 Notes on Wiring Environment | 3 |
| 1.3 Notes on debugging environment | 3 |
| 2 Function Introduction | 4 |
| 2.1 Main Features | 4 |
| 2.2 Functions | 5 |
| 3 Preparation | 7 |
| 3.1 Packing List | 7 |
| 3.2 Debugging Tools | 7 |
| 3.3 Usage steps | 7 |
| 4 Installation | 8 |
| 4.1 Dimensional parameters | 8 |
| 4.2 Detection Capabilities | 9 |
| 4.3 Installation Requirements | 10 |
| 4.4 Ports | 12 |
| 4.5 LED Status Display | 13 |
| 5 Connections | 14 |
| 5.1 Line Definition | 14 |
| 5.2 Power connection | 14 |
| 5.3 Input and output signal connections | 15 |
| 5.3.1 Input signal connection | 15 |
| 5.3.2 Signal combination | 15 |
| 5.3.3 Output Signal Connection | 17 |
| 5.4 Configuration Connection | 18 |
| 5.5 Connection Example | 19 |
| 6 Troubleshooting | 21 |
| 6.1 Fault Status | 21 |
| 6.2 Troubleshooting | 21 |
| 7 After-sales Information | 22 |
| 7.1 Warranty Period | 22 |
| 7.2 Scope of Warranty | 22 |
| 7.3 Scope of Disclaimer | 22 |
| 7.4 Technical Support | 22 |

1 Safety Matters





1.1 Applicable environment notes

-  Visible particles in steam, smoke, dust and air can cause the sensor to misjudge or even fail to work.
-  Regularly arrange for qualified technicians to check whether the sensor is connected and installed correctly.
-  The maximum service life of the sensor is 10 years, after which it must be replaced, otherwise it may not meet the required performance requirements.
-  The sensor should be checked and cleaned regularly.
-  This product is only allowed to be used within the specified limits and the specified technical parameters and operating conditions at any time.

1.2 Notes on wiring environment

-  Do not connect the power supply in reverse or connect it to a voltage higher than the specified maximum working voltage, otherwise the sensor will be damaged.
-  If the power supply is connected to a voltage lower than the specified minimum working voltage, the sensor will not work or work abnormally;
-  Please follow the instructions in the manual for wiring, otherwise the sensor may not be able to detect the input signal correctly;
-  Do not connect the output signal end to a device that exceeds the sensor load capacity, otherwise it will cause the sensor to malfunction.

1.3 Notes on debugging environment

-  Only qualified authorized personnel are allowed to connect, install, debug and set up laser sensors;
-  Confirm that the peripheral equipment associated with the sensor is in a reliable stopped state;
-  Confirm that the debugger himself is in a safe position;
-  Confirm that other people or objects are out of the range of the device.

2 Function Introduction

2.1 Main Features

| Basic characteristics | | |
|--------------------------------|---|---------------|
| Product model | LD-05HN | LD-05HP |
| Working area | 0.05-3m(10%) | 0.05-5m(90%) |
| Product model | LD-10HN | LD-10HP |
| Working area | 0.05-6m(10%) | 0.05-10m(90%) |
| Detection range | 270° | |
| Laser light source | Infrared laser (905nm) | |
| Performance | | |
| Response time | Typical Value 50ms | |
| Basic error | 40mm | |
| Statistical error | 30mm | |
| Number of channels | 64 (each channel contains 3 detection areas) | |
| Detection output delay | Settable within the range of 0ms-500ms | |
| Detection hold delay | Settable within the range of 0ms-500ms | |
| Detection size filtering angle | Settable within the range of 0.5°-5° | |
| Interface | | |
| Configuration port | 1 (Micro-UsB) | |
| Switch input | 6 (PNP) | |
| Switch output | 4 (3 detection signals, 1 fault signal), single-channel load capacity 100mA | |
| Indicator light | 4 (3 detection signal lights, 1 status light) | |
| Electrical performance | | |
| Working voltage | DC18-32V | |
| Current consumption | 60mA typical (without output load) | |
| Working environment | | |
| Object reflectivity | 5%-1000% | |
| Working environment | -10°C-50°C | |
| Ambient light intensity | < 15000lx | |

2.2 Function

LiDAR operates based on the principle of time-of-flight (TOF) measurement. Under a very high synchronous clock, the laser is emitted at uniform time intervals. When the laser beam encounters an object, it is reflected back. After the scanning sensor receives the reflected beam, the distance from the laser sensor to the object is calculated by the time difference Δt between emission and reception.

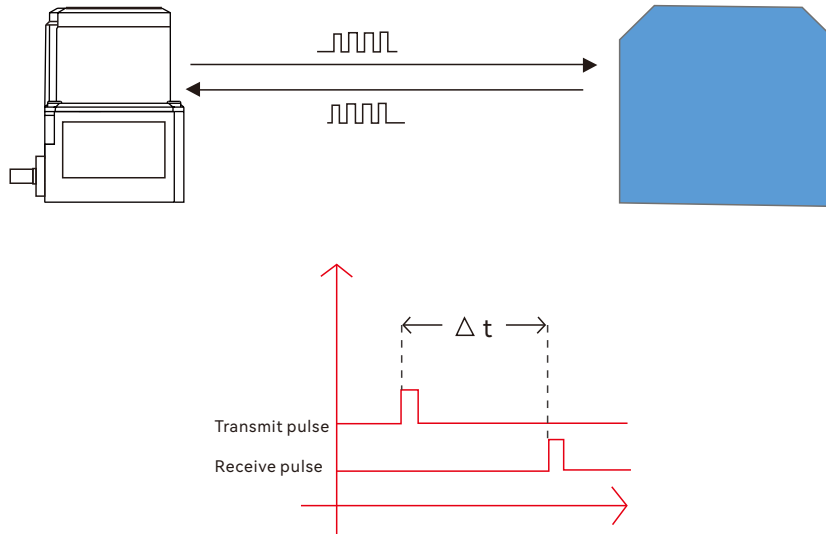

$$\Delta t = \frac{t}{2}$$

$$S = v * \Delta t$$

s : measured distance
 v : laser flight speed
 Δt : time difference
 t : laser flight time (round trip)

The laser beam is used to perform a two-dimensional scan of the surroundings to obtain an environmental contour graphic. The protection area range is established through software configuration. Once an object is in the set area, the sensor will have a corresponding output port signal output. After the upper computer obtains the signal, it will make further judgments and processing.

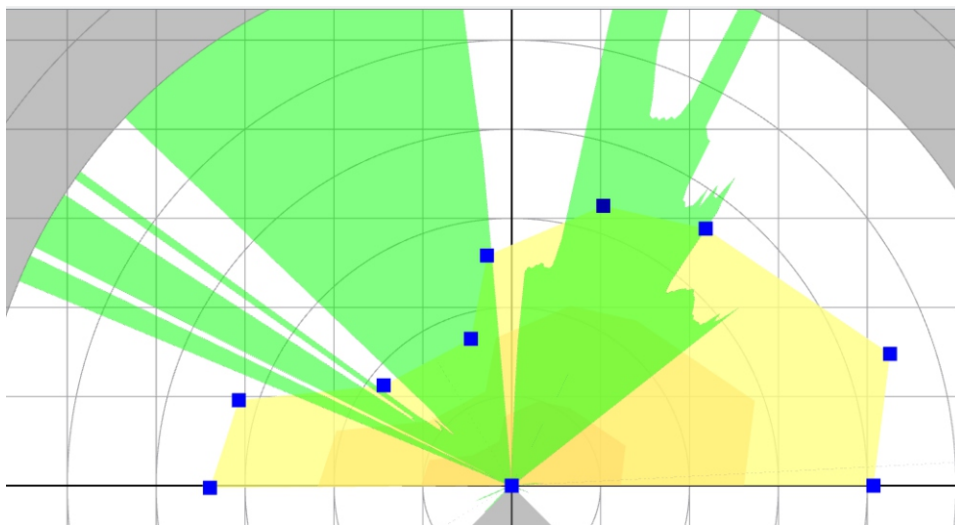

There are 64 channels in the sensor, and up to 64 different sensing ranges can be set. Meet the detection needs in different occasions. The following figure shows the AGV application process.

When the AGV runs to the line A position, the sensing range set by channel 1 is used for detection;

When the AGV runs to the line B position, due to the change of the external space, the original channel 1 sensing range cannot pass, so it switches to channel 2 with a smaller sensing range setting to run through.

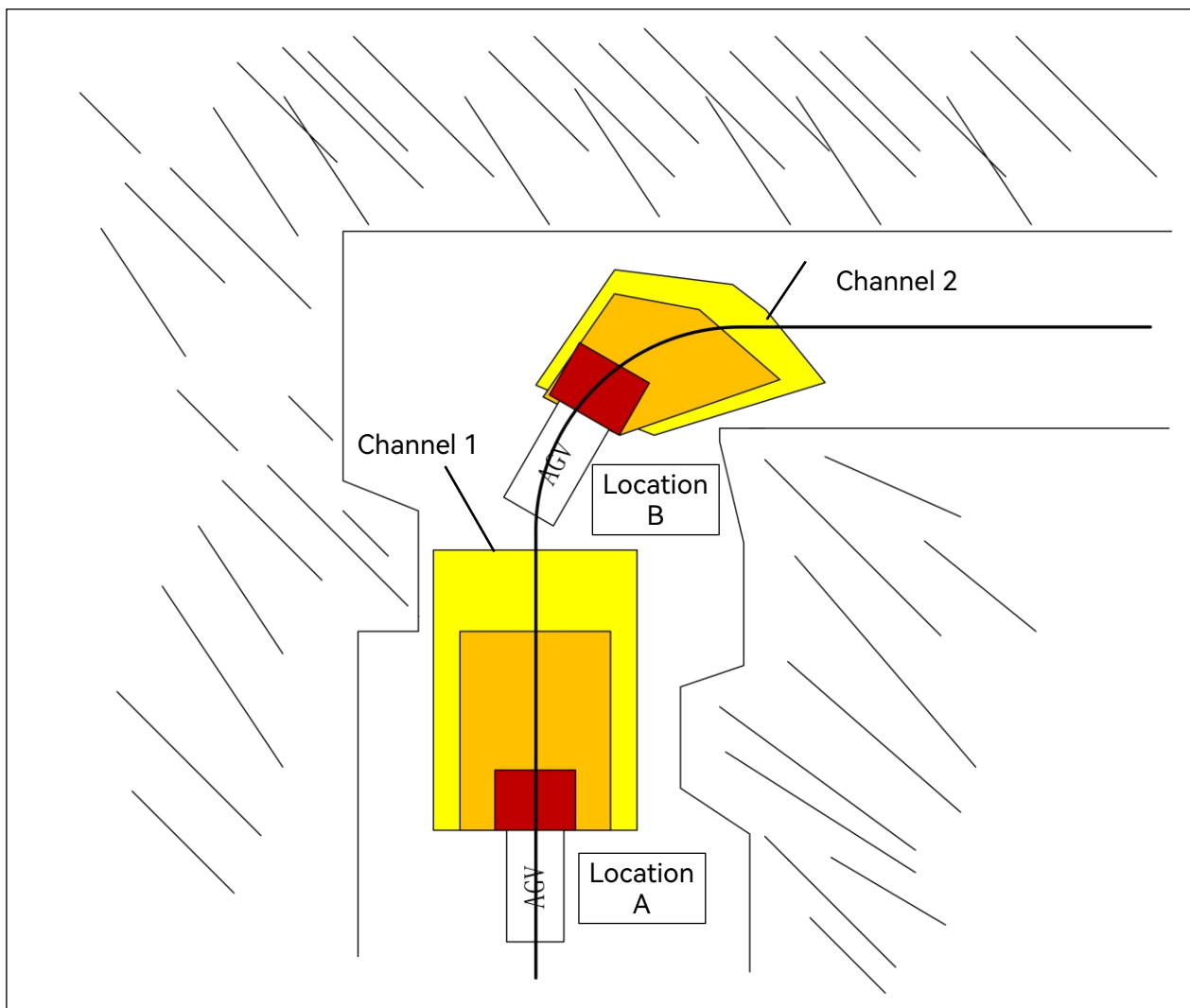

3 Prepare

3.1 Packing List

Please confirm whether the product name and model on the external label of the product packaging box are consistent with what you purchased;

Please confirm the product name and model through the external label of the product;

Please confirm whether the following items are complete after unpacking. If not, please contact the supplier;

| | | |
|------------------------|--------------------------------------|---|
| Laser Obstacle Sensor | LD-05HN | 1 |
| Configuration software | Configuration software V1.3 or above | 1 |

3.2 Debugging Tools

| | | |
|------------|------------------------------|---|
| Connection | USB-Micro USB cable | 1 |
| Computer | Running Windows XP and above | 1 |

3.3 Usage steps

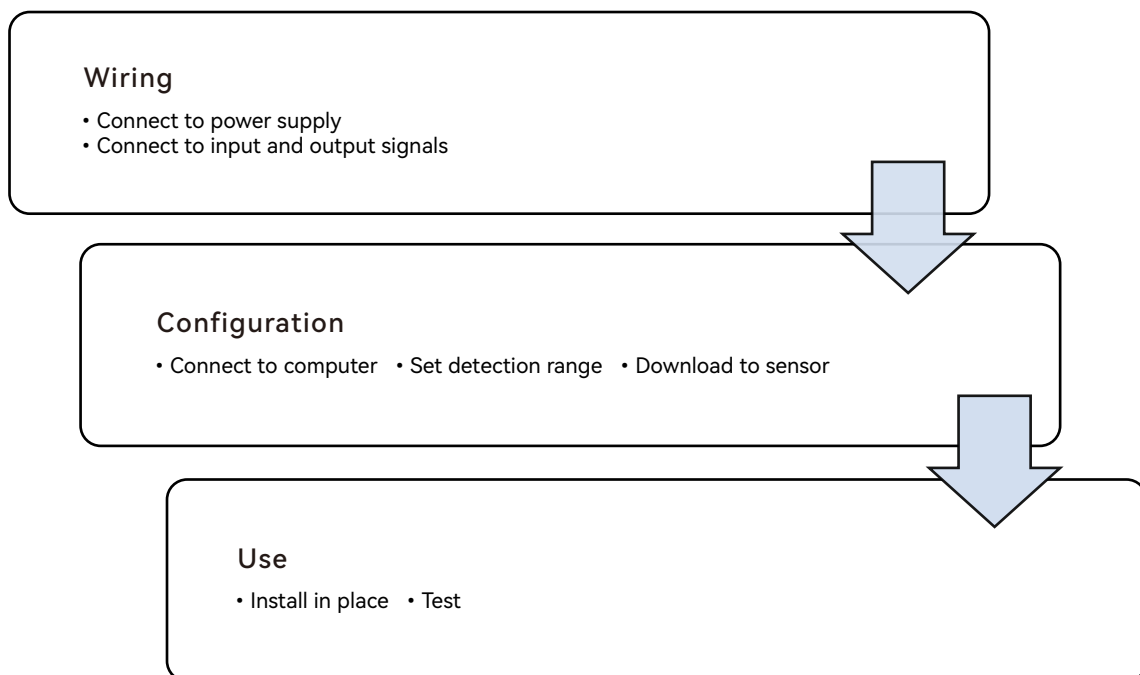

4 Install

4.1 Size parameters

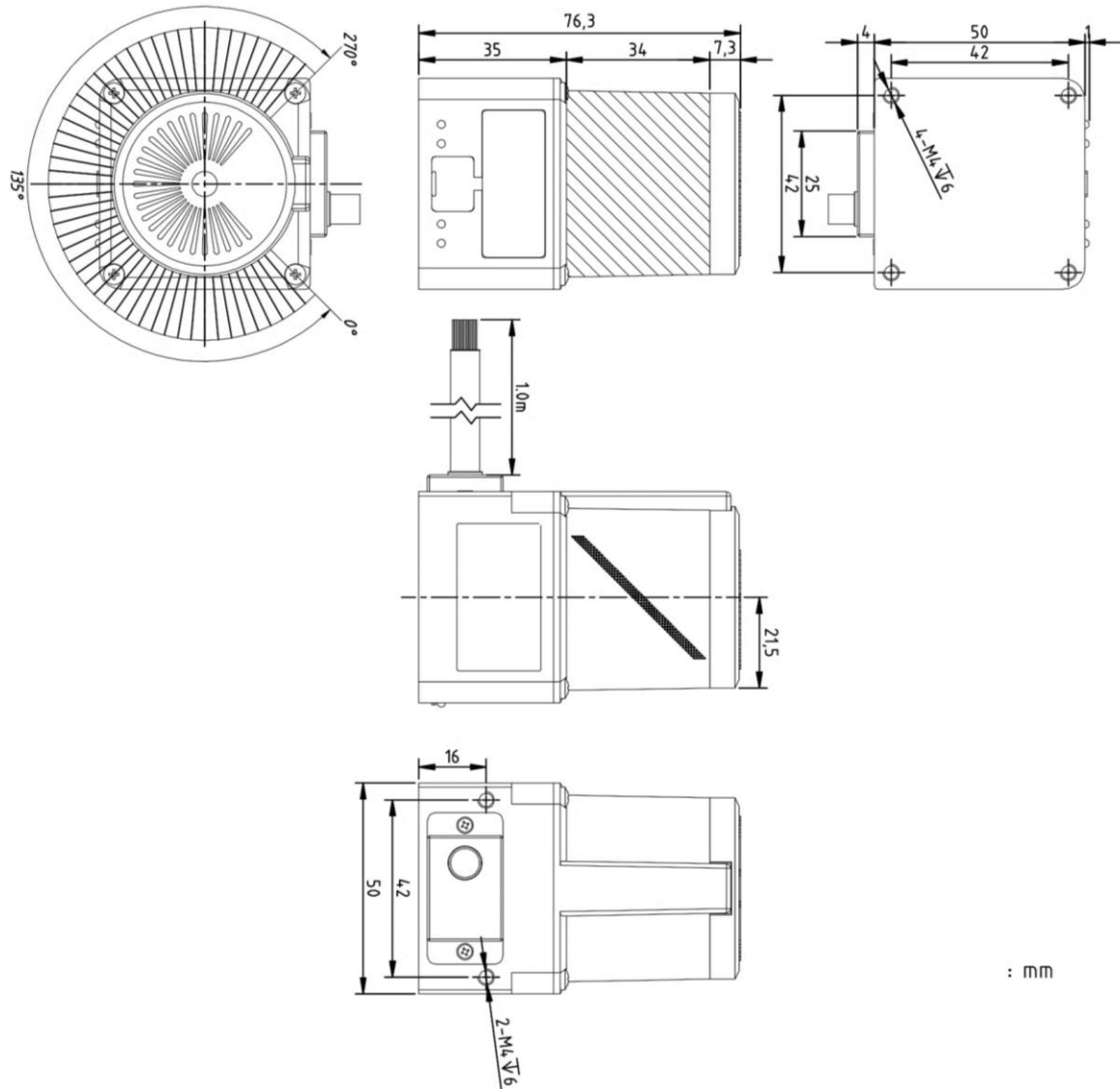

4.2 Detection Capabilities

Detection range

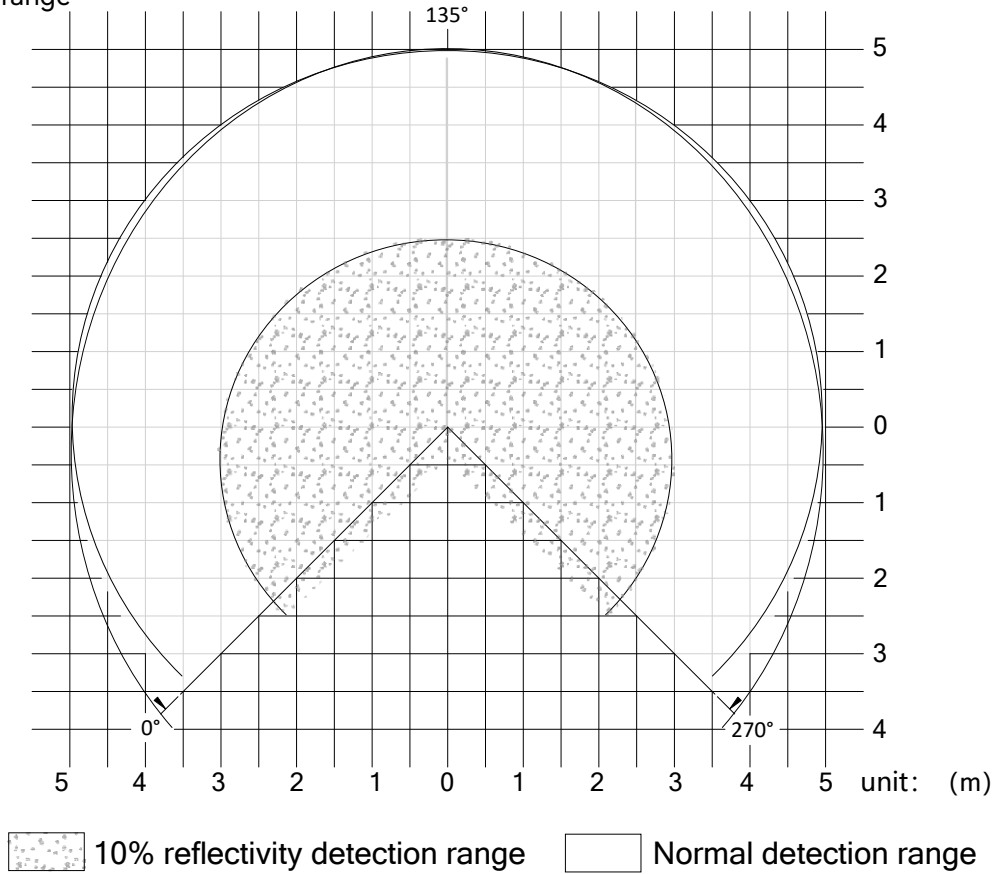

Detecting the size of an object

The laser scanning sensor has a rotating mirror, and the laser beam pulses are continuously emitted at an angle of 0.5 degrees with the rotating mirror, so that a sector-shaped area can be scanned. The emitted laser beam covers a sector surface, so that objects can be identified in an area of up to 270°.

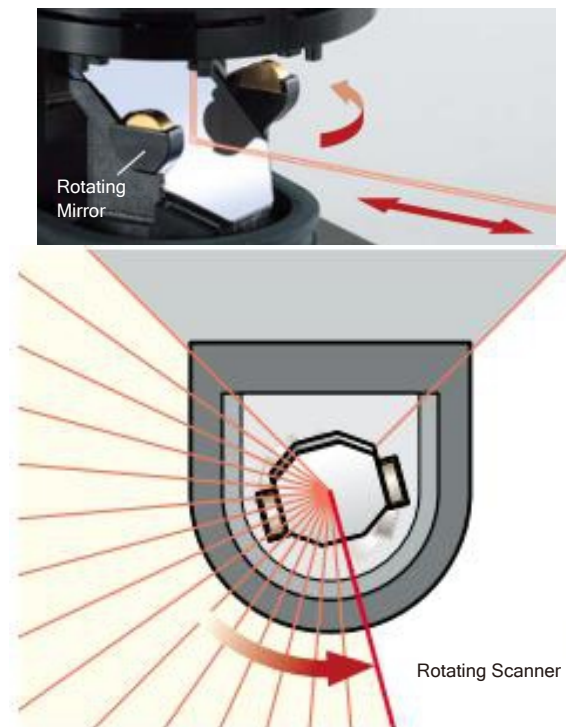

- ① The angular resolution is 0.5 degrees.
- ② The minimum resolution D of the detected object, in mm

Resolution D Calculation Formula

$$\text{Resolution } D = 2\pi L \frac{0.5}{360}$$

L: The distance from any point to the laser sensor, which is also the distance from the measured point to the laser sensor.

For example, when the set length L is 1000mm, the minimum resolution of the object that can be detected is 8.72mm.

Since the laser scanning sensor uses the active scanning principle, no external receiver and reflector are required. This can bring the following advantages:

- ※ Less installation work
- ※ The monitoring area can be easily adjusted to the area of the machine that needs to be protected
- ※ Compared with contact sensors (contact anti-collision), non-contact scanning is almost wear-free

4.3 Installation Requirements

The laser scanning sensor comes with a cable, and a space for the cable outlet needs to be reserved to avoid excessive bending of the cable. The Micro USB jack and indicator light should be reserved in front of the laser scanning sensor base to facilitate connection debugging and observation of the sensor status.

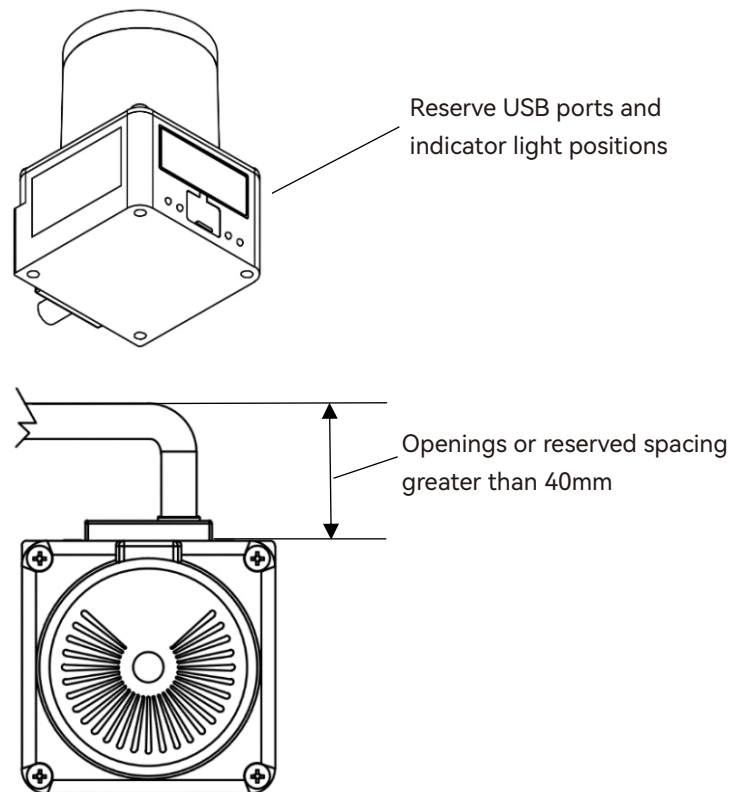

1. When two or more sensors are staggered and installed, it is recommended that the inclination angle be more than 3° to prevent mutual interference.

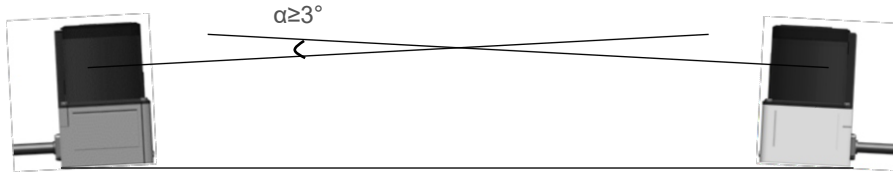

2. When two or more sensors are cross-mounted, it is recommended that the inclination angle be more than 3° to prevent mutual interference.

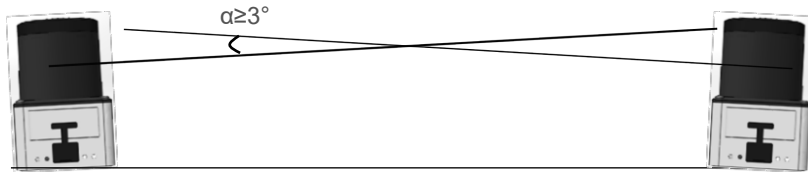

3. When two or more sensors are cross-installed, it is recommended to stagger them by more than 40mm to prevent mutual interference.

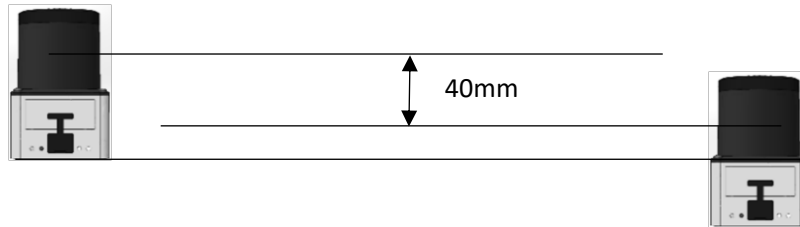

Since the sensor spot emits in a conical divergent shape, it is recommended that the laser scanning sensor be installed at a height of $\geq 200\text{mm}$ from the ground. If the installation height is $< 200\text{mm}$ from the ground, please tilt the laser scanning sensor upward by $1\sim 3^\circ$.

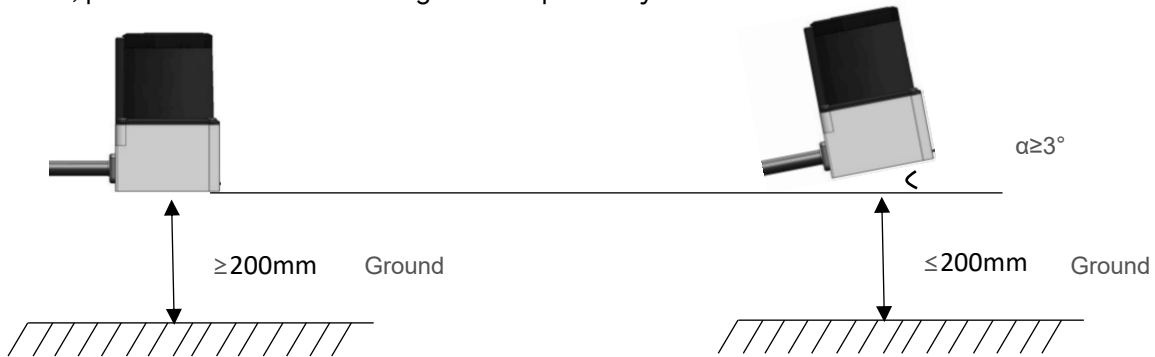

Front installation diagram

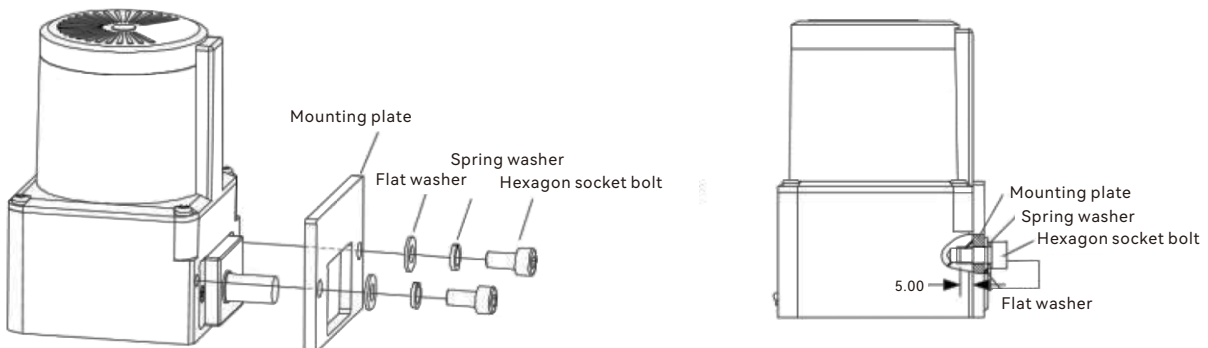

Bottom installation diagram

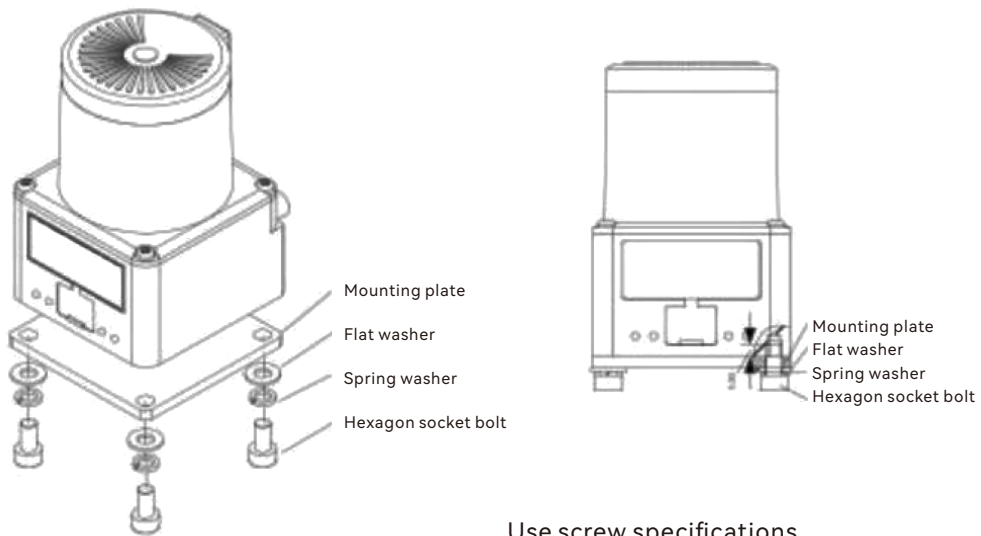

Use screw specifications

| Screw specifications | Tightening torque |
|----------------------|-------------------|
| M4*10mm | 0.1N.M |

4.4 Port

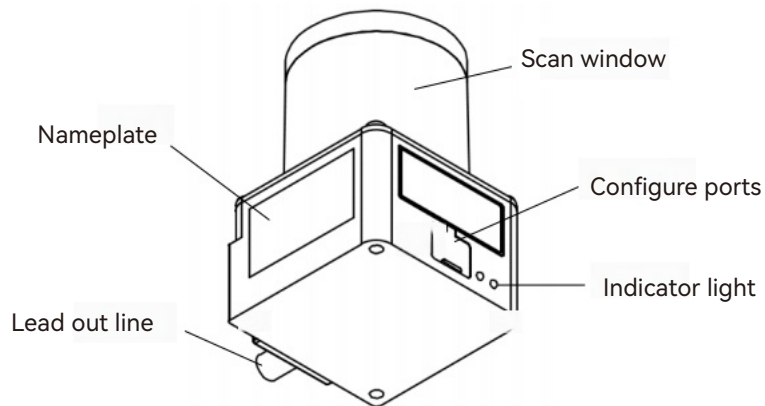

4.5 LED Status Display

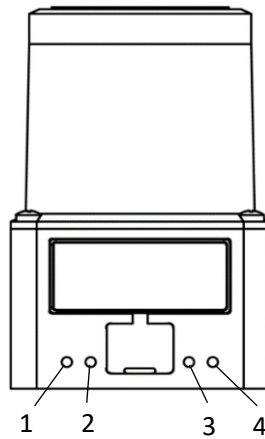

| NO | Name | Functional Description |
|----|-----------------|---|
| 1 | Power indicator | When the laser sensor receives the correct power supply, it lights up as a green indicator light. When an internal fault occurs, the power indicator light flashes |
| 2 | OUT3 indicator | If intrusion is detected within the setting range of laser sensor OUT3, the red indicator light will light up. If intrusion is not detected, it will not light up. |
| 3 | OUT2 indicator | If intrusion is detected within the setting range of laser sensor OUT2, the yellow indicator light will light up. If intrusion is not detected, it will not light up. |
| 4 | OUT1 indicator | If intrusion is detected within the setting range of laser sensor OUT1, the orange indicator light will light up. If intrusion is not detected, it will not light up. |

5 Connection

5.1 Line Definition

The sensor cable leads to 14 core wires, and the wire color definition corresponds to the following table

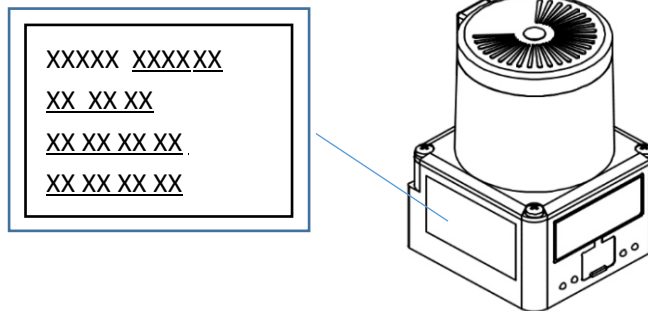

| Colors | Model Type | Signal | Function Description |
|-------------|-----------------|-----------|---|
| Brown | Power supply | DC 24V | Positive pole of power supply 18-32V |
| Blue | Power supply | 0V | Negative pole of power supply |
| White Brown | Common terminal | INCOM | Input common terminal |
| Black | Input | IN1 | Input port 1 |
| Orange | | IN2 | Input port 2 |
| Yellow | | IN3 | Input port 3 |
| Green | | IN4 | Input port 4 |
| Purple | | IN5 | Input port 5 |
| Gray | | IN6 | Input port 6 |
| White | Common terminal | OUTCOM | Output common terminal |
| White Green | Output | OUT1 | Warning: Zone 2 has sensed an object and the port has acted |
| White Blue | | OUT2 | Warning: Zone 1 has sensed an object and the port has activated |
| Red | | OUT3 | The port will act when the protected area senses an object |
| White Red | | ERROR OUT | Port action when sensor fails |

5.2 Power Connection

Power supply: DC24V \pm 10%; In the AGV system or other power equipment networks, it is necessary to add a DC24V voltage regulator to ensure that power interference does not affect the normal operation of sensors.

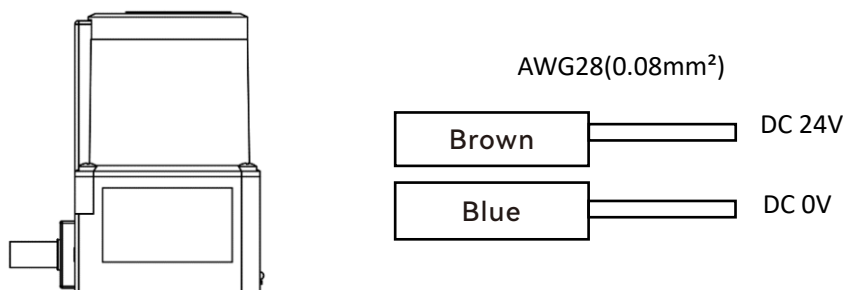

5.3 Input and output signal connection

5.3.1 The input signal

Connection input is an open collector (NPN/PNP) signal, using optocoupler isolation input. Use external power supply: (NPN COM+) / (PNP COM-) input DC24V±20%, 100mA or more;

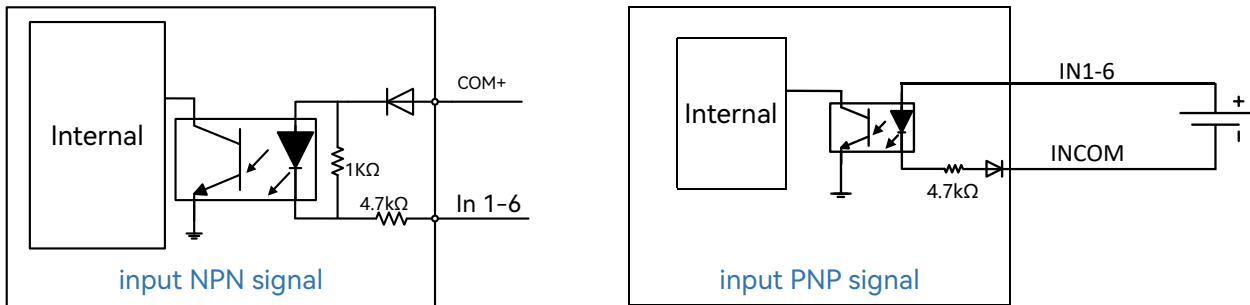

The sensor has 64 channels, and the input signal combination is switched to the specified channel number through 6 IO ports. The detection range of the channel needs to be set in advance through the configuration software. The external device selects and switches the area through the input signal.

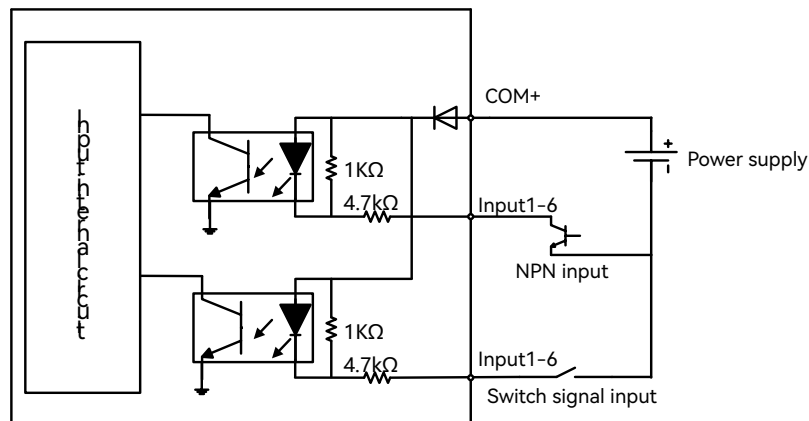

5.3.2 Signal combination

LD-5H sensor provides 6 input port combination signals.

ON: input has signal;

OFF: input has no signal or is open circuit;

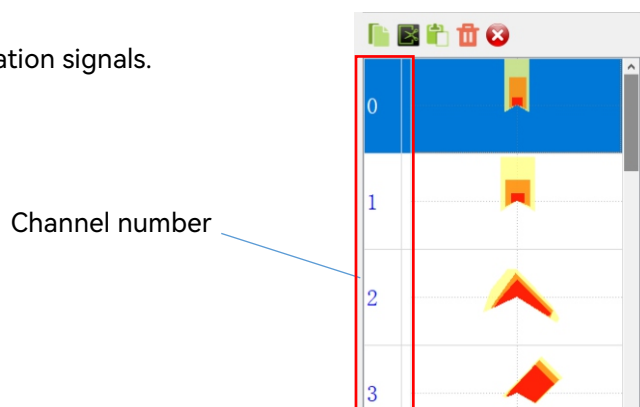

| Channel number | In6 | In5 | In4 | In3 | In2 | In1 |
|----------------|-----|-----|-----|-----|-----|-----|
| 63 | OFF | OFF | OFF | OFF | OFF | OFF |
| 62 | OFF | OFF | OFF | OFF | OFF | ON |
| 61 | OFF | OFF | OFF | OFF | ON | OFF |

| Channel number | In6 | In5 | In4 | In3 | In2 | In1 |
|----------------|-----|-----|-----|-----|-----|-----|
| 60 | OFF | OFF | OFF | OFF | ON | ON |
| 59 | OFF | OFF | OFF | ON | OFF | OFF |
| 58 | OFF | OFF | OFF | ON | OFF | ON |
| 57 | OFF | OFF | OFF | ON | ON | OFF |
| 56 | OFF | OFF | OFF | ON | ON | ON |
| 55 | OFF | OFF | ON | OFF | OFF | OFF |
| 54 | OFF | OFF | ON | OFF | OFF | ON |
| 53 | OFF | OFF | ON | OFF | ON | OFF |
| 52 | OFF | OFF | ON | OFF | ON | ON |
| 51 | OFF | OFF | ON | ON | OFF | OFF |
| 50 | OFF | OFF | ON | ON | OFF | ON |
| 49 | OFF | OFF | ON | ON | ON | OFF |
| 48 | OFF | OFF | ON | ON | ON | ON |
| 47 | OFF | ON | OFF | OFF | OFF | OFF |
| 46 | OFF | ON | OFF | OFF | OFF | ON |
| 45 | OFF | ON | OFF | OFF | ON | OFF |
| 44 | OFF | ON | OFF | OFF | ON | ON |
| 43 | OFF | ON | OFF | OFF | ON | OFF |
| 42 | OFF | ON | OFF | ON | OFF | ON |
| 41 | OFF | ON | OFF | ON | ON | OFF |
| 40 | OFF | ON | OFF | ON | ON | ON |
| 39 | OFF | ON | ON | OFF | OFF | OFF |
| 38 | OFF | ON | ON | OFF | ON | ON |
| 37 | OFF | ON | ON | OFF | ON | OFF |
| 36 | OFF | ON | ON | OFF | ON | ON |
| 35 | OFF | ON | ON | ON | OFF | OFF |
| 34 | OFF | ON | ON | ON | OFF | ON |
| 33 | OFF | ON | ON | ON | ON | OFF |
| 32 | OFF | ON | ON | ON | ON | ON |
| 31 | ON | OFF | OFF | OFF | OFF | OFF |
| 30 | ON | OFF | OFF | OFF | OFF | ON |
| 29 | ON | OFF | OFF | OFF | ON | OFF |
| 28 | ON | OFF | OFF | OFF | ON | ON |
| 27 | ON | OFF | OFF | ON | OFF | OFF |
| 26 | ON | OFF | OFF | ON | OFF | ON |
| 25 | ON | OFF | OFF | ON | ON | OFF |
| 24 | ON | OFF | OFF | ON | ON | ON |
| 23 | ON | OFF | ON | OFF | OFF | OFF |
| 22 | ON | OFF | ON | OFF | OFF | ON |
| 21 | ON | OFF | ON | OFF | ON | OFF |
| 20 | ON | OFF | ON | OFF | ON | ON |

| Channel number | In6 | In5 | In4 | In3 | In2 | In1 |
|----------------|-----|-----|-----|-----|-----|-----|
| 19 | ON | OFF | ON | ON | OFF | OFF |
| 18 | ON | OFF | ON | ON | OFF | ON |
| 17 | ON | OFF | ON | ON | ON | OFF |
| 16 | ON | OFF | ON | ON | ON | ON |
| 15 | ON | ON | OFF | OFF | OFF | OFF |
| 14 | ON | ON | OFF | OFF | OFF | ON |
| 13 | ON | ON | OFF | OFF | ON | OFF |
| 12 | ON | ON | OFF | OFF | ON | ON |
| 11 | ON | ON | OFF | ON | OFF | OFF |
| 10 | ON | ON | OFF | ON | OFF | ON |
| 9 | ON | ON | OFF | ON | ON | OFF |
| 8 | ON | ON | OFF | ON | ON | ON |
| 7 | ON | ON | ON | OFF | OFF | OFF |
| 6 | ON | ON | ON | OFF | OFF | ON |
| 5 | ON | ON | ON | OFF | ON | OFF |
| 4 | ON | ON | ON | OFF | ON | ON |
| 3 | ON | ON | ON | ON | OFF | OFF |
| 2 | ON | ON | ON | ON | OFF | ON |
| 1 | ON | ON | ON | ON | ON | OFF |
| 0 | ON | ON | ON | ON | ON | ON |

Reminder: If you do not need to use all 64 channels, you can determine the input signal to be connected based on the number of channels required;

Switching time

After the sensor receives the channel switching signal, there is a switching delay due to the influence of the scanning cycle. The switching delay is shown in the figure below.

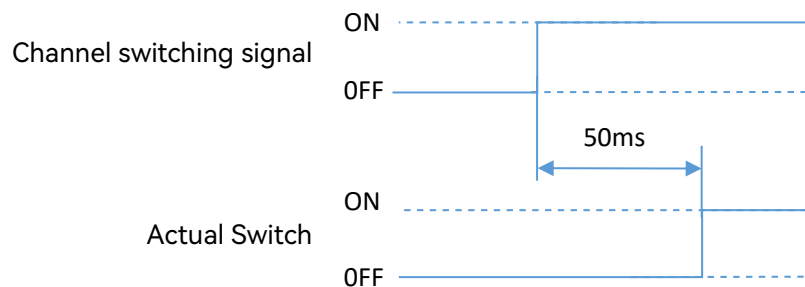

Note: When switching to a non-graphic channel, the sensor will maintain the previous status monitoring of the graphics channel;

5.3.3 Output signal connection

Output signal usage function

OUT1: used for remote obstacle warning and deceleration;

OUT2: used for normal obstacle detection and normal stop;
 OUT3: used for near-end emergency stop;

The output is an open collector (NPN) signal, using optocoupler isolation output. When there is a signal, the voltage is 0V-, and the maximum load capacity of the output port is 100mA.

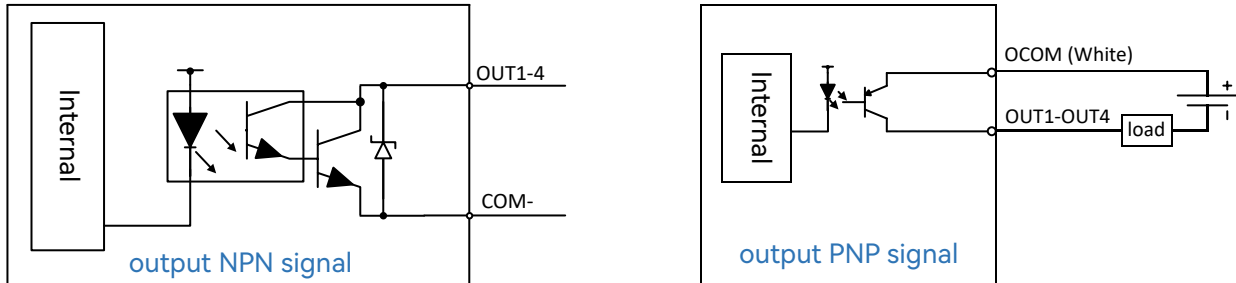

The output ports are all NPN outputs. Please refer to the following figure for the output schematic:

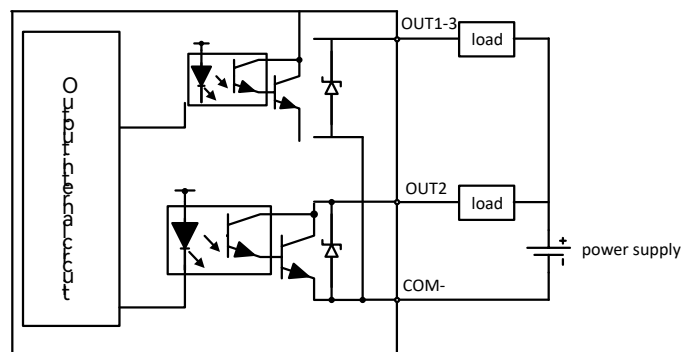

The sensor output ports correspond to the graphics drawn in the configuration software.

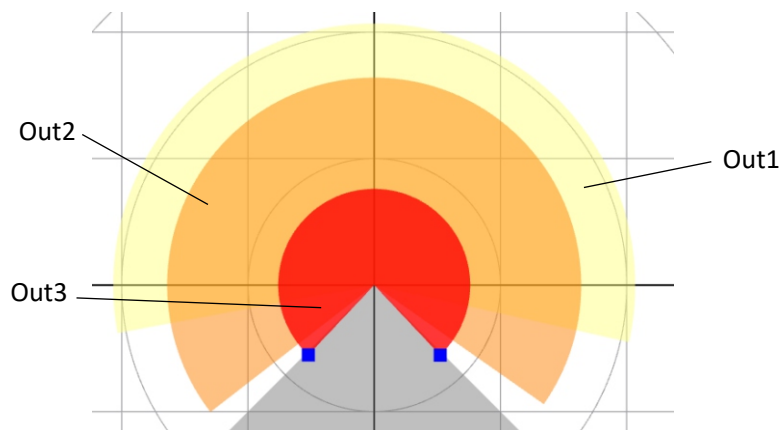

Note: There will be detection output only when there is a drawing graph for the corresponding output;

5.4 Configuring Connections

Use the Micro-USB port cable to connect the computer to the sensor

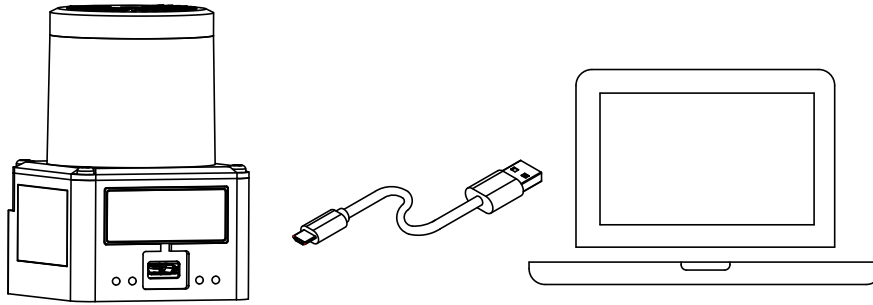

Notice | Connecting the data cable to the sensor end in the wrong direction will damage the sensor port. You must use a cable that can transmit data. The charging cable cannot be connected successfully.

NPN Wiring Diagram

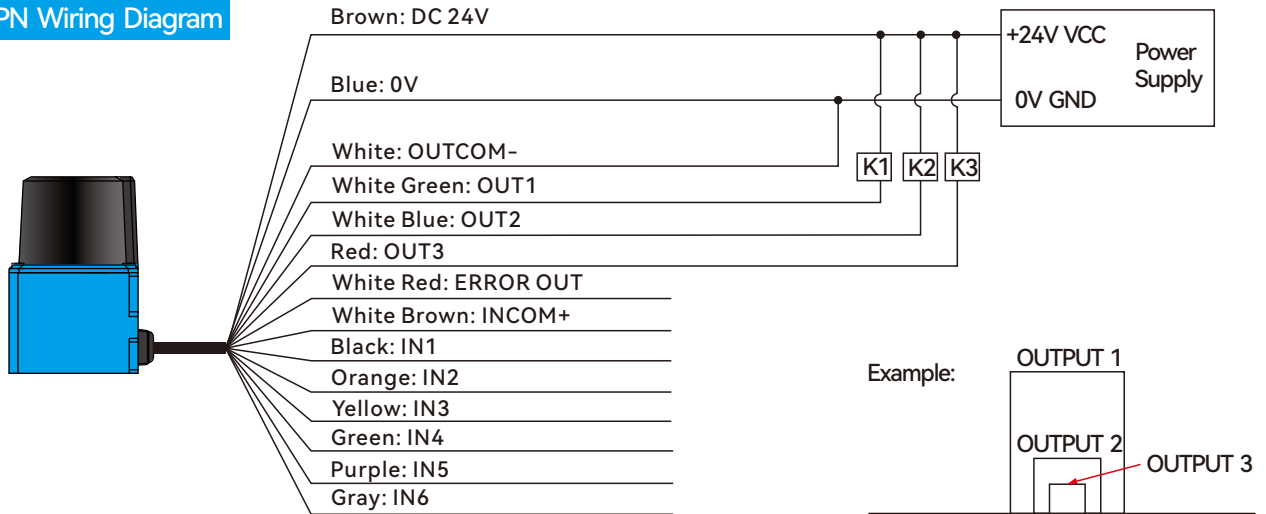

PNP Wiring Diagram

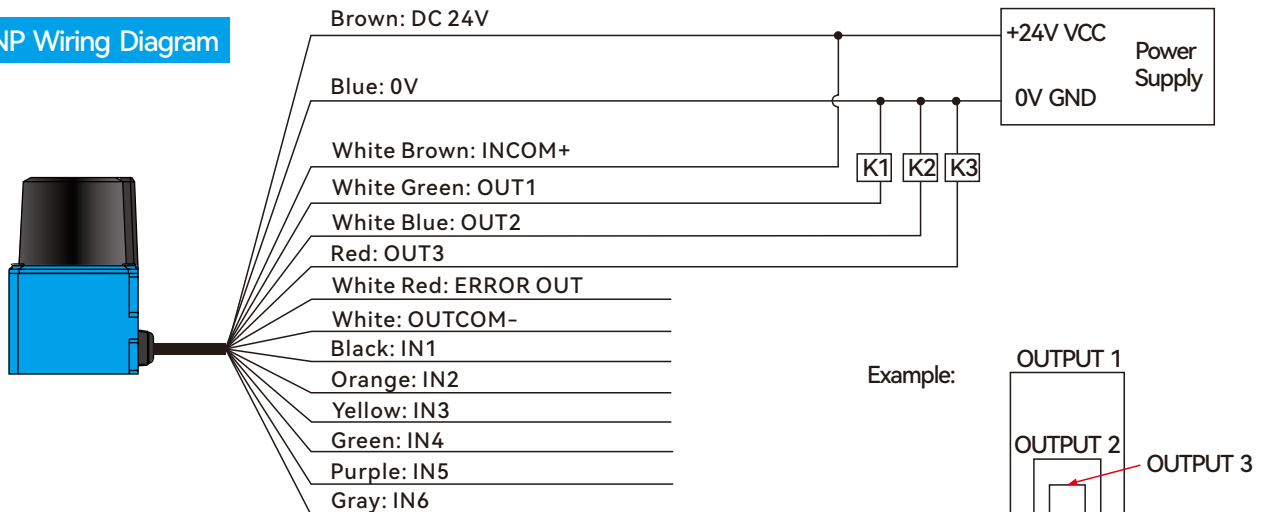

5.5 Connection Example

Based on the wiring when all 64 channels are used and all outputs are used.

NPN signal wiring

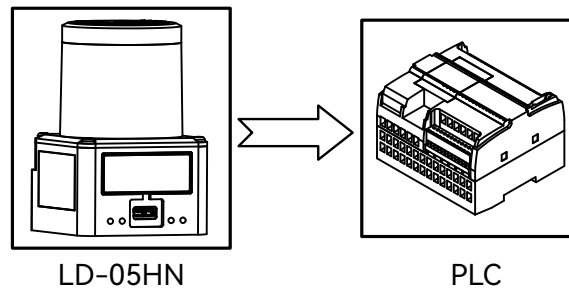

The figure below shows that the host computer outputs and receives signals through NPN transistors.

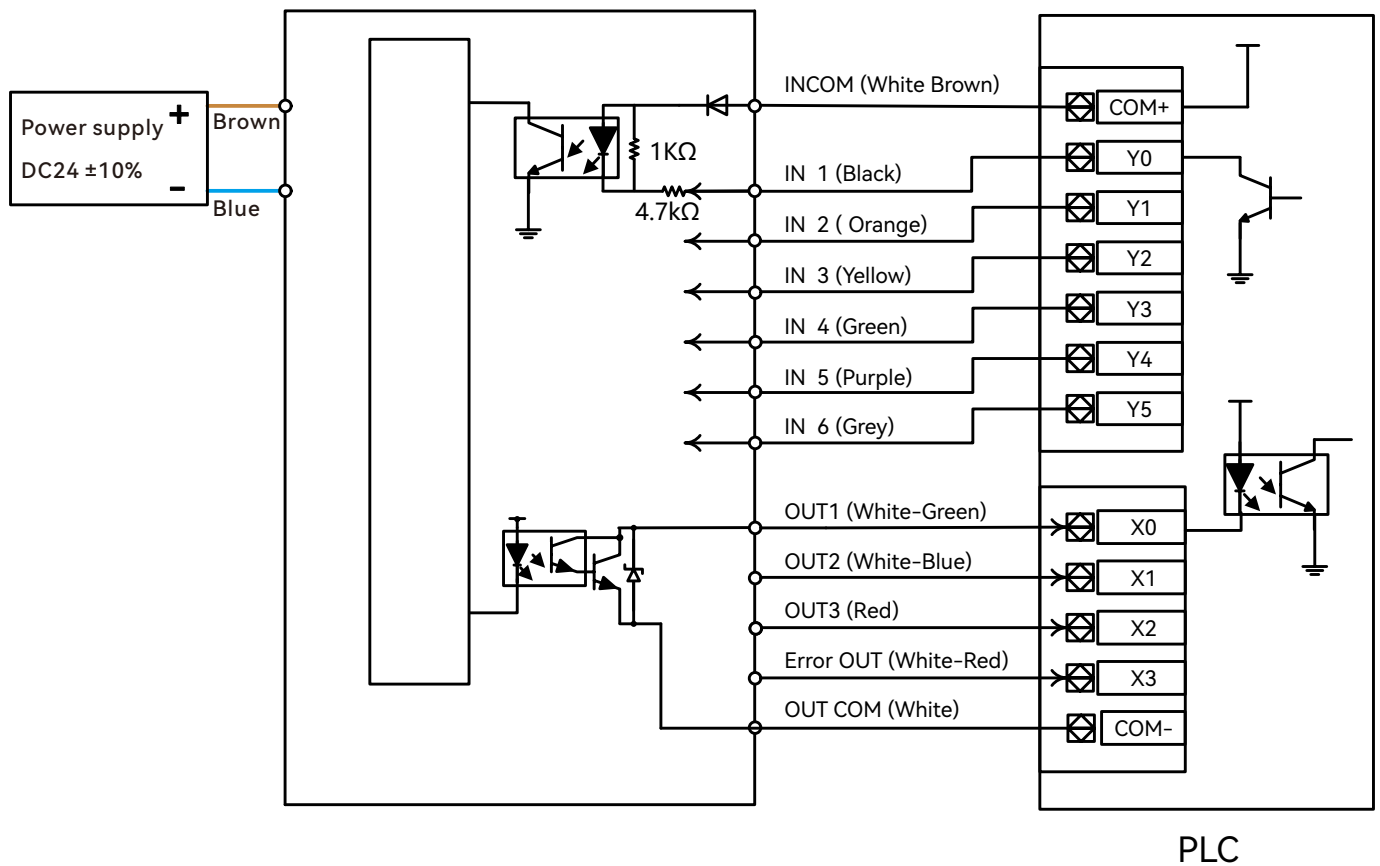

X0-3 is the signal input port of PLC;
 Y0-Y5 are the signal output ports of PLC;
 IN1-IN6 input current is greater than 10mA;
 Out1-Out4 output current is less than 100mA;

Note: The input and output ports cannot be short-circuited or connected to a load exceeding the specified current, otherwise the sensor will be damaged.

PNP signal wiring

Also available as PNP output model: LD-05HP

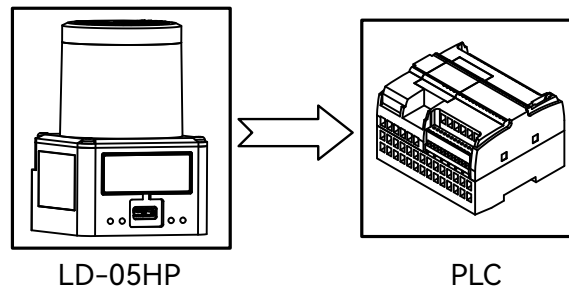

The figure below shows that the host computer outputs and receives signals through NPN transistors.

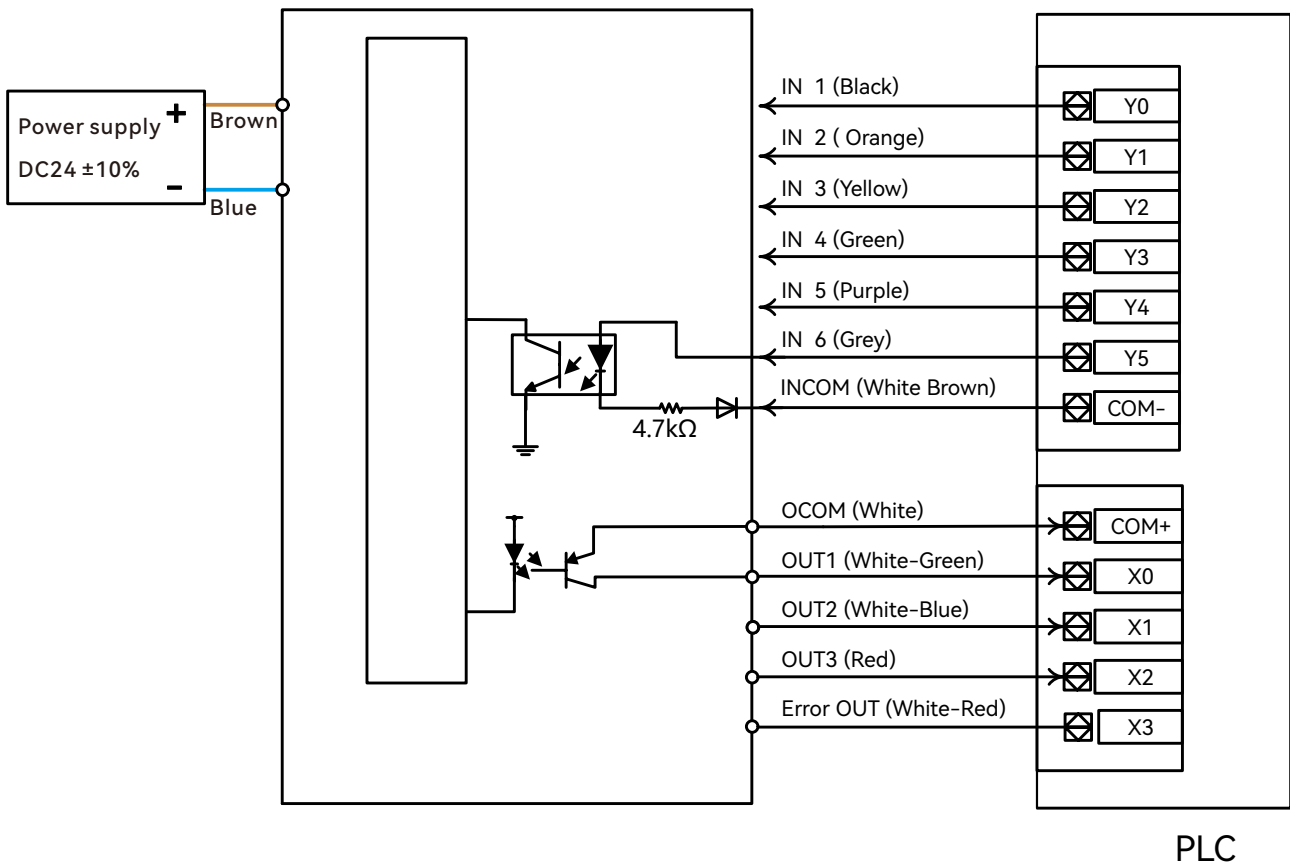

X0-3 is the signal input port of PLC;
 Y0-Y5 are the signal output ports of PLC;
 IN1-IN6 input current is greater than 10mA;
 Out1-Out4 output current is less than 100mA;

Note: The input and output ports cannot be short-circuited or connected to a load exceeding the specified current, otherwise the sensor will be damaged.

6 Troubleshooting

6.1 Fault Status

The sensor indicates a fault through the green LED light of the sensor power status. When the green LED flashes, the sensor will stop outputting signals.

| | |
|------------------|----------------|
| LED flashes | Sensor failure |
| LED is always ON | Normal state |

6.2 Troubleshooting

When a sensor fails to work properly or the sensor status cannot be determined, follow the process below to troubleshoot and confirm the problem.

| Fault | Solve |
|----------------------------|---|
| Unable to detect objects | Use the configuration software to view and monitor the current channel status and drawn detection areas. |
| Channel cannot be switched | Check whether the IN1-IN6 signal input is correct; |
| Output signal flashes | 1) When the sensing range is at a critical point, the output port may become unstable. If necessary, you should consider expanding the protection area. 2) There is dust on the sensor window; |

7 After-sales information

7.1 Warranty Period

LD-05HN provides a limited warranty. During the warranty period, if the product cannot be used normally due to quality problems, design defects, etc., we will provide free after-sales maintenance.

- Warranty period: 2 years from the date of sale.

7.2 Scope of Warranty

If the product is within the warranty period and falls within the warranty conditions, we will repair or replace it free of charge

- The warranty and after-sales service of this product are limited to mainland China;
- The product cannot be used normally due to unpacking during transportation;
- The product cannot work normally due to damage to the components of the product itself;
- The product cannot be used normally due to design defects;

7.3 Scope of Disclaimer

Please pay attention to the following conditions during the use of the product. We will not provide free after-sales and warranty.

- Failure to install the product correctly according to the instructions, resulting in product damage;
- Use the product in an unsuitable environment and conditions, resulting in product damage;
- Product damage caused by failure to operate in accordance with the product manual;
- Unauthorized disassembly or repair of the product without the company's permission;
- Product damage caused by irresistible external forces such as natural disasters and fires.

7.4 Technical Support

Dongguan Dadi Electronic Technology Co., Ltd.
<https://www.dadisick.com>