

USER'S MANUAL

Simple Color Recognition Sensor GS-101 Series

Product characteristics

- The dual-mode mode has both color and light intensity detection functions;
- Intelligent detection of various colors, automatic identification;
- The signal is output only when the required color is detected.



- Thank you for your purchase.
- Please read this manual carefully before use and keep it in a safe place for easy access.

Product Suitability Statement

Dadi Technology's products are designed and manufactured for general use in general industries. Therefore, our products must not be used in the following applications and are not suitable for their use. However, if the purchaser consults us in advance about the use of the product with a responsible attitude and understands the technical specifications, grades and performance of the product, and takes necessary safety measures, the product can be used. In this case, the product warranty is the same as above.

- Facilities that have a serious impact on life and property, such as nuclear power plants, airports, railways, ships, motor vehicles and medical equipment;
- Public utilities such as electricity, gas and water supply services;
- Outdoor use in similar conditions or environments.

Application Scenarios

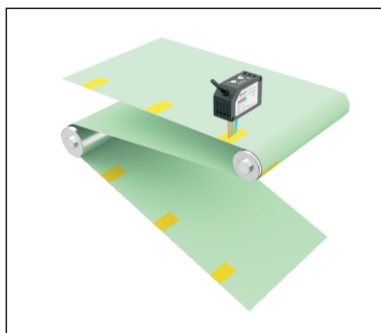

Check alignment marks

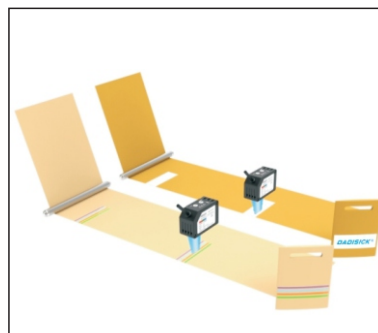

Detect folder labels

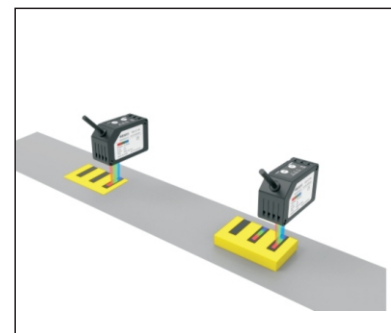

Detect the color block of the conveyor belt target

Product Parameters

Type	NPN		PNP	
Model	GS-101N		GS-101P	
Detection distance	18 to 28mm			
Power supply voltage	24V DC ± 10% pulsation P-P below 10%			
Electricity consumption	The power is below 850mW (when the power supply voltage is 24V, the consumed current is below 35mA)			
Mode switching input	Color pattern	Low (ON) 0 to 0.6V DC Outflow current below 0.5mA The input impedance is about 10KΩ		Low (OFF) 0 to 0.6V DC or open
	Color mode	High (OFF) 12 to +24V DC or open		High (on) 12 to + 24V DC Outflow current below 3mA The input impedance is about 10kΩ
Output	NPN open collector transistor · Maximum inflow current 50mA · Applied voltage below 30V DC (between output and 0V) · Residual voltage below 1.5 V (when inflow current is 50mA) *		PNP open collector transistor · Maximum outflow current 50mA · Applied voltage below 30V DC (between output and + V) · Residual voltage below 1.5 V (when outflow current is 50mA) *	
Output operation	Color pattern	ON when color code is detected		
	Color mode	Consistent ON		
Short circuit protection	Equipped (automatic recovery)			
Reaction time	Below 200μs			
Ambient temperature	-10 to + 55 °C, no freezing, no condensation			
Ambient humidity	35 to 85% RH, no coagulation			
Light projecting element	Composite LED: Red/Green/Blue (Projection peak wavelength: 640nm/525nm/470nm)			
Material	Shell: PBT/Operation Panel: PC/Operation Button: Silicone/Lens: PC			
Cable	0.2mm ² 4-core rubber cable, standard length 2m Brown: + V/Black: Output/Pink: Mode Transition Input/Blue:0V			
Weight	Approximately 104g			

* Specified measurement conditions: ambient service temperature + 23 °C.

Indicator Light Description

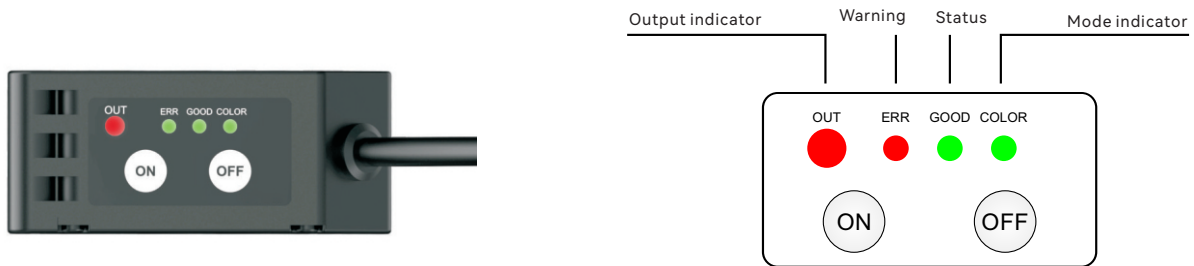

Dimension specification

GS-101

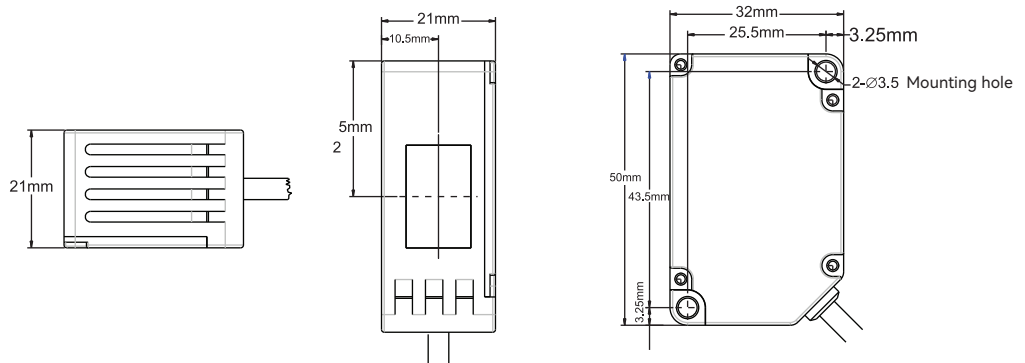

Input/output wiring diagram

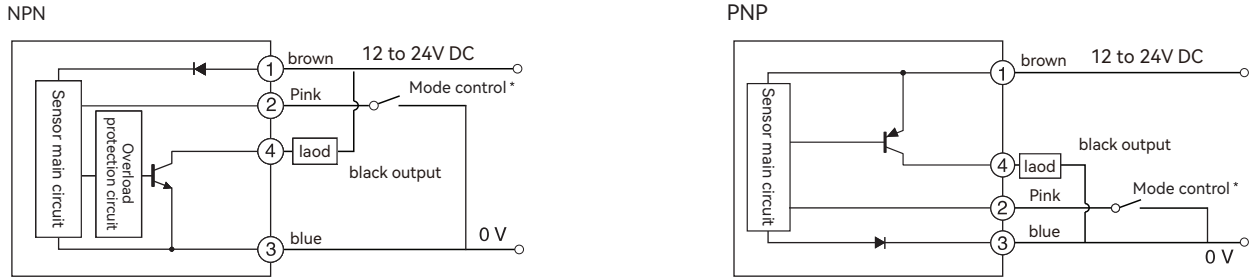

Note: the color mode is when the pink line is off, and the color code mode is when the pink line is on

Two detection modes

Color Mode

When the color to be detected is detected, the signal will be output.



The sensor emits RGB three-color light

The color mode and color mark mode are just different in the light source they emit; when the default color mode cannot detect the problem, you can switch to the color mark mode.

Color scale mode

The sensor emits a monochromatic light source.



Detection between two colors, even when the color difference is very small.

Note: To switch the color code mode, do the following: If it is NPN output, connect the pink line to 0V, if it is PNP output, connect the pink line to 24V.

Attention! The following objects cannot be detected



Screen Color



Liquid Color



Light Color

Installation Instructions

Please pay attention to the installation direction of the sensor for the moving direction of the detected object. The tightening torque should be below 0.8N·m.

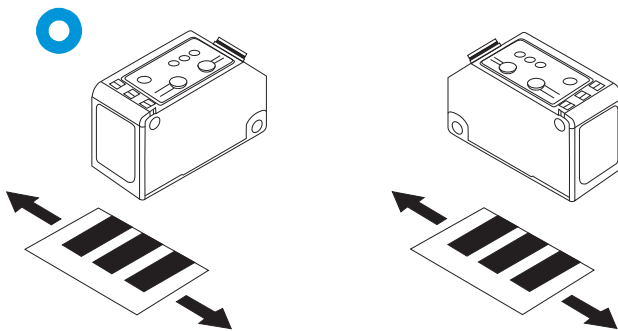

Be careful not to use the sensor to detect objects in this direction, as this may cause unstable operation.

How to use

Press twice, the setting is complete and you can use it.

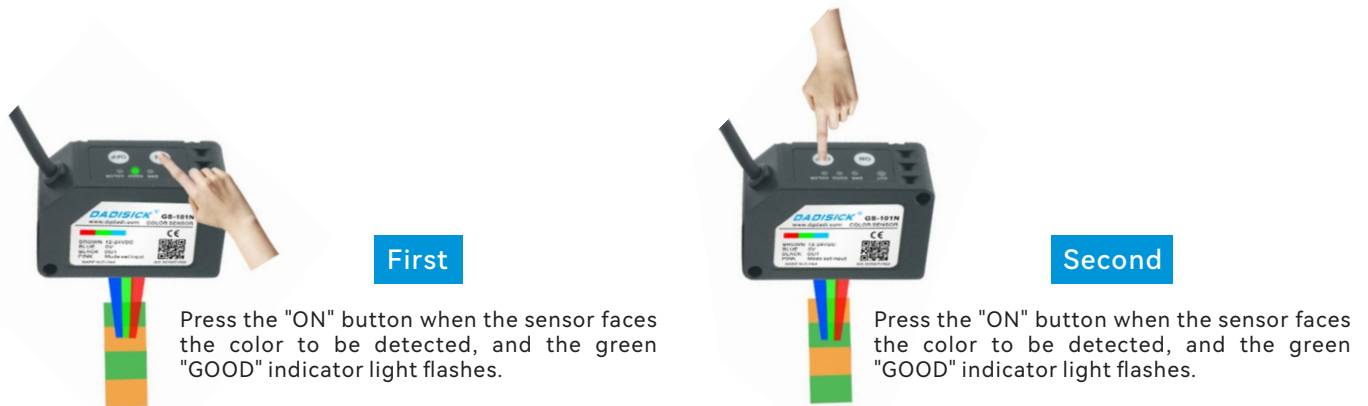

Press the "ON" button when the sensor faces the color to be detected, and the green "GOOD" indicator light flashes.

Press the "ON" button when the sensor faces the color to be detected, and the green "GOOD" indicator light flashes.

1. In the setting step 1-2, if the "GOOD" indicator light can remain on for a long time, it means that the detection can be started normally.
2. In the setting step 1-2, if the "ERR" indicator light flashes, it means that the detection cannot be performed.
3. When the detection setting is unstable, you can adjust it by the following methods:
 - 1>> Switch mode
 - 2>> Adjust the detection hysteresis value (these two methods are described in detail later).

Teaching Methods

Before setting the teaching mode, you must first confirm the setting of the color mark mode or color mode. The green "COLOR" indicator light is always on for color mode, and off for color mark mode.

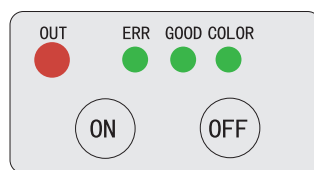

Two-point teaching setting method

① Press the "ON" button when the light projected by the sensor faces the color to be measured, and the green "GOOD" indicator flashes.

② Press the "OFF" button with the light projected by the sensor facing the background color.

③ When the threshold value set between steps ① and ② can be stably detected, the green indicator light "GOOD" is always on, indicating that the detection can be started normally.

When the threshold value set between steps ① and ② cannot be stably detected, the red indicator light "ERR" flashes for 3 seconds and then returns to the last setting state.

④ If you need to switch the output mode from NO (normally open) to NC (normally closed), you need to change the order of setting steps ① and ②.

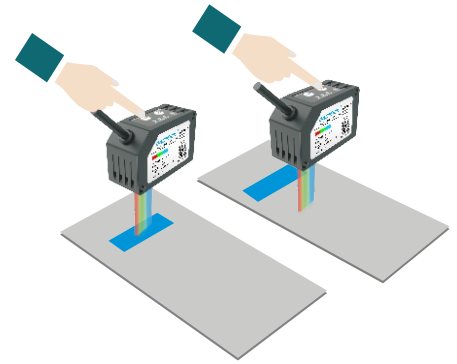

Threshold hysteresis adjustment

① Press the "ON" button for more than 5 seconds until the ERR, GOOD, and COLOR indicators flash simultaneously.

② Press the "OFF" button to adjust the hysteresis value.

The relationship between the hysteresis status and the flashing indicator light is as follows:

Status	Indicator Lights ○ ○ ○	Three indicator lights flashing
Small hysteresis value	○ ○ ●	Only the COLOR indicator light flashes
Medium hysteresis value	○ ● ●	GOOD and COLOR indicators flash at the same time
Large hysteresis value	● ● ●	ERR, GOOD, COLOR indicators flash at the same time

Exit threshold hysteresis adjustment

In the case of threshold hysteresis adjustment, press the "ON" button for more than 5 seconds until the ERR, GOOD, and COLOR indicators stop flashing and stay on, which means exiting the threshold hysteresis adjustment.

■ About error message prompts

When an error message appears, handle it as follows.

Indicator light status	The red "ERR" indicator is always on and will not turn off automatically.
Error message content	The output line load is short-circuited and overcurrent is flowing.
Handling	After turning off the power, check the output line load.

⚠ WARN

- This product is for target detection only. Do not use wood products for the purpose of protecting the human body or human body parts.
- This product cannot be used as an explosion-proof product. Do not use this product in hazardous locations or in environments with potentially explosive gases.
- This product is powered by DC. Do not use AC power. If AC voltage is applied, the product may explode or catch fire.