

Universal Square Photoelectric Sensor GF21 Series

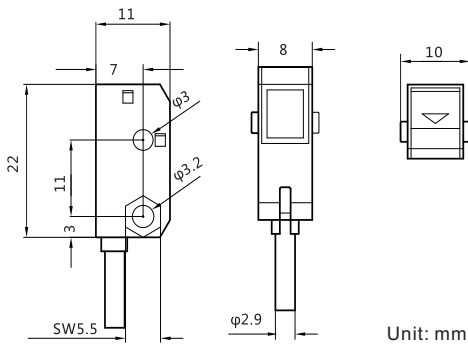

Appearance		
Type		Through-beam
Model	NPN output PNP output	GF21-150N-ZBA GF21-150P-ZBA
Detection distance		150cm
Output mode		NPN or PNP collector open circuit
Light source		Infrared LED (940nm)
Response time		<1ms
Working voltage		12-24V DC
Consumption current		<30mA
Load current		<100mA
Entry cable		2M/3-core cable
Protection level		IP40
Ambient temperature		-20 °C~+50 °C, no freezing
Environmental humidity		35%~85% RH, no condensation
Storage environment		-40 °C~+70 °C, no freezing
Protection circuit		Reverse polarity protection
Environmental luminosity		Sunshine exposure ≤ 10000Lux, incandescent lamp ≤ 3000Lux
Insulation strength		≥ 20M Ω/500V DC
Compressive strength		AC1000V (50/60Hz) for 1 minute
Vibration resistance		10~55Hz reciprocating amplitude 1.5mm, 2 hours in X, Y, Z directions
Impact resistance		500m/s ² X, Y, Z 3 times in each direction
NPN D.on (Lon)		NC(NO)
PNP D.on (L on)		PC(PO)

Size specifications



Circuit diagram

