

1.25mm 12-Pin +VCC+GND Cable For PNP Output V07

1.25mm 12-Pin

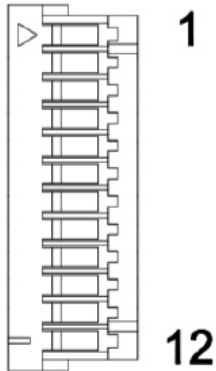

1	INPUT5/STANDBY	BROWN AND WHITE
2	SHIELD	YELLOW AND WHITE
3	OUTPUT COM+	PINK
4	OUTPUT1	PURPLE
5	OUTPUT2	GRAY
6	OUTPUT3	LIGHT BLUE
7	OUTPUT4	YELLOW
8	N.C.	BROWN
9	INPUT4	ORANGE
10	INPUT3	BLUE
11	INPUT2	WHITE
12	INPUT1	GREEN

Typical Connection

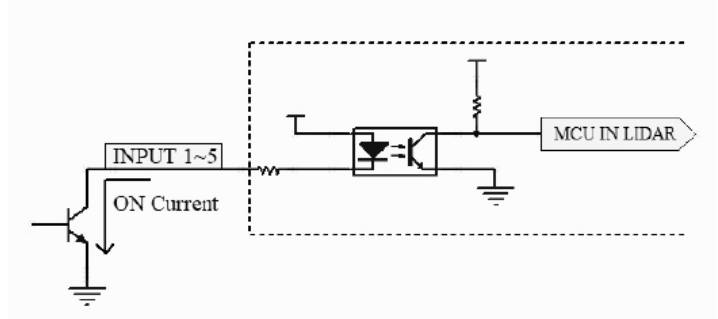

Naked wire

VCC	RED
VCC	RED AND WHITE
GND	BLACK
GND	BLUE AND WHITE

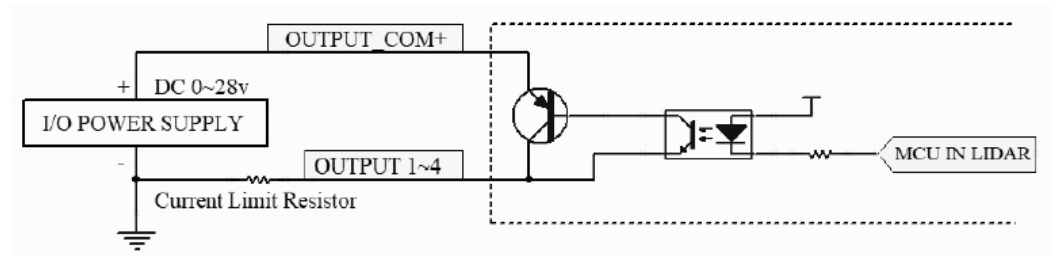

Note: INPUT should be Hi-Z or GND

Output Drive capability DC30V 50mA MAX

PNP wiring diagram

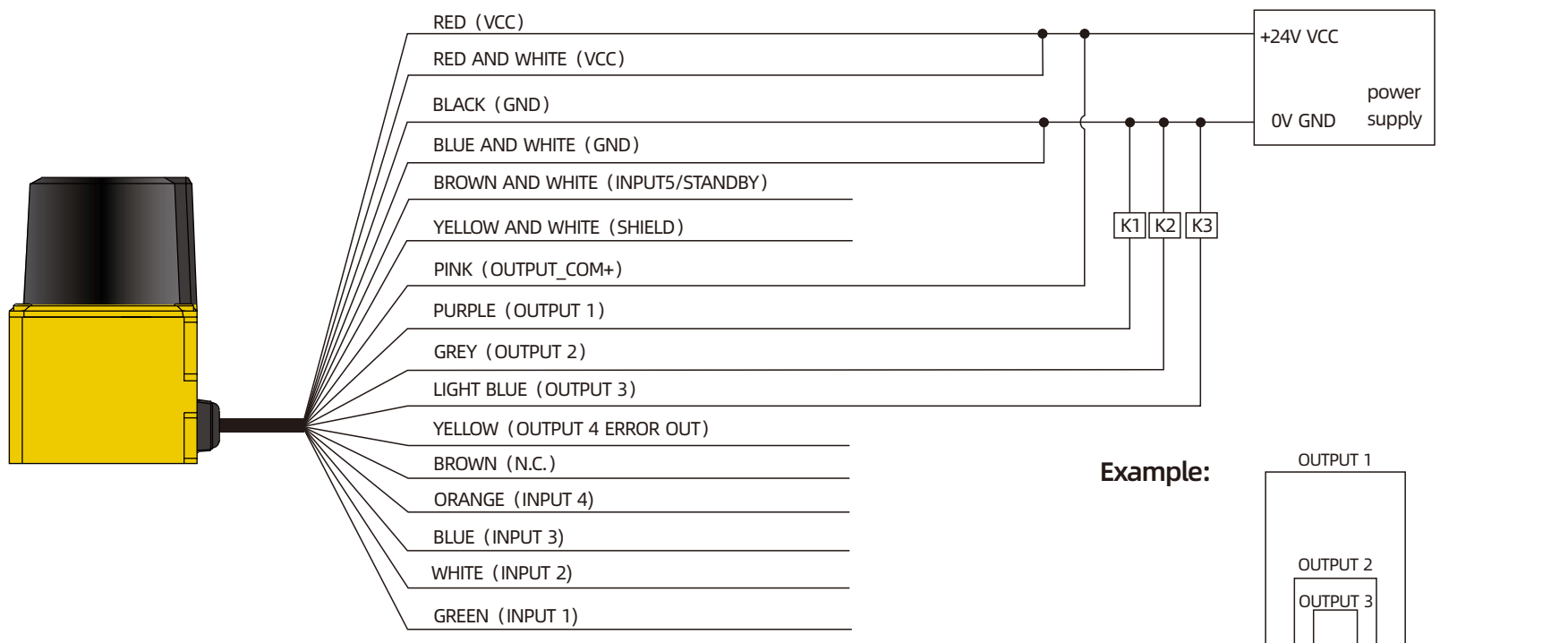

1.25mm 12-Pin +VCC+GND Cable For NPN Output V07

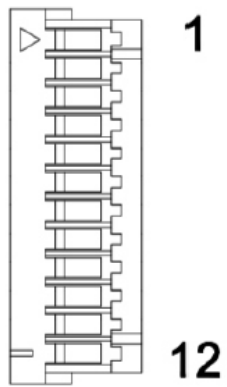

1.25mm 12-Pin

1	INPUT5/STANDBY	BROWN AND WHITE
2	SHIELD	YELLOW AND WHITE
3	OUTPUT_COM-	PINK
4	OUTPUT1	PURPLE
5	OUTPUT2	GRAY
6	OUTPUT3	LIGHT BLUE
7	OUTPUT4	YELLOW
8	N.C.	BROWN
9	INPUT4	ORANGE
10	INPUT3	BLUE
11	INPUT2	WHITE
12	INPUT1	GREEN

Naked wire

VCC	RED
VCC	RED AND WHITE
GND	BLACK
GND	BLUE AND WHITE

Typical Connection

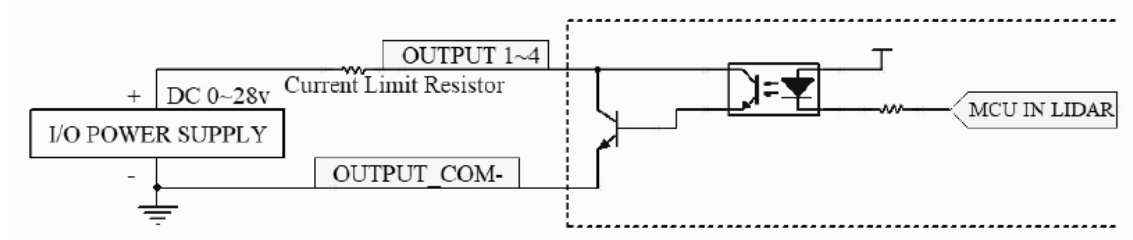
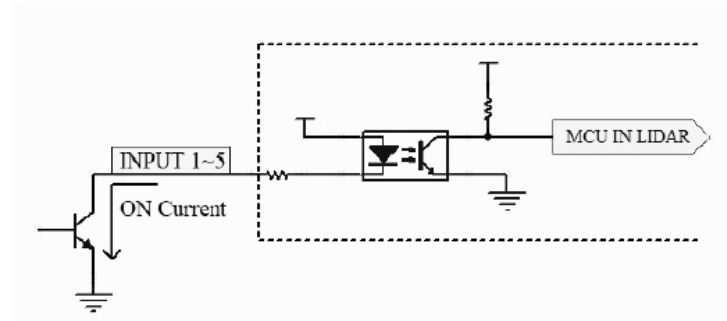

*Note: INPUT should be Hi-Z or GND
Output Drive capability DC30V 50mA MAX*

NPN wiring diagram

