

Hangzhou Welping Machinery Equipment Co., Ltd
Address: Room 1906 Building 1, Taifu Plaza, No. 1 Tonghui Middle Road, Xiaoshan District, Hangzhou, China
www.welpingtool.com Tel:0571-89332538 top@welping.cn

BREAKDOWN PART LIST WELPING WP160C2 MANUAL BUTT FUSION MACHINE

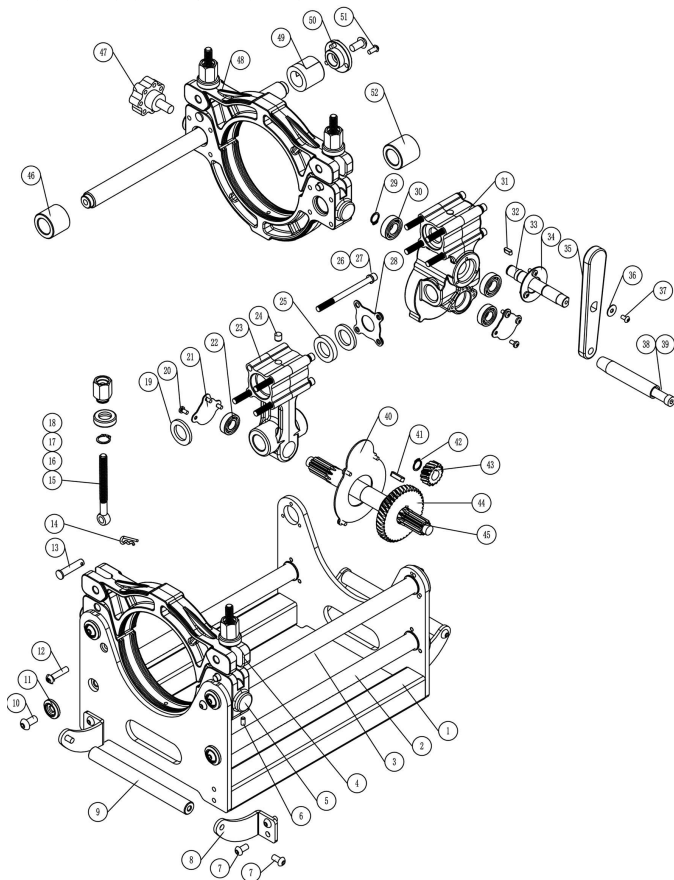

Part:Machine Frame



S/N	Part Description	Specification	Qty	S/N	Part Description	Specification	Qty
1	welded frame		1	27	pull rod	M8*110-30	8
2	teethed shaft		2	28	cover D	δ1.5	1
3	long shaft		2	29	retaining ring	Φ17	1
4	upper clamping part-left		2	30	bearing	6003-2RS	2
5	lower clamping part-left		1	31	gear housing B-75		1
6	screw	M6*12	2	32	flat key	5*14	1
7	screw	M8*16	12	33	rotating shaft		1
8	handle bracket	Q235A-5.0	2	34	cover A	δ1.5	1
9	frame handle		2	35	link rod	Q235B	1
10	screw	M10*20	8	36	spacer	φ 5	1
11	spacer	Q235B-10.0	4	37	screw	M5*10	13
12	screw	M8*35	2	38	handle sleeve		1
13	shaft pin	Φ10*45	4	39	screw post		1
14	R pin	3*35	4	40	cover B	δ1.5	1
15	lock bolt	T12*3-110, 45#	4	41	flat key	6*25	1
16	retaining ring	Φ18	4	42	retaining ring	Φ15	1
17	spacer		4	43	gear 15 teeth		1
18	nut	T12*3	4	44	gear 40 teeth		1
19	spacer	Φ40*Φ25*4	4	45	gear shaft		1
20	screw	M5*10	13	46	shaft sleeve A		2
21	cover C	δ1.5	2	47	screw	M12*25	1
22	bearing	6002-2RS	2	48	lower clamping part-right		1
23	gear housing A-75		1	49	shaft sleeve C		1
24	grease fitting	Φ10*10	2	50	flange stub		4
25	press cover		2	51	screw	M6*14	12
26	spring washer	Φ8	8	52	shaft sleeve B		1

Planing tool (Trimmer, Facer)

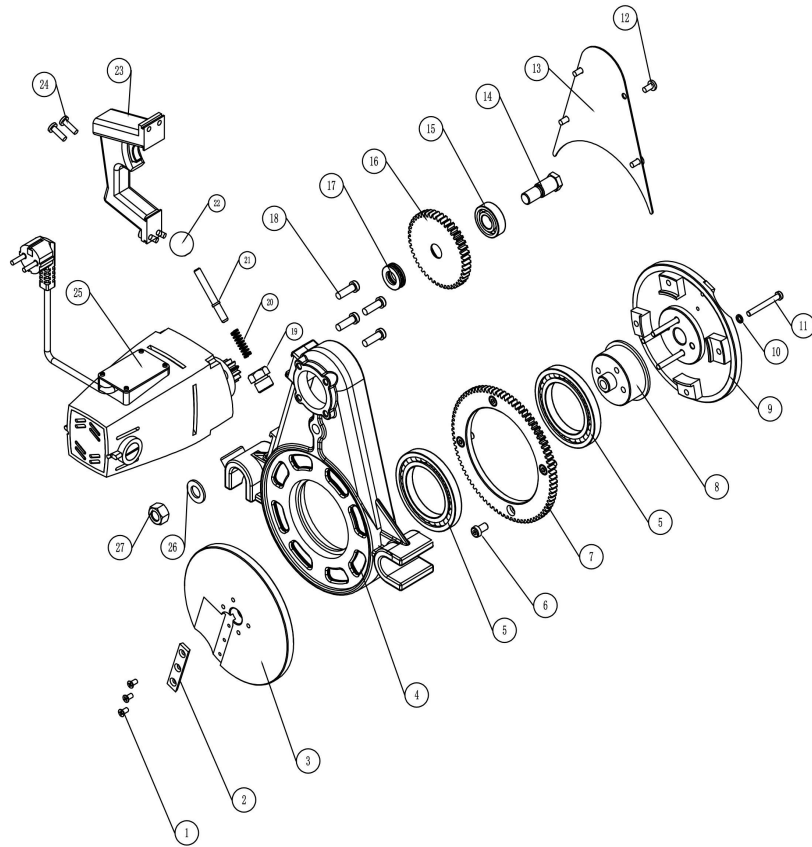

S/N	Part Description	Specification	Qty
1	screw	M5*10	6
2	blade	HSS	2
3	planing plate right		1
4	planing tool frame		1
5	bearing	16013	2
6	screw	M8*14	4
7	gear ring	40Cr	1
8	solid coupling		1
9	planing plate left		1
10	spring washer	Φ6	4
11	screw	M6*50	4
12	screw	M6*12	4
13	cover	δ1.2	1
14	bridge shaft	45#	1
15	bearing	6203-2RS	1
16	bridge gear	40Cr	1
17	thrust bearing	51103	1
18	screw	M8*25	4
19	nut		1
20	compression spring	∅0.9*10*33*8N	1
21	pull pin		1
22	knob	M8	1
23	handle		1
24	screw	M6*20	4
25	motor	16A	1
26	flat washer	Φ14	1
27	nut	M14	1

planing tool complete

Heating plate

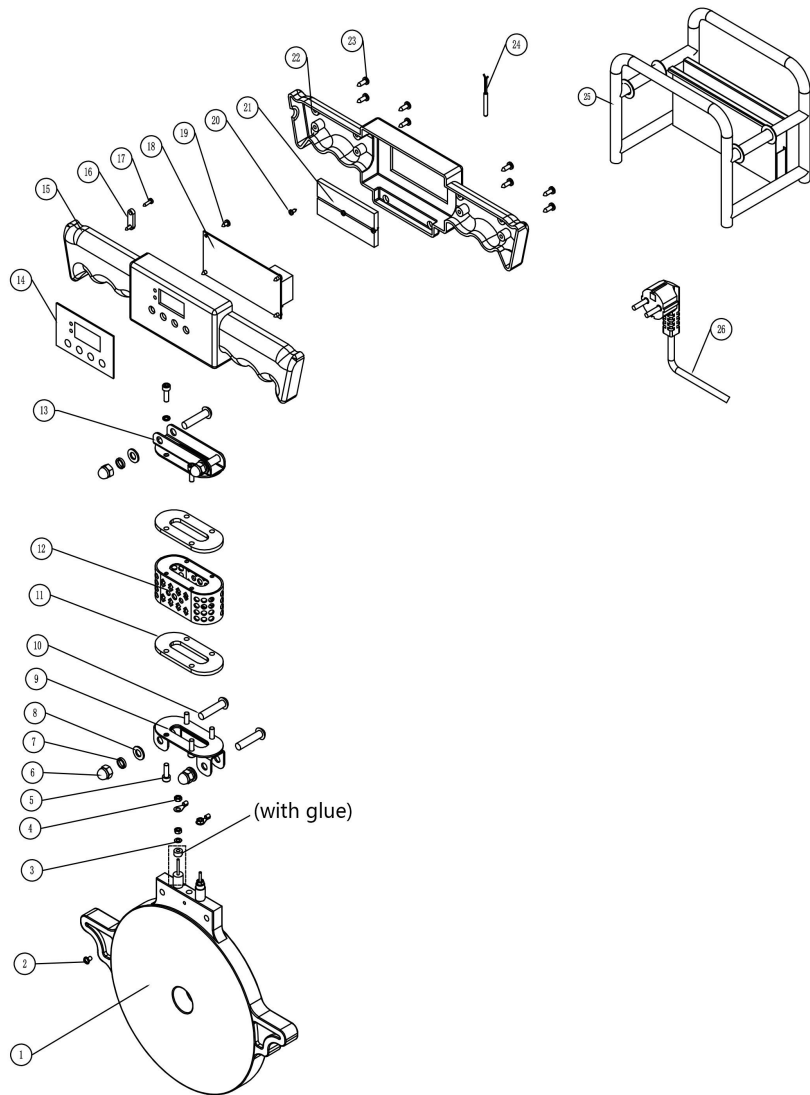

S/N	Part Description	Specification	Qty
1	plate casting		1
2	screw	M4*6	1
3	flat washer	Φ4	2
4	nut	M4	4
5	screw	M5*16	8
6	nut	M8	4
7	spring washer	Φ8	2
8	flat washer	Φ8	4
9	cassette A		1
10	screw	M8*35	4
11	heat insulation washer		2
12	heat dissipation case	∅1.8	1
13	cassette B		1
14	screen plate	82*53	1
15	front handle grip	ABS	1
16	wire clamping plate	A53	1
17	screw	ST3*12	2
18	PPR digital display		1
19	screw	ST3.5*8	4
20	screw	ST3*8	3
21	heat dissipation plate	6061	1
22	rear handle grip	ABS	1
23	screw	ST4*12	8
24	thermocouple	Φ 4*50	1
25	tool basket		1
26	power cord		1
heating plate complete			