

Hangzhou Welping Machinery Equipment Co., Ltd
Address: Room 1906 Building 1, Taifu Plaza, No. 1 Tonghui Middle Road, Xiaoshan District, Hangzhou, China
www.welpingtool.com Tel:0571-89332538 top@welping.cn

BREAKDOWN PART LIST WELPING WP200C MANUAL BUTT FUSION MACHINE

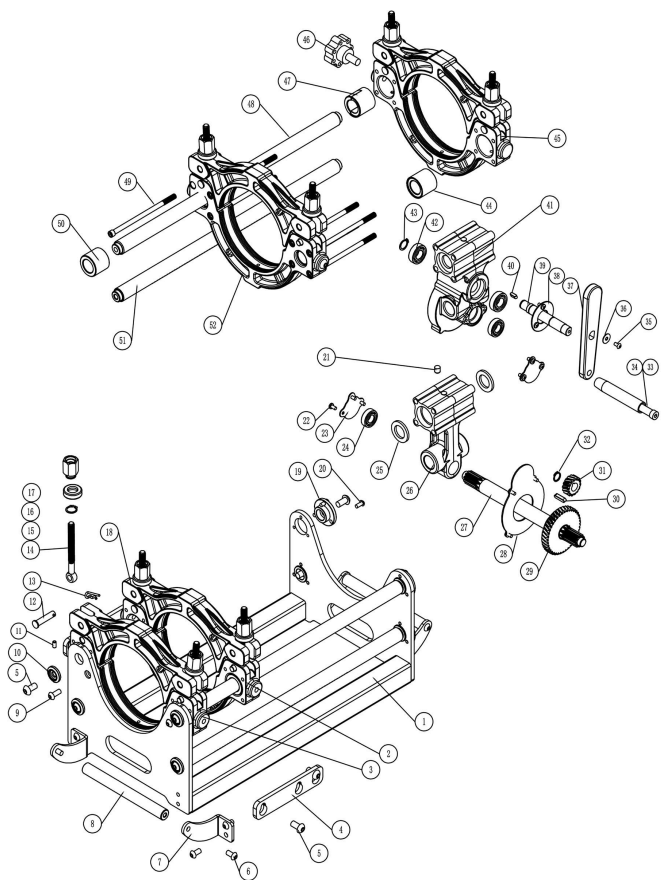

Part:Machine Frame



S/N	Part Description	Specification	Qty	S/N	Part Description	Specification	Qty
1	Welded frame		1	27	gear shaft		1
2	Lower clamping part B		1	28	cover B		1
3	Lower clamping part A		1	29	gear		1
4	Link	Q235B-8.0	2	30	flat key	6*25	1
5	screw	M10*20	14	31	gear		1
6	screw	M8*16	12	32	retaining ring	Φ15	1
7	handle bracket		2	33	sleeve		1
8	handle rod		2	34	screw rod		1
9	screw	M8*35	2	35	screw	M5*10	13
10	spacer		4	36	washer	φ 5	1
11	screw	M6*16	4	37	handle link		1
12	pin	Φ10*45	8	38	cover A		1
13	R-pin	3*35	8	39	handle shaft		1
14	lock bolt	T12*3	8	40	flat key	5*14	1
15	retaining ring	Φ18	8	41	gear housing B		1
16	washer		8	42	bearing	6003-2RS	2
17	nut	T12*3-110	8	43	retaining ring	Φ17	1
18	upper clamping part		4	44	sleeve B		3
19	flange stub		4	45	Lower clamping part D		1
20	screw	M6*14	12	46	screw	M12*2555	1
21	grease fitting	Φ10*10	2	47	sleeve C		1
22	screw	M5*10	13	48	long shaft	Ø25	2
23	cover C		2	49	pull rod	M8*155-30	8
24	bearing	6002-2RS	2	50	sleeve A		4
25	spacer	Φ40*Φ25*4	4	51	gear shaft		2
26	gear housing A		1	52	Lower clamping part C		1

Planing tool (Trimmer, Facer)

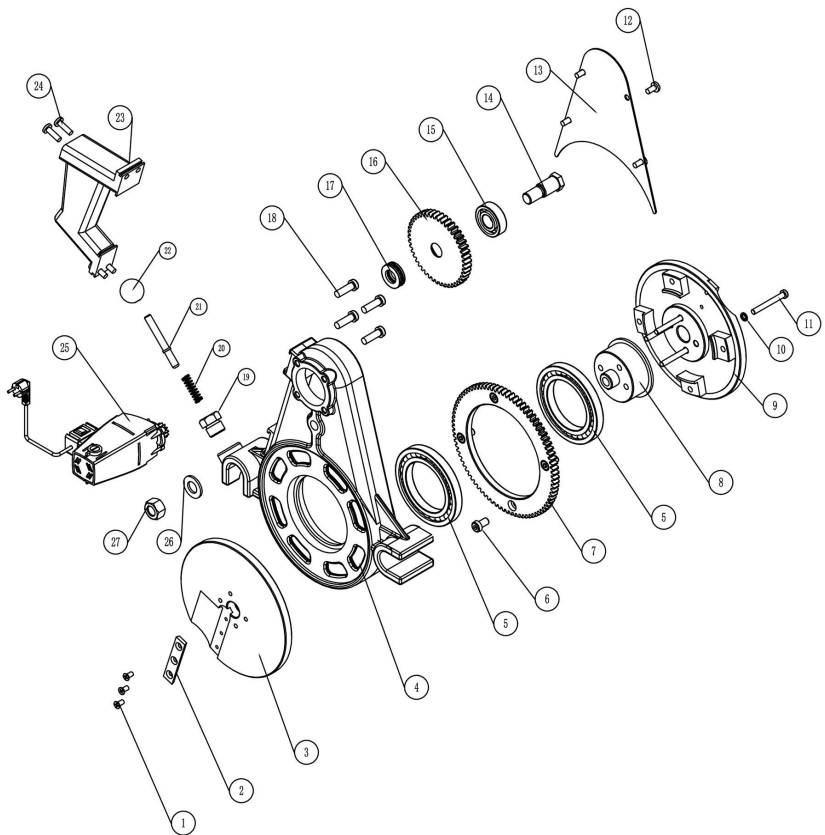

S/N	Part Description	Specification	Qty
1	screw	M5*10	6
2	blade	HSS	2
3	planing plate right		1
4	planing tool frame 200mm		1
5	bearing	16013	2
6	screw	M8*14	4
7	gear ring		1
8	solid coupling		1
9	planing plate left		1
10	spring washer	Φ6	4
11	screw	M6*50	4
12	screw	M6*12	4
13	cover		1
14	bridge shaft		1
15	bearing	6203-2RS	1
16	bridge gear		1
17	thrust bearing	51103	1
18	screw	M8*25	4
19	nut		1
20	compression spring	∅0.9*10*33*8N	1
21	pull pin		1
22	knob	M8	1
23	handle		1
24	screw	M6*20	4
25	motor	16A, 12 teeth	1
26	flat washer	Φ14	1
27	nut	M14	1

planing tool complete

Heating plate

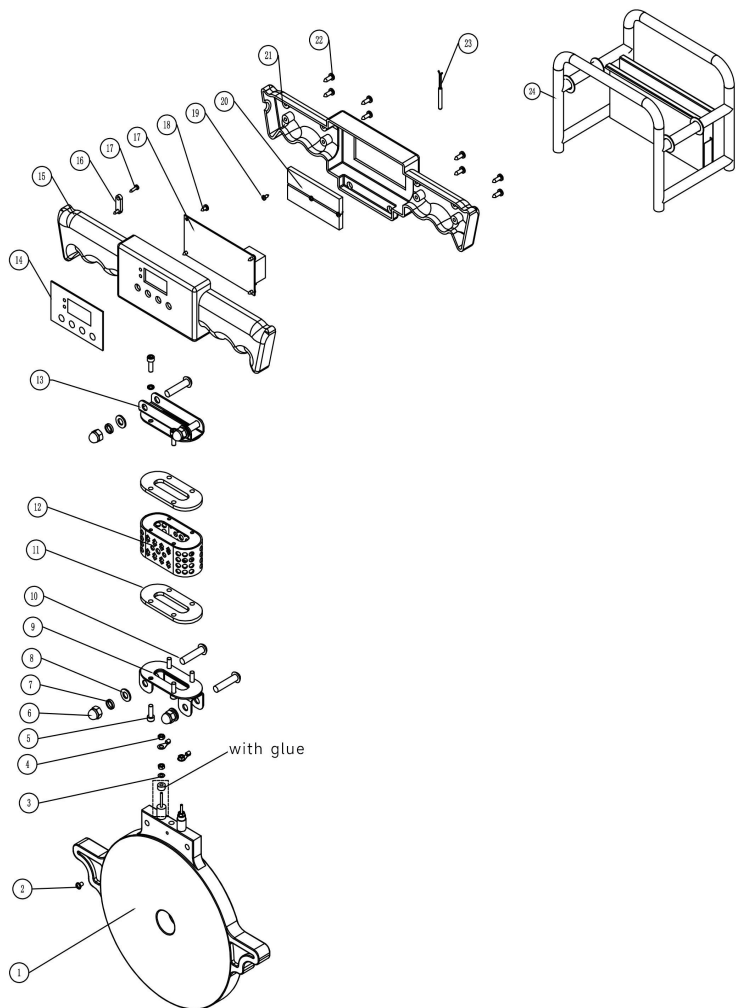

S/N	Part Description	Specification	Qty
1	plate casting		1
2	screw	M4*6	1
3	flat washer	Φ4	2
4	nut	M4	4
5	screw	M5*16	8
6	nut	M8	4
7	spring washer	Φ8	2
8	flat washer	Φ8	4
9	cassette A		1
10	screw	M8*35	4
11	heat insulation washer		2
12	heat dissipation case	δ1.8	1
13	cassette B		1
14	screen plate	82*53	1
15	front handle grip	ABS	1
16	wire clamping plate	A53	1
17	screw	ST3*12	2
18	PPR digital display		1
19	screw	ST3.5*8	4
20	screw	ST3*8	3
21	heat dissipation plate	6061	1
22	rear handle grip	ABS	1
23	screw	ST4*12	8
24	thermocouple	Φ 4*50	1
25	tool basket		1
26	power cord		1
heating plate complete			