

# Built-In or Free Standing Beer Cooler

## Model: ZS-A150P

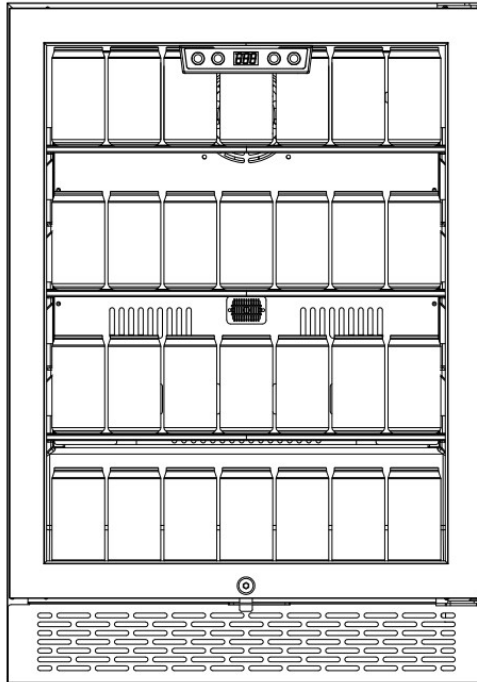

## USE & CARE

Introduction.....	2
Important Safety Information.....	3-4
Installation Instructions .....	5
Grounding Instructions.....	6
Features .....	7
Temperature Controls.....	8
Display .....	9
Troubleshooting .....	10
Limited Warranty .....	11

## 2 INTRODUCTION

This manual is your resource for the use and care of your product. Please read it before using your appliance. Keep it handy for quick reference. If something does not seem right, the troubleshooting section will help you with common issues.

We are here for you ! visit our website, chat with an agent, or call us if you need help. We may be able to help you avoid a service visit. If you do need service, we can get that started for you.

Let's make it official ! Be sure to register your product.

Keep your product info here so it's easy to find.

Model Number \_\_\_\_\_

Serial Number \_\_\_\_\_

Purchase Date \_\_\_\_\_

Welcome to

### Installation Checklist

#### Door

Handle is secure and tight

Door seal completely to cabinet on all sides

#### Leveling

Keep the front and back level for cooler

Cabinet is setting solid on all corners

#### Electrical power

House power turned on

Beverage cooler plugged in

#### Final checks

Shipping material removed

Temperature setting

### **3 IMPORTANT SAFETY INFORMATION**

#### **PLEASE FOLLOW THE PRECAUTIONS BELOW FOR YOUR NEW COOLER**

1.This refrigerator must be properly installed and located in accordance with the installation instructions before it is used.

2.Do not allow children to climb, stand or hang on the shelves in the cooler. They could damage the cooler and seriously injure themselves.

3.Do not store or use gasoline or other flammable vapors and liquids in the vicinity of this or any other appliance.

4.Keep finger out of the clearances between the doors and cabinet.Be careful closing doors when children are in the area.

5.Unplug the cooler before cleaning and making repairs.

6.We strongly recommend that any servicing be performed by a qualified individual.

7. Do not leave cooler in extreme cold or warm temperatures.

8. Do not place cooler near heat sources or open flames.

9. Clean the cooler with a soft, damp cloth. Remove stains with a mild soap.

Do not clean the unit with industrial grade solvents, or abrasive chemicals.

10. Do not place heavy items on top of the cooler.

11. Never install the cooler where there is a lot of moisture and water can splash.

12. Do not allow children to hang on the doors; the cooler may be tipped over and hurt children.

13. Never eat spoiled food stored too long in the cooler or in an out-of-order cooler

14. Do not use sharp tools inside the cooler-for example-to remove ice as damage may occur.

15. Unplug and remove food from the cooler if not used for a long period of time.

#### **Proper Disposal**

An empty cooler is an extremely dangerous attraction to children. If you are getting rid of your old cooler, pls follow the instructions in the Child Entrapment Warning.

#### **Child Entrapment Warning**

Risk of child entrapment. Before you throw away your old cooler or freezer:

1. Take of the doors.

2. Leave the shelves in place so that children may not easily climb inside.

**CAUTION:USE OF AN EXTENSION CORD IS NOT RECOMMENDED  
FOR HOUSEHOLD USE ONLY SAVE THESE INSTRUCTIONS**

## 4 IMPORTANT SAFETY INSTRUCTIONS

### IMPORTANT SAFETY INSTRUCTIONS

(1) **WARNING:** To reduce the risk of electrical shock, or injury when using your appliance, follow these basic precautions:

(2) Read all instructions before using the Cooler.

(3) **DANGER or WARNING:** Risk of child entrapment Cooler.

(4) Junked or abandoned appliances are still dangerous.. even if they will just sit in the garage a few days.

(5) Before you throw away your old Beverage Cooler: Take off the door.

(6) Leave the shelves in place so that children may not easily climb inside.

(7) Never allow children to operate, play with, or crawl inside the appliance.

(8) Never clean appliance parts with flammable liquids. The fumes can create hazard or explosion.

(9) Do not store or use gasoline or any other flammable apors and liquids in the vicinity of this or any other appliance. The fumes can create a rehazard or explosion.

(10) Do not repair or replace any part of the beverage cooler or attempt any servicing unless specially recommended in the user-maintenance instructions or in published user-repair instructions.

Replace the fuse with the same type.

-Save these instructions-

## 5 INSTALLATION INSTRUCTIONS

### Before Using Your Product

Remove the exterior and interior packing.

Check to be sure you have all of the following parts:

MODEL: ZS-A150P

- ① Instruction Manual x 1
- ② Glass shelf x 3
- ③ Keys x 2
- ④ Stainless Steel Handle x1

### INSTALLATION THE HANDLE

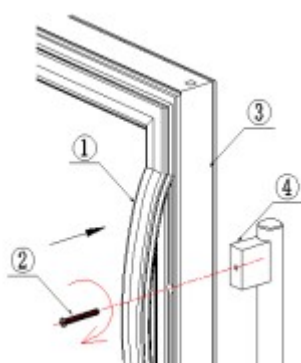

① First remove the gasket from the groove of the door ② Insert the screws into the hole on the door align the screw hole on the handle tighten the handle screws in the direction shown as the arrow

③ Install the gasket into the door groove of the body profile.

④ Double checking the interval between the gasket & cabinet fixed properly.

**(CHECK EASIER WITH INTERIOR LIGHT ON)**

**CAUTION: LEAKING AIR WILL CAUSE DAMAGE THE COMPRESSOR**

### HOW TO BUILT IN

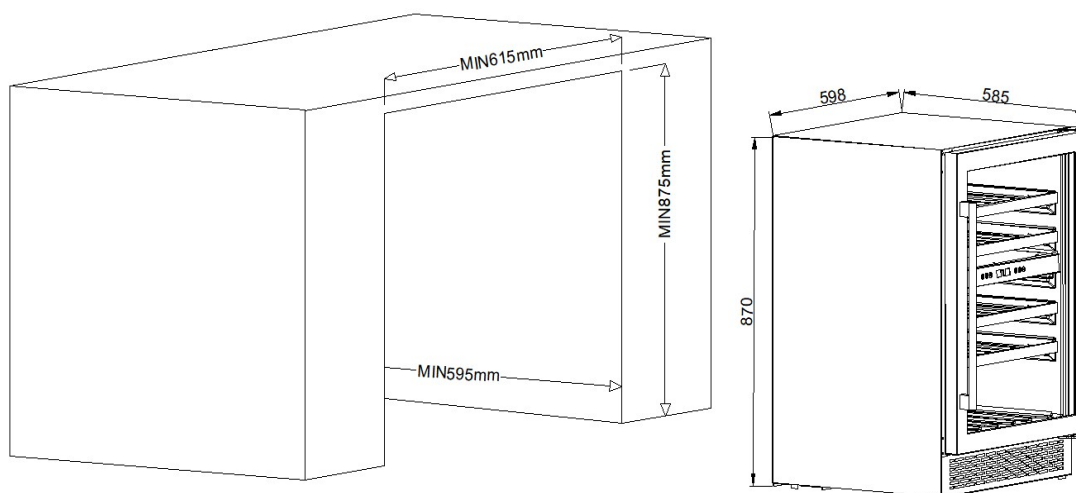

## 6 GROUNDING INSTRUCTIONS

This appliance must be grounded. In the event of an electrical short circuit, grounding reduces the risk of electric shock by providing an escape wire for the electric current. This appliance is equipped with a cord having a grounding wire with a grounding plug. The plug must be inserted into an outlet that is properly installed and grounded.

### WARNING

Improper use of the grounding plug can result in a risk of electric shock. Consult a qualified electrician or service person if the grounding instructions are not completely understood, or if doubt exists as to whether the appliance is properly grounded.

If it is necessary to use an extension cord, use only a three wire extension cord that has a three blade grounding plug, and a three slot receptacle that will accept the plug on the appliance. The marked rating of the extension cord should be equal to or greater than the electrical rating of the appliance.

### INSTALLATION

#### 1. Steady, flat location.

If the refrigerator is not leveled during installation, the doors may not close or seal properly, causing cooling, frost, or moisture problems. It is very important for the refrigerator to be level in order to function properly. To level your refrigerator, you may either turn the level leg clockwise to raise that side of the refrigerator or turn counter-clockwise to lower that side. Having someone push against the top of the refrigerator will take some weight off the leveling leg. This makes it easier to adjust the leveling leg.

#### 2. Ventilation;

Place refrigerator approximately 5 inches from the wall to ensure proper airflow to the compressor. Do not place refrigerator near any heat resources such as a heater or stove as it will put a strain on the power supply.

#### 3. Power supply.

Check your local power source. This refrigerator requires a 110V-120V,60Hz power supply.

Use a receptacle that will accept the ground prong. The power cord of this appliance is equipped with a 3-prong(grounding) plug which mates with a standard 3-prong(grounding) wall outlet to minimize the possibility of electric shock hazard from this appliance.

(a) Longer cord sets or extension cords are available and may be used if care is exercised in their use.

(b) If a long cord or extension cord is used,(1) the marked electrical rating of the cord set or extension cord should be at least as great as the electrical rating of the appliance,(2) the extension cord must be a grounding-type 3-wire cord, and(3) the longer cord should be arranged so that it will not drape over the counter, top or table top where it can be pulled on by children or tripped over unintentionally.

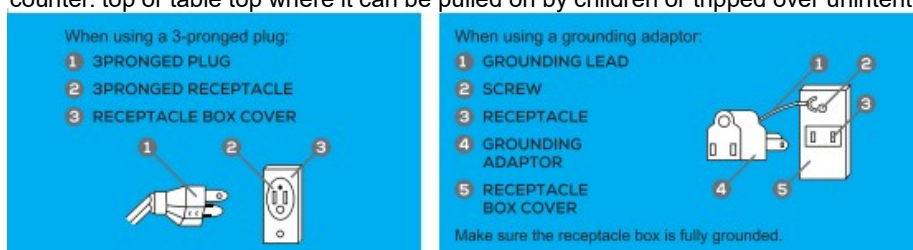

## 7 FEATURES

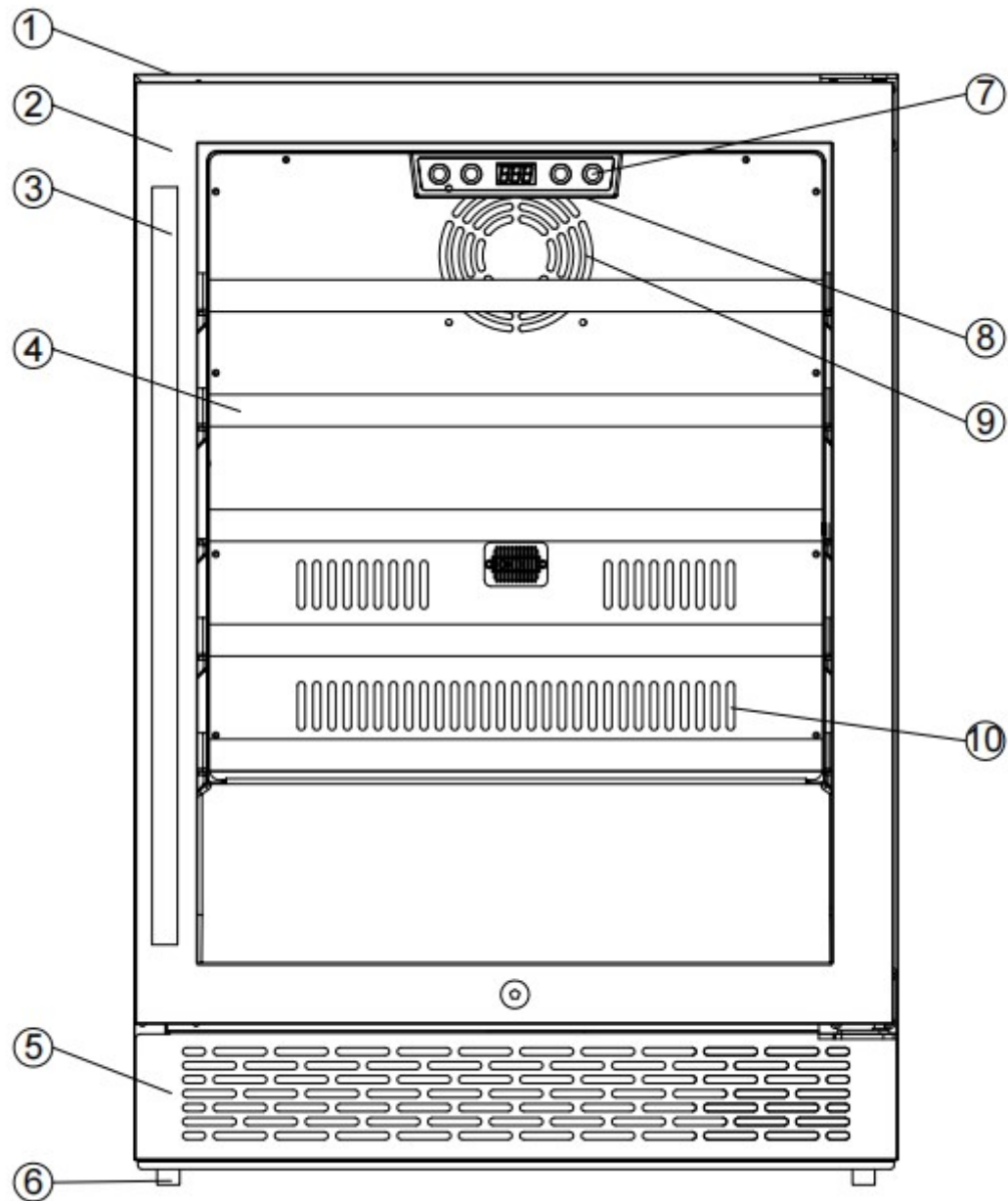



- ① Box body
- ② Glass door
- ③ handle
- ④ Shelf
- ⑤ Metal cover
- ⑥ Adjustable leg
- ⑦ Control display
- ⑧ LED light
- ⑨ Refrigeration position
- ⑩ Cold air circulation position

## 8 TEMPERATURE CONTROLS

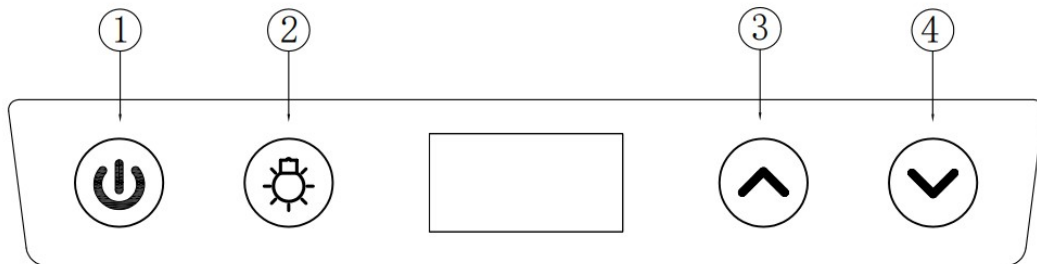
### Operation Panel





#### 1. Control panel:



① Power on/off  : In the off state, touch this button to turn on the power, and in the on state, press and hold  keys for 3 seconds to turn off the power;

② LED light on/off  : touch this button to control the LED light on/off;

③ Incremental temperature setting key  : touch this key to increase the temperature setting;

④ Temperature decrement setting key  : touch this key to set the temperature decrement;

Celsius/Fahrenheit switching function: Press  and  at the same time for 3 seconds to switch Fahrenheit and Celsius;

Child lock function: press  and  at the same time for 3 seconds to lock, and all the keys will be locked after being locked. After locking, press  two buttons again for 3 seconds to unlock.

### Operation For Temperature

Temperature Range: -5°C-10°C  
23°F-50°F



## 9 DIAPLAY

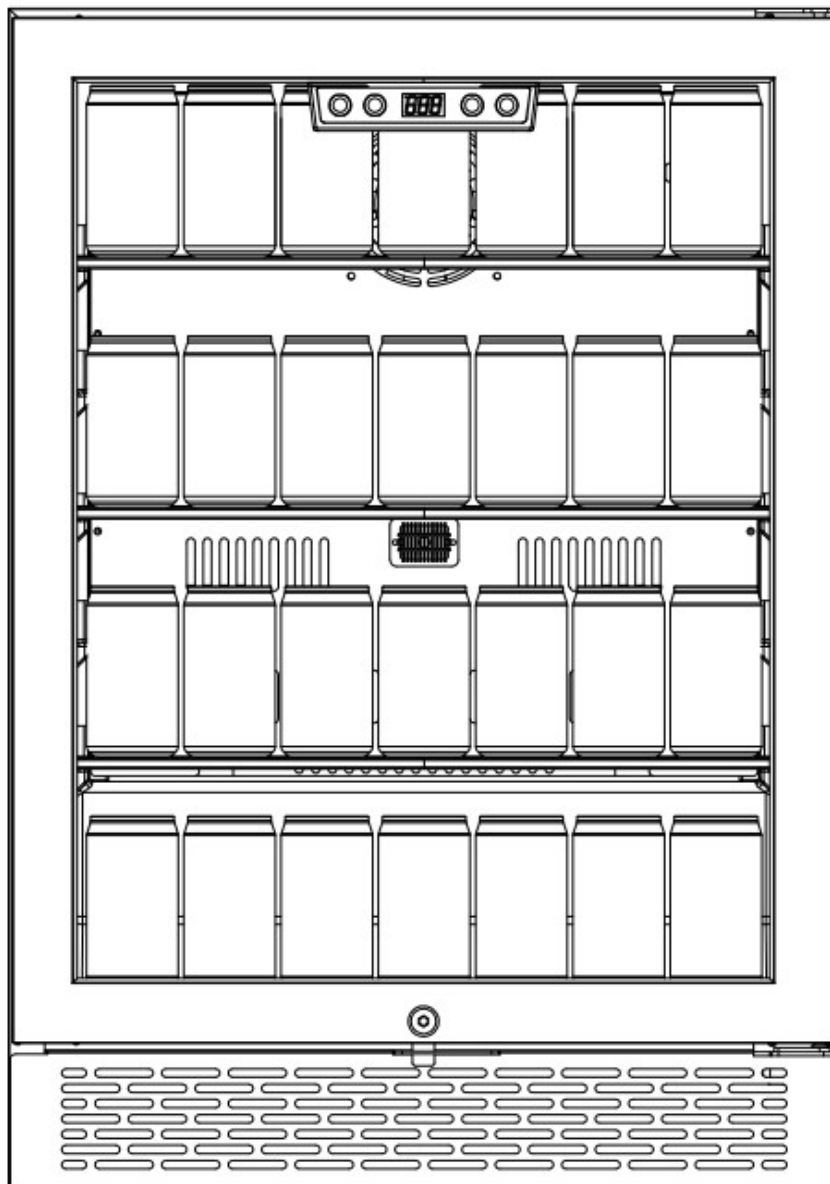

### TECHNICAL SPECIFICATIONS

Unit Dimention (WxDxH) (cm):	59.8 x 58.5 x 87.0
Power Supply :	AC230V ~ 50Hz
Current :	1.0A
Net capacity :	148L
Lighting Power :	1W
Refrigerant :	R600a / 32g
Foaming Agent :	Cyclopentane

## 10 TROUBLE SHOOTING

If the refrigerator will not operate:if

The power supply cord is unplugged.

The electronic control is set to the position.

A household fuse or circuit breaker has tripped.

If the beverage in the refrigerator compartment is freezing:

The electronic control is set too cold or too closed to the coil.

If the beverage in the compartment is not cold:

The air vents on the drip tray are blocked in the compartment;this prevents the movement of cold air.

The door is opened too often or not closed properly.

A large amount of drinks or foods had just been added to the refrigerator or cooler compartment.

The position of thermostat knob is adjusted too low.

If the refrigerator seems to make unusual noise:

The refrigerator is not leveled on the floor.

The body of the refrigerator touches a wall.

The drip tray is not placed properly.

If there is interior moisture build-up:

The door is opened too often or not closed properly.

The room is humid.

If the door will not close completely:

The shelves are out of position.

The gaskets are dirty.

The refrigerator is not level.

## **11 LIMITED WARRANTY**

To make a warranty claim, do not return this product to the store.

Please email support

### **1 Year warranty**

This product is warranted to be free from defects in material and workmanship for a period of one(1) year from the date of original purchase. During this period, your exclusive remedy is repair or replacement of this product or component found to be defective, at our option; however, you are responsible for all costs associated with returning the product to us. If the product or component is no longer available, we will replace with a similar one of equal or greater value. Prior to a replacement being sent, the product must be rendered inoperable or returned to us.

This warranty does not cover glass, filters, wear from normal use, use not in conformity with the printed directions., or damage to the product resulting from accident, alteration, abuse, or misuse. This warranty extends only to the original consumer purchaser or gift recipient. Keep the original sales receipt, as proof of purchase is required to make a warranty claim. This warranty is void if the product is used for other than single-family household use or subjected to any voltage and waveform other than as on the specified rating on the label(e.g.,220V-50Hz).

We exclude all claims for special, incidental, and consequential damages caused by breach of express or implied warranty. All liability is limited to the amount of the purchase price. Every implied warranty, including any statutory warranty or condition of merchant ability or fitness for a particular purpose, is disclaimed except to the extent prohibited by law, in which case such warranty or condition is limited to the duration of this written warranty. This warranty gives you specific legal rights. You may have other legal rights that vary depending on where you live. Some states or provinces do not allow limitations on implied warranties or special, incidental, or consequential damages, so the foregoing limitations may not apply to you.

For faster service, locate the model, type, and serial numbers on your appliance.

Our home is your home. Visit us if you need help with any of these things:

