

Continuous Innovation

- Over 20 professional engineers
- Over 3% continuous investment per year

On-time Delivery

- 1,100,000 units
(annual production capacity)

Greaidea®
Gas Hob & Water Heater ODM Leader
Since 2000

Reliable Quality

- 7 Inspection positions
- National standard testing lab

Professional Logistics

- Export to over 49 countries
- 500 containers delivery per year



Greaidea Gas and Electrical Appliances Co.,Ltd

Address: Building A, Shuntai Industry Park, No.2 Huajin Street,
Nantou town, Zhongshan city, GD, China.

Web: www.greaidea.com / www.cehob.com

Email: info@greaidea.com



EU

Product Catalog

20+ Years Experience
Your First Choice

**BATH & COOK
APPLIANCES**

About Us

Over 20 Years Of OEM & ODM Experience In Gas Hob, Range Hood and Gas Water Heater

- OEM & ODM gas hob, gas water heater and range hood since 2000.
- Established in 2000, the past over 20 years witnessed great chances of our product, R&D, quality level, and service as well. From now on, Greaidea has its own two production bases with over 500 employees, covering 100,000m². In order to meet the growing marketing needs, we have equipped with 10 assembly lines for gas hob and range hood, 5 assembly lines for gas water heater.

20⁺Y
Since 2000

2
Production bases

500+
Staffs

100,000m²
Area

15
Assembly lines

Kitchen Appliance Division

Greaidea has over 20 year's experience in manufacturing high quality gas hob and range hood. Our factory locates in Nantou town, Zhongshan city. In our R&D department, 16 engineers are employed to guarantee our R&D advantage and continuous improvement. Every year, 3% of revenue will be invested to R&D . With excellent manufacturing team & QC team, we can realize the annual output 800,000pcs gas hob and 300,000pcs range hood product with optimal quality.

Gas hob : 800,000 pcs / year
Range hood : 300,000 pcs / year

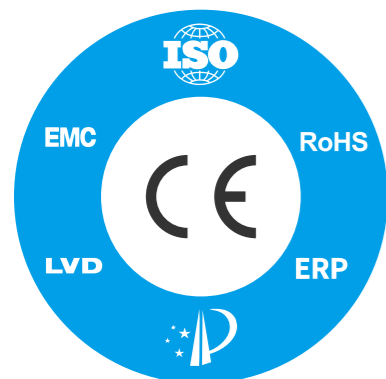

Final Assembly Line



► Online Key Position : 7 Times Inspection



Strict QC System

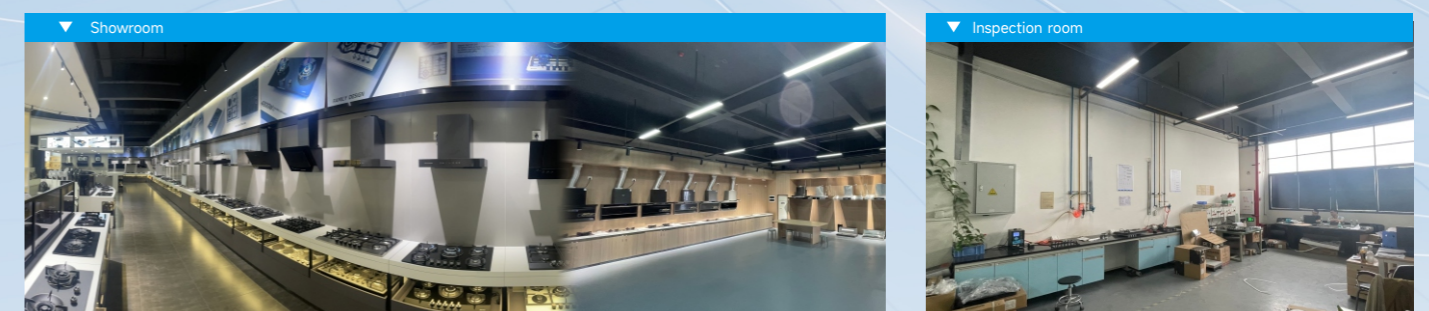
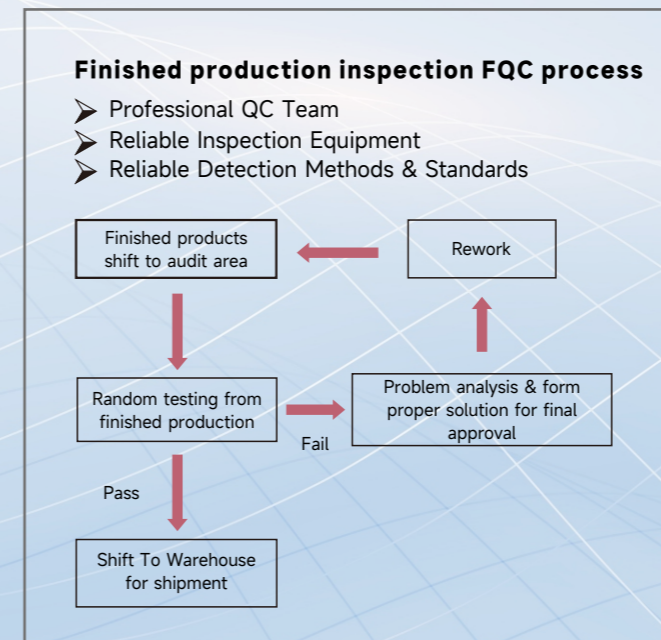
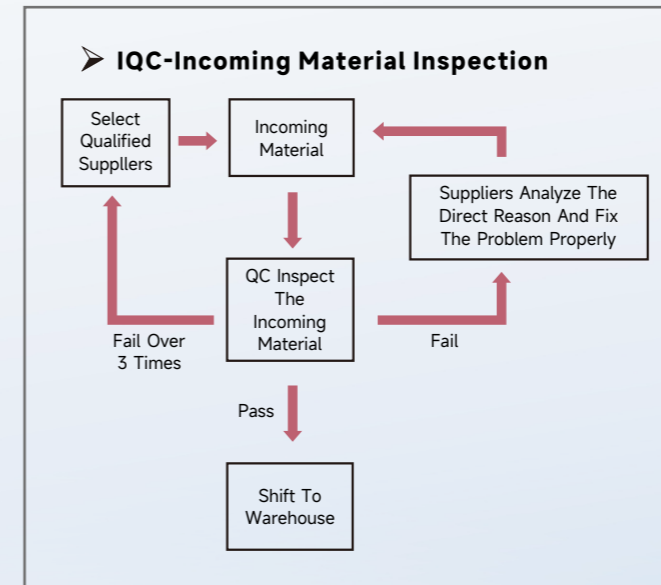

GLASS SERIES (CAST IRON)

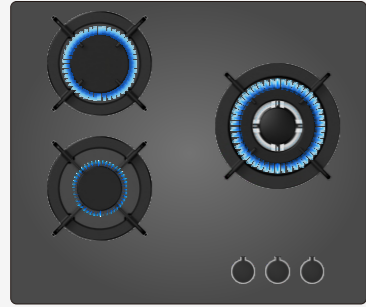

MGBG-603 BL ● / WH ○ / IV ○

Panel	Tempered glass
Panel Support	Cast iron
Knob Material	Metal
Heat Power(KW)	1.75 / 2.7 / 3.3
Optional	Safety device (FFD)
Product Size (mm)	600 (W) x 510 (D) x 110 (H)
Cut-out Size (mm)	560 (W) x 480 (D)
Packing Size (mm)	640 (W) x 540(D) x 150 (H)
Loading (20'/40'/40HQ)	540/1120/1310

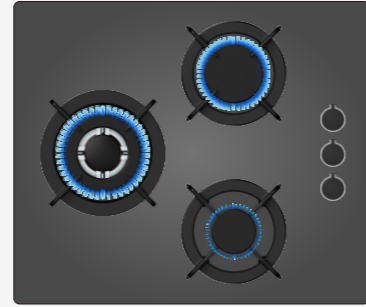

MGBG-603C BL ● / WH ○ / IV ○

Panel	Tempered glass
Panel Support	Cast iron
Knob Material	Metal
Heat Power(KW)	1.75 / 2.7 / 3.3
Optional	Safety device (FFD)
Product Size (mm)	600 (W) x 510 (D) x 110 (H)
Cut-out Size (mm)	560 (W) x 480 (D)
Packing Size (mm)	640 (W) x 540(D) x 150 (H)
Loading (20'/40'/40HQ)	540/1120/1310

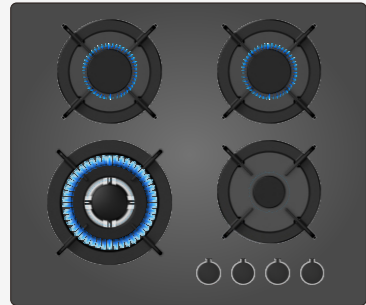

MGBG-604 BL ● / WH ○ / IV ○

Panel	Tempered glass
Panel Support	Cast iron
Knob Material	Metal
Heat Power(KW)	1.0 / 1.75 / 1.75 / 3.3
Optional	Safety device (FFD)
Product Size (mm)	600 (W) x 510 (D) x 110 (H)
Cut-out Size (mm)	560 (W) x 480 (D)
Packing Size (mm)	640 (W) x 540(D) x 150 (H)
Loading (20'/40'/40HQ)	540/1120/1310

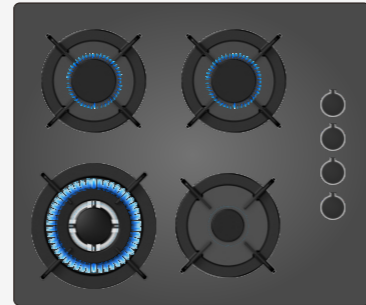

MGBG-604C BL ● / WH ○ / IV ○

Panel	Tempered glass
Panel Support	Cast iron
Knob Material	Metal
Heat Power(KW)	1.0 / 1.75 / 1.75 / 3.3
Optional	Safety device (FFD)
Product Size (mm)	600 (W) x 510 (D) x 110 (H)
Cut-out Size (mm)	560 (W) x 480 (D)
Packing Size (mm)	640 (W) x 540(D) x 150 (H)
Loading (20'/40'/40HQ)	540/1120/1310



GLASS SERIES (ENAMEL WIRE)



MGBG-603E BL ● / WH ○ / IV ○

Panel	Tempered glass
Panel Support	Enamel Wire
Knob Material	Bakelite
Heat Power(KW)	1.75 / 2.7 / 3.3
Optional	Safety device (FFD)
Product Size (mm)	600 (W) x 510 (D) x 110 (H)
Cut-out Size (mm)	560 (W) x 480 (D)
Packing Size (mm)	640 (W) x 540(D) x 150 (H)
Loading (20'/40'/40HQ)	540/1120/1310

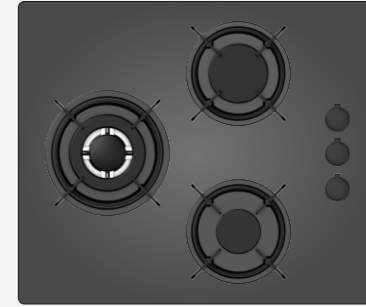

MGBG-603CE BL ● / WH ○ / IV ○

Panel	Tempered glass
Panel Support	Enamel Wire
Knob Material	Bakelite
Heat Power(KW)	1.75 / 2.7 / 3.3
Optional	Safety device (FFD)
Product Size (mm)	600 (W) x 510 (D) x 110 (H)
Cut-out Size (mm)	560 (W) x 480 (D)
Packing Size (mm)	640 (W) x 540(D) x 150 (H)
Loading (20'/40'/40HQ)	540/1120/1310



MGBG-604E BL ● / WH ○ / IV ○

Panel	Tempered glass
Panel Support	Enamel Wire
Knob Material	Bakelite
Heat Power(KW)	1.0 / 1.75 / 1.75 / 3.3
Optional	Safety device (FFD)
Product Size (mm)	600 (W) x 510 (D) x 110 (H)
Cut-out Size (mm)	560 (W) x 480 (D)
Packing Size (mm)	640 (W) x 540(D) x 150 (H)
Loading (20'/40'/40HQ)	540/1120/1310



MGBG-604CE BL ● / WH ○ / IV ○

Panel	Tempered glass
Panel Support	Enamel Wire
Knob Material	Bakelite
Heat Power(KW)	1.0 / 1.75 / 1.75 / 3.3
Optional	Safety device (FFD)
Product Size (mm)	600 (W) x 510 (D) x 110 (H)
Cut-out Size (mm)	560 (W) x 480 (D)
Packing Size (mm)	640 (W) x 540(D) x 150 (H)
Loading (20'/40'/40HQ)	540/1120/1310

GLASS SERIES (CAST IRON)



MGBG-603M BL ● / WH ○ / IV ○

Panel	Tempered glass
Panel Support	Cast iron
Knob Material	Metal
Heat Power(KW)	1.75 / 2.7 / 3.3
Optional	Safety device (FFD)
Product Size (mm)	600 (W) x 510 (D) x 110 (H)
Cut-out Size (mm)	560 (W) x 480 (D)
Packing Size (mm)	640 (W) x 540(D) x 150 (H)
Loading (20'/40'/40HQ)	540/1120/1310

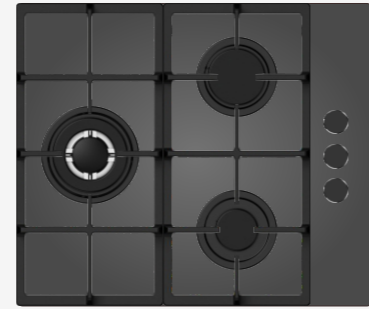

MGBG-603MC BL ● / WH ○ / IV ○

Panel	Tempered glass
Panel Support	Cast iron
Knob Material	Metal
Heat Power(KW)	1.75 / 2.7 / 3.3
Optional	Safety device (FFD)
Product Size (mm)	600 (W) x 510 (D) x 110 (H)
Cut-out Size (mm)	560 (W) x 480 (D)
Packing Size (mm)	640 (W) x 540(D) x 150 (H)
Loading (20'/40'/40HQ)	540/1120/1310

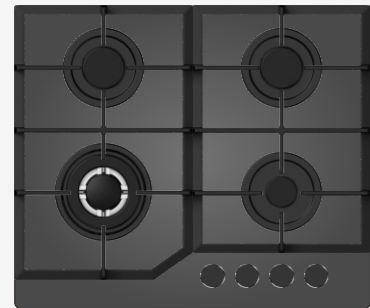

MGBG-604M BL ● / WH ○ / IV ○

Panel	Tempered glass
Panel Support	Cast iron
Knob Material	Metal
Heat Power(KW)	1.0 / 1.75 / 1.75 / 3.3
Optional	Safety device (FFD)
Product Size (mm)	600 (W) x 510 (D) x 110 (H)
Cut-out Size (mm)	560 (W) x 480 (D)
Packing Size (mm)	640 (W) x 540(D) x 150 (H)
Loading (20'/40'/40HQ)	540/1120/1310

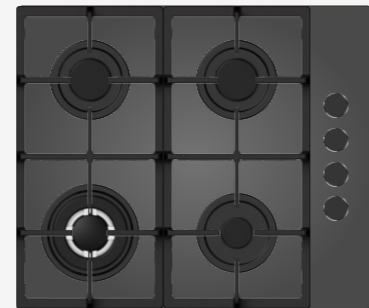

MGBG-604MC BL ● / WH ○ / IV ○

Panel	Tempered glass
Panel Support	Cast iron
Knob Material	Metal
Heat Power(KW)	1.0 / 1.75 / 1.75 / 3.3
Optional	Safety device (FFD)
Product Size (mm)	600 (W) x 510 (D) x 110 (H)
Cut-out Size (mm)	560 (W) x 480 (D)
Packing Size (mm)	640 (W) x 540(D) x 150 (H)
Loading (20'/40'/40HQ)	540/1120/1310

GLASS SERIES (ENAMEL WIRE)



MGBG-603ME BL ● / WH ○ / IV ○

Panel	Tempered glass
Panel Support	Enamel Wire
Knob Material	Bakelite
Heat Power(KW)	1.75 / 2.7 / 3.3
Optional	Safety device (FFD)
Product Size (mm)	600 (W) x 510 (D) x 110 (H)
Cut-out Size (mm)	560 (W) x 480 (D)
Packing Size (mm)	640 (W) x 540(D) x 150 (H)
Loading (20'/40'/40HQ)	540/1120/1310



MGBG-603MCE BL ● / WH ○ / IV ○

Panel	Tempered glass
Panel Support	Enamel Wire
Knob Material	Bakelite
Heat Power(KW)	1.75 / 2.7 / 3.3
Optional	Safety device (FFD)
Product Size (mm)	600 (W) x 510 (D) x 110 (H)
Cut-out Size (mm)	560 (W) x 480 (D)
Packing Size (mm)	640 (W) x 540(D) x 150 (H)
Loading (20'/40'/40HQ)	540/1120/1310



MGBG-604ME BL ● / WH ○ / IV ○

Panel	Tempered glass
Panel Support	Enamel Wire
Knob Material	Bakelite
Heat Power(KW)	1.0 / 1.75 / 1.75 / 3.3
Optional	Safety device (FFD)
Product Size (mm)	600 (W) x 510 (D) x 110 (H)
Cut-out Size (mm)	560 (W) x 480 (D)
Packing Size (mm)	640 (W) x 540(D) x 150 (H)
Loading (20'/40'/40HQ)	540/1120/1310



MGBG-604MCE BL ● / WH ○ / IV ○

Panel	Tempered glass
Panel Support	Enamel Wire
Knob Material	Bakelite
Heat Power(KW)	1.0 / 1.75 / 1.75 / 3.3
Optional	Safety device (FFD)
Product Size (mm)	600 (W) x 510 (D) x 110 (H)
Cut-out Size (mm)	560 (W) x 480 (D)
Packing Size (mm)	640 (W) x 540(D) x 150 (H)
Loading (20'/40'/40HQ)	540/1120/1310

GLASS SERIES (CAST IRON)

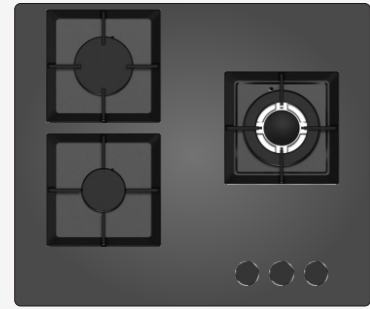

MGBG-603S2 BL ● / WH ○ / IV ○

Panel	Tempered glass
Panel Support	Cast iron
Knob Material	Metal
Heat Power(KW)	1.75 / 2.7 / 3.3
Optional	Safety device (FFD)
Product Size (mm)	600 (W) x 510 (D) x 110 (H)
Cut-out Size (mm)	560 (W) x 480 (D)
Packing Size (mm)	640 (W) x 540(D) x 150 (H)
Loading (20'/40'/40HQ)	540/1120/1310

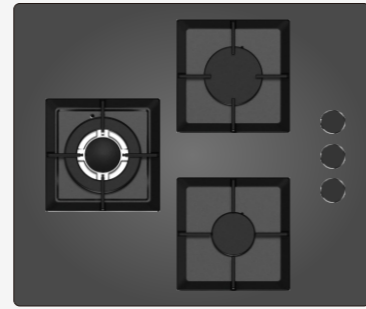

MGBG-603CS2 BL ● / WH ○ / IV ○

Panel	Tempered glass
Panel Support	Cast iron
Knob Material	Metal
Heat Power(KW)	1.75 / 2.7 / 3.3
Optional	Safety device (FFD)
Product Size (mm)	600 (W) x 510 (D) x 110 (H)
Cut-out Size (mm)	560 (W) x 480 (D)
Packing Size (mm)	640 (W) x 540(D) x 150 (H)
Loading (20'/40'/40HQ)	540/1120/1310

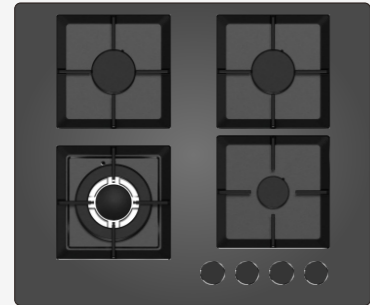

MGBG-604S2 BL ● / WH ○ / IV ○

Panel	Tempered glass
Panel Support	Cast iron
Knob Material	Metal
Heat Power(KW)	1.0 / 1.75 / 1.75 / 3.3
Optional	Safety device (FFD)
Product Size (mm)	600 (W) x 510 (D) x 110 (H)
Cut-out Size (mm)	560 (W) x 480 (D)
Packing Size (mm)	640 (W) x 540(D) x 150 (H)
Loading (20'/40'/40HQ)	540/1120/1310

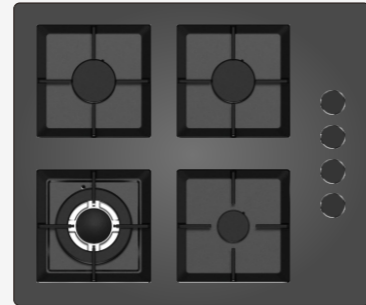

MGBG-604CS2 BL ● / WH ○ / IV ○

Panel	Tempered glass
Panel Support	Cast iron
Knob Material	Metal
Heat Power(KW)	1.0 / 1.75 / 1.75 / 3.3
Optional	Safety device (FFD)
Product Size (mm)	600 (W) x 510 (D) x 110 (H)
Cut-out Size (mm)	560 (W) x 480 (D)
Packing Size (mm)	640 (W) x 540(D) x 150 (H)
Loading (20'/40'/40HQ)	540/1120/1310



GLASS SERIES (ENAMEL WIRE)

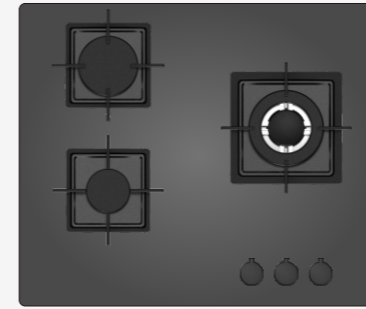

MGBG-603S2E BL ● / WH ○ / IV ○

Panel	Tempered glass
Panel Support	Enamel Wire
Knob Material	Bakelite
Heat Power(KW)	1.75 / 2.7 / 3.3
Optional	Safety device (FFD)
Product Size (mm)	600 (W) x 510 (D) x 110 (H)
Cut-out Size (mm)	560 (W) x 480 (D)
Packing Size (mm)	640 (W) x 540(D) x 150 (H)
Loading (20'/40'/40HQ)	540/1120/1310

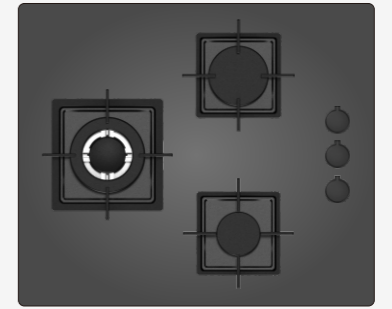

MGBG-603CE BL ● / WH ○ / IV ○

Panel	Tempered glass
Panel Support	Enamel Wire
Knob Material	Bakelite
Heat Power(KW)	1.75 / 2.7 / 3.3
Optional	Safety device (FFD)
Product Size (mm)	600 (W) x 510 (D) x 110 (H)
Cut-out Size (mm)	560 (W) x 480 (D)
Packing Size (mm)	640 (W) x 540(D) x 150 (H)
Loading (20'/40'/40HQ)	540/1120/1310

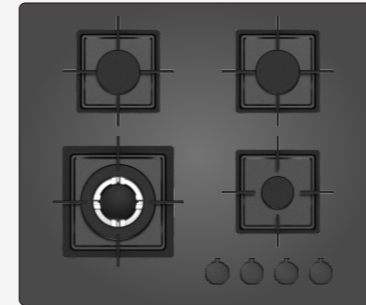

MGBG-604S2E BL ● / WH ○ / IV ○

Panel	Tempered glass
Panel Support	Enamel Wire
Knob Material	Bakelite
Heat Power(KW)	1.0 / 1.75 / 1.75 / 3.3
Optional	Safety device (FFD)
Product Size (mm)	600 (W) x 510 (D) x 110 (H)
Cut-out Size (mm)	560 (W) x 480 (D)
Packing Size (mm)	640 (W) x 540(D) x 150 (H)
Loading (20'/40'/40HQ)	540/1120/1310

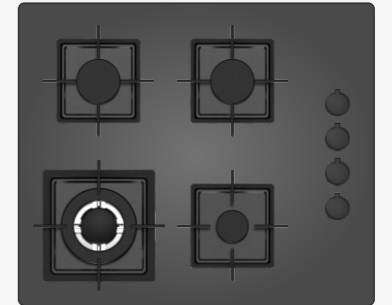

MGBG-604CS2E BL ● / WH ○ / IV ○

Panel	Tempered glass
Panel Support	Enamel Wire
Knob Material	Bakelite
Heat Power(KW)	1.0 / 1.75 / 1.75 / 3.3
Optional	Safety device (FFD)
Product Size (mm)	600 (W) x 510 (D) x 110 (H)
Cut-out Size (mm)	560 (W) x 480 (D)
Packing Size (mm)	640 (W) x 540(D) x 150 (H)
Loading (20'/40'/40HQ)	540/1120/1310

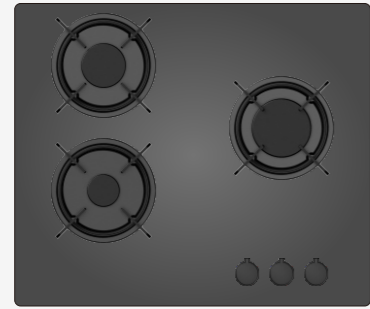

MGBG-603EE BL ● / WH ○ / IV ○

Panel	Tempered glass
Panel Support	Enamel Wire
Knob Material	Bakelite
Heat Power(KW)	1.0 / 1.75 / 2.7
Optional	Safety device (FFD)
Product Size (mm)	600 (W) x 510 (D) x 110 (H)
Cut-out Size (mm)	560 (W) x 480 (D)
Packing Size (mm)	640 (W) x 540(D) x 150 (H)
Loading (20'/40'/40HQ)	540/1120/1310

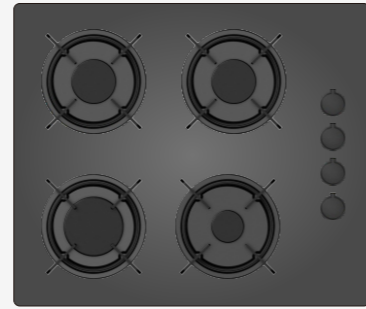

MGBG-604CEE BL ● / WH ○ / IV ○

Panel	Tempered glass
Panel Support	Enamel Wire
Knob Material	Bakelite
Heat Power(KW)	1.0 / 1.75 / 1.75 / 2.7
Optional	Safety device (FFD)
Product Size (mm)	600 (W) x 510 (D) x 110 (H)
Cut-out Size (mm)	560 (W) x 480 (D)
Packing Size (mm)	640 (W) x 540(D) x 150 (H)
Loading (20'/40'/40HQ)	540/1120/1310

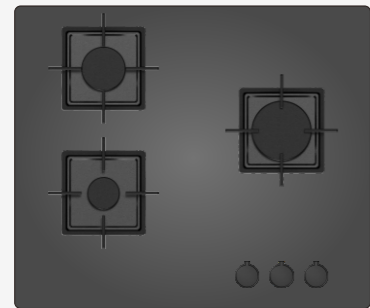

MGBG-603S2EE BL ● / WH ○ / IV ○

Panel	Tempered glass
Panel Support	Enamel Wire
Knob Material	Bakelite
Heat Power(KW)	1.0 / 1.75 / 2.7
Optional	Safety device (FFD)
Product Size (mm)	600 (W) x 510 (D) x 110 (H)
Cut-out Size (mm)	560 (W) x 480 (D)
Packing Size (mm)	640 (W) x 540(D) x 150 (H)
Loading (20'/40'/40HQ)	540/1120/1310

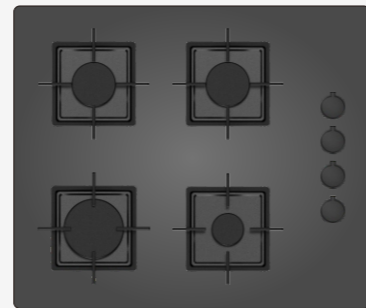

MGBG-604S2CEE BL ● / WH ○ / IV ○

Panel	Tempered glass
Panel Support	Enamel Wire
Knob Material	Bakelite
Heat Power(KW)	1.0 / 1.75 / 1.75 / 2.7
Optional	Safety device (FFD)
Product Size (mm)	600 (W) x 510 (D) x 110 (H)
Cut-out Size (mm)	560 (W) x 480 (D)
Packing Size (mm)	640 (W) x 540(D) x 150 (H)
Loading (20'/40'/40HQ)	540/1120/1310



MGBG-603MEE BL ● / WH ○ / IV ○

Panel	Tempered glass
Panel Support	Enamel Wire
Knob Material	Bakelite
Heat Power(KW)	1.0 / 1.75 / 2.7
Optional	Safety device (FFD)
Product Size (mm)	600 (W) x 510 (D) x 110 (H)
Cut-out Size (mm)	560 (W) x 480 (D)
Packing Size (mm)	640 (W) x 540(D) x 150 (H)
Loading (20'/40'/40HQ)	540/1120/1310



MGBG-604MCEE BL ● / WH ○ / IV ○

Panel	Tempered glass
Panel Support	Enamel Wire
Knob Material	Bakelite
Heat Power(KW)	1.0 / 1.75 / 2.7 / 2.7
Optional	Safety device (FFD)
Product Size (mm)	600 (W) x 510 (D) x 110 (H)
Cut-out Size (mm)	560 (W) x 480 (D)
Packing Size (mm)	640 (W) x 540(D) x 150 (H)
Loading (20'/40'/40HQ)	540/1120/1310

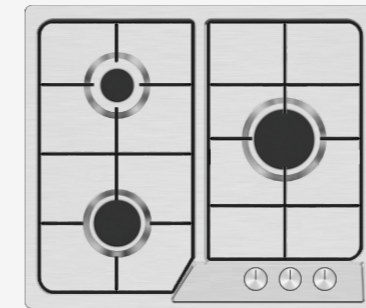

MGBS-603EE SS ○ / BL ●

Panel	Stainless steel
Panel Support	Enamel Wire
Knob Material	Bakelite
Heat Power(KW)	1.0 / 2.7 / 2.7
Optional	Safety device (FFD)
Product Size (mm)	585 (W) x 505 (D) x 95 (H)
Cut-out Size (mm)	560 (W) x 480 (D)
Packing Size (mm)	640 (W) x 540(D) x 150 (H)
Loading (20'/40'/40HQ)	540/1120/1310

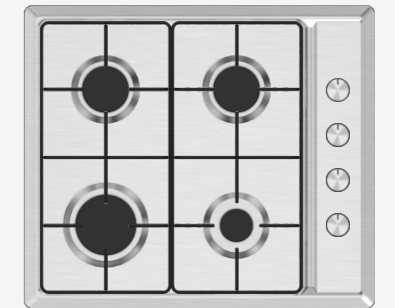

MGBS-604CEE SS ○ / BL ●

Panel	Stainless steel
Panel Support	Enamel Wire
Knob Material	Bakelite
Heat Power(KW)	1.0 / 1.75 / 1.75 / 2.7
Optional	Safety device (FFD)
Product Size (mm)	585 (W) x 505 (D) x 95 (H)
Cut-out Size (mm)	560 (W) x 480 (D)
Packing Size (mm)	640 (W) x 540(D) x 150 (H)
Loading (20'/40'/40HQ)	540/1120/1310

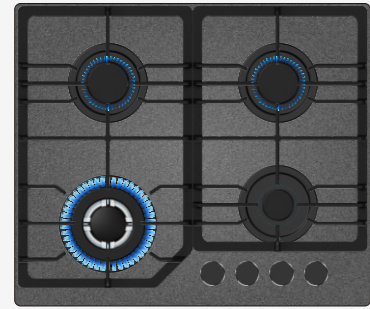

MGBG-604TS BL ● / WH ○ / IV ○

Panel	Mat glass
Panel Support	Cast iron
Knob Material	Metal
Heat Power(KW)	1.0 / 1.75 / 1.75 / 3.3
Safety device (FFD)	Yes
Product Size (mm)	600 (W) x 510 (D) x 110 (H)
Cut-out Size (mm)	560 (W) x 480 (D)
Packing Size (mm)	640 (W) x 540(D) x 150 (H)
Loading (20'/40'/40HQ)	540/1120/1310

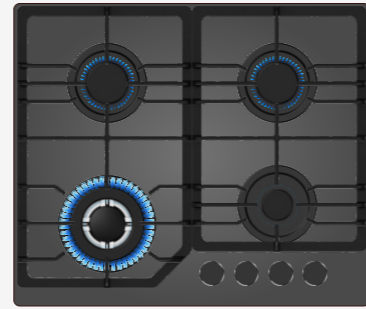

MGBG-604TB BL ● / WH ○ / IV ○

Panel	Black Tempered glass
Panel Support	Cast iron
Knob Material	Metal
Heat Power(KW)	1.0 / 1.75 / 1.75 / 3.3
Safety device (FFD)	Yes
Product Size (mm)	600 (W) x 510 (D) x 110 (H)
Cut-out Size (mm)	560 (W) x 480 (D)
Packing Size (mm)	640 (W) x 540(D) x 150 (H)
Loading (20'/40'/40HQ)	540/1120/1310

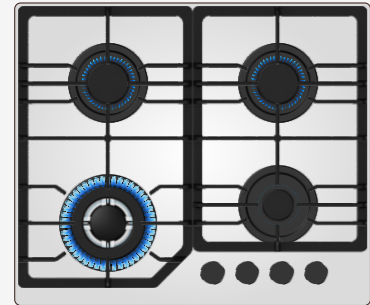

MGBG-604TW BL ● / WH ○ / IV ○

Panel	White Tempered glass
Panel Support	Cast iron
Knob Material	Metal
Heat Power(KW)	1.0 / 1.75 / 1.75 / 3.3
Safety device (FFD)	Yes
Product Size (mm)	600 (W) x 510 (D) x 110 (H)
Cut-out Size (mm)	560 (W) x 480 (D)
Packing Size (mm)	640 (W) x 540(D) x 150 (H)
Loading (20'/40'/40HQ)	540/1120/1310

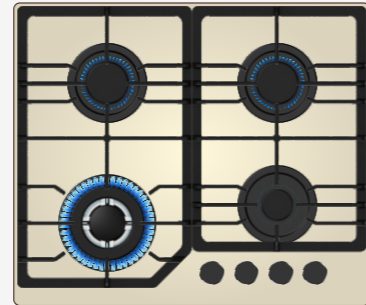

MGBG-604TI BL ● / WH ○ / IV ○

Panel	Ivory Tempered glass
Panel Support	Cast iron
Knob Material	Metal
Heat Power(KW)	1.0 / 1.75 / 1.75 / 3.3
Safety device (FFD)	Yes
Product Size (mm)	600 (W) x 510 (D) x 110 (H)
Cut-out Size (mm)	560 (W) x 480 (D)
Packing Size (mm)	640 (W) x 540(D) x 150 (H)
Loading (20'/40'/40HQ)	540/1120/1310

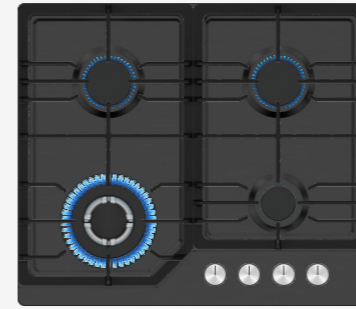

MGBS-604TN SS ○ / BL ●

Panel	Black Nano-Painting
Panel Support	Cast iron
Knob Material	Metal
Heat Power(KW)	1.0 / 1.75 / 1.75 / 3.3
Safety device (FFD)	Safety device (FFD)
Product Size (mm)	585 (W) x 505 (D) x 95 (H)
Cut-out Size (mm)	560 (W) x 480 (D)
Packing Size (mm)	640 (W) x 540(D) x 150 (H)
Loading (20'/40'/40HQ)	540/1120/1310

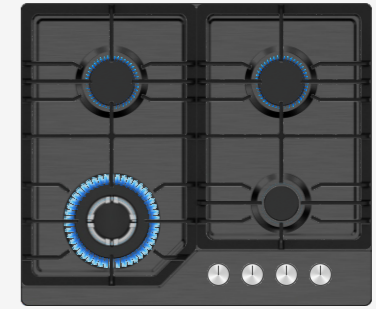

MGBS-604TE SS ○ / BL ●

Panel	Black Enamelled
Panel Support	Cast iron
Knob Material	Metal
Heat Power(KW)	1.0 / 1.75 / 1.75 / 3.3
Safety device (FFD)	Safety device (FFD)
Product Size (mm)	585 (W) x 505 (D) x 95 (H)
Cut-out Size (mm)	560 (W) x 480 (D)
Packing Size (mm)	640 (W) x 540(D) x 150 (H)
Loading (20'/40'/40HQ)	540/1120/1310

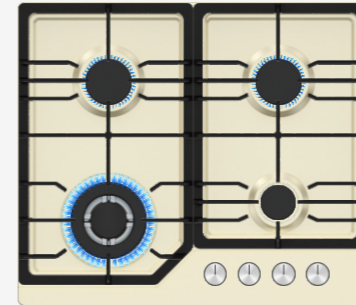

MGBS-604TI SS ○ / BL ●

Panel	Ivory Enamelled
Panel Support	Cast iron
Knob Material	Metal
Heat Power(KW)	1.0 / 1.75 / 1.75 / 3.3
Safety device (FFD)	Yes
Product Size (mm)	585 (W) x 505 (D) x 95 (H)
Cut-out Size (mm)	560 (W) x 480 (D)
Packing Size (mm)	640 (W) x 540(D) x 150 (H)
Loading (20'/40'/40HQ)	540/1120/1310

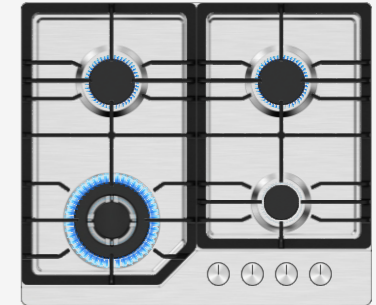

MGBS-604T SS ○ / BL ●

Panel	Stainless steel
Panel Support	Cast iron
Knob Material	Metal
Heat Power(KW)	1.0 / 1.75 / 1.75 / 3.3
Safety device (FFD)	Yes
Product Size (mm)	585 (W) x 505 (D) x 95 (H)
Cut-out Size (mm)	560 (W) x 480 (D)
Packing Size (mm)	640 (W) x 540(D) x 150 (H)
Loading (20'/40'/40HQ)	540/1120/1310

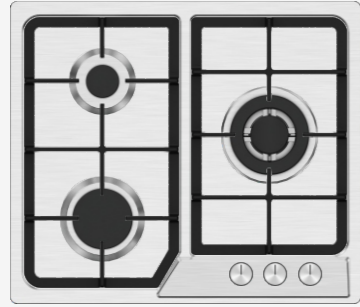

MGBS-603

SS ● / BL ●

Panel	Stainless steel
Panel Support	Cast iron
Knob Material	Metal
Heat Power(KW)	1.0 / 2.7 / 3.3
Optional	Safety device (FFD)
Product Size (mm)	585 (W) x 505 (D) x 95 (H)
Cut-out Size (mm)	560 (W) x 480 (D)
Packing Size (mm)	640 (W) x 540(D) x 150 (H)
Loading (20'/40'/40HQ)	540/1120/1310

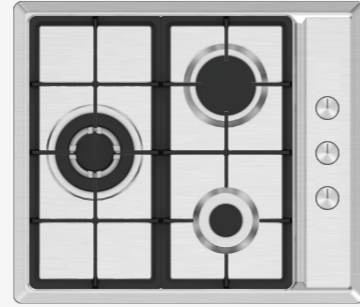

MGBS-603C

SS ● / BL ●

Panel	Stainless steel
Panel Support	Cast iron
Knob Material	Metal
Heat Power(KW)	1.0 / 2.7 / 3.3
Optional	Safety device (FFD)
Product Size (mm)	585 (W) x 505 (D) x 95 (H)
Cut-out Size (mm)	560 (W) x 480 (D)
Packing Size (mm)	640 (W) x 540(D) x 150 (H)
Loading (20'/40'/40HQ)	540/1120/1310



MGBS-604

SS ● / BL ●

Panel	Stainless steel
Panel Support	Cast iron
Knob Material	Metal
Heat Power(KW)	1.0 / 1.75 / 1.75 / 3.3
Optional	Safety device (FFD)
Product Size (mm)	585 (W) x 505 (D) x 95 (H)
Cut-out Size (mm)	560 (W) x 480 (D)
Packing Size (mm)	640 (W) x 540(D) x 150 (H)
Loading (20'/40'/40HQ)	540/1120/1310

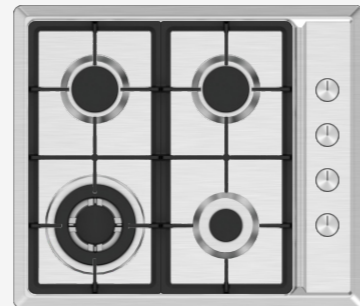

MGBS-604C

SS ● / BL ●

Panel	Stainless steel
Panel Support	Cast iron
Knob Material	Metal
Heat Power(KW)	1.0 / 1.75 / 1.75 / 3.3
Optional	Safety device (FFD)
Product Size (mm)	585 (W) x 505 (D) x 95 (H)
Cut-out Size (mm)	560 (W) x 480 (D)
Packing Size (mm)	640 (W) x 540(D) x 150 (H)
Loading (20'/40'/40HQ)	540/1120/1310

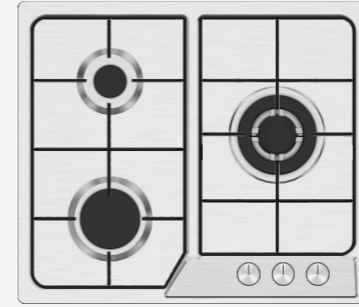

MGBS-603E

SS ● / BL ●

Panel	Stainless steel
Panel Support	Enamel Wire
Knob Material	Bakelite
Heat Power(KW)	1.0 / 2.7 / 3.3
Optional	Safety device (FFD)
Product Size (mm)	585 (W) x 505 (D) x 95 (H)
Cut-out Size (mm)	560 (W) x 480 (D)
Packing Size (mm)	640 (W) x 540(D) x 150 (H)
Loading (20'/40'/40HQ)	540/1120/1310

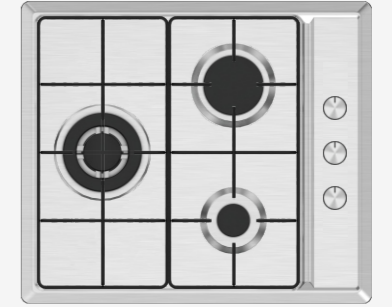

MGBS-603CE

SS ● / BL ●

Panel	Stainless steel
Panel Support	Enamel Wire
Knob Material	Bakelite
Heat Power(KW)	1.0 / 2.7 / 3.3
Optional	Safety device (FFD)
Product Size (mm)	585 (W) x 505 (D) x 95 (H)
Cut-out Size (mm)	560 (W) x 480 (D)
Packing Size (mm)	640 (W) x 540(D) x 150 (H)
Loading (20'/40'/40HQ)	540/1120/1310



MGBS-604E

SS ● / BL ●

Panel	Stainless steel
Panel Support	Enamel Wire
Knob Material	Bakelite
Heat Power(KW)	1.0 / 1.75 / 1.75 / 3.3
Optional	Safety device (FFD)
Product Size (mm)	585 (W) x 505 (D) x 95 (H)
Cut-out Size (mm)	560 (W) x 480 (D)
Packing Size (mm)	640 (W) x 540(D) x 150 (H)
Loading (20'/40'/40HQ)	540/1120/1310

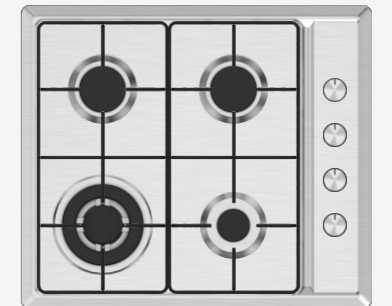

MGBS-604CE

SS ● / BL ●

Panel	Stainless steel
Panel Support	Enamel Wire
Knob Material	Bakelite
Heat Power(KW)	1.0 / 1.75 / 1.75 / 3.3
Optional	Safety device (FFD)
Product Size (mm)	585 (W) x 505 (D) x 95 (H)
Cut-out Size (mm)	560 (W) x 480 (D)
Packing Size (mm)	640 (W) x 540(D) x 150 (H)
Loading (20'/40'/40HQ)	540/1120/1310



Hammer Series

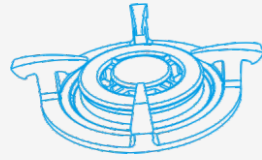

Crown Series

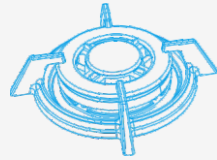

Diamond Series

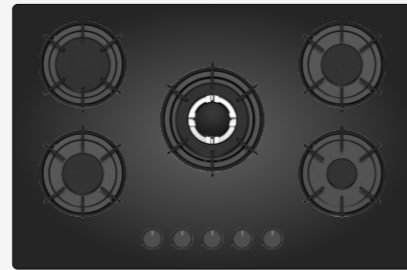
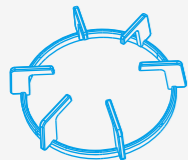

Classic Series

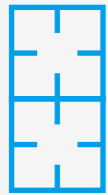

Snowflake Series



Football Field Series

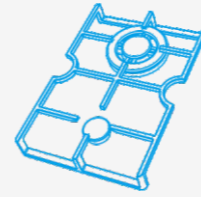

Small Waist Series



Take Off Series



Tangram Series



Hourglass Series





TGW(B)2-P

- Color: Black / White
- Certificate: CE
- 2 Burner Gas Grill: 2x1.8Kw
- With backguard
- Iron Grids: Electrophores
- Enamel cap + Aluminium seat (White)
- Manual ignition
- Product Size: 590mm×280mm×80mm
- Packing Size: 595mm×380mm×75mm
- N.W.(kg): 2.37
- Loading (20GP/40GP/40HQ): 1750/3600/4100



TGB(W)2-C

- Color: Black / White
- Certificate: CE
- 2 Burner Gas Grill: 2x1.8Kw
- With Cover
- Iron Grids: Electrophores
- Enamel cap + Aluminium seat (Black)
- Manual ignition
- Product Size: 590mm×320mm×80mm
- Packing Size: 595mm×380mm×72mm
- N.W.(kg): 2.67
- Loading (20GP/40GP/40HQ): 1800/3600/4200

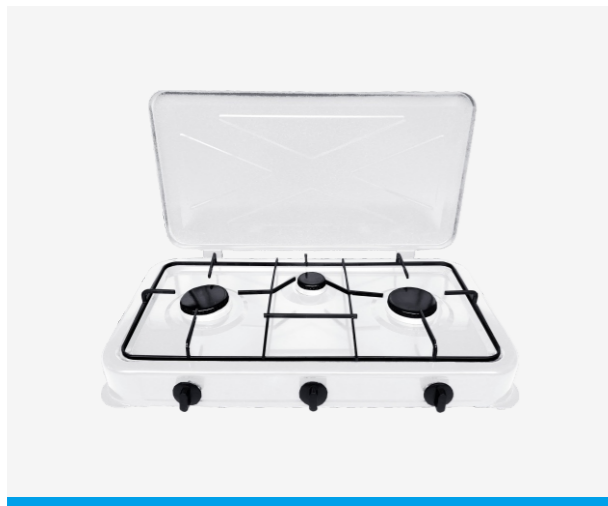

TGB(W)4-PS

- Color: Black / White
- Certificate: CE
- 3 Burner Gas Stove: 3x1.8Kw
- With backguard
- Iron Grids: Electrophores
- Enamel cap + Aluminium seat (Black)
- Manual ignition
- Product Size: 490mm×540mm×140mm
- Packing Size: 495mm×545mm×155mm
- N.W.(kg): 4.54
- Loading (20GP/40GP/40HQ): 700/1400/1650



SG-203-16(2 Burners)

- Item Dimensions LxWxH: 560 x 320x 95mm
- Certificate: CE
- Power: 15000BTU x 2
- Input Pressure: 1bar/100kpa Pipe Valve KR-276Y15
- Ignition Device: 1 piezoelectric ignition system
- Loading (20'/40'/40HQ): 1400/2900/3100
- G.W. / N.W.: 4kg / 3.6kg
- Quantity: 4 pieces/master box



SG-208-79G29(2 Burners)

- Item Dimensions LxWxH: 420 x 230x 83mm
- Certificate: CE
- Power: 7000BTU x 2 (7.4MJ/h x 2, 2kW x 2, 150g/h x 2)
- Input Pressure: 1bar/100kpa Pipe Valve KR-276Y15
- Loading (20'/40'/40HQ): 2460/5010/6270
- G.W. / N.W.: 1.5kg / 1.3kg
- Quantity: 5 pieces/master box
- Accessories: valve body, 1 meter long pipe



BBQ-139(3 Burners)

- Item Dimensions LxWxH: 625 x 380x 290mm
- Certificate: CE
- Power: Two 7000BTU mushroom burners upwards,
One 7000BTU middle burner downwards.
- Input Pressure: 1bar/100kpa Pipe Valve KR-276Y15
- Ignition Device: 2 piezoelectric ignition system
- Loading (20'/40'): 1250 / 2950
- G.W. / N.W.: 5.0kg / 4.5kg
- Quantity: 3 pieces/master box
- Accessories: valve body, 1 meter long pipe



MCHS-6021RT

SS ○ / BL ● / WH ○

Width	600mm
Material	Painted body or S/S body
Airflow	400m ³ /h
Motor Type	1x100W
Control Type	Piano switch control
Level of Speed	3 speeds
Lighting	1x2W LED Lamp
Filter Type	3 Layer aluminium grease fliter Activated carbon fliter
Air Outlet	120mm
Packing size	633x522x132mm (600mm)
Loading QTY(20/40/40HQ)	640 / 1320 / 1550 (600mm)



MCHS-6021CS

SS ○ / BL ● / WH ○

Width	600mm
Material	Painted body or S/S body
Airflow	400m ³ /h
Motor Type	1x100W
Control Type	Touch control
Level of Speed	3 speeds
Lighting	1x2W LED Lamp
Filter Type	3 Layer aluminium grease fliter Activated carbon fliter
Air Outlet	120mm
Packing size	633x522x132mm (600mm)
Loading QTY(20/40/40HQ)	640 / 1320 / 1550 (600mm)

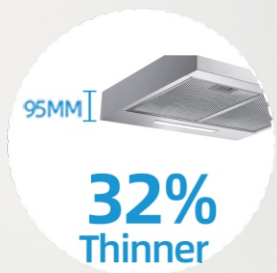

32% Thinner

Larger Loading Quantity 1500+/40HQ



162% Stronger

400CBM/H Air Volume



3 Exhaust Fan Speeds

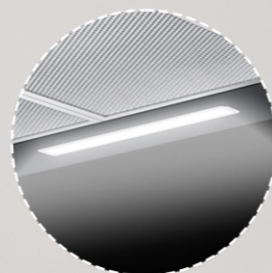

LED Strip

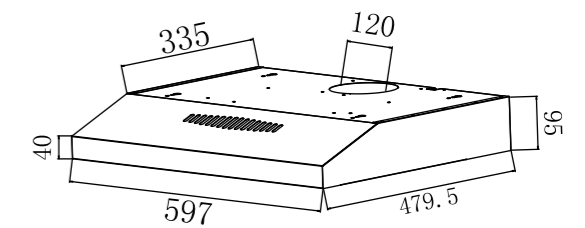
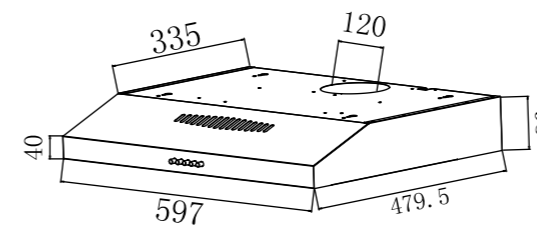



MCHS-6003SL SS  / BL  / WH 

MCHS-6003SEL SS  / BL  / WH 

Width 600mm
Material Painted body or S/S body
Airflow 400m³/h
Motor Type 1x100W
Control Type Mechanical Rocker Control
Level of Speed 2 speeds
Lighting 2x1.5W LED Lamp
Filter Type 3 Layer aluminium grease fliter
 Activated carbon fliter
Air Outlet 150mm
Packing size 650x260x358mm (600mm)
Loading QTY(20/40/40HQ) 530 / 1100 / 1270 (600mm)

Width 600mm
Material Painted body or S/S body
Airflow 400m³/h
Motor Type 1x100W
Control Type Touch control
Level of Speed 2 speeds
Lighting 2x1.5W LED Lamp
Filter Type 3 Layer aluminium grease fliter
 Activated carbon fliter
Air Outlet 150mm
Packing size 650x260x358mm (600mm)
Loading QTY(20/40/40HQ) 530 / 1100 / 1270 (600mm)

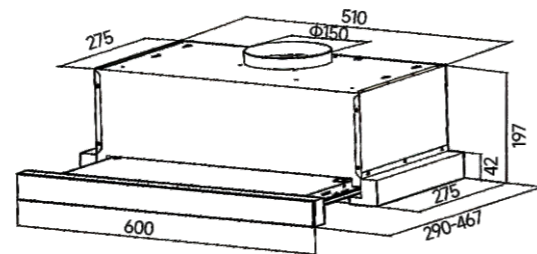
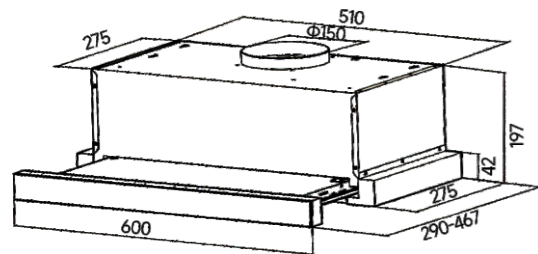

MCHW-H602 SS  / BL  / WH 

MCHW-H603 SS  / BL  / WH 

Width 600/mm
Material Black painted body,
 Black tempered glass
Airflow 720m³/h
Motor Type 1x180W
Control Type Touch control
 Gesture control sensor
Level of Speed 3 speeds
Lighting 2x1.5W LED Lamp
Filter Type 5 Layer aluminium grease fliter
 Activated carbon fliter
Air Outlet 150mm
Packing size 655x455x518mm (600mm)
Loading QTY(20/40/40HQ) 240 / 370 / 430 (600mm)

Width 600mm
Material Painted body or S/S body
Airflow 720m³/h
Motor Type 1 x 180W
Control Type Piano switch control
Level of Speed 3 speeds
Lighting 2x1.5W LED Lamp
Filter Type 3 Layer aluminium grease fliter
 Activated carbon fliter
Air Outlet 150mm
Packing size 641x465x521mm (600mm)
Loading QTY(20/40/40HQ) 240 / 370 / 430 (600mm)

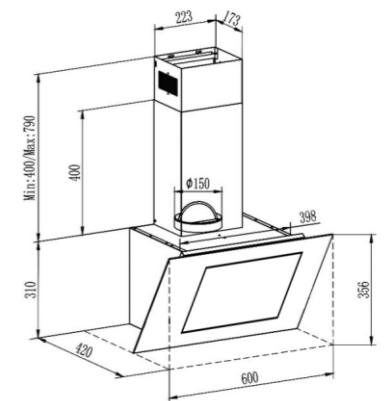
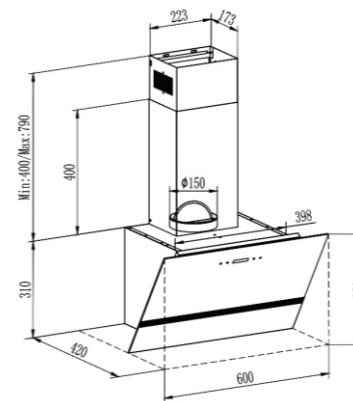

Range Hood Panel Option

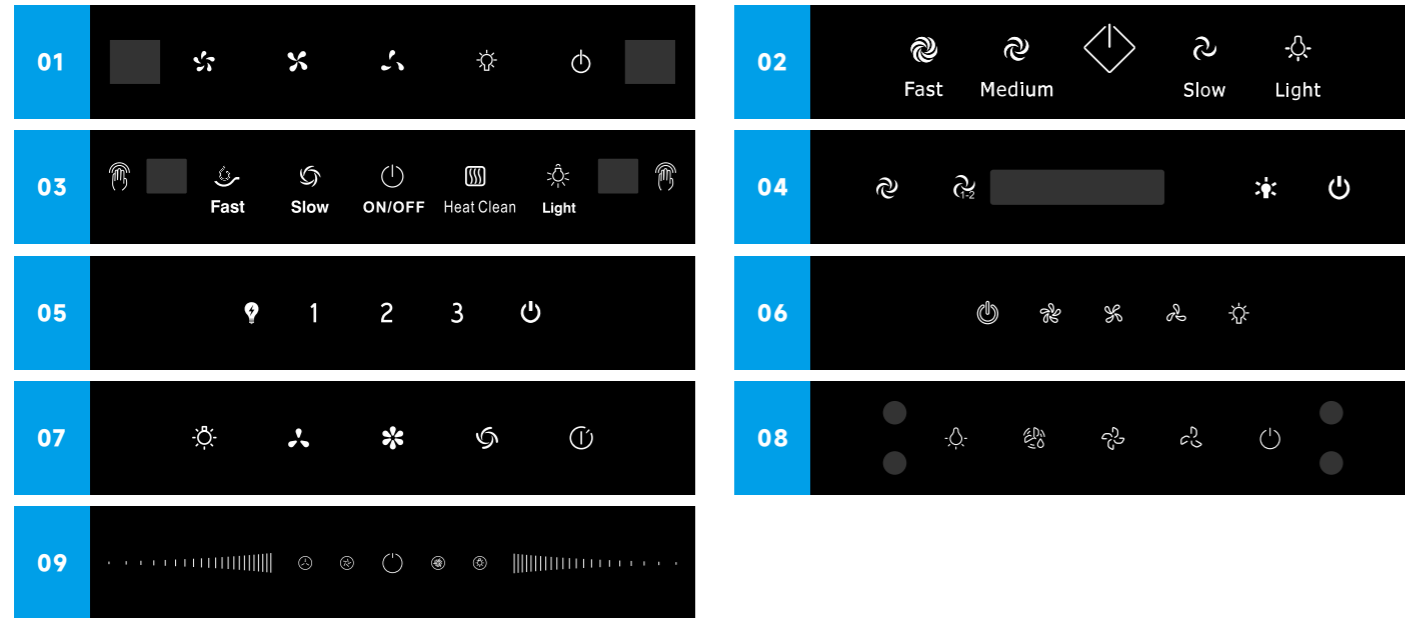

Slim Range Hood

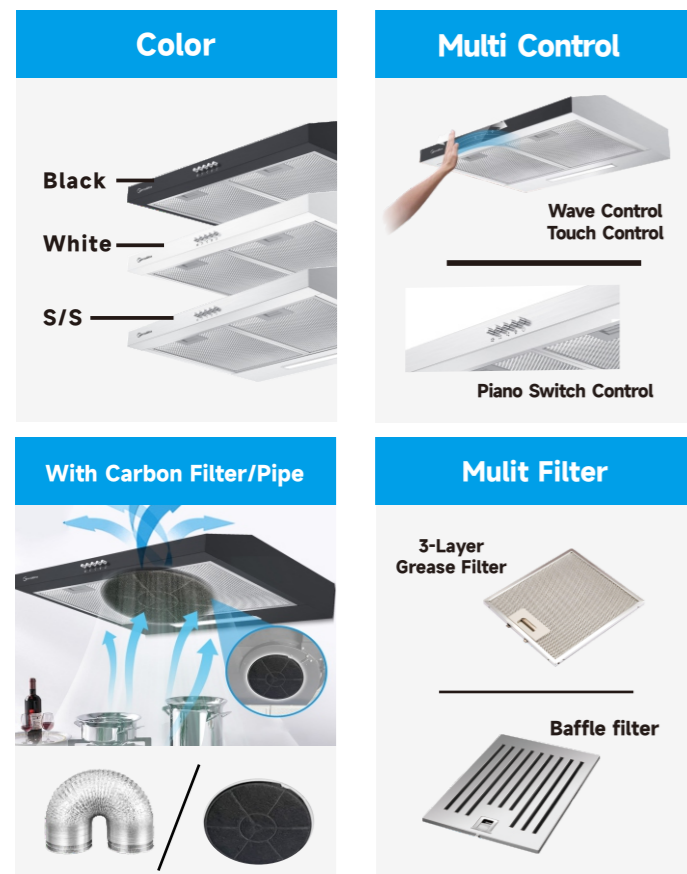

Telescopic Range Hood

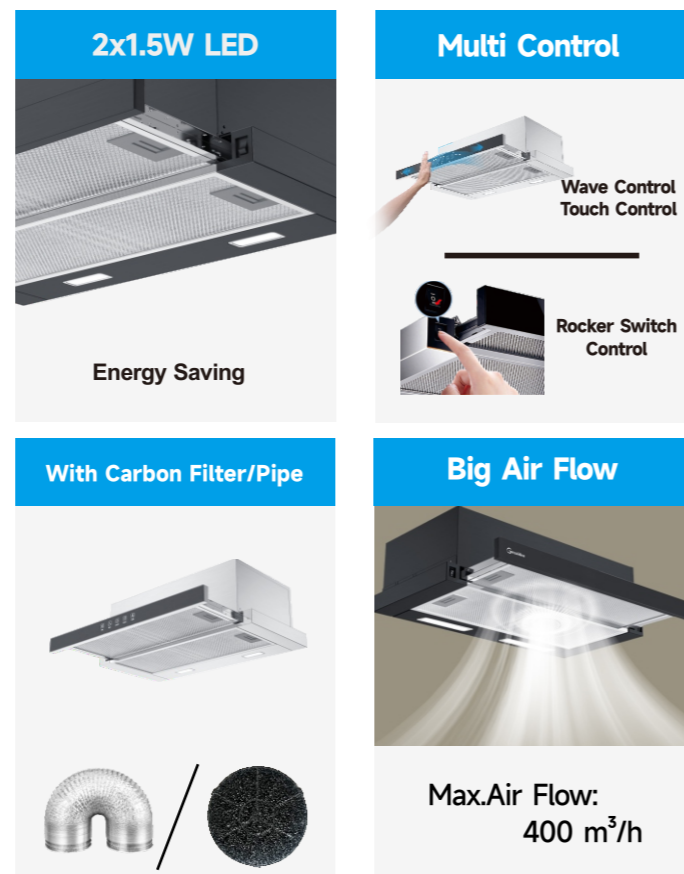

Built-in Multi-Burner Gas Hob Key Parts Option



Built-in Multi-Burner Gas Hob Panel Option

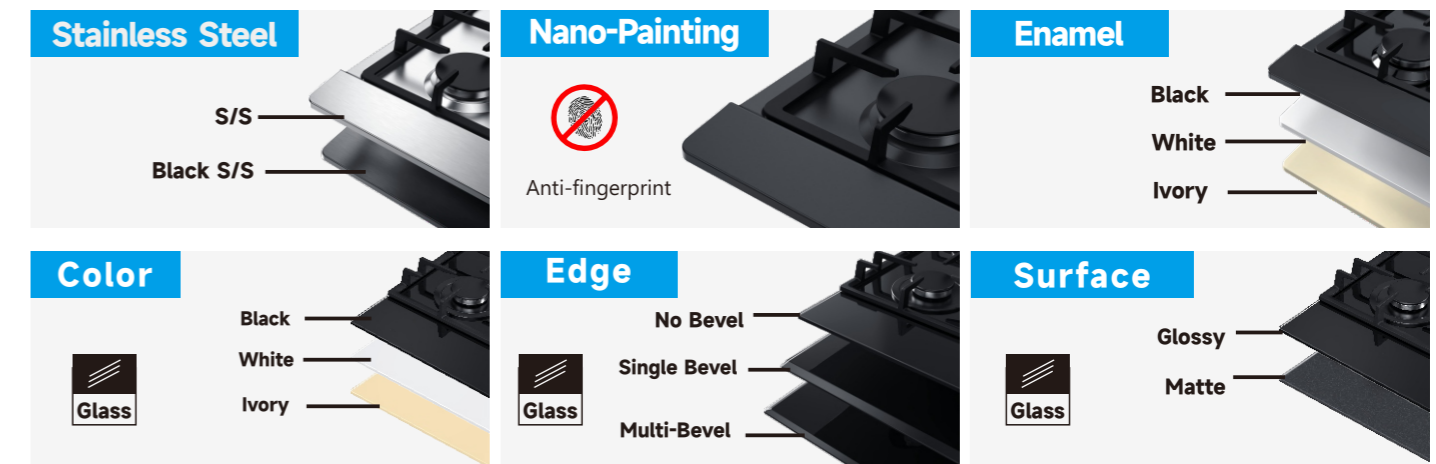

Built-in Multi-Burner Gas Hob Knob Option





EU Low NO_x GAS WATER HEATER

Since Sept. 26, 2018, all gas heaters placed on the European market for the first time must have emissions below 56 mg/kWh. This new generation of Low NO_x heaters achieves a level well below what is established by the regulations.



JSD22-M1LP
JSD22-M1GN

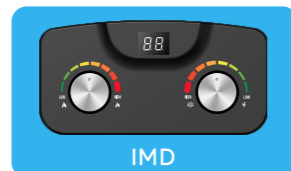

IMD



JSD22-D3LP
JSD22-D3GN

- With ERP certificate: **A**
- Atmospheric gas water heater of 11L/min
- Low NO_x emissions
- Ignition by batteries. Automatic flammulation
- Available for natural gas, propane and butane
- No pilot light: more gas savings
- Variable and modulating power
- White LED digital display

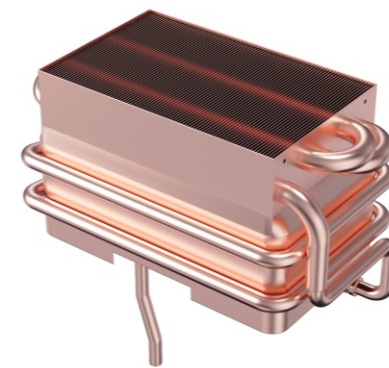

Oxygen-free Copper Heat Exchanger

The oxidation treatment of the oxygen-free copper heat exchanger can prevent the heat exchanger from oxidation or corrosion in the course of use, and has high thermal conductivity and long service life.

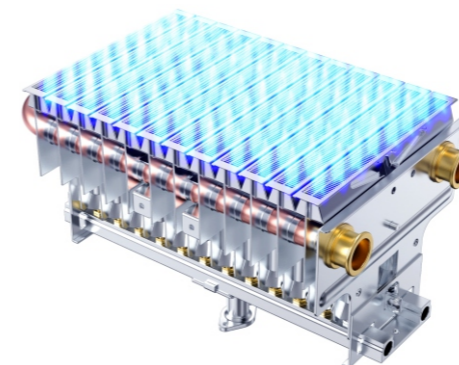

Cooled Burner (Cool System)

Exclusive cooled burner, specifically designed and built to be able to cool the flame base throughout its entire path, thus drastically reducing NO_x emissions into the atmosphere, maximizing its performance.

Patent No. CN 107787429 A



JSD22-D2LP
JSD22-D2GN



JSD22-D1LP
JSD22-D1GN



JSD22-D5LP
JSD22-D5GN



JSD22-D4LP
JSD22-D4GN



JSD22-B1LP
JSD22-B1GN



JSD22-B2LP
JSD22-B2GN

MODELS-11L	JSD22-B1	JSD22-B2	JSD22-D1	JSD22-D2
	JSD22-D3	JSD22-M1	JSD22-M2	JSD22-M3
Gas categories	LPG		GN	
Nominal heat flow rate(Max/Min,kw)	22/8.5		22/8.5	
Gas type	G30/G31		G20/G25	
Gas pressure (mbar)	29/37		20/25	
Hot water capacity ($\Delta t=25^{\circ}$ C,L/min)	11		11	
Net weight (kg)	11		10	
Power supply	Batteries(DC 3V)		Batteries(DC 3V)	
Product Dimension	610x340x180 MM		550x340x180 MM	
Packing Dimension	395x235x710 MM		705x395x235 MM	
Loading Quantity (20GP/40GP/40HQ)	420/870/1020		420/870/1020	