

On-time Delivery

- 1,100,000 units
(annual production capacity)

Continuous Innovation

- Over 20 professional engineers
- Over 3% continuous investment per year

Reliable Quality

- 7 Inspection positions
- National standard testing lab

Professional Logistics

- Export to over 49 countries
- 500 containers delivery per year



Greaidea Gas and Electrical Appliances Co.,Ltd

Address: No.1 Weihua Road, Gaoli New High Tech Industry Zone,
Ronggui Town, Shunde District, Foshan, Guangdong, China

Web: www.greaidea.com / www.cehob.com

Email: info@greaidea.com / sales@greaidea.com



Russia

Kitchen & Bathroom Product Catalog

25+ Years Experience
Your First Choice

About Us

Over 20 Years Of OEM & ODM Experience In Gas Hob, Range Hood and Gas Water Heater

- OEM & ODM gas hob, gas water heater and range hood since 2000.
- Established in 2000, the past over 20 years witnessed great chances of our product, R&D, quality level, and service as well. From now on, Greaidea has its own two production bases with over 500 employees, covering 100,000m². In order to meet the growing marketing needs, we have equipped with 10 assembly lines for gas hob and range hood, 5 assembly lines for gas water heater.

20⁺Y
Since 2000

2
Production bases

500+
Staffs

100,000m²
Area

15
Assembly lines

Kitchen Appliance Division

Greaidea has over 20 year's experience in manufacturing high quality gas hob and range hood. Our factory locates in Ronggui town, Shunde city. In our R&D department, 16 engineers are employed to guarantee our R&D advantage and continuous improvement. Every year, 3% of revenue will be invested to R&D . With excellent manufacturing team & QC team, we can realize the annual output 800,000pcs gas hob and 300,000pcs range hood product with optimal quality.

Gas hob : 800,000 pcs / year
Range hood : 300,000 pcs / year



Final Assembly Line



▶ Online Key Position : 7 Times Inspection



Strict QC System

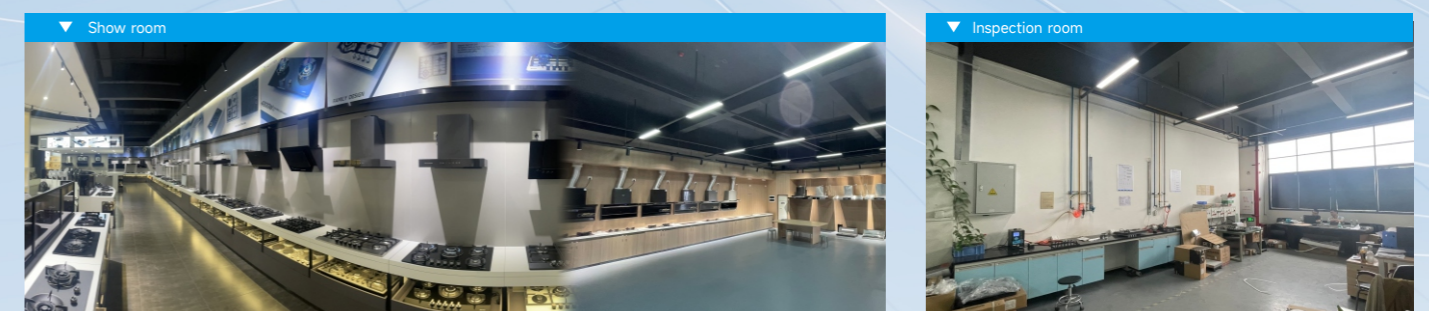
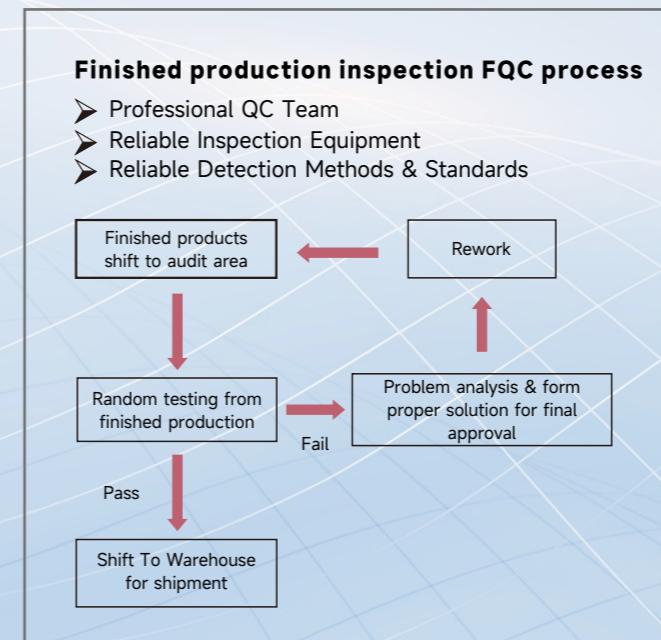
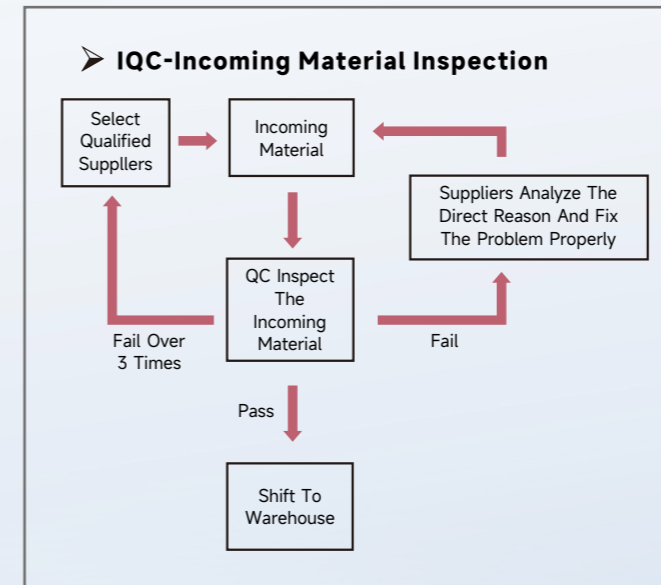



• **MGBG-312T**



BL / WH / IV
● ○ ●

Panel	Tempered glass
Pan support	Cast iron
Knob material	Metal
Heat Power(kW)	1.0 / 3.3
Optional	Safety device (FFD)
Product Size (mm)	310 (W) x 515 (D) x 105 (H)
Cut-out Size (mm)	265 (W) x 475 (D)
Packing Size (mm)	550 (W) x 350(D) x 153 (H)
Loading (20'/40'/40HQ)	990 / 1810 / 2040



• **MGBG-604T**



BL / WH / IV
● ○ ●

Panel	Tempered glass
Pan support	Cast iron
Knob material	Metal
Heat Power(kW)	1.0 / 1.75 / 1.75 / 3.3
Optional	Safety device (FFD)
Product Size (mm)	600 (W) x 510 (D) x 105 (H)
Cut-out Size (mm)	560 (W) x 480 (D)
Packing Size (mm)	646 (W) x 560 (D) x 155 (H)
Loading (20'/40'/40HQ)	540 / 1080 / 1200



• **MGBG-775T**



BL / WH / IV
● ○ ●

Panel	Tempered glass
Pan support	Cast iron
Knob material	Metal
Heat Power(kW)	1.0 / 1.75 / 1.75 / 2.7 / 3.3
Optional	Safety device (FFD)
Product Size (mm)	770 (W) x 510 (D) x 105 (H)
Cut-out Size (mm)	560 (W) x 480 (D)
Packing Size (mm)	816 (W) x 556(D) x 155 (H)
Loading (20'/40'/40HQ)	420 / 870 / 1020



• **MGBS-312T**



SS / BL NP
● ●

Panel	Stainless steel
Pan support	Cast iron
Knob material	Metal
Heat Power(kW)	1.0 / 3.3
Optional	Safety device (FFD)
Product Size (mm)	310 (W) x 510 (D) x 95 (H)
Cut-out Size (mm)	265 (W) x 475 (D)
Packing Size (mm)	550 (W) x 360 (D) x 153 (H)
Loading (20'/40'/40HQ)	990/1810/2040



• **MGBS-604T**



SS / BL NP
● ●

Panel	Stainless steel
Pan support	Cast iron
Knob material	Metal
Heat Power(kW)	1.0 / 1.75 / 1.75 / 3.3
Optional	Safety device (FFD)
Product Size (mm)	585 (W) x 505 (D) x 95 (H)
Cut-out Size (mm)	560 (W) x 480 (D)
Packing Size (mm)	640 (W) x 540(D) x 150 (H)
Loading (20'/40'/40HQ)	540/1120/1310



• **MGBS-765T**



SS / BL NP
● ●

Panel	Stainless steel
Pan support	Cast iron
Knob material	Metal
Heat Power(kW)	1.0 / 1.75 / 1.75 / 2.7 / 3.3
Optional	Safety device (FFD)
Product Size (mm)	760 (W) x 510 (D) x 97(H)
Cut-out Size (mm)	730 (W) x 480 (D)
Packing Size (mm)	820 (W) x 540(D) x 150 (H)
Loading (20'/40'/40HQ)	420 / 870 / 1020



• **MGBG-312C**



BL / WH / IV
● ○ ●

Panel	Tempered glass
Pan support	Cast iron
Knob material	Metal
Heat Power(kW)	1.0 / 3.3
Optional	Safety device (FFD)
Product Size (mm)	310 (W) x 515 (D) x 105 (H)
Cut-out Size (mm)	265 (W) x 475 (D)
Packing Size (mm)	550 (W) x 350(D) x 153 (H)
Loading (20'/40'/40HQ)	990 / 1810 / 2040



• **MGBS-312TB**



SS / BL NP
● ●

Panel	Black Nano-Painting
Pan support	Cast iron
Knob material	Metal
Heat Power(kW)	1.0 / 3.3
Optional	Safety device (FFD)
Product Size (mm)	310 (W) x 510 (D) x 95 (H)
Cut-out Size (mm)	265 (W) x 475 (D)
Packing Size (mm)	550 (W) x 360 (D) x 153 (H)
Loading (20'/40'/40HQ)	990/1810/2040



• **MGBG-604C**



BL / WH / IV
● ○ ●

Panel	Tempered glass
Pan support	Cast iron
Knob material	Metal
Heat Power(kW)	1.0 / 1.75 / 1.75 / 3.3
Optional	Safety device (FFD)
Product Size (mm)	600 (W) x 510 (D) x 105 (H)
Cut-out Size (mm)	560 (W) x 480 (D)
Packing Size (mm)	646 (W) x 560 (D) x 155 (H)
Loading (20'/40'/40HQ)	540 / 1080 / 1200



• **MGBS-604TB**



SS / BL
● ●

Panel	Black Nano-Painting
Pan support	Cast iron
Knob material	Metal
Heat Power(kW)	1.0 / 1.75 / 1.75 / 3.3
Optional	Safety device (FFD)
Product Size (mm)	585 (W) x 505 (D) x 95 (H)
Cut-out Size (mm)	560 (W) x 480 (D)
Packing Size (mm)	640 (W) x 540(D) x 150 (H)
Loading (20'/40'/40HQ)	540/1120/1310



• **MGBG-905C**



BL / WH / IV
● ○ ●

Panel	Tempered glass
Pan support	Cast iron
Knob material	Metal
Heat Power(kW)	1.0 / 1.75 / 1.75 / 2.7 / 3.3
Optional	Safety device (FFD)
Product Size (mm)	900 (W) x 510 (D) x 105 (H)
Cut-out Size (mm)	830 (W) x 470 (D)
Packing Size (mm)	960 (W) x 568 (D) x 178 (H)
Loading (20'/40'/40HQ)	290 / 600 / 710



• **MGBS-765TB**



Panel	Black Nano-Painting
Pan support	Cast iron
Knob material	Metal
Heat Power(kW)	1.0 / 1.75 / 1.75 / 2.7 / 3.3
Optional	Safety device (FFD)
Product Size (mm)	760 (W) x 510 (D) x 97(H)
Cut-out Size (mm)	730 (W) x 480 (D)
Packing Size (mm)	820 (W) x 540(D) x 150 (H)
Loading (20'/40'/40HQ)	420 / 870 / 1020





• **MGBG-604M**



BL / WH / IV
● ○ ●

Panel	Tempered glass
Pan support	Cast iron
Knob material	Metal
Heat Power(kW)	1.0 / 1.75 / 1.75 / 3.3
Optional	Safety device (FFD)
Product Size (mm)	600 (W) x 510 (D) x 105 (H)
Cut-out Size (mm)	560 (W) x 480 (D)
Packing Size (mm)	646 (W) x 560 (D) x 155 (H)
Loading (20'/40'/40HQ)	540 / 1080 / 1200



• **MGBG-604C**



BL / WH / IV
● ○ ●

Panel	Tempered glass
Pan support	Cast iron
Knob material	Metal
Heat Power(kW)	1.0 / 1.75 / 1.75 / 3.3
Optional	Safety device (FFD)
Product Size (mm)	600 (W) x 510 (D) x 105 (H)
Cut-out Size (mm)	560 (W) x 480 (D)
Packing Size (mm)	646 (W) x 560 (D) x 155 (H)
Loading (20'/40'/40HQ)	540 / 1080 / 1200



• **MGBG-604**



BL / WH / IV
● ○ ●

Panel	Tempered glass
Pan support	Cast iron
Knob material	Metal
Heat Power(kW)	1.0 / 1.75 / 1.75 / 3.3
Optional	Safety device (FFD)
Product Size (mm)	600 (W) x 510 (D) x 105 (H)
Cut-out Size (mm)	560 (W) x 480 (D)
Packing Size (mm)	646 (W) x 560 (D) x 155 (H)
Loading (20'/40'/40HQ)	540 / 1080 / 1200



• **MGBS-604B4**



SS / BL
● ●

Panel	Stainless steel
Pan support	Cast iron
Knob material	Metal
Heat Power(kW)	1.0 / 1.75 / 1.75 / 3.3
Optional	Safety device (FFD)
Product Size (mm)	585 (W) x 505 (D) x 95 (H)
Cut-out Size (mm)	560 (W) x 480 (D)
Packing Size (mm)	640 (W) x 540(D) x 150 (H)
Loading (20'/40'/40HQ)	540/1120/1310



• **MGBS-604D**



SS / BL
● ●

Panel	Stainless steel
Pan support	Cast iron
Knob material	Metal
Heat Power(kW)	1.0 / 1.75 / 1.75 / 3.3
Optional	Safety device (FFD)
Product Size (mm)	585 (W) x 505 (D) x 95 (H)
Cut-out Size (mm)	560 (W) x 480 (D)
Packing Size (mm)	640 (W) x 540(D) x 150 (H)
Loading (20'/40'/40HQ)	540/1120/1310



• **MGBS-604A**



SS / BL
● ●

Panel	Stainless steel
Pan support	Cast iron
Knob material	Metal
Heat Power(kW)	1.0 / 1.75 / 1.75 / 3.3
Optional	Safety device (FFD)
Product Size (mm)	585 (W) x 505 (D) x 95 (H)
Cut-out Size (mm)	560 (W) x 480 (D)
Packing Size (mm)	640 (W) x 540(D) x 150 (H)
Loading (20'/40'/40HQ)	540/1120/1310





• **MGBG-604ME**



BL / WH / IV
● ○ ●

Panel	Tempered glass
Pan support	Wide Wire
Knob material	Bakelite
Heat Power(kW)	1.0 / 1.75 / 1.75 / 2.7
Optional	Safety device (FFD)
Product Size (mm)	600 (W) x 510 (D) x 105 (H)
Cut-out Size (mm)	560 (W) x 480 (D)
Packing Size (mm)	646 (W) x 560 (D) x 155 (H)
Loading (20'/40'/40HQ)	540 / 1080 / 1200



• **MGBG-604CE**



BL / WH / IV
● ○ ●

Panel	Tempered glass
Pan support	Wire
Knob material	Bakelite
Heat Power(kW)	1.0 / 1.75 / 1.75 / 2.7
Optional	Safety device (FFD)
Product Size (mm)	600 (W) x 510 (D) x 105 (H)
Cut-out Size (mm)	560 (W) x 480 (D)
Packing Size (mm)	646 (W) x 560 (D) x 155 (H)
Loading (20'/40'/40HQ)	540 / 1080 / 1200



• **MGBG-604FE**



BL / WH / IV
● ○ ●

Panel	Tempered glass
Pan support	Wire
Knob material	Bakelite
Heat Power(kW)	1.0 / 1.75 / 1.75 / 2.7
Optional	Safety device (FFD)
Product Size (mm)	600 (W) x 510 (D) x 105 (H)
Cut-out Size (mm)	560 (W) x 480 (D)
Packing Size (mm)	646 (W) x 560 (D) x 155 (H)
Loading (20'/40'/40HQ)	540 / 1080 / 1200



• **MGBS-604B4E**



SS / BL
● ●

Panel	Stainless steel
Pan support	Wire
Knob material	Bakelite
Heat Power(kW)	1.0 / 1.75 / 1.75 / 2.7
Optional	Safety device (FFD)
Product Size (mm)	585 (W) x 505 (D) x 95 (H)
Cut-out Size (mm)	560 (W) x 480 (D)
Packing Size (mm)	640 (W) x 540(D) x 150 (H)
Loading (20'/40'/40HQ)	540/1120/1310



• **MGBS-604DE**



SS / BL
● ●

Panel	Stainless steel
Pan support	Wire
Knob material	Bakelite
Heat Power(kW)	1.0 / 1.75 / 1.75 / 2.7
Optional	Safety device (FFD)
Product Size (mm)	585 (W) x 505 (D) x 95 (H)
Cut-out Size (mm)	560 (W) x 480 (D)
Packing Size (mm)	640 (W) x 540(D) x 150 (H)
Loading (20'/40'/40HQ)	540/1120/1310



• **MGBS-604AE**



SS / BL
● ●

Panel	Stainless steel
Pan support	Wire
Knob material	Bakelite
Heat Power(kW)	1.0 / 1.75 / 1.75 / 2.7
Optional	Safety device (FFD)
Product Size (mm)	585 (W) x 505 (D) x 95 (H)
Cut-out Size (mm)	560 (W) x 480 (D)
Packing Size (mm)	640 (W) x 540(D) x 150 (H)
Loading (20'/40'/40HQ)	540/1120/1310





• **MGBG-604M**



BL / WH / IV
● ○ ●

Panel	Tempered glass
Pan support	Cast iron
Knob material	Metal
Heat Power(kW)	1.0 / 1.75 / 1.75 / 3.3
Optional	Safety device (FFD)
Product Size (mm)	600 (W) x 510 (D) x 105 (H)
Cut-out Size (mm)	560 (W) x 480 (D)
Packing Size (mm)	646 (W) x 560 (D) x 155 (H)
Loading (20'/40'/40HQ)	540 / 1080 / 1200



• **MGBG-453M**



BL / WH / IV
● ○ ●

Panel	Tempered glass
Pan support	Cast iron
Knob material	Metal
Heat Power(kW)	1.0 / 1.75 / 3.3
Optional	Safety device (FFD)
Product Size (mm)	450 (W) x 500 (D) x 105 (H)
Cut-out Size (mm)	410 (W) x 465 (D)
Packing Size (mm)	515 (W) x 565 (D) x 147 (H)
Loading (20'/40'/40HQ)	654 / 1355 / 1589



• **MGBG-312M**



BL / WH / IV
● ○ ●

Panel	Tempered glass
Pan support	Cast iron
Knob material	Metal
Heat Power(kW)	1.0 / 3.3
Optional	Safety device (FFD)
Product Size (mm)	310 (W) x 515 (D) x 105 (H)
Cut-out Size (mm)	265 (W) x 475 (D)
Packing Size (mm)	550 (W) x 350(D) x 153 (H)
Loading (20'/40'/40HQ)	990 / 1810 / 2040



• **MGBS-604B4**



SS / BL NP
● ●

Panel	Black Nano-Painting
Pan support	Cast iron
Knob material	Metal
Heat Power(kW)	1.0 / 1.75 / 1.75 / 3.3
Optional	Safety device (FFD)
Product Size (mm)	585 (W) x 505 (D) x 95 (H)
Cut-out Size (mm)	560 (W) x 480 (D)
Packing Size (mm)	640 (W) x 540(D) x 150 (H)
Loading (20'/40'/40HQ)	540/1120/1310



• **MGBS-603A**



SS / BL NP
● ●

Panel	Black Nano-Painting
Pan support	Cast iron
Knob material	Metal
Heat Power(kW)	1.75 / 2.7 / 3.3
Optional	Safety device (FFD)
Product Size (mm)	585 (W) x 505 (D) x 95 (H)
Cut-out Size (mm)	560 (W) x 480 (D)
Packing Size (mm)	640 (W) x 540(D) x 150 (H)
Loading (20'/40'/40HQ)	540/1120/1310



• **MGBS-312B4**



SS / BL NP
● ●

Panel	Black Nano-Painting
Pan support	Cast iron
Knob material	Metal
Heat Power(kW)	1.0 / 3.3
Optional	Safety device (FFD)
Product Size (mm)	310 (W) x 510 (D) x 95 (H)
Cut-out Size (mm)	265 (W) x 475 (D)
Packing Size (mm)	550 (W) x 360 (D) x 153 (H)
Loading (20'/40'/40HQ)	990/1810/2040





• **MGBG-604ME**



BL / WH / IV
● ○ ●

Panel	Tempered glass
Pan support	Wire
Knob material	Bakelite
Heat Power(kW)	1.0 / 1.75 / 1.75 / 2.7
Optional	Safety device (FFD)
Product Size (mm)	600 (W) x 510 (D) x 105 (H)
Cut-out Size (mm)	560 (W) x 480 (D)
Packing Size (mm)	646 (W) x 560 (D) x 155 (H)
Loading (20'/40'/40HQ)	540 / 1080 / 1200



• **MGBG-453ME**



BL / WH / IV
● ○ ●

Panel	Tempered glass
Pan support	Wire
Knob material	Bakelite
Heat Power(kW)	1.0 / 1.75 / 3.3
Optional	Safety device (FFD)
Product Size (mm)	450 (W) x 500 (D) x 105 (H)
Cut-out Size (mm)	410 (W) x 465 (D)
Packing Size (mm)	515 (W) x 565 (D) x 147 (H)
Loading (20'/40'/40HQ)	654 / 1355 / 1589



• **MGBG-312ME**



BL / WH / IV
● ○ ●

Panel	Tempered glass
Pan support	Wire
Knob material	Bakelite
Heat Power(kW)	1.0 / 2.7
Optional	Safety device (FFD)
Product Size (mm)	310 (W) x 515 (D) x 105 (H)
Cut-out Size (mm)	265 (W) x 475 (D)
Packing Size (mm)	550 (W) x 350(D) x 153 (H)
Loading (20'/40'/40HQ)	990 / 1810 / 2040



• **MGBS-604B4E**



SS / BL E
● ●

Panel	Black Enamelled
Pan support	Wire
Knob material	Bakelite
Heat Power(kW)	1.0 / 1.75 / 1.75 / 2.7
Optional	Safety device (FFD)
Product Size (mm)	585 (W) x 505 (D) x 95 (H)
Cut-out Size (mm)	560 (W) x 480 (D)
Packing Size (mm)	640 (W) x 540(D) x 150 (H)
Loading (20'/40'/40HQ)	540/1120/1310



• **MGBS-603AE**



SS / BL E
● ●

Panel	Black Enamelled
Pan support	Wire
Knob material	Bakelite
Heat Power(kW)	1.0 / 2.7 / 3.3
Optional	Safety device (FFD)
Product Size (mm)	585 (W) x 505 (D) x 95 (H)
Cut-out Size (mm)	560 (W) x 480 (D)
Packing Size (mm)	640 (W) x 540(D) x 150 (H)
Loading (20'/40'/40HQ)	540/1120/1310



• **MGBS-312B4E**



SS / BL E
● ●

Panel	Black Enamelled
Pan support	Wire
Knob material	Bakelite
Heat Power(kW)	1.0 / 2.7
Optional	Safety device (FFD)
Product Size (mm)	310 (W) x 510 (D) x 95 (H)
Cut-out Size (mm)	265 (W) x 475 (D)
Packing Size (mm)	550 (W) x 360 (D) x 153 (H)
Loading (20'/40'/40HQ)	990/1810/2040





• **MGBG-705M**



BL / WH / IV
● ○ ●

Panel	Tempered glass
Pan support	Cast iron
Knob material	Metal
Heat Power(kW)	1.0 / 1.75 / 1.75 / 2.7 / 3.3
Optional	Safety device (FFD)
Product Size (mm)	700 (W) x 510 (D) x 105 (H)
Cut-out Size (mm)	560 (W) x 480 (D)
Packing Size (mm)	745 (W) x 570 (D) x 180 (H)
Loading (20'/40'/40HQ)	320 / 630 / 750



• **MGBG-775G**



BL / WH / IV
● ○ ●

Panel	Tempered glass
Pan support	Cast iron
Knob material	Metal
Heat Power(kW)	1.0 / 1.75 / 1.75 / 2.7 / 3.3
Optional	Safety device (FFD)
Product Size (mm)	770 (W) x 510 (D) x 105 (H)
Cut-out Size (mm)	560 (W) x 480 (D)
Packing Size (mm)	816 (W) x 556(D) x 155 (H)
Loading (20'/40'/40HQ)	420 / 870 / 1020



• **MGBG-875G**



BL / WH / IV
● ○ ●

Panel	Tempered glass
Pan support	Cast iron
Knob material	Metal
Heat Power(kW)	1.0 / 1.75 / 1.75 / 2.7 / 3.3
Optional	Safety device (FFD)
Product Size (mm)	870 (W) x 510 (D) x 105 (H)
Cut-out Size (mm)	730 (W) x 480 (D)
Packing Size (mm)	946 (W) x 551(D) x 155 (H)
Loading (20'/40'/40HQ)	290 / 600 / 710



• **MGBS-765A**



SS / BL
● ●

Panel	Stainless steel
Pan support	Cast iron
Knob material	Metal
Heat Power(kW)	1.0 / 1.75 / 1.75 / 2.7 / 3.3
Optional	Safety device (FFD)
Product Size (mm)	760 (W) x 510 (D) x 97(H)
Cut-out Size (mm)	730 (W) x 480 (D)
Packing Size (mm)	820 (W) x 540(D) x 150 (H)
Loading (20'/40'/40HQ)	420 / 870 / 1020



• **MGBS-765B4**



SS / BL
● ●

Panel	Stainless steel
Pan support	Cast iron
Knob material	Metal
Heat Power(kW)	1.0 / 1.75 / 1.75 / 2.7 / 3.3
Optional	Safety device (FFD)
Product Size (mm)	760 (W) x 510 (D) x 97(H)
Cut-out Size (mm)	730 (W) x 480 (D)
Packing Size (mm)	820 (W) x 540(D) x 150 (H)
Loading (20'/40'/40HQ)	420 / 870 / 1020



• **MGBS-865B4**



SS / BL
● ●

Panel	Stainless steel
Pan support	Cast iron
Knob material	Metal
Heat Power(kW)	1.0 / 1.75 / 1.75 / 2.7 / 3.3
Optional	Safety device (FFD)
Product Size (mm)	860 (W) x 510 (D) x 97(H)
Cut-out Size (mm)	830 (W) x 480 (D)
Packing Size (mm)	920 (W) x 540(D) x 150 (H)
Loading (20'/40'/40HQ)	290 / 600 / 710



NEW DESIGN GAS HOB



MHBG-604

BL ● / WH ○ / IV ○

Panel	Tempered glass
Panel Support	Cast iron
Knob Material	Metal
Heat Power(kW)	1.2/1.8(Electricity) / 1.0/3.3(Gas)
Optional	Safety device (FFD)
Product Size (mm)	600 (W) x 510 (D) x 105 (H)
Cut-out Size (mm)	560 (W) x 480 (D)
Packing Size (mm)	646 (W) x 560 (D) x 155 (H)
Loading (20'/40'/40HQ)	540 / 1080 / 1200



MHBS-604T

SS ○ / BL ●

Panel	Tempered glass
Panel Support	Cast iron
Knob Material	Metal
Heat Power(kW)	1.5(Electricity) / 1.0 / 2.7 / 3.3(Gas)
Optional	Safety device (FFD)
Product Size (mm)	585 (W) x 505 (D) x 95 (H)
Cut-out Size (mm)	560 (W) x 480 (D)
Packing Size (mm)	640 (W) x 540(D) x 150 (H)
Loading (20'/40'/40HQ)	540/1120/1310



MGBG-453T

BL ● / WH ○ / IV ○

Panel	Tempered glass
Panel Support	Cast iron
Knob Material	Touch control
Heat Power(kW)	1.0 / 1.75 / 3.3
Optional	Safety device (FFD)
Product Size (mm)	450 (W) x 500 (D) x 105 (H)
Cut-out Size (mm)	410 (W) x 465 (D)
Packing Size (mm)	515 (W) x 565 (D) x 147 (H)
Loading (20'/40'/40HQ)	654 / 1355 / 1589



MGBG-453K

BL ● / WH ○ / IV ○

Panel	Tempered glass
Panel Support	Cast iron
Knob Material	Touch control
Heat Power(kW)	1.0 / 1.75 / 3.3
Optional	Safety device (FFD)
Product Size (mm)	450 (W) x 500 (D) x 105 (H)
Cut-out Size (mm)	410 (W) x 465 (D)
Packing Size (mm)	515 (W) x 565 (D) x 147 (H)
Loading (20'/40'/40HQ)	654 / 1355 / 1589



NEW DESIGN GAS HOB(LED KNOB)

LED KNOB

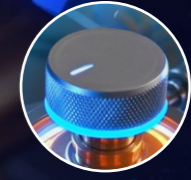

Blue Light



White Light



Red Light



MGBS-604L



Panel	Stainless steel
Panel Support	Cast iron
Knob Material	Metal
Heat Power(kW)	1.0 / 1.75 / 1.75 / 3.3
Optional	Safety device (FFD)
Product Size (mm)	585 (W) x 505 (D) x 95 (H)
Cut-out Size (mm)	560 (W) x 480 (D)
Packing Size (mm)	640 (W) x 540(D) x 150 (H)
Loading (20'/40'/40HQ)	540/1120/1310



MGBG-604L



Panel	Tempered glass
Panel Support	Cast iron
Knob Material	Metal
Heat Power(kW)	1.0 / 1.75 / 1.75 / 3.3
Optional	Safety device (FFD)
Product Size (mm)	600 (W) x 510 (D) x 105 (H)
Cut-out Size (mm)	560 (W) x 480 (D)
Packing Size (mm)	646 (W) x 560 (D) x 155 (H)
Loading (20'/40'/40HQ)	540 / 1080 / 1200



Hammer Series

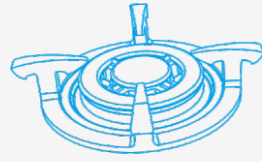

Crown Series

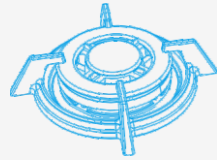

Diamond Series

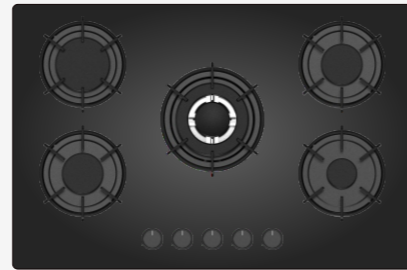
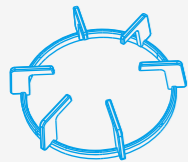

Classic Series



Snowflake Series



Football Field Series

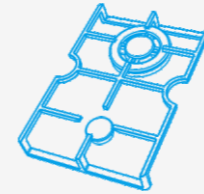

Small Waist Series



Take Off Series



Tangram Series



Hourglass Series





Fast Cook

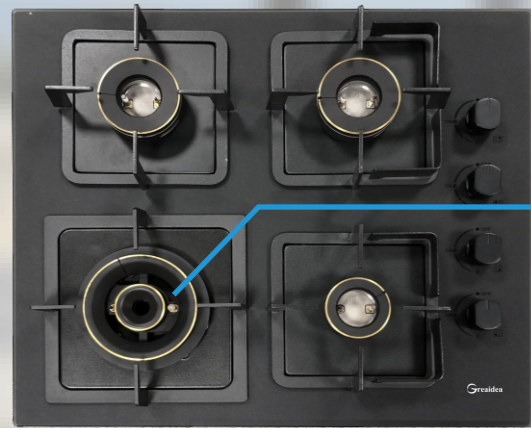

Double Ring Brass Burner



5.2kW

Precise Flame Control



9 Range Valve

Hood & Hob One Pack



600mm Slim Range Hood



750mm Slim Range Hood



600mm 4 Burner Gas Hob



760mm 5 Burner Gas Hob



First:
Bottom layer is slim range hood

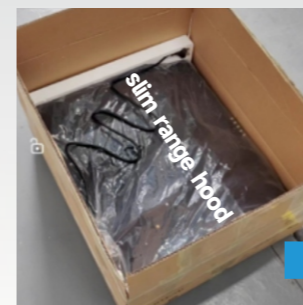

Second:
Add a paper card to protect the surface of range hood



Third:
Upper layer is slim range hood



Fourth:
Add corner protectors





MCHS-6021RT

SS / BL / WH

Width	600mm
Material	Painted body or S/S body
Airflow	180m ³ /h
Motor Type	1x100W
Control Type	Piano switch control
Level of Speed	3 speeds
Lighting	1x2W LED Lamp
Filter Type	3 Layer aluminium grease fliter Activated carbon fliter
Air Outlet	120mm
Packing size	633x522x132mm (600mm)
Loading QTY(20/40/40HQ)	640 / 1320 / 1550 (600mm)

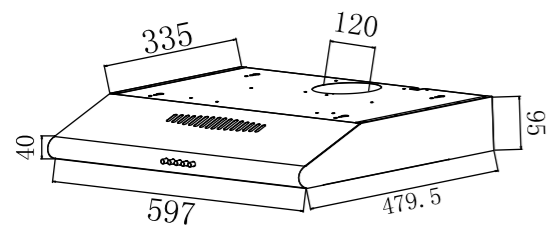

MCHS-6021RB

SS / BL / WH

Width	600mm
Material	Painted body or S/S body
Airflow	180m ³ /h
Motor Type	1x100W
Control Type	Touch control
Level of Speed	3 speeds
Lighting	1x2W LED Lamp
Filter Type	3 Layer aluminium grease fliter Activated carbon fliter
Air Outlet	120mm
Packing size	633x522x132mm (600mm)
Loading QTY(20/40/40HQ)	640 / 1320 / 1550 (600mm)

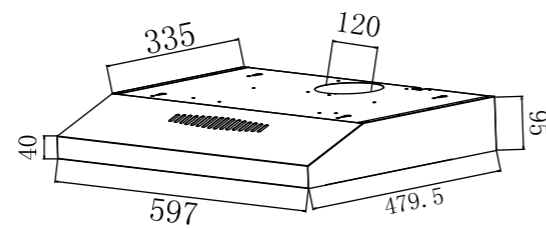

MCHS-6021F

SS / BL / WH

Width	600mm
Material	Painted body or S/S body
Airflow	180m ³ /h
Motor Type	1x100W
Control Type	Piano switch control
Level of Speed	3 speeds
Lighting	1x2W LED Lamp
Filter Type	3 Layer aluminium grease fliter Activated carbon fliter
Air Outlet	120mm
Packing size	633x522x132mm (600mm)
Loading QTY(20/40/40HQ)	640 / 1320 / 1550 (600mm)

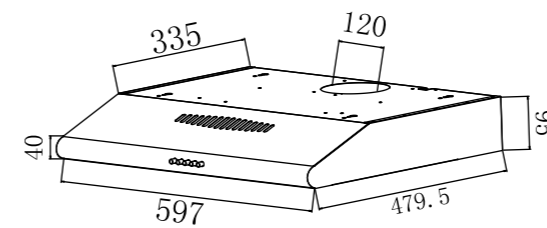

MCHS-6021FB

SS / BL / WH

Width	600mm
Material	Painted body or S/S body
Airflow	180m ³ /h
Motor Type	1x100W
Control Type	Touch control
Level of Speed	3 speeds
Lighting	1x2W LED Lamp
Filter Type	3 Layer aluminium grease fliter Activated carbon fliter
Air Outlet	120mm
Packing size	633x522x132mm (600mm)
Loading QTY(20/40/40HQ)	640 / 1320 / 1550 (600mm)

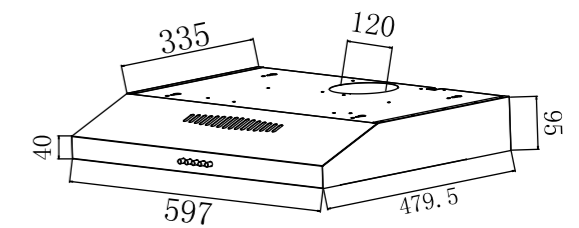



MCHS-6003SL SS  / BL  / WH 

Width	600mm
Material	Painted body or S/S body
Airflow	225m ³ /h
Motor Type	1x100W
Control Type	Mechanical Rocker Control
Level of Speed	2 speeds
Lighting	2x1.5W LED Lamp
Filter Type	3 Layer aluminium grease fliter Activated carbon fliter
Air Outlet	150mm
Packing size	650x260x358mm (600mm)
Loading QTY(20/40/40HQ)	530 / 1100 / 1270 (600mm)

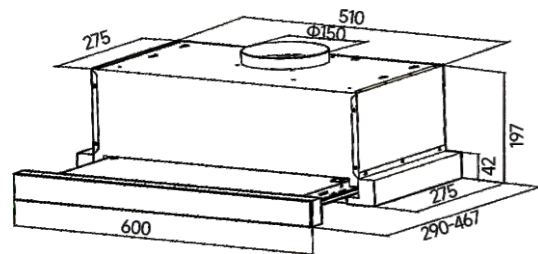

MCHS-6003SEL SS  / BL  / WH 

Width	600mm
Material	Painted body or S/S body
Airflow	225m ³ /h
Motor Type	1x100W
Control Type	Touch control
Level of Speed	2 speeds
Lighting	2x1.5W LED Lamp
Filter Type	3 Layer aluminium grease fliter Activated carbon fliter
Air Outlet	150mm
Packing size	650x260x358mm (600mm)
Loading QTY(20/40/40HQ)	530 / 1100 / 1270 (600mm)

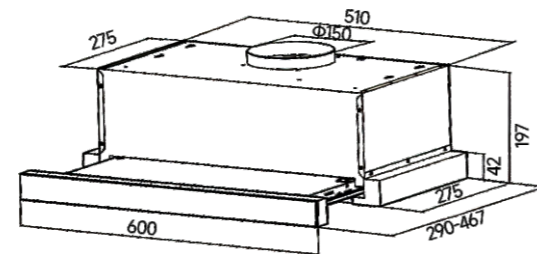

MCHW-H602 SS  / BL  / WH 

Width	600/mm
Material	Black painted body, Black tempered glass
Airflow	600m ³ /h
Motor Type	1x180W
Control Type	Touch control Gesture control sensor
Level of Speed	3 speeds
Lighting	2x1.5W LED Lamp
Filter Type	5 Layer aluminium grease fliter Activated carbon fliter
Air Outlet	150mm
Packing size	655x455x518mm (600mm)
Loading QTY(20/40/40HQ)	240 / 370 / 430 (600mm)

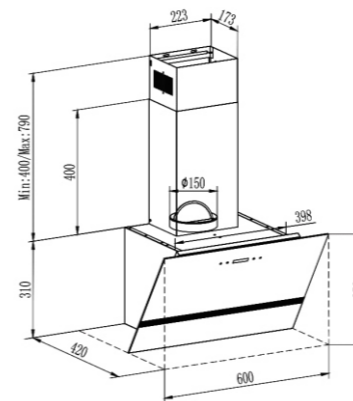

MCHW-H603 SS  / BL  / WH 

Width	600mm
Material	Painted body or S/S body
Airflow	600m ³ /h
Motor Type	1 x 180W
Control Type	Piano switch control
Level of Speed	3 speeds
Lighting	2x1.5W LED Lamp
Filter Type	3 Layer aluminium grease fliter Activated carbon fliter
Air Outlet	150mm
Packing size	641x465x521mm (600mm)
Loading QTY(20/40/40HQ)	240 / 370 / 430 (600mm)

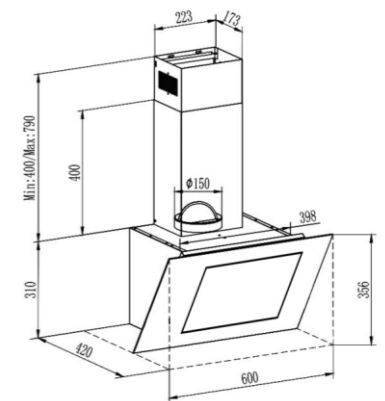



GCHT-60/75/90B SS  / BL  / WH 

Width	600/750/900mm
Material	Painted body or S/S body
Airflow	600m ³ /h
Motor Type	1x220W
Control Type	Piano switch control
Level of Speed	3 speeds
Lighting	2x2W LED Lamp
Filter Type	3 Layer aluminium grease fliter Activated carbon fliter
Air Outlet	150mm
Packing size	660x490x420mm (600mm) 810x490x420mm (750mm) 960x490x420mm (900mm)
Loading QTY(20/40/40HQ)	230 / 480 / 560 (600mm) 250 / 390 / 460 (750mm) 210 / 330 / 390 (900mm)

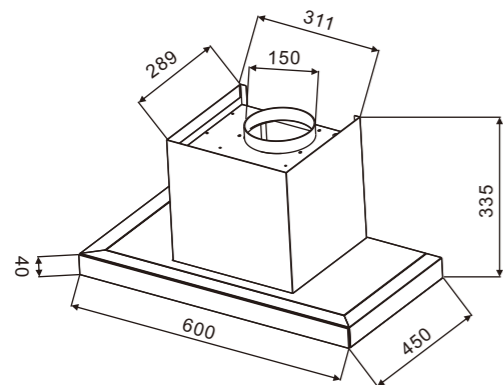

GCHT-60/75/90ST SS  / BL  / WH 

Width	600/750/900mm
Material	Painted body or S/S body
Airflow	600m ³ /h
Motor Type	1 x 220W
Control Type	Touch control
Level of Speed	2 speeds
Lighting	2x2W LED Lamp
Filter Type	3 Layer aluminium grease fliter Activated carbon fliter
Air Outlet	150mm
Packing size	660x490x420mm (600mm) 810x490x420mm (750mm) 960x490x420mm (900mm)
Loading QTY(20/40/40HQ)	230 / 480 / 560 (600mm) 250 / 390 / 460 (750mm) 210 / 330 / 390 (900mm)

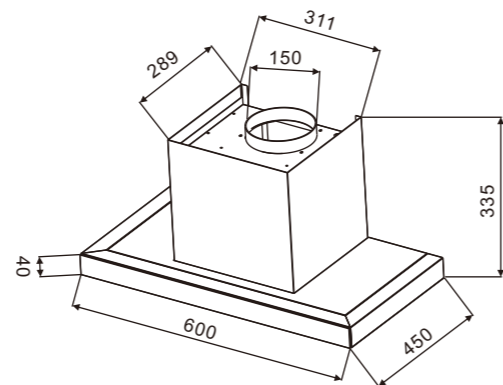

GCHT-60/75/90SB SS  / BL  / WH 

Width	600/750/900mm
Material	Painted body or S/S body
Airflow	600m ³ /h
Motor Type	1x220W
Control Type	Piano switch control
Level of Speed	3 speeds
Lighting	1x2W LED Lamp
Filter Type	Baffle filter Activated carbon fliter
Air Outlet	150mm
Packing size	660x430x420mm (600mm) 810x430x420mm (750mm) 960x430x420mm (900mm)
Loading QTY(20/40/40HQ)	230 / 480 / 560 (600mm) 250 / 390 / 460 (750mm) 210 / 330 / 390 (900mm)

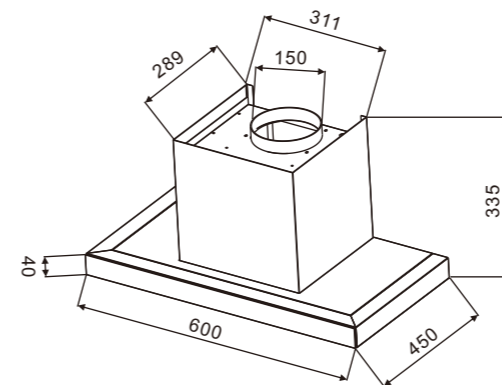

GCHT-60/75/90BBT SS  / BL  / WH 

Width	600/750/900mm
Material	Painted body or S/S body
Airflow	600m ³ /h
Motor Type	1 x 220W
Control Type	Touch control
Level of Speed	2 speeds
Lighting	1x2W LED Lamp
Filter Type	Baffle filter Activated carbon fliter
Air Outlet	150mm
Packing size	660x430x420mm (600mm) 810x430x420mm (750mm) 960x430x420mm (900mm)
Loading QTY(20/40/40HQ)	230 / 480 / 560 (600mm) 250 / 390 / 460 (750mm) 210 / 330 / 390 (900mm)

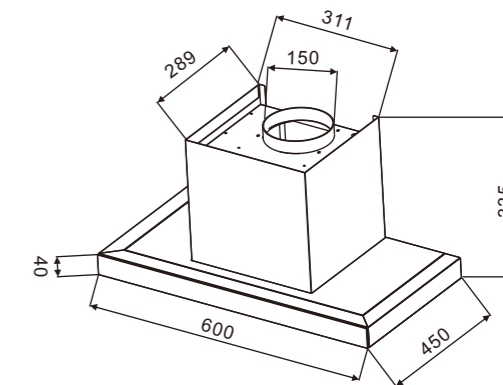



MCHB-60 SS  / BL  / WH 

Width	600mm
Material	Painted body or S/S body
Airflow	600m ³ /h
Motor Type	1x220W
Control Type	Piano switch control
Level of Speed	3 speeds
Lighting	2x3W LED Lamp
Filter Type	3 Layer aluminium grease fliter Activated carbon fliter
Air Outlet	120mm
Packing size	650x365x357mm (500mm)
Loading QTY(20/40/40HQ)	390 / 800 / 940 (500mm)

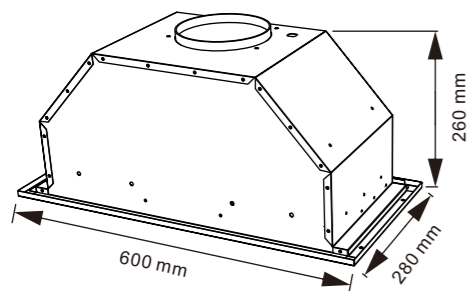

MCHB-60 SS  / BL  / WH 

Width	600mm
Material	Painted body or S/S body
Airflow	260m ³ /h
Motor Type	1x120W
Control Type	Piano switch control
Level of Speed	3 speeds
Lighting	2x3W LED Lamp
Filter Type	3 Layer aluminium grease fliter Activated carbon fliter
Air Outlet	120mm
Packing size	650x345x345mm (600mm)
Loading QTY(20/40/40HQ)	360 / 740 / 870 (600mm)

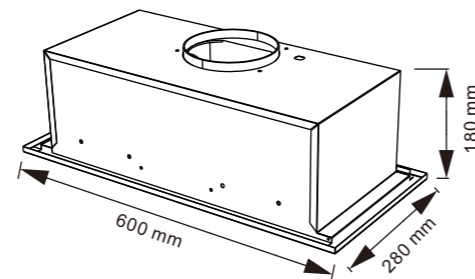

CXW-310-900JT3 BL 

Width	900mm
Material	S/S body, Black tempered glass
Airflow	1200m ³ /h
Motor Type	1x313W
Level of Speed	3 speeds
Lighting	2x1.5W LED
Air Outlet	180mm
Packing size	970x427x985mm (900mm)
Loading QTY(20/40/40HQ)	60 / 140 / 160 (900mm)

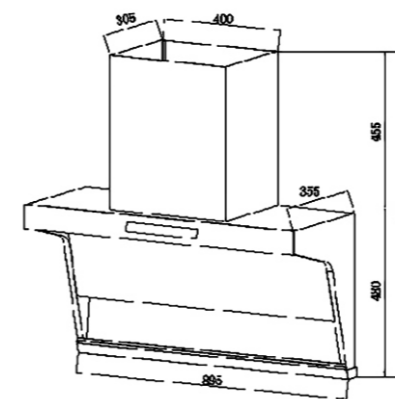

CXW-280-B02 BL 

Width	900mm
Material	Black painted body, Black tempered glass
Airflow	1200m ³ /h
Motor Type	1x280W
Level of Speed	6 speeds
Lighting	1x3W LED
Air Outlet	180mm
Packing size	960x255x600mm (900mm)
Loading QTY(20/40/40HQ)	190 / 390 / 460 (900mm)

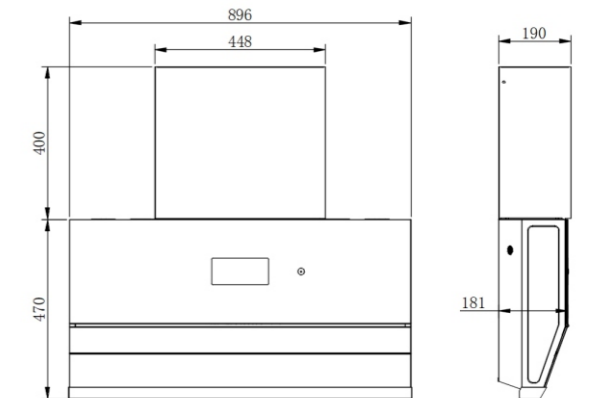

Range Hood Panel Option

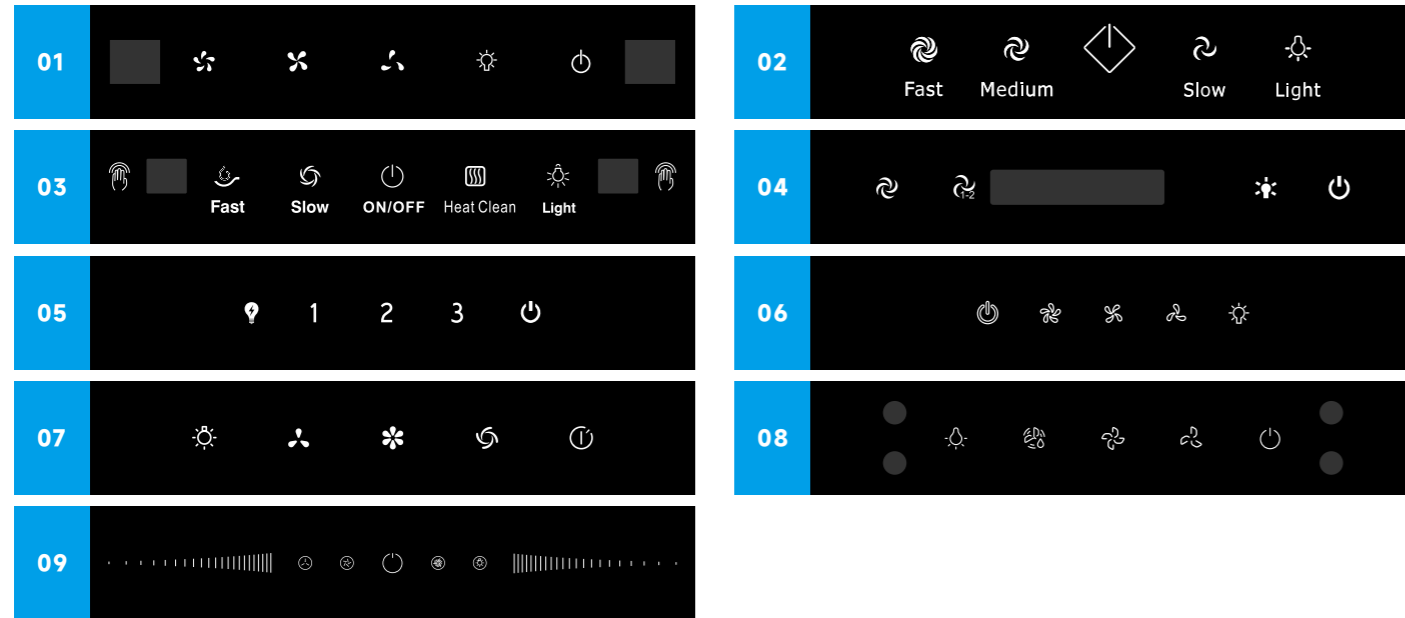

Slim Range Hood

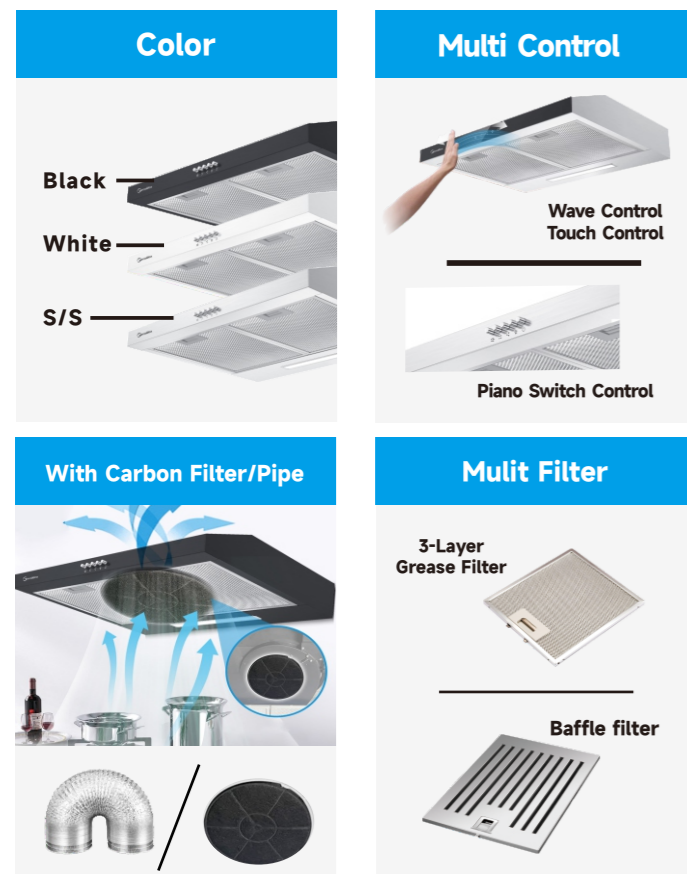

Telescopic Range Hood

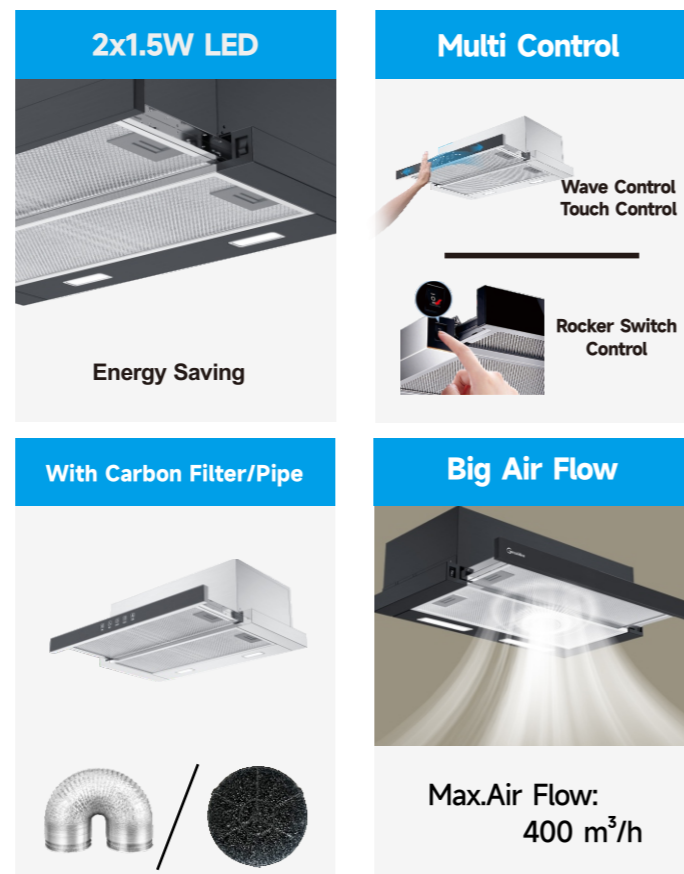

Built-in Multi-Burner Gas Hob Key Parts Option



Built-in Multi-Burner Gas Hob Panel Option

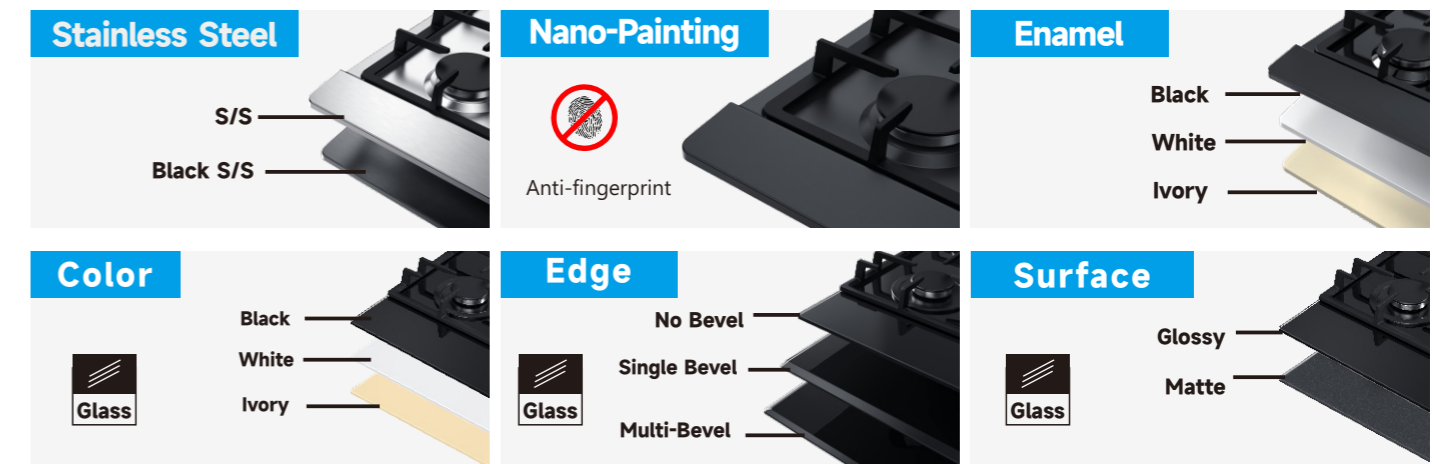

Built-in Multi-Burner Gas Hob Knob Option

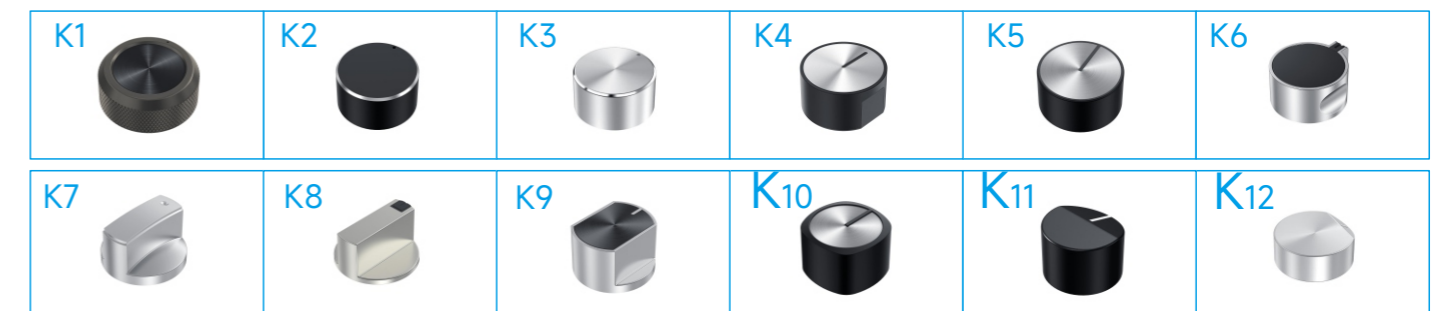

Gas Camping Stove



28000Btu x 2



With Ignitor



Lightweight And Portable



CAMPING STOVE

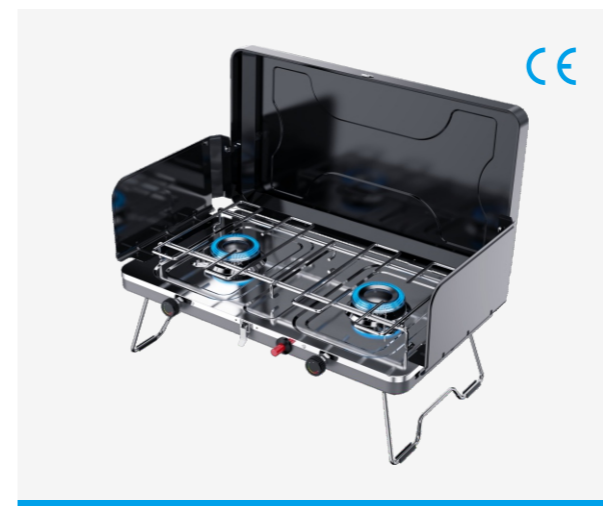

SG-203-16(2 Burners)

- Item Dimensions LxWxH: 560 x 320x 95mm
- Certificate: CE
- Power: 15000BTU x 2
- Input Pressure: 1bar/100kpa Pipe Valve KR-276Y15
- Ignition Device: 1 piezoelectric ignition system
- Loading (20'/40'/40HQ): 1400/2900/3100
- G.W. / N.W.: 4kg / 3.6kg
- Quantity: 4 pieces/master box



SG-208-79G29(2 Burners)

- Item Dimensions LxWxH: 420 x 230x 83mm
- Certificate: CE
- Power: 7000BTU x 2 (7.4MJ/h x 2, 2kW x 2, 150g/h x 2)
- Input Pressure: 1bar/100kpa Pipe Valve KR-276Y15
- Loading (20'/40'/40HQ): 2460/5010/6270
- G.W. / N.W.: 1.5kg / 1.3kg
- Quantity: 5 pieces/master box
- Accessories: valve body, 1 meter long pipe



About Us / Certificate

We developed the overseas market since 2000, exported our gas water heater more than 49 overseas countries. Moreover, we ranged the leading position in some overseas market for many years. In 2013, we increased the business development of our China domestic market and cooperated with many top brands in China. In November 2018, Greaidea invested around 1.2 million U.S. Dollars to upgrade hardware systems such as testing laboratories and assembly facilities. We are always focusing on customers' value, re-combing the recruitment of high talented human resource, keeping upgrading with the first-class manufacture facilities, under such great improvement, which definitely can support the long-term development of "Greaidea"

With abundant human, finance & material resource, we always pay great attention to the quality of products and dedicate all efforts to develop the new technology with creative idea, gradually to improve our reputation among competitors. With the support of comprehensive & precise testing equipment in each assembly line, as well as the mature quality control system, we have gained high reputation from honored customers both in domestic and overseas market.

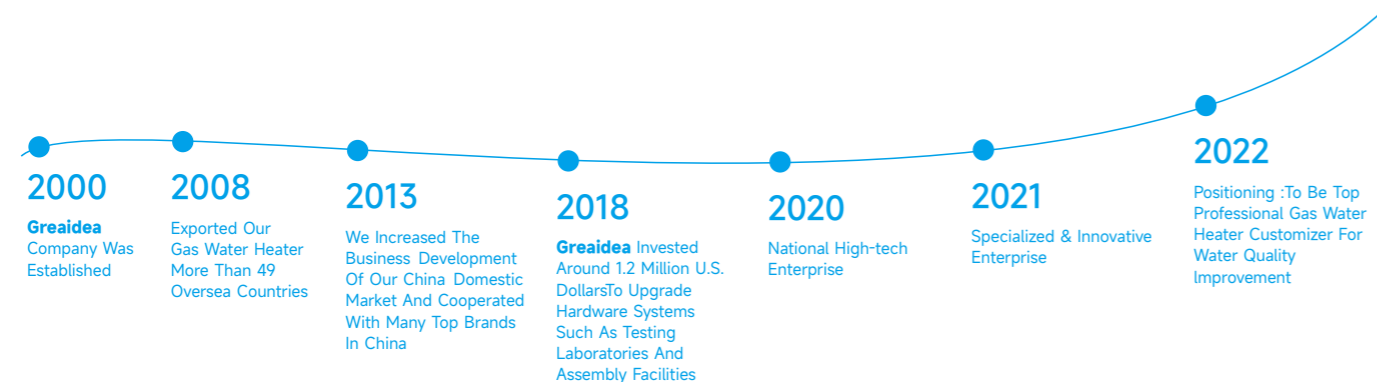

Vision: BEYOND YOUR IMAGINATION!

CULTURAL PRINCIPLE OF Greaidea

- ▶ Mutual Creation: Innovate new products with customers Introduce new management & technology with key suppliers
- ▶ Mutual Sharing: Knowledge sharing, skills sharing, experience sharing and happiness sharing
- ▶ Win-Win: Realize the Win-Win situation with our customer, our employees and social public

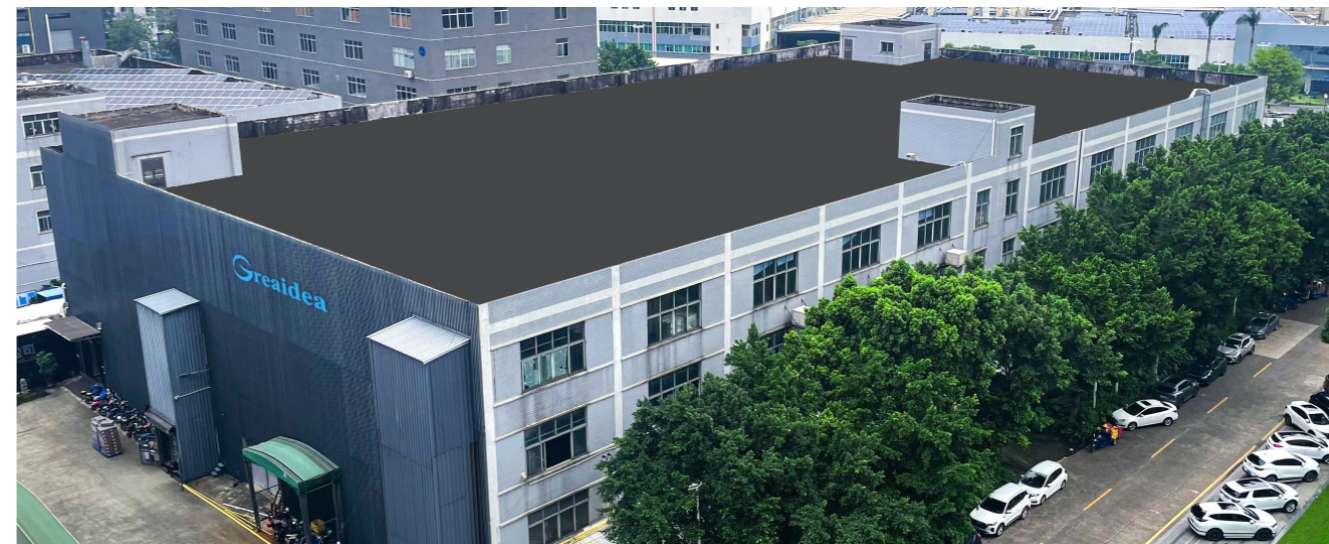



Production Team

- ▶ Production Line-40,000PCS monthly production capability
- ▶ We follow the 7S factory management system
- ▶ 3 Automatic assembly lines & 3 automatic packing machines

Assembly Process

Assembly



Assembly



Assembly



Assembly



Random test



Automatic Packing



Full assembly test



Half assembly test



Assembly



Quality Control

- ▶ Integrated Testing Lab Overview
- ▶ Comprehensive Testing Room
- ▶ Key Parts Performance Testing Room
- ▶ Environment And Packing Testing Room
- ▶ Individual Water And Gas Supply Base



Integrated Testing Lab



Life Testing Equipment



Key Parts Performance Testing Room



Water Heater Integrated Automatic Testing Equipment



Burner, Heat Exchanger And Gas Valve Testing Equipment



Integrated Testing Lab

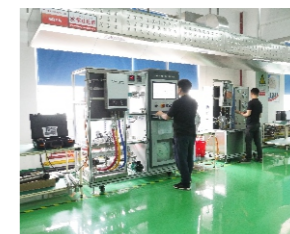

Integrated Testing Lab



Gas Chromatograph

White Panel Classical Design



JSD-W1(6L-20L)

JSD-W2(6L-20L)

JSD-W3(6L-20L)

- Exhaust Way: Flue Type/Force Exhaust Type
- Ignition Mode: Automatic Electrical Pulse Igniton
- Gas Type: LPG 2800PA; Natural Gas 1300PA/2000PA
- Rated Voltage: DC 3V / USB Type-C
- Rated Water Pressure: 0.01-0.8MPA
- Panel Material: White Powder Painting/Silver Metallic Painting
- Heating Status: Over Temperature \leq 2°C; Stability Time \leq 15 Seconds
- Connection Pipe Specs: Water Inlet: G1/2" Pipe; Water Outlet:G1/2" Pipe; Gas Input: G1/2" Pipe



Rated Water Output($\Delta t=25^{\circ}\text{C}$)L/Min	6L/min	7L/min	8L/min	10L/min
Rated Thermal Load	12KW	14KW	16KW	20KW
Product Size(MM)	440x300x120	490x310x140	520x310x140	550x330x180
Package Size(MM)	540x350x170	600x360x190	640x370x200	670x380x235
Loading Qty.(PCS)20FT/40FT/40HQ	880/1780/2050	685/1390/1620	600/1220/1420	455/950/1120

Rated Water Output($\Delta t=25^{\circ}\text{C}$)L/Min	12L/min	14L/min	16L/min	20L/min
Rated Thermal Load	24KW	28KW	32KW	40KW
Product Size(MM)	590x340x140	610x350x180	650x420x185	730x430x180
Package Size(MM)	705x390x200	725x400x240	750x470x235	880x470x250
Loading Qty.(PCS)20FT/40FT/40HQ	520/1060/1220	540/830/970	340/700/810	270/550/640

Full Colorful Glass



JSD-FG1(6L-20L)

JSD-FG2(6L-20L)

JSD-FG3(6L-20L)

- Exhaust Way: Flue Type/Force Exhaust Type
- Ignition Mode: Automatic Electrical Pulse Igniton
- Gas Type: LPG 2800PA; Natural Gas 1300PA/2000PA
- Rated Voltage: DC 3V / USB Type-C
- Rated Water Pressure: 0.01-0.8MPA
- Panel Material: White Powder Painting/Silver Metallic Painting
- Heating Status: Over Temperature \leq 2°C; Stability Time \leq 15 Seconds
- Connection Pipe Specs: Water Inlet: G1/2" Pipe; Water Outlet:G1/2" Pipe; Gas Input: G1/2" Pipe



Rated Water Output($\Delta t=25^{\circ}\text{C}$)L/Min	6L/min	7L/min	8L/min	10L/min
Rated Thermal Load	12KW	14KW	16KW	20KW
Product Size(MM)	440x300x120	490x310x140	520x310x140	550x330x180
Package Size(MM)	540x350x170	600x360x190	640x370x200	670x380x235
Loading Qty.(PCS)20FT/40FT/40HQ	880/1780/2050	685/1390/1620	600/1220/1420	455/950/1120

Rated Water Output($\Delta t=25^{\circ}\text{C}$)L/Min	12L/min	14L/min	16L/min	20L/min
Rated Thermal Load	24KW	28KW	32KW	40KW
Product Size(MM)	590x340x140	610x350x180	650x420x185	730x430x180
Package Size(MM)	705x390x200	725x400x240	750x470x235	880x470x250
Loading Qty.(PCS)20FT/40FT/40HQ	520/1060/1220	540/830/970	340/700/810	270/550/640

Constant Temperature Type



JSQ-CT2(13L)

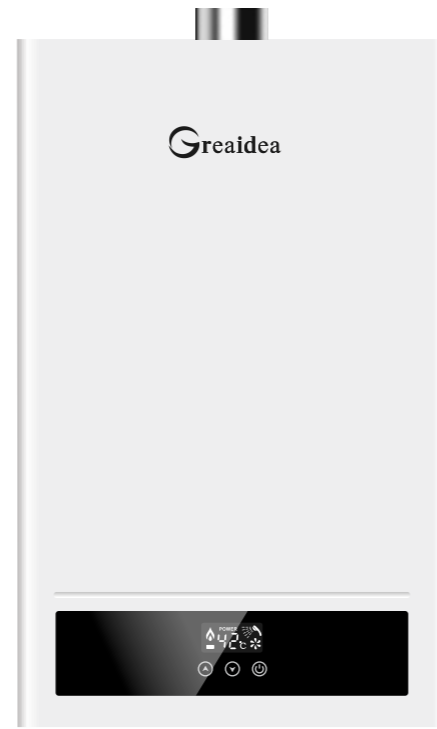

JSQ-CT4(12L-18L)

- Exhaust Way: Forced Exhaust Type
- Diameter of Smoke Exhaust: Φ60MM
- Ignition Mode: Automatic Electrical Pulse Igniton
- Gas Type: LPG/Natural Gas
- Rated Voltage: AC 220V/50HZ & AC 110V/60HZ
- Rated Water Pressure: 0.01~0.8MPA
- Panel Color: White / Grey
- Connection Pipe Specs: Water Inlet: G1/2" Pipe; Water Outlet:G1/2" Pipe; Gas Input: G1/2: Pipe



Rated Water Output(Δt=25°C)L/Min	12L/min	13L/min	16L/min	18L/min
Rated Thermal Load	24KW	26KW	32KW	36KW
Product Size(MM)	560x350x140	560x350x140	560x350x140	560x350x140
Package Size(MM)	685x405x215	685x405x215	685x405x215	685x405x215
Loading Qty.(PCS)20FT/40FT/40HQ	380/760/900	380/760/900	380/760/900	380/760/900

Remark: Unit and its Pipe packed separately.

Constant Temperature Type

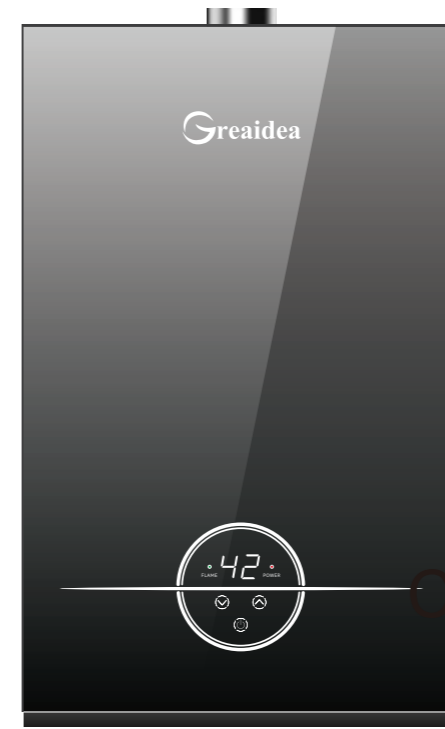

**JSQ*-G3(B)
(Glass Panel)**



**JSQ*-G5(B)
(Glass Panel)**

- Exhaust Way: Forced Exhaust Type
- Diameter of Smoke Exhaust: Φ60MM
- Ignition Mode: Automatic Electrical Pulse Igniton
- Gas Type: LPG/Natural Gas
- Rated Voltage: AC 220V/50HZ & AC 110V/60HZ
- Rated Water Pressure: 0.01~0.8MPA
- Panel Color: White / Grey
- Connection Pipe Specs: Water Inlet: G1/2" Pipe; Water Outlet:G1/2" Pipe; Gas Input: G1/2: Pipe



Rated Water Output(Δt=25°C)L/Min	12L/min	13L/min	16L/min	18L/min
Rated Thermal Load	24KW	26KW	32KW	36KW
Product Size(MM)	560x350x140	560x350x140	560x350x140	560x350x140
Package Size(MM)	685x405x215	685x405x215	685x405x215	685x405x215
Loading Qty.(PCS)20FT/40FT/40HQ	380/760/900	380/760/900	380/760/900	380/760/900

Remark: Unit and its Pipe packed separately.

ECO SERIES

Constant Temperature Gas Water Heater



5 YEAR WARRANTY



Silent Combustion



Durable Burner



White LED



Constant Temperature Type

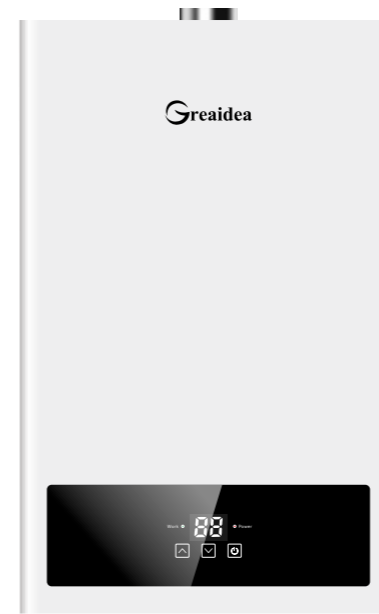

JSD-T01(12L)



JSC-T02(13L/16L)



JSC-T03(13L/16L)



JSC-CT3W



JSC-CT3B

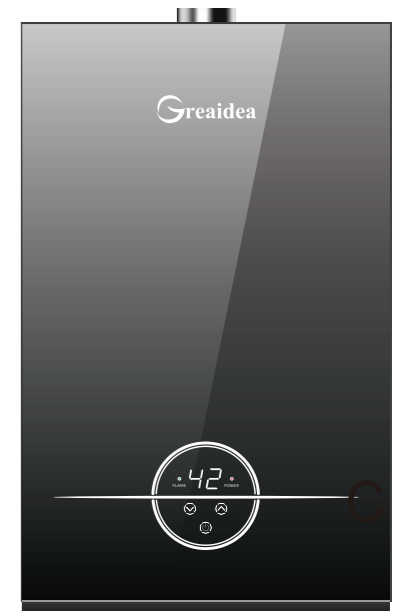

JSC*-G3
(Glass Panel)

Rated Water Output($\Delta t=25^{\circ}\text{C}$)L/Min	12L/min	16L/min
Rated Thermal Load	24KW	30KW
Product Size(MM)	560x350x140	560x350x140
Package Size(MM)	685x405x215	685x405x215
Loading Qty.(PCS)20FT/40FT/40HQ	380/760/900	380/760/900

Remark: Unit and its Pipe packed separately.



High-end Model

- White light LED display with battery power indicator
- European style panel
- European style chimney
- Oxygen free copper heat exchanger
- Heating Capacity: 8L / 10L / 12L
- With Anti-block protection



Mid-end Model

- White light LED display
- Chinese style panel
- European style chimney
- Tin-coated copper heat exchanger
- Heating Capacity: 8L / 10L / 12L
- With Anti-block protection



Eco-end Model

- Chinese style panel
- Chinese style chimney
- Tin-coated copper heat exchanger
- Heating Capacity: 8L / 10L / 12L
- With Anti-block protection

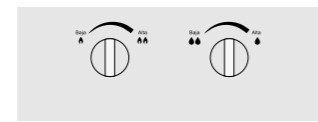

Model Comparison

	High-end Model	Mid-end Model	Eco-end Model
Top View			
Front View			
Bottom View			
Inside View	 Oxygen-free copper Heat Exchanger	 Tin-Coated copper Heat Exchanger	 Tin-Coated copper Heat Exchanger

	High-end Model	Mid-end Model	Eco-end Model
Rated Water Output($\Delta t=25^{\circ}\text{C}$)L/Min	8L/min	10L/min	12L/min
Product Size(MM)	520x320x170	550x340x180	590x340x180
Package Size(MM)	635x375x210	675x390x235	705x390x235
Loading Qty.(PCS)20GP/40HQ	559 / 1359	452 / 1099	433 / 1052



EU Low NO_x GAS WATER HEATER

Since Sept. 26, 2018, all gas heaters placed on the European market for the first time must have emissions below 56 mg/kWh. This new generation of Low NO_x heaters achieves a level well below what is established by the regulations.



JSD22-M1LP
JSD22-M1GN

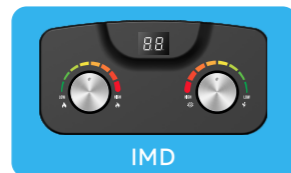

IMD



JSD22-D3LP
JSD22-D3GN

- With ERP certificate: **A**
- Atmospheric gas water heater of 11L/min
- Low NO_x emissions
- Ignition by batteries. Automatic flammulation
- Available for natural gas, propane and butane
- No pilot light: more gas savings
- Variable and modulating power
- White LED digital display

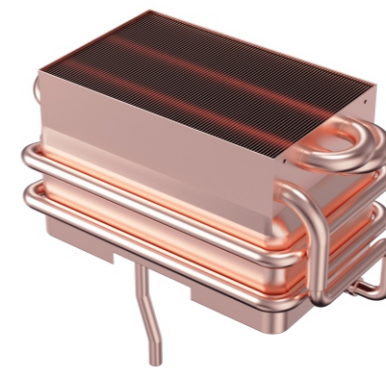

Oxygen-free Copper Heat Exchanger

The oxidation treatment of the oxygen-free copper heat exchanger can prevent the heat exchanger from oxidation or corrosion in the course of use, and has high thermal conductivity and long service life.

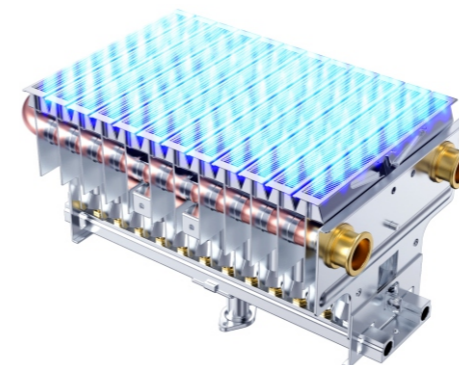

Cooled Burner (Cool System)

Exclusive cooled burner, specifically designed and built to be able to cool the flame base throughout its entire path, thus drastically reducing NO_x emissions into the atmosphere, maximizing its performance.

Patent No. CN 107787429 A



JSD22-D2LP
JSD22-D2GN



JSD22-D1LP
JSD22-D1GN



JSD22-D5LP
JSD22-D5GN



JSD22-D4LP
JSD22-D4GN



JSD22-B1LP
JSD22-B1GN



JSD22-B2LP
JSD22-B2GN

MODELS-11L	JSD22-B1	JSD22-B2	JSD22-D1	JSD22-D2
	JSD22-D3	JSD22-M1	JSD22-M2	JSD22-M3
Gas categories	LPG		GN	
Nominal heat flow rate(Max/Min,kw)	22/8.5		22/8.5	
Gas type	G30/G31		G20/G25	
Gas pressure (mbar)	29/37		20/25	
Hot water capacity ($\Delta t=25^{\circ}$ C,L/min)	11		11	
Net weight (kg)	11		10	
Power supply	Batteries(DC 3V)		Batteries(DC 3V)	
Product Dimension	610x340x180 MM		550x340x180 MM	
Packing Dimension	395x235x710 MM		705x395x235 MM	
Loading Quantity (20GP/40GP/40HQ)	420/870/1020		420/870/1020	



RV Tankless Water Heater

with 15 x 15 inches
Black Door / White Door



Camping Water Heater (5.5/6.5/8L)



- ★ Flameout protection
- ★ Overheating protection
- ★ Anti-dry-burn protection
- ★ Water over pressure protection
- ★ Anti-backdraft protection

BTU	55,000 BTU	Maximum Flow Rate	2.1 GPM
Fuel	Propane (LP Gas)2800Pa	Water Operating Pressure	MAX=60 PSI
Power Input	12V DC	Setting Temperature Range	95F(35C)-123°F(51C)
Ignition Type	Auto-ignition	Net Weight/Gross Weight	241b/281b
Power Input	35W		