



GROW ROOM DEHUMIDIFIER
SDT-150L

INSTRUCTION MANUAL

3rd-party controller ready



Thank you for purchasing this dehumidifier.

WARNING • Before using, read this instruction manual of this dehumidifier to ensure correct usage through understanding. After reading, store them in a safe place for future reference. Incorrect handling of this product could possibly result in personal injury or physical damage.



Exclusively grow room designed dehumidifiers

1. All metal plate framed structure shell.
2. Separated electrical box for easily maintaining.
3. Low voltage control.
4. Opposite air inlet and outlet to reduce efficiency interference.
5. Duct kits as optional accessories can be easily connected.
6. Long-life brushless direct drive fan.Noise 50% lower.
7. Memory function of operating mode after power outages.
8. High efficiency rotary compressor.

DIRECTORY

SAFTY INSTRUCTIONS ----- 4

SPECIFICATIONS ----- 5

UNPACKING THE DEHUMIDIFIER ----- 6

INSTALLATION GUIDE ----- 8

OPERATION GUIDE ----- 10

EXTERNAL CONTROLLER----- 12

NORMAL MALFUNCTION REMOVAL ----- 14

SAFTY INSTRUCTIONS

WARNING

1. 208-240 volts may cause serious injury from electric shock. Disconnect electrical power before starting installation or servicing. Leave power disconnected until installation/service is completed.
2. Don't roll or damage the power cord when install or move the machine
3. Don't put finger or any other rod like object into the machine

CAUTION

1. Do not tilt the machine more than 45 ° in moving or installation to avoid damage to the compressor.
2. Working temperature scope of the machine is 5 °C ~ 38 °C.
3. The room temperature will go up around 3 °C from compressor heat dissipation when dehumidifier running, it's normal phenomenon, please feel free to use.
4. It's not necessary to use dehumidifier when the room temperature is below 10 °C, the absolute humidity is quite low at this condition.
5. Please try to seal environment better to increase the effect of dehumidifier.
6. Do not place the machine in the area which may come into contact with water or chemical.
7. Do not use any relay, extension line or adapter to connect the power of machine.
8. Do not place the machine next to the stove, heater and other equipment will dissipate heat, and area with direct sunlight or wind and rain.
9. Do place the plug stably and clean the dust on power line.
10. Do not damage or modify the power line, do not repair by yourself and disassemble or modify the machine.
11. Do place the drainage tube smoothly for continuously drain.
12. Shutdown the equipment and cut power when in malfunction.

SPECIFICATIONS

ENVIRONMENTAL	
Operating Temperature Range	40° F - 100° F
Operating Humidity Range	RH40% - RH95%
MECHANICAL	
Weight	134 lbs (without packaging)
Drain Size	5/8"
Capacity	320 Pints @ 86° F, 80% RH
Airflow	790 CFM (free flow)
ELECTRICAL	
Voltage	208~230 VAC ~, 1 ϕ , 60 HZ
Operating Current	7.0A @ 86° F, 80% RH
Efficiency (@ 86° F, 80% RH)	5.2 L/kW-hr (11.1 pints/kW-hr) @ 86° F, 80% RH
Efficiency (@ 80° F, 60% RH)	3.13 L/kW-hr (6.67 pints/kW-hr) @ 80° F, 60% RH

DIMENSIONS

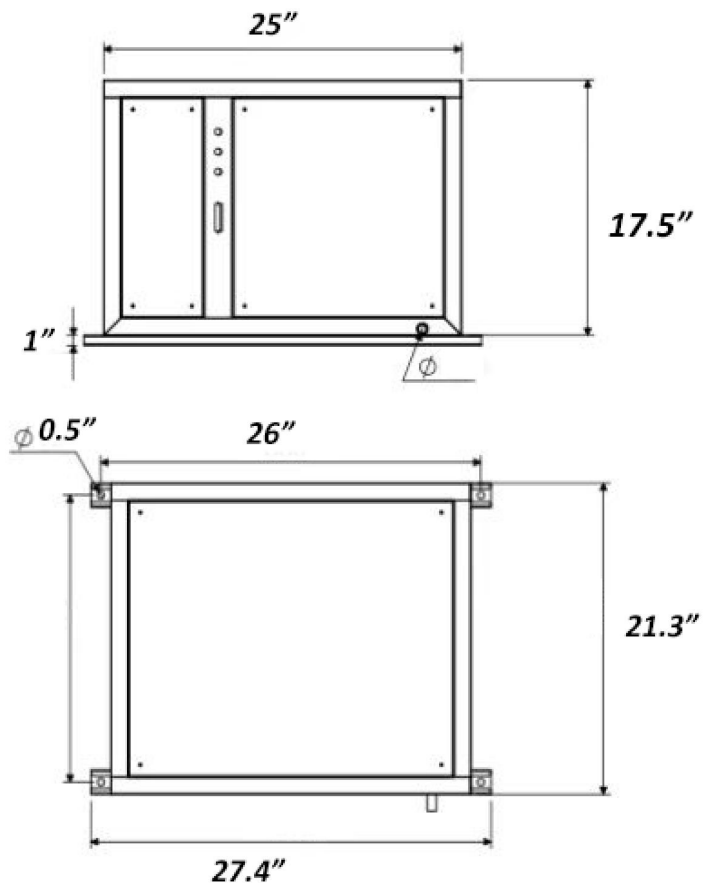

UNPACKING THE DEHUMIDIFIER

Unpack the outer wooden case, and remove the protection film to take out the dehumidifier for installation.

STRUCTURE AND RUNNING

WHAT'S IN THE CASE

Dehumidifier/controller/Drain tube / Filter /Instruction manual
Power cord /Technical label

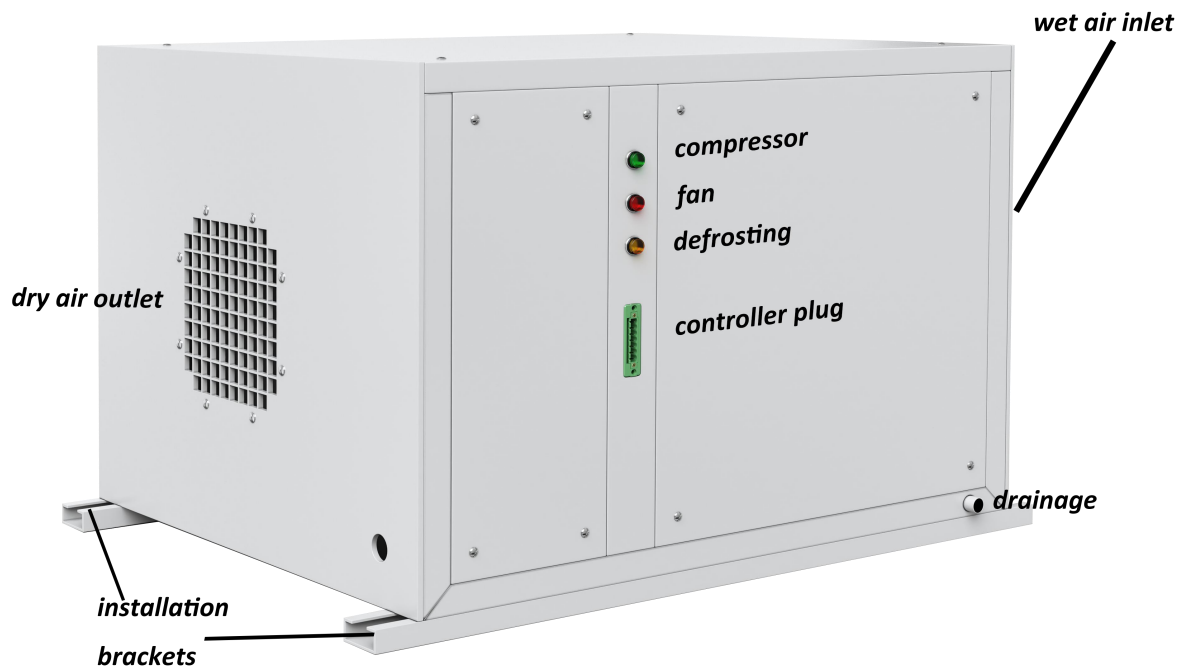

Operation mode lights

There are 3 LED lights stands for different operating mode.



The green light stands for compressor operating mode.



The red light stands for fan operating mode.



The yellow light stands for defrosting mode.

Automatic defrost protection function

The dehumidifier will defrost automatically when freezing occurs. While defrosting, the compressor will not work but the brushless fan will continue to run in order to melt the ice on coil inside. Defrosting light will be on. Dehumidifier will start automatically once defrost process is complete.

Default defrost setting occurs when ambient temperature is under 15°C

Compressor delay start protection function

Manual restart of system within 3 minutes of shutdown, the compressor will start up within 3 minutes of delay protection.

INSTALLATION GUIDE

PREPARING BEFORE INSTALLATION

- A. Do disconnect the plug from power outlet to ensure safety.
- B. Make sure the power and drain tunnel
- C. Prepare necessary tools like screwdriver, thread rod, spanner etc.

START INSTALLATION

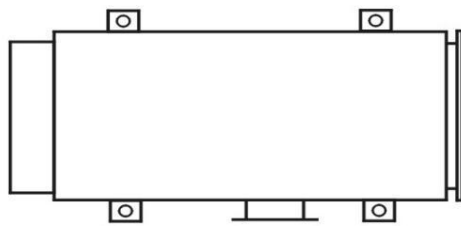

TOP VIEW

- A. Drill four fixing holes on the ceiling according to the position of install hole on the machine, then install the expansion screw to fix the thread rod.

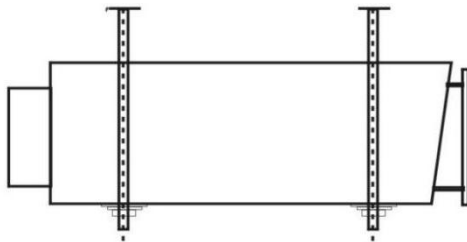

SIDE VIEW

- B. Install dehumidifier through the four thread rods, and adjust the height according the space to ensure the machine on horizontal level.
- C. Connect the drain tube to make sure no leakage, no block in the drainage tube.
- D. Connect power, please make sure the power supply is 208~240v/60hz. And the overload air break switch should be used.

CAUTION IN INSTALLATION

1. Ensure necessary safety measures to avoid incident, **electrical must be shut off during the installation process.**
2. Use the strength four thread rods with corresponding screws to fix the dehumidifier on the ceiling.
3. Ensure the installation of dehumidifier is horizontal to avoid malfunction or leakage.
4. Ensure drain tube is installed unhindered without overmuch bends.
5. Ensure dehumidifier is installed within space with proper air circulation for air inlet and air outlet, it is prohibited to install at corner or space with obstructions what block the inlet or outlet.

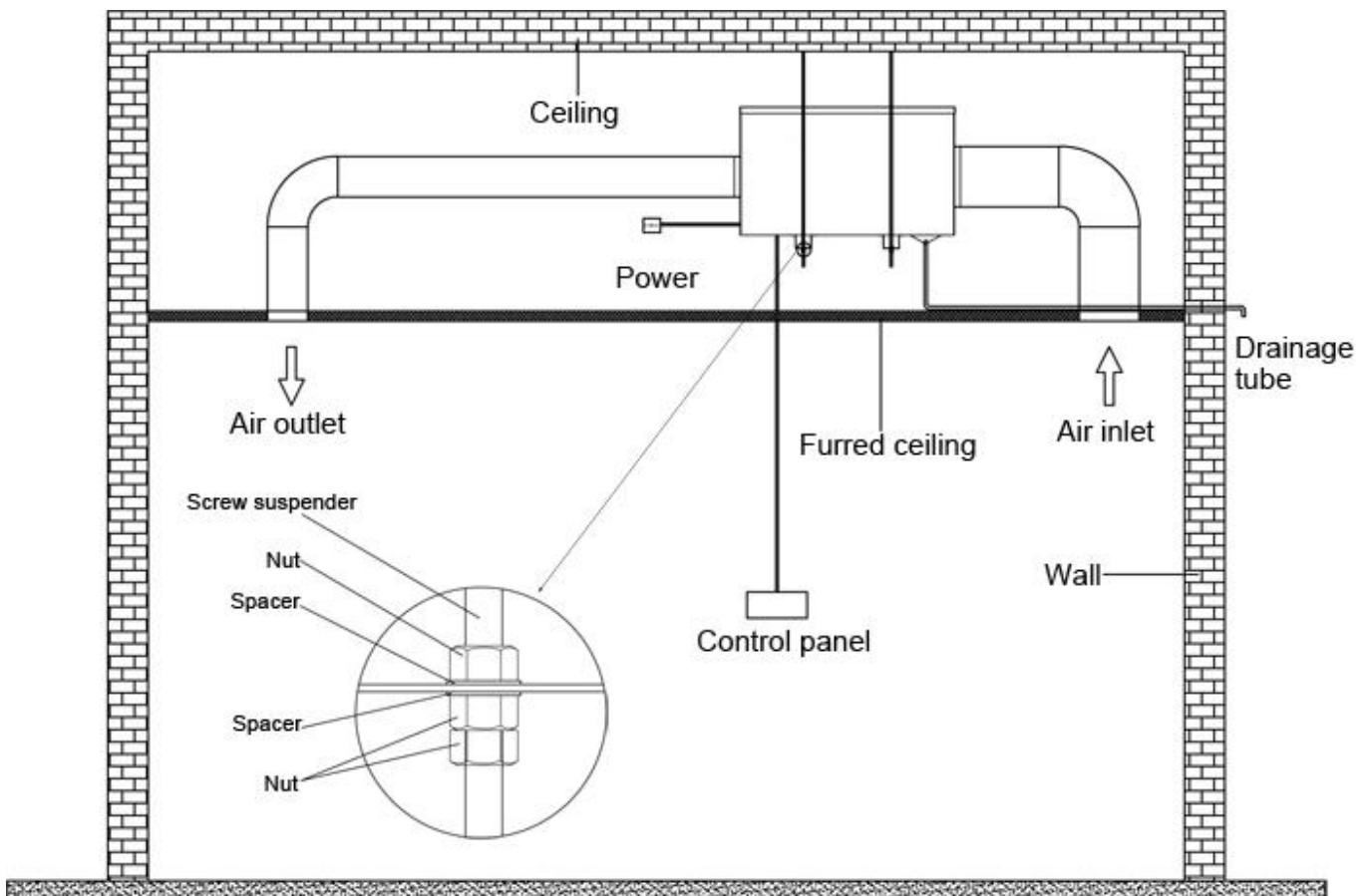

OPERATION GUIDE

Connect controller to the terminal on the machine, then connect the power cord with power supply and make sure it is 208-240v single phase 60hz. Turn power supply on to start the machine.

DAILY MAINTENANCE

1. Do shut down the power supply before maintenance.
2. Wipe the body with soft cloth in daily use. Use a wet hard cloth to wipe dirty body, or use a soft cloth moistened with a little diluted neutral detergent.
3. Filter Cleaning: it will affect the dehumidifying effect or cause malfunction if accumulate dust on filter , it needs to be cleaned regularly, clean it at least once a month. Use dust catcher to remove dust or put filter into clean water (<40 °C) to wash, then place filter back after cleaning.

NOTE: The filter cannot be put in sunlight directly or roasted to avoid distortion. The filter must be placed before power up machine.

4. Non use of equipment :Cut the power or unplug power line. Place equipment in dry and shaded area.

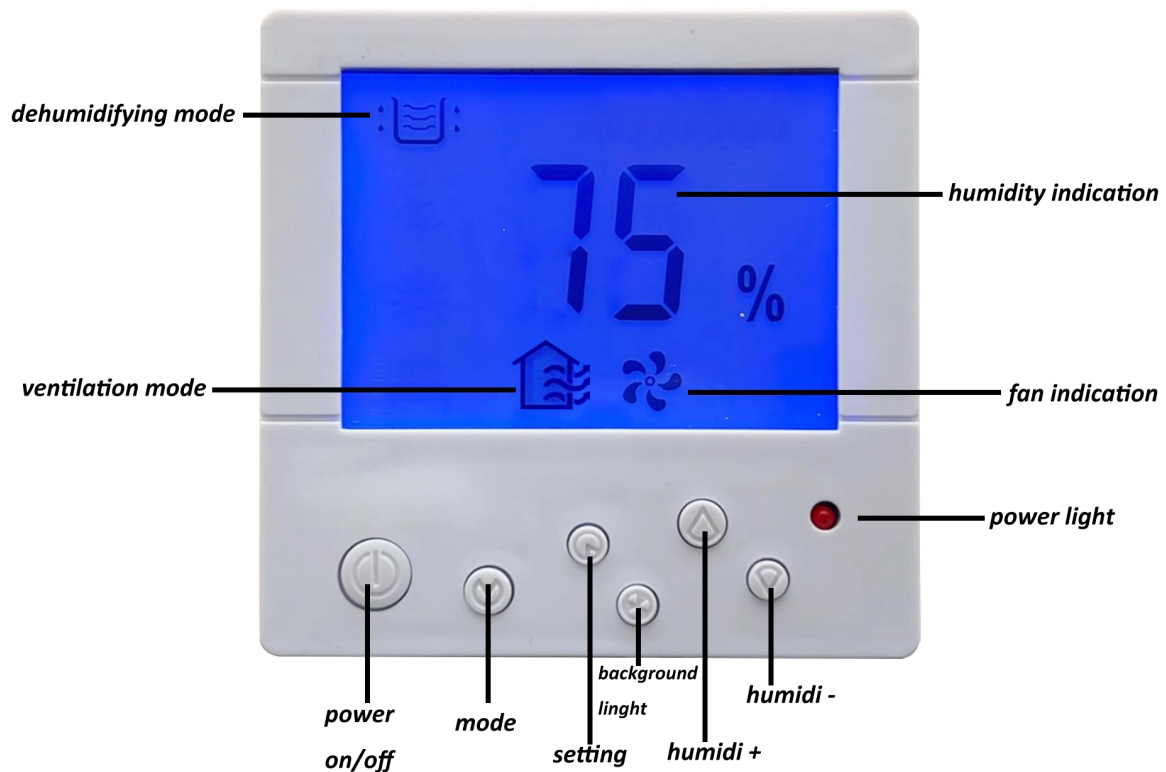

1. The screen will display ambient humidity when plug in power.
2. Press “Power on/off” button to start the dehumidifier. “power light” will on.
3. In the dehumidifying mode
Press “Setting” button to set target RH%.
After pressing “setting”, press the “humidi +” and “humidi -” to set the target humidity. The “humidity indication” will blink on the LCD when in humidity setting mode.
4. The LCD will display Current ambient humidity when in standby or dehumidifying mode. Setting mode will automatically become to dehumidifying mode after 5 seconds without pressing any button.
5. The “dehumidifying mode” symbol will on when compressor is working.
The “dehumidifying mode” symbol will blink if the compressor in 3 minutes delay protection.
6. Press “mode” button to switch ventilation mode if you want only fan to run. The “ventilation mode” symbol will on.

 (Note, frequent restarting dehumidifier will be harmful to compressor. In this case the 3 minutes compressor delay protection will be an essential part of the machine.)

EXTERNAL CONTROLLER

Definition of external plug

The dehumidifier provides 6 pin plug for external controller.

1 = spare

2 = spare

3 = dehumidification for both fan and compressor control

4 = +24V power

5 = fan control

6 = -24v power. Common

The 4 and 6 terminal will provide 24V DC with 40VA. This 24V DC power source can be used for both 24V DC and AC controller.

Controller SDT-24DA is provided with dehumidifier

SDT-24DA wiring

SDT-24DA CONTROLLER

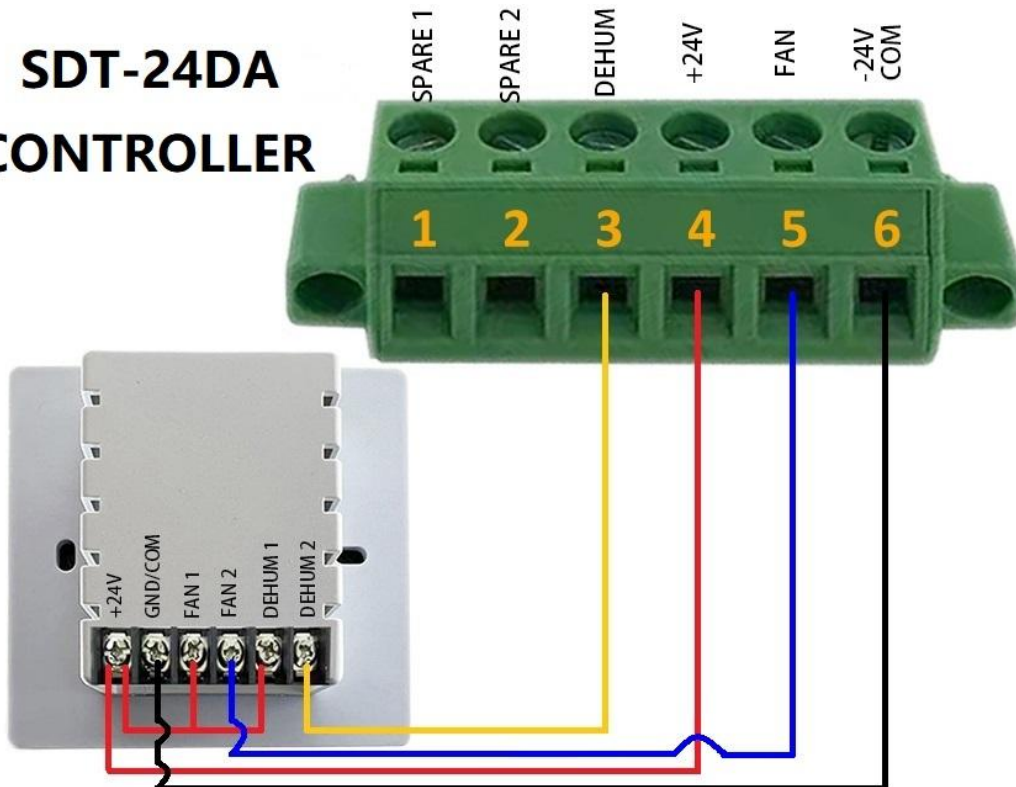

HS-1 wiring

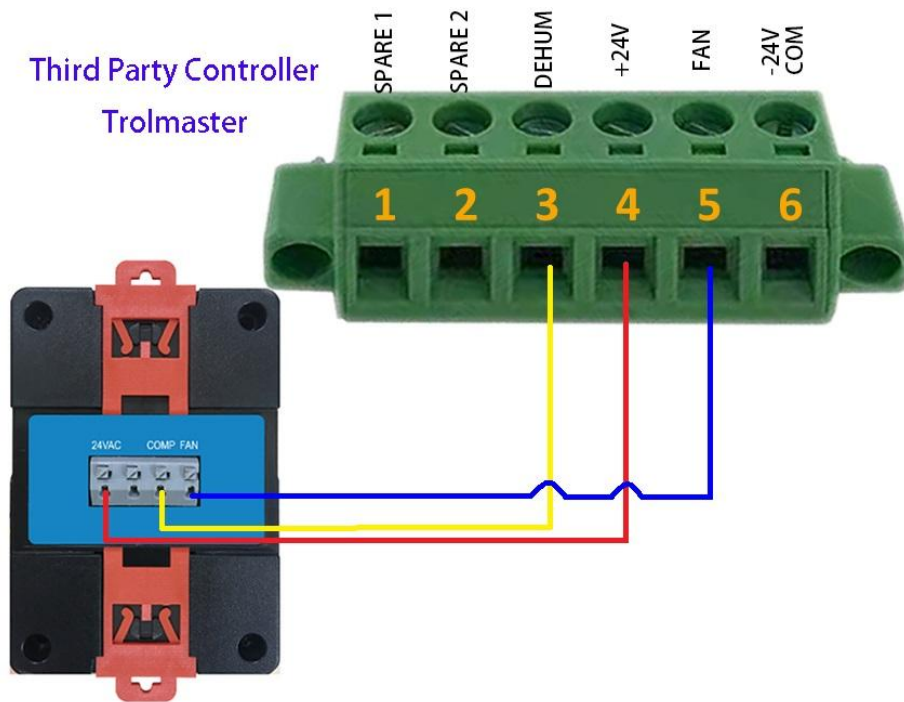

Other 3rd party controller wiring

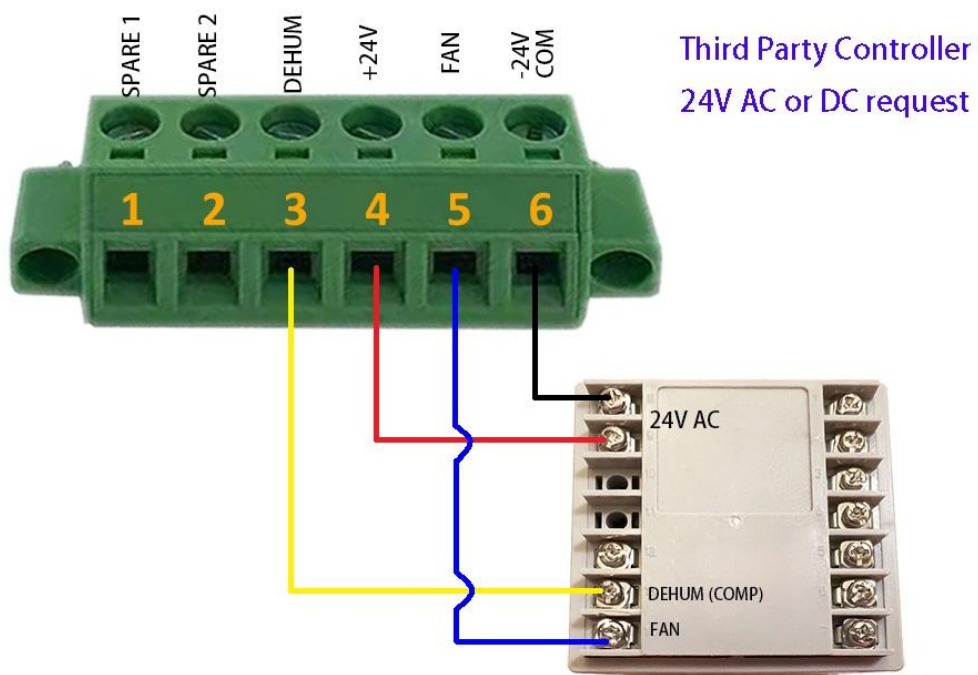

NORMA MALFUNCTION REMOVAL

MALFUNCTIONS	ANALYZE	REMOVAL
DEHUMIDIFIER IS NOT WORKING	<ol style="list-style-type: none"> 1. POWER FAILURE 2. POWER OFF 3. POWER IS NOT PLUG IN 4. BLOWN FUSE 	<ol style="list-style-type: none"> 1. RESUME POWER 2. POWER ON 3. PLUG IN 4. REPLACE FUSE
BAD DEHUMIDIFICATION EFFECT	<ol style="list-style-type: none"> 1. FILTER BLOCKED WITH DUST 2. AIR INLET IS BLOCKED 3. USED IN BAD SEALED ROOM 4. LESS REFRIGERANT 	<ol style="list-style-type: none"> 1. WASH FILTER 2. REMOVE BLOCK 3. CLOSE DOOR AND WINDOW 4. FILL REFRIGERANT OR CONTACT WITH MANUFACTURER
LEAKAGE	<ol style="list-style-type: none"> 1. MACHINE IS NOT HORIZONTAL 2. DRAIN TUBE IS BLOCKED 	<ol style="list-style-type: none"> 1. PLACE THE MACHINE HORIZONTAL 2. WASH OR CHANGE THE TUBE
NOISE	<ol style="list-style-type: none"> 1. MACHINE IS NOT INSTALLED STABLE 2. FILTER BLOCKED 	<ol style="list-style-type: none"> 1. PLACE THE MACHINE STABLE 2. WASH THE FILTER

REMARKS

1. Please contact manufacturer or agent to maintain the malfunction that cannot be confirmed and removed, don't disassemble the machine by yourself
2. It will produce noise when the dehumidifier power on or power off, it's normal.
3. It will produce heat wind at the air outlet, it's normal



EAST dehumidifier manufacturer

Room 1603-1604, Yifeng Times Mansion, Hangzhou, China 311113

Phone: +8613685770742

WhatsApp: +8613685770742

Skype: tiger19840517

<https://www.eastdehumidifier.com>