

## GCZ20-5011D 20-50mm f/1.1 Continuous Zoom Infrared Lens

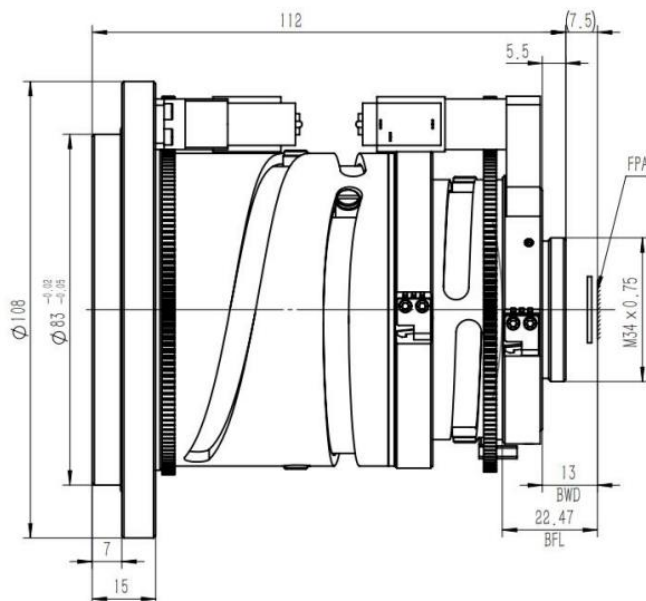

HFOV	160x120	320x240	336x256	384x288	640x480	640x512
25 $\mu$ m	4.6°-11.4°	9.1°-22.6°	9.6°-23.7°	11°-27°		
17 $\mu$ m	3.1°-7.8°	6.2°-15.5°	6.5°-16.3°	7.5°-18.5°	12.4°-30.4°	12.4°-30.4°
12 $\mu$ m	2.2°-5.5°	4.4°-11°	4.6°-11.5°	5.3°-13.1°	8.8°-21.7°	8.8°-21.7°

### Optical

Focal Length(mm)	20-50
F/#	1.1
Wavelength	8-12 $\mu$ m
Focus Range	1.5m-Infinity/3m-Infinity

### Mechanical

Interface	Flange
Focus Mechanism	Motorized
Dimensions (mm)	$\varnothing 108 \times 112$ mm
Weight	800g

### Electrical & Communications

Power Input	DC 12V Average
-------------	----------------

### Environmental

Operating Temperature	-40°C to +60°C
Storage Temperature	-50°C to +70°C
Front Element Sealing	IP67
External Coating	DLC