

GCZ32512ZFK 25-75mm f/1.0-1.2 Continuous Zoom Infrared Lens

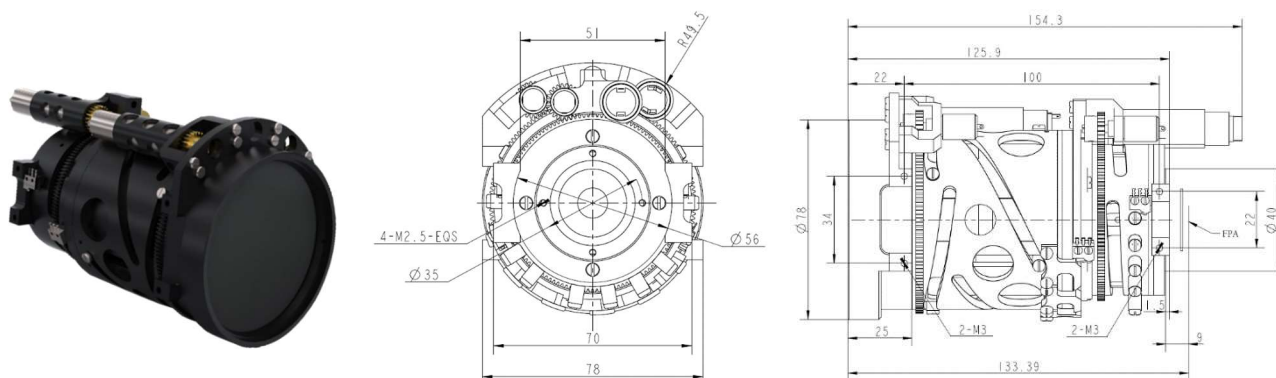

HFOV	160x120	320x240	336x256	384x288	640x480	640x512	1024x768	1280x1024
25μm	3.1°-9.1°	6.1°-18.2°	6.4°-19.1°	7.3°-21.7°				
17μm	2.1°-6.2°	4.2°-12.4°	4.4°-13°	5°-14.9°	8.3°-24.6°	8.3°-24.6°		
14μm							10.9°-32°	
12μm	1.5°-4.4°	2.9°-8.8°	3.1°-9.2°	3.5°-10.5°	5.9°-17.5°	5.9°-17.5°	9.4°-27.6°	

Optical

Focal Length(mm)	25-75
F/#	1.0-1.2
Wavelength	8-12μm
Focus Range	10m-Infinity

Mechanical

Interface	Flange
Focus Mechanism	Motorized
Dimensions (mm)	Ø78x124.39
Weight	900g

Electrical & Communications

Power Input	DC 12V
Communications	NA

Environmental

Operating Temperature	-40°C to +60°C
Storage Temperature	-45°C to +65°C
Front Element Sealing	IP67
External Coating	DLC