

Laser Range Finder Technical Instruction

LSR10A-1035

1 Summarize

The laser rangefinder is a safety laser rangefinder in the pod photoelectric system, which can detect the target distance and transmit the measured distance to the host computer through serial communication.

2 Structural composition and main functional indicators

The laser rangefinder consists of laser, transmitting optical system, receiving optical system and control circuit. The main performance is as follows:

2.1 Working distance

Under normal conditions, visibility should not be less than 15km, for 2.3m×2.3m targets, diffuse reflectance ≥ 0.3 , humidity $\leq 80\%$, ranging distance ≥ 6 km, for buildings and other large targets ranging distance ≥ 8 km, minimum ranging is 50m.

2.2 Main function

The main functions of laser rangefinder are:

- A) Single ranging and continuous ranging;
- B) Distance gating and target indication before and after;
- C) Self-check function.

2.3 Performance

- A) wavelength: 1535nm
- B) Laser divergence Angle: ≤ 0.4 mrad
- D) Continuous ranging frequency: adjustable from 1Hz to 10Hz
- E) Ranging accuracy: $\leq \pm 2$ m (RMS)
- F) Accuracy rate: $\geq 98\%$
- G) Ranging resolution: ≤ 50 m
- H) Power supply voltage: 9~36VDC
- I) Weight: ≤ 120 g
- J) Power: average power consumption ≤ 1.5 W, peak power consumption ≤ 5 W

K) Size: $\leq 70.5 \times 60 \times 46 \text{mm}$

L) Operating temperature: $-40^{\circ}\text{C} \sim +60^{\circ}\text{C}$

M) Storage temperature: $-45^{\circ}\text{C} \sim +70^{\circ}\text{C}$

2.4 Interface specification

Communication interface: RS422, 115200bps

Electrical interface: The interface model. The interface definition is detailed in the table below

8Pin Socket connection Definition

Number	Definition	Color	Remarks
1	RS422 RX+	Brown	RS422 Receive data +
2	RS422 RX-	Blue	RS422 Receive data-
3	RS422 TX-	Yellow	RS422 Transmit data-
4	RS422 TX+	Purple	RS422 Transmit data +
5	GND	White	Communication interface ground connection
6	+12V	Red	Power+
7	GND	Black	Power ground
8	Null	Green	Null

Electrical isolation: power ground line, communication interface ground line, electrical isolation between shells.

2.5 Size

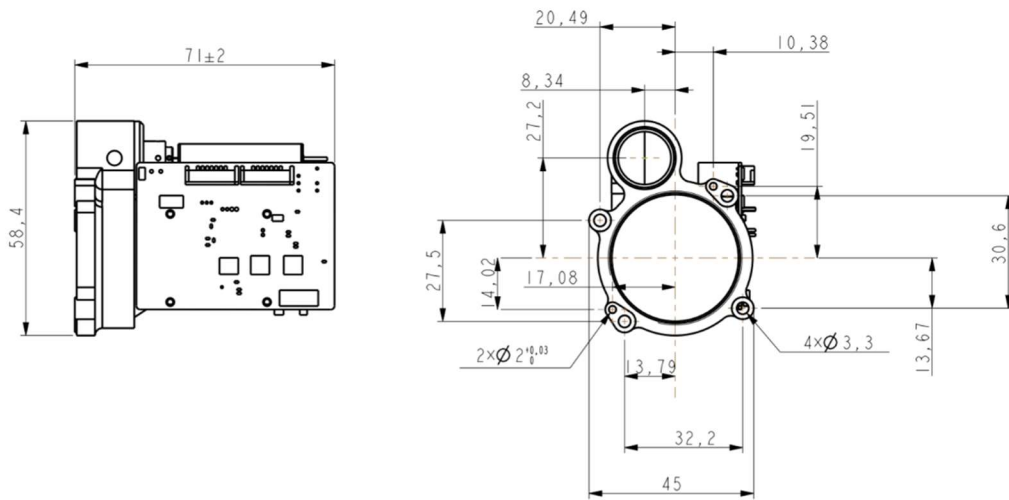

3 Matters needing attention

- The laser wavelength by the rangefinder is 1535nm, which is safe for human eyes. Although the wavelength is safe for human eyes, it is recommended not to look directly at the laser.
- When adjusting the parallelism of optical axis, the receiving lens must be blocked, otherwise the detector will be permanently damaged due to excessive echo.
- Costing the ranging module is non-airtight, ensure that the relative humidity of the environment is less than 80%, and ensure that the environment is clean and hygienic to avoid damaging the rangefinder.
- The rangefinder's range is linked to atmospheric visibility and the nature of the target, reducing the range when there is fog, rain and sand. Green leaf clusters, white walls, exposed limestone and other targets have good reflectivity and can increase the range. In addition, when the inclination Angle of the laser beam increases, the measuring range will be reduced.
- According to the principle, it is strictly forbidden to shoot laser at strong reflection targets such as glass and white wall within 50 meters, lest the echo is so strong that the APD detector is damaged.
- It is forbidden to plug and unplug the cable when it is energized.
- Ensure that the polarity of the power supply is connected correctly, otherwise the device can be permanently damaged.