

GMZ2015Z4A 15-300mm f/4.0 MWIR Continuous Zoom Infrared Lens

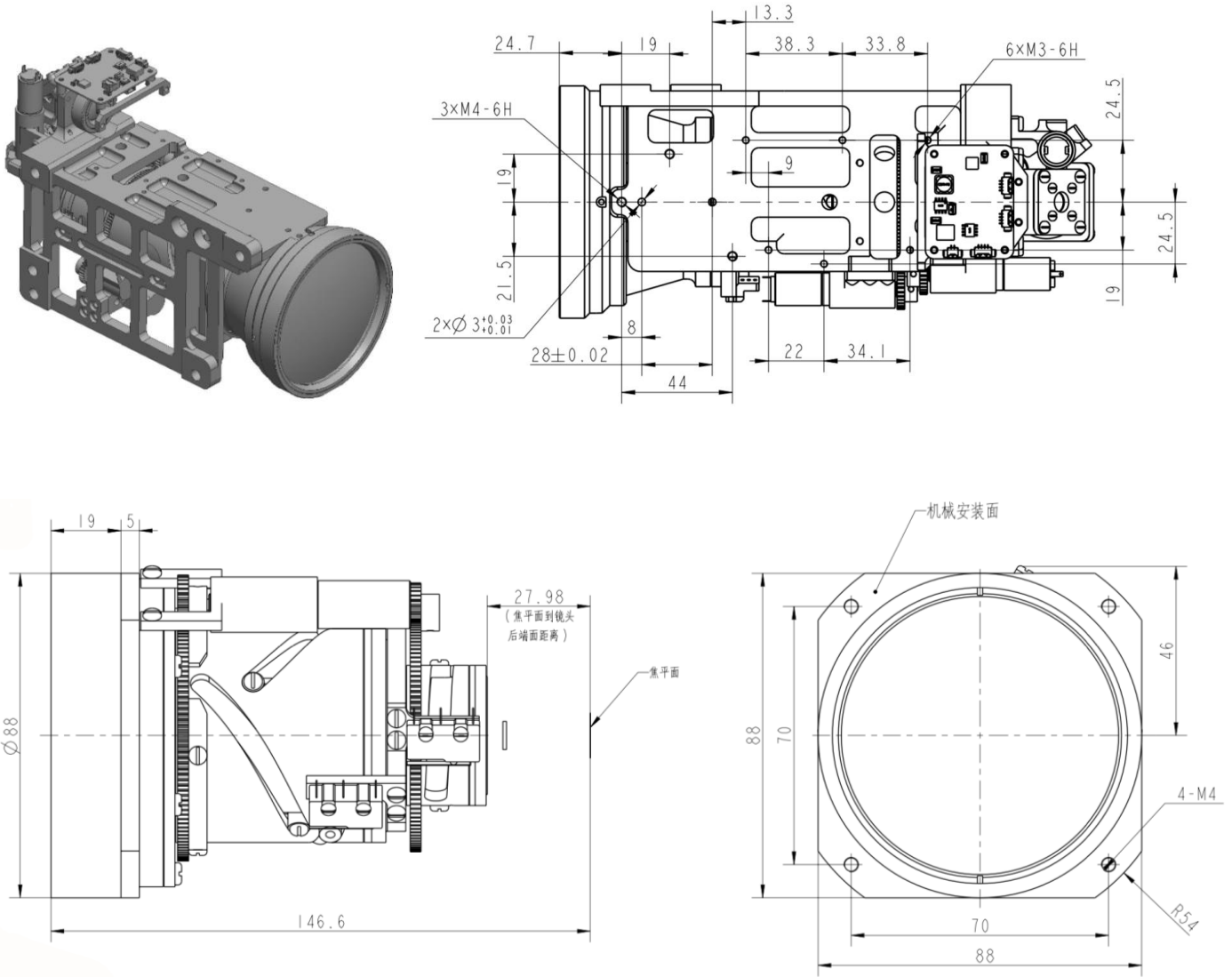

HFOV	160x120	320x240	336x256	384x288	640x480	640x512	1024x768	1280x1024
17μm	0.5°-10.4°	1°-20.6°	1.1°-21.6°	1.2°-24.6°	2.1°-39.9°	2.1°-39.9°		
15μm	0.5°-9.1°	0.9°-18.2°	1°-19.1°	1.1°-21.7°	1.8°-35.5°	1.8°-35.5°		
12μm	0.4°-7.3°	0.7°-14.6°	0.8°-15.3°	0.9°-17.5°	1.5°-28.7°	1.5°-28.7°		

Optical

Focal Length(mm)	15 - 300
F/#	4.0
Wave Length	3.7 – 4.8 μ m
Detector	640x512 15 μ m

Mechanical

Interface	Flange
Focus Mechanism	Motorized
Dimensions (mm)	Ø88x 146.6
Weight (grams)	≤780g

Electrical & Communications

Power Input	DC12V
Communications	NA

Environmental

Operating Temperature	-40°C to +60°C
Storage Temperature	-40°C to +80°C
Front Lens Sealing	IP67
External Coating	AR