

GCZ53012D 30-150mm f/0.85-1.2 Continuous Zoom Infrared

Lens

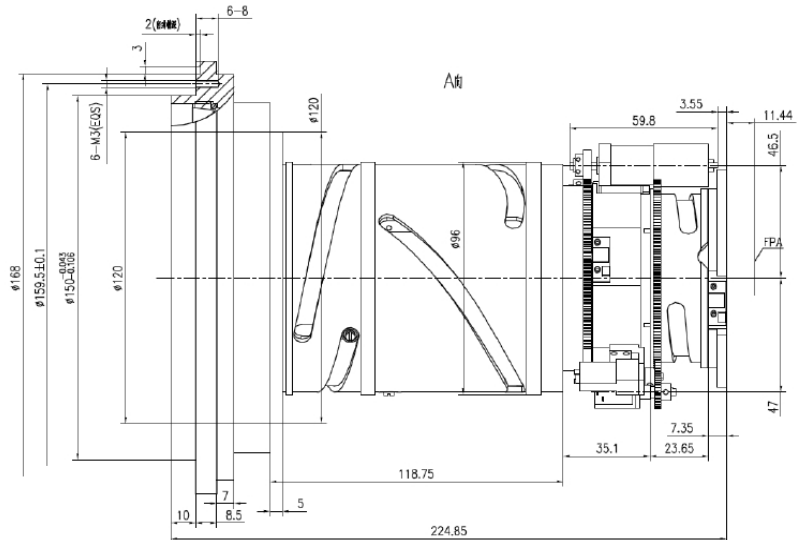

HFOV	160x120	320x240	336x256	384x288	640x480	640x512	1024x768	1280x1024
25μm	1.5°-7.6°	3.1°-15.2°	3.2°-15.9°	3.7°-18.2°				
17μm	1°-5.2°	2.1°-10.4°	2.2°-10.9°	2.5°-12.4°	4.2°-20.6°	4.2°-20.6°		
12μm	0.7°-3.7°	1.5°-7.3°	1.5°-7.7°	1.8°-8.8°	2.9°-14.6°	2.9°-14.6°		

Optical

Focal Length(mm)	30-150
F/#	0.85-1.2
Average Transmission	≥80%
Focus Range	5m-Infinity
Detector	640x480 17μm

Mechanical

Interface	Flange
Focus Mechanism	Motorized
Dimensions (mm)	Ø168.0x 224.85
Weight	<3870g

Electrical & Communications

Power Input	DC 6-12V 0.2A
Communications	NA

Environmental

Operating Temperature	-40°C to +60°C
Storage Temperature	-40°C to +80°C
External Coating	DLC
Front Element Sealing	IP67

