

Dalia 50ml



Brimful Capacity **55 ± 2 ml**

Net Weight **200 ± 5 g**

Dimensions **L80.2 x W42.2 x H85.5 mm**

Neck Finish **FEA15**

Dalia 50ml

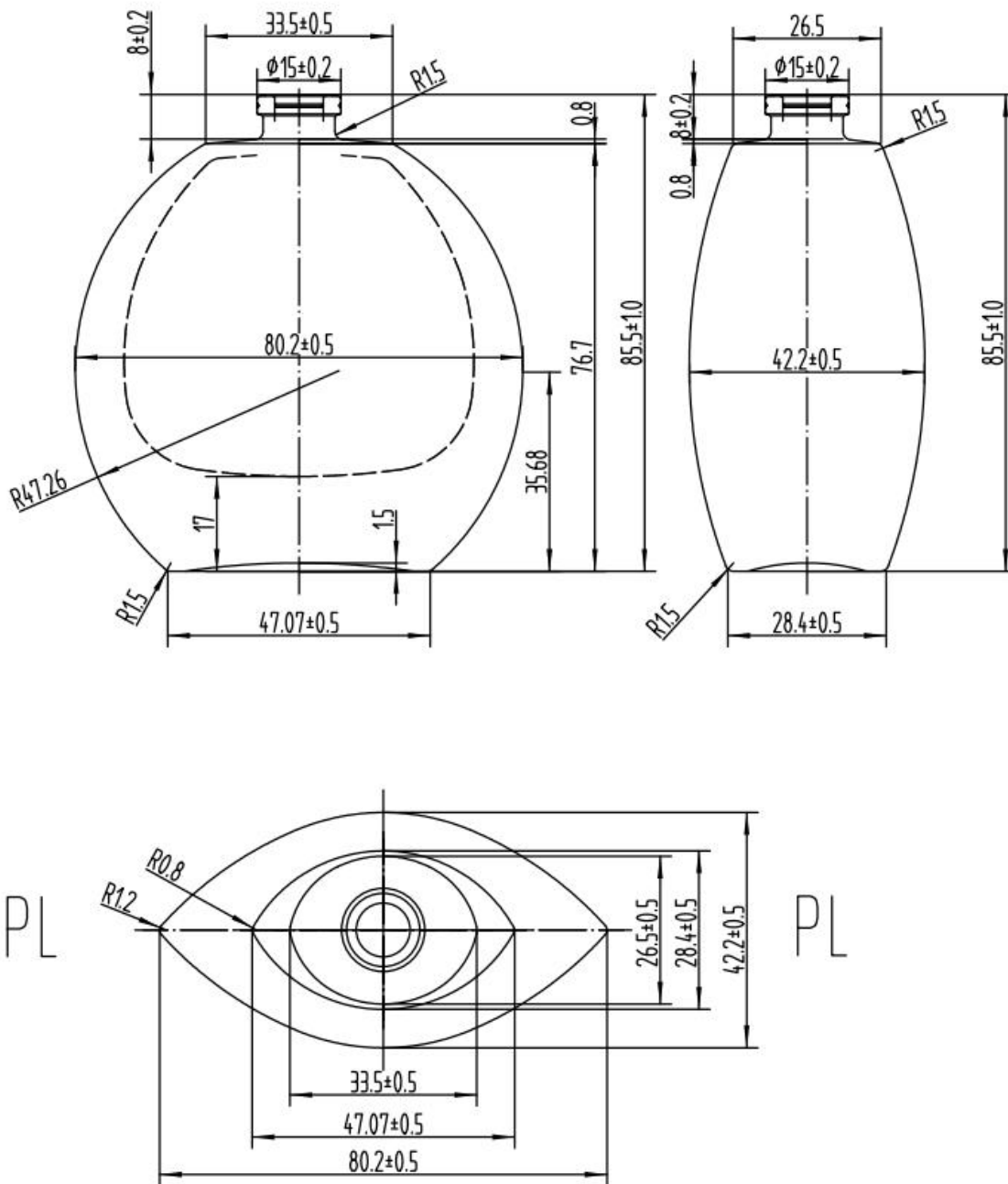

With integrated service of design, customization, wholesale, contract manufacturing, decoration, GP Bottles is providing bespoke perfume bottle packaging solutions for niche perfume brand.