

Botanicals 100ml



Brimful Capacity **108 ± 3 ml**

Net Weight **224 ± 5 g**

Dimensions **Dia.55.8 x H101.5 mm**

Neck Finish **FEA15**

Botanicals 100ml

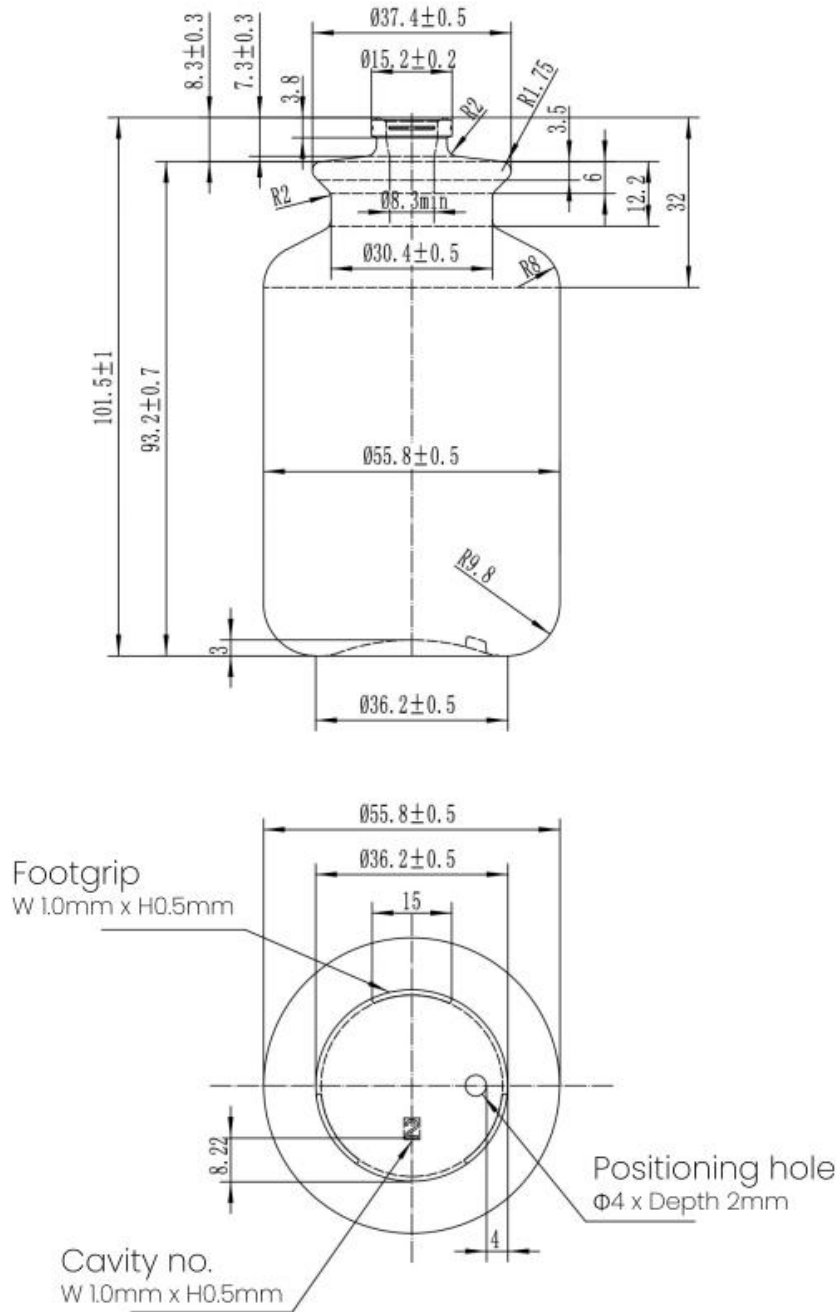

With integrated service of design, customization, wholesale, contract manufacturing, decoration, GP Bottles is providing bespoke perfume bottle packaging solutions for niche perfume brand.