

FV series conveyor chain

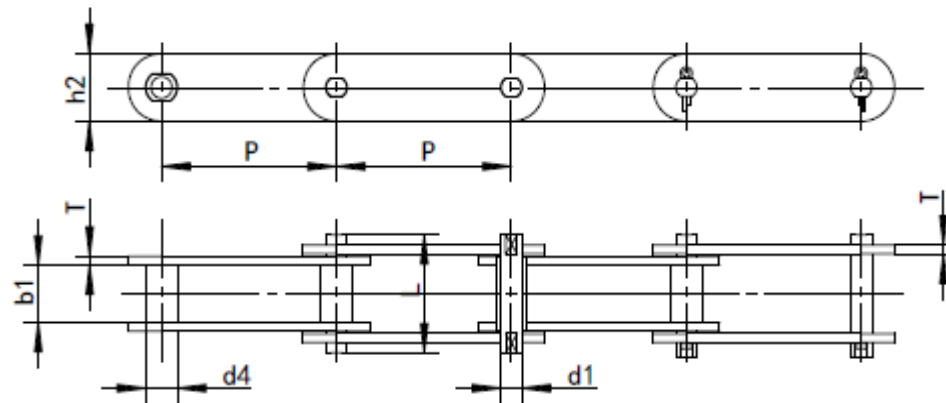

Without rollers

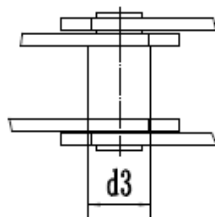

With S small rollers

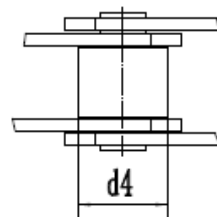

With P large rollers

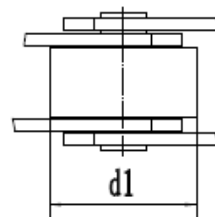

With F flanged rollers

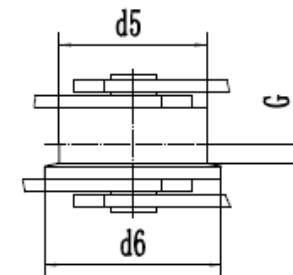

ZMIE Chain No.	Pitch							Roller diameter				Bush diameter
	P						d1 max	d4 max	d5 max	G	d3 max	
	mm						mm	mm	mm	mm	mm	
FV40	50.0	63.0	80.0	100.0	125.00	-	32.0	20.00	40.00	50	4.0	15.0
FV63	63.0	80.0	100.0	125.0	160.00	-	40.0	26.00	50.00	63	5.0	18.0

FV series conveyor chain

ZMIE Chain No.	Pitch						Roller diameter					Bush diameter
	P						d1 max	d4 max	d5 max		G	d3 max
	mm						mm	mm	mm		mm	mm
FV90	63.0	80.0	100.0	125.0	160.00	200.0	48.0	30.00	63.00	78	6.5	20.0
FV112	100.0	125.0	160.0	200.0	250.00	-	55.0	32.00	72.00	90	7.5	22.0
FV140	100.0	125.0	160.0	200.0	250.00	-	60.0	36.00	80.00	100	9.0	26.0
FV180	125.0	160.0	200.0	250.0	315.00	-	70.0	42.00	100.00	125	13.0	30.0
FV250	160.0	200.0	250.0	315.0	400.00	-	80.0	50.00	125.00	155	15.0	36.0
FV315	160.0	200.0	250.0	315.0	400.00	-	90.0	60.00	140.00	175	18.0	42.0

FV series conveyor chain

ZMIE Chain No.	Width between inner plates	Pin diameter	Pin length	Plate depth	Plate thickness	Ultimate tensile strength
	b1min	d2 max	L max	h2 max	T max	Q min
	mm	mm	mm	mm	mm	KN/LB
FV40	18.0	10.0	36.0	25.0	3.00	40/9000
FV63	22.0	12.0	45.0	30.0	4.00	63/14175
FV90	25.0	14.0	53.0	35.0	5.00	90/20250
FV112	30.0	16.0	62.0	40.0	6.00	112/25200
FV140	35.0	18.0	67.0	45.0	6.00	140/31500
FV180	45.0	20.0	86.0	50.0	8.00	180/40500
FV250	55.0	26.0	97.0	60.0	8.00	250/56250
FV315	65.0	30.0	113.0	70.0	10.00	315/70875

Attachments for FV series conveyor chain

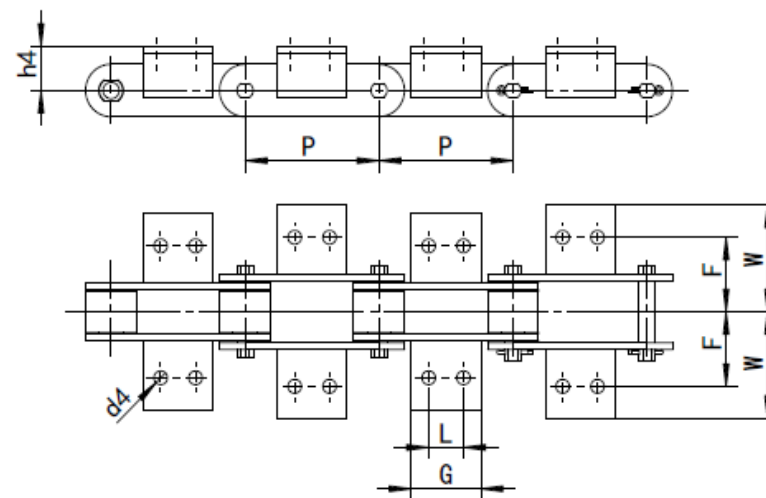
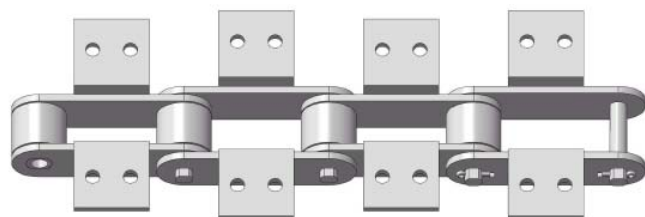

ZMIE Chain No.	P	L	G	d4	F	W	
	mm	mm	mm	mm	mm	mm	
FV40	50.00	△	45.00				
	63.00	△	31.00				
	80.00	25.00	45.00	6.50	25.00	40.50	20.00
	100.00	30.00	50.00				
FV63	125.00	30.00	60.00				
	63.00	△	40.00				
	80.00	25.00	45.00				
	100.00	30.00	50.00	8.40	34.00	50.00	30.00

	125.00	40.00	60.00				
	160.00	50.00	70.00				
	63.00	△	30.00				
	80.00	25.00	45.00				
FV90	100.00	30.00	50.00	8.40	40.00	64.00	35.00
	125.00	40.00	60.00				
	160.00	50.00	70.00				
	200.00	60.00	80.00				
	100.00	30.00	50.00				
	125.00	40.00	65.00				
FV112	160.00	50.00	75.00	11.00	50.00	70.00	40.00
	200.00	65.00	90.00				
	250.00	80.00	105.00				
	100.00	30.00	55.00				
	125.00	40.00	65.00				
FV140	160.00	50.00	75.00	11.00	50.00	81.00	45.00
	200.00	65.00	90.00				
	250.00	80.00	105.00				
	125.00	35.00	63.00				
	160.00	50.00	80.00				
FV180	200.00	65.00	95.00	13.00	64.00	91.00	45.00

	250.00	80.00	110.00				
	315.00	100.00	130.00				
	160.00	50.00	80.00				
	200.00	65.00	95.00				
FV250	250.00	80.00	110.00	14.00	69.00	106.00	55.00
	315.00	100.00	130.00				
	400.00	100.00	130.00				
	160.00	△	50.00				
	200.00	65.00	95.00				
FV315	250.00	80.00	110.00	14.00	85.00		60.00
	315.00	100.00	130.00				
	400.00	100.00	130.00				

△ The attachment with 1 hole only.

FVT series conveyor chain

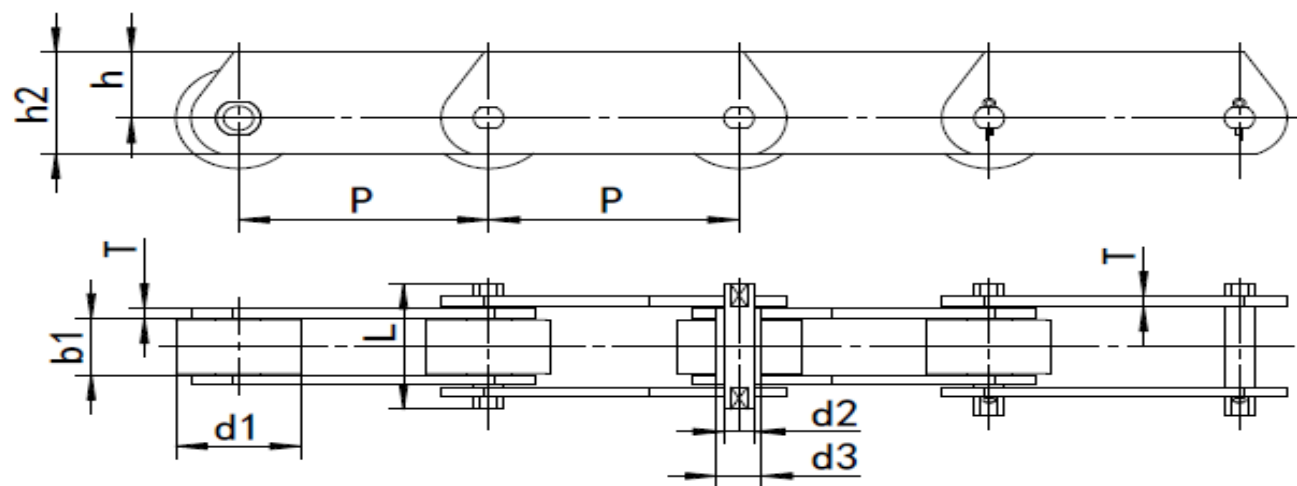

ZMIE Chain No.	Pitch					Width between inner plates	Roller diameter
	P					b1 min	d1 max
	mm					mm	mm
FVT40	50.0	63.0	80.0	100.0	125.00	18.0	32.0
FVT63	63.0	80.0	100.0	125.0	160.00	22.0	40.0
FVT90	63.0	80.0	100.0	125.0	160.00	25.0	48.0
FVT112	100.0	125.0	160.0	200.0	250.00	30.0	55.0
FVT140	100.0	125.0	160.0	200.0	250.00	35.0	60.0

FVT180	125.0	160.0	200.0	250.0	315.00	45.0	70.0
FVT250	160.0	200.0	250.0	315.0	-	55.0	80.0
FVT315	160.0	200.0	250.0	315.0	400.00	65.0	90.0
Bush diameter	Pin diameter	Pin length	Plate depth	Plate depth	Plate thickness	Ultimate tensile strength	
	d2max	L max	h2 max	h max	T max	Q min	
mm	mm	mm	mm	mm	mm	KN/LB	
15	10.0	36.0	35.0	22.5	3.00	40/9000	
18	12.0	45.0	40.0	25.0	4.00	63/14175	
20	14.0	53.0	45.0	27.5	5.00	90/20250	
22	16.0	62.0	50.0	30.0	6.00	112/25200	
25	18.0	67.0	60.0	37.5	6.00	140/31500	
30	20.0	86.0	70.0	45.0	8.00	180/40500	
36	26.0	97.0	80.0	50.0	8.00	250/56250	
42	30.0	113.0	90.0	55.0	10.00	315/70875	

FVC series conveyor chain

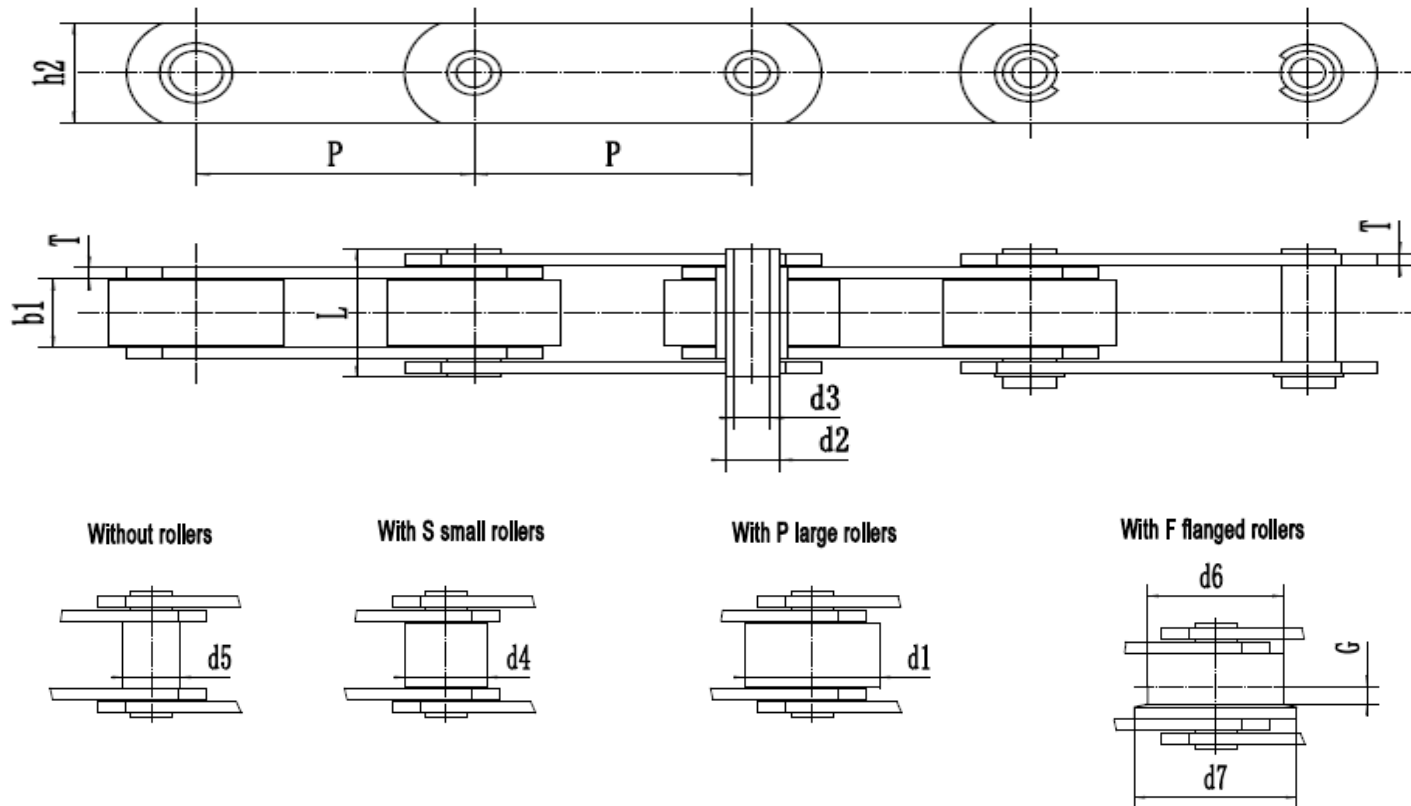

ZMIE Chain No.	Pitch					
	P					
	mm					
FVC63	63.0	80.0	100.0	125.0	160.00	-

FVC90	63.0	80.0	100.0	125.0	160.00	200.0
FVC112	100.0	125.0	160.0	200.0	250.00	-
FVC140	100.0	125.0	160.0	200.0	250.00	-
FVC180	125.0	160.0	200.0	250.0	315.00	-
FVC250	160.0	200.0	250.0	315.0	400.00	-
FVC315	160.0	200.0	250.0	315.0	400.00	-

Roller diameter					Bush diameter
d1 max		d6 max	d7 max	G	d5 max
mm	mm	mm	mm	mm	mm
40.0	26	50.0	63.0	5.0	18.0
48.0	30	63.0	78.0	6.5	20.0
55.0	32	72.0	90.0	7.5	22.0
60.0	36	80.0	100.0	9.0	26.0
70.0	42	100.0	125.0	13.0	30.0
80.0	50	125.0	155.0	15.0	36.0
90.0	60	140.0	175.0	18.0	42.0

ZMIE Chain No.	Width between inner plates	Pin diameter		Pin length	Plate depth	Plate thickness	Ultimate tensile strength
	b1 min	d2 max	d3 min	L max	h2 max	T max	Q min
	mm	mm	mm	mm	mm	mm	KN/LB
FVC63	22.0	12.0	8.0	45.0	30.00	4.0	46/10350
FVC90	25.0	14.0	10.0	53.0	35.00	5.0	73/16425
FVC112	30.0	16.0	11.0	62.0	40.00	6.0	90/20250
FVC140	35.0	18.0	12.0	67.0	45.00	6.0	110/24750
FVC180	45.0	20.0	14.0	86.0	50.00	8.0	145/32625
FVC250	55.0	26.0	18.0	97.0	60.00	8.0	215/48375
FVC315	65.0	30.0	20.0	117.0	70.00	10.0	295/66375