

Australian/New Zealand Standard™

**Cold-formed structural steel hollow  
sections**



## **AS/NZS 1163:2016**

This Joint Australian/New Zealand Standard was prepared by Joint Technical Committee BD-023, Structural Steel. It was approved on behalf of the Council of Standards Australia on 13 January 2016 and on behalf of the Council of Standards New Zealand on 21 January 2016.

This Standard was published on 5 April 2016.

---

The following are represented on Committee BD-023:

Australian Chamber of Commerce and Industry  
Australian Industry Group  
Australian Steel Association  
Australian Steel Institute  
Austroads  
Bureau of Steel Manufacturers of Australia  
Business New Zealand  
New Zealand Heavy Engineering Research Association  
Steel Construction New Zealand  
University of New South Wales  
University of Sydney

---

### **Keeping Standards up-to-date**

Standards are living documents which reflect progress in science, technology and systems. To maintain their currency, all Standards are periodically reviewed, and new editions are published. Between editions, amendments may be issued. Standards may also be withdrawn. It is important that readers assure themselves they are using a current Standard, which should include any amendments which may have been published since the Standard was purchased.

Detailed information about joint Australian/New Zealand Standards can be found by visiting the Standards Web Shop at [www.saiglobal.com.au](http://www.saiglobal.com.au) or Standards New Zealand web site at [www.standards.co.nz](http://www.standards.co.nz) and looking up the relevant Standard in the on-line catalogue.

For more frequent listings or notification of revisions, amendments and withdrawals, Standards Australia and Standards New Zealand offer a number of update options. For information about these services, users should contact their respective national Standards organization.

We also welcome suggestions for improvement in our Standards, and especially encourage readers to notify us immediately of any apparent inaccuracies or ambiguities. Please address your comments to the Chief Executive of either Standards Australia or Standards New Zealand at the address shown on the back cover.

---

*This Standard was issued in draft form for comment as DR AS/NZS 1163.*

---

# Australian/New Zealand Standard™

## **Cold-formed structural steel hollow sections**

Originated in Australia as AS A177—1969.  
Previous and first joint edition AS/NZS 1163:2009.  
Fifth edition 2016.

### **COPYRIGHT**

© Standards Australia Limited/Standards New Zealand

All rights are reserved. No part of this work may be reproduced or copied in any form or by any means, electronic or mechanical, including photocopying, without the written permission of the publisher, unless otherwise permitted under the Copyright Act 1968 (Australia) or the Copyright Act 1994 (New Zealand).

Jointly published by SAI Global Limited under licence from Standards Australia Limited, GPO Box 476, Sydney, NSW 2001 and by Standards New Zealand, PO Box 10729, Wellington 6011.

## PREFACE

This Standard was prepared by the Standards Australia/Standards New Zealand Committee BD-023, Structural Steel, to supersede AS/NZS 1163:2009.

The objective of this Standard is to specify the requirements for manufacturers and suppliers of longitudinal welded cold-formed structural steel hollow sections for general structural and engineering applications.

This edition incorporates the following major changes to the previous edition:

- (a) Requirements for type testing and minimum production testing and inspections have been included in the normative Appendix on product conformity.
- (b) Test certificates are required to be available for all products produced to this Standard.
- (c) Alignment of definitions associated with test unit, test product, test sample, test specimen and test piece as noted in ISO 404, AS/NZS 3678, AS/NZS 3679.1 and AS/NZS 3679.2.
- (d) Inclusion of notations and additional definitions in Section 3.
- (e) The inclusion of cold-rolled and annealed coil with hot-rolled coil for steel feed.
- (f) Revision to the chemical composition part of the Standard, which includes a new set of limits for finished product analysis.
- (g) Provisions for suitability for zinc coating have been moved to the Appendix on purchasing guidelines.
- (h) Reformatting of the freedom from defects and testing provisions of the Standard.
- (i) Inclusion of the provision for individual length markings for New Zealand.
- (j) Minor revision to test and inspection certificates.
- (k) A new Appendix on formulae for calculating cross-section properties.
- (l) Definitions, clause numbering and layout across the four steel-product Standards AS/NZS 1163, AS/NZS 3678, AS/NZS 3679.1 and AS/NZS 3679.2 are consistent wherever possible.

A statement expressed in mandatory terms in a note to a table is deemed to be a requirement of this Standard.

The terms 'normative' and 'informative' have been used in this Standard to define the application of the appendix to which they apply. A 'normative' appendix is an integral part of a Standard, whereas an 'informative' appendix is only for information and guidance.

## CONTENTS

	<i>Page</i>
1 SCOPE .....	4
2 NORMATIVE REFERENCES .....	4
3 DEFINITIONS AND NOTATIONS .....	5
4 DESIGNATION .....	9
5 MANUFACTURING PROCESS .....	9
6 CHEMICAL COMPOSITION .....	10
7 MANUFACTURING TOLERANCES .....	11
8 FREEDOM FROM DEFECTS .....	17
9 TESTING .....	18
10 MECHANICAL PROPERTIES .....	21
11 IDENTIFICATION, TEST AND INSPECTION CERTIFICATES .....	22
12 SAMPLING AND TESTING TO DEMONSTRATE PRODUCT CONFORMITY ..	24
13 ROUNDING OF NUMBERS .....	24
14 MANIPULATION .....	24
15 SECTION DESIGNATIONS, NOMINAL DIMENSIONS, CROSS-SECTION PROPERTIES AND MASSES .....	24
APPENDICES	
A PURCHASING GUIDELINES .....	25
B PRODUCT CONFORMITY .....	27
C MANIPULATION .....	34
D SECTION DESIGNATIONS, DIMENSIONS AND CROSS-SECTION PROPERTIES .....	35
E FORMULAE FOR THE CALCULATION OF SECTIONAL PROPERTIES .....	45
BIBLIOGRAPHY .....	48

## STANDARDS AUSTRALIA/STANDARDS NEW ZEALAND

---

**Australian/New Zealand Standard**  
**Cold-formed structural steel hollow sections**

---

**1 SCOPE**

This Standard specifies the requirements for the production and supply of cold-formed, electric resistance-welded, steel hollow sections used for structural purposes. It considers three strength grades, with or without impact properties, that are suitable for welding.

This Standard applies to structural hollow sections formed cold without subsequent heat treatment.

This Standard is intended for general structural and engineering applications. All grades specified in this Standard are suitable for—

- (a) welding, in accordance with AS/NZS 1554, Parts 1, 2, 5 and 7; and
- (b) fastening, as specified in AS 3990, AS 4100, AS/NZS 4600, AS 5100.6 and NZS 3404.

The Standard does not cover—

- (i) submerged arc-welded;
- (ii) helically welded; or
- (iii) U'ed and O'ed steel hollow sections.

Requirements for product conformity to this Standard are given in Appendix B.

Requirements for cold-bending of galvanized circular hollow sections are given in Appendix C.

NOTE: Guidelines to purchasers on requirements that should be specified by the purchaser and those that should or may be agreed on at the time of enquiry and order are given in Appendix A.

**2 NORMATIVE REFERENCES**

The following normative documents are referenced in this Standard:

NOTE: Documents referenced for informative purposes are listed in the Bibliography.

**AS**

1391	Metallic materials—Tensile testing at ambient temperature
1544	Methods for impact tests on metals
1544.2	Part 2: Charpy V-notch
1733	Methods for the determination of grain size in metals
2706	Numerical values—Rounding and interpretation of limiting values
3990	Mechanical equipment—Steelwork
4100	Steel structures
5100	Bridge design
5100.6	Part 6: Steel and composite construction

**AS/NZS**

1050	Methods for the analysis of iron and steel (series)
1050.1	Part 1: Sampling iron and steel for chemical analysis

AS/NZS	
1554	Structural steel welding
1554.1	Part 1: Welding of steel structures
1554.2	Part 2: Stud welding (steel studs to steel)
1554.5	Part 5: Welding of steel structures subject to high levels of fatigue loading
1554.7	Part 7: Welding of sheet steel structures
4600	Cold-formed steel structures
ISO	
643	Steels—Micrographic determination of the apparent grain size
2566	Steel—Conversion of elongation values
2566-1	Part 1: Carbon and low alloy steels
7870	Control charts
7870-3	Part 3: Acceptance control charts
10893	Non-destructive testing of steel tubes
10893-2	Part 2: Automated eddy current testing of seamless and welded (except submerged arc-welded) steel tubes for the detection of imperfections
10893-3	Part 3: Automated full peripheral flux leakage testing of seamless and welded (except submerged arc-welded) ferromagnetic steel tubes for the detection of longitudinal and/or transverse imperfections
10893-11	Part 11: Automated ultrasonic testing of the weld seam of welded steel tubes for the detection of longitudinal and/or transverse imperfections
14284	Steel and iron—Sampling and preparation of samples for the determination of chemical composition
NZS	
3404	Steel Structures Standard
3404.1	Part 1: Materials, fabrication and construction

### 3 DEFINITIONS AND NOTATIONS

The notations used in this Standard are listed in Table 1.

For the purpose of this Standard, the definitions below apply.

#### 3.1 Analysis

##### 3.1.1 *Cast analysis*

Chemical analysis determined from test samples taken from the ladle, tundish or mould during casting.

##### 3.1.2 *Product analysis*

Chemical analysis determined from a test sample of the finished product.

#### 3.2 Batch

Hollow sections of the same size, nominal thickness and grade manufactured from the same heat, tube forming process (tube mill) and rolling (roll set up).

#### 3.3 Can

To denote a capability or possibility that is available or that might occur.

#### 3.4 Cold-formed hollow section

Hollow section formed and shaped at ambient temperature from a single strip of steel, both edges of which are continuously welded by the contact tip or induction coil electric resistance process.

### **3.5 Cold-rolled and annealed coil**

Flat product manufactured by cold-rolling and subsequent annealing of hot-rolled coil.

Cold-rolled coil is hot-rolled coil that has been subjected to a cold-rolling reduction of more than 15%. The coil shall have a subcritical annealing cycle that recrystallises the structure and forms new ferrite grains. The resulting properties are similar to hot-rolled coil.

### **3.6 Crack**

Narrow line of fracture on the surface.

### **3.7 Defects**

Surface discontinuities, including cracks, laps and seams, in the base material and out-of-tolerance weld seams.

### **3.8 Factory production control**

Operational techniques and all measures necessary to regulate and maintain the conformity of the product to the requirements of the relevant product Standard.

### **3.9 Fine grained steels**

Steels which have an austenitic grain size of number 6 or finer when tested in accordance with AS 1733. Generally, steels are considered fine grained without the need for testing when the total aluminium content is greater than 0.020%, or when niobium  $\geq 0.01\%$ , titanium  $\geq 0.01\%$  or vanadium  $\geq 0.02\%$  are deliberately added as carbonitride formers.

NOTE: AS 1733 includes various recognized methods for grain size determination, including the McQuaid-Ehn method, and appropriate etching techniques.

### **3.10 Heat**

A product of a ladle of steel melted in one vessel and processed under the same conditions.

### **3.11 Hot-rolled coil**

Flat product manufactured by hot-rolling semi-finished products.

Includes products that have been subjected to a light cold-rolling pass, normally less than 5% reduction, known as a 'skin pass'.

### **3.12 Inspection**

Judgement by competent personnel to determine acceptability against requirements.

### **3.13 Lap**

Overlapping material partially connected with the base material.

### **3.14 Longitudinal direction**

Direction parallel to the longitudinal weld seam.

### **3.15 Longitudinal weld seam**

Continuous weld joining both edges of the single strip of steel used to form a hollow section.

### **3.16 Manufacturer**

The business operating either the steel feed (Clause 5.1) or the finished product (Clause 5.2) manufacturing process.

### **3.17 May**

Indicates the existence of an option.



**3.18 Purchaser**

Organization or person who is a recipient from a supplier of a steel product manufactured to this Standard.

**3.19 Seams (defect)**

Caused when defects in the semi-finished product are elongated and extended during rolling.

**3.20 Shall**

Indicates that a statement is mandatory.

**3.21 Should**

Indicates a recommendation.

**3.22 Structural hollow sections**

Tube intended to be used for structural purposes.

**3.23 Supplier**

An organization or person that provides a steel products manufactured to this Standard.

**3.24 Testing**

Chemical analysis tests and mechanical tests undertaken by an accredited laboratory as required by this Standard.

**3.25 Test piece**

Piece prepared for testing, made from a test specimen by a mechanical operation.

**3.26 Test sample**

Portion of material or product, or a group of items selected from a test batch or group by a sampling procedure.

**3.27 Test specimen**

Portion or a single item taken from the test sample for the purpose of eventually applying a particular test.

**3.28 Transverse direction**

Direction at right angles to the longitudinal weld seam.

**3.29 Type testing**

Testing performed to prove that the material is capable of conforming to the requirements of this Standard.

**3.30 Unit**

Length of hollow section.

**TABLE 1**  
**NOTATION**

Symbol	Unit	Description
$A$	mm <sup>2</sup>	cross-sectional area
$A_{EL}$	m <sup>2</sup> /m	external surface area per unit length
$A_{EM}$	m <sup>2</sup> /t	external surface area per unit mass
$A_{cri}$	mm <sup>2</sup>	intermediate term for the calculation of internal corner radius properties
$A_{cro}$	mm <sup>2</sup>	intermediate term for the calculation of external corner radius properties
$A_g$	mm <sup>2</sup>	gross area of the cross-section
$A_h$	mm <sup>2</sup>	intermediate term for the calculation of $J$ and $C$
$b$	mm	nominal side dimension of a square hollow section (SHS) or shorter side of a rectangular hollow section (RHS)
$C$	mm <sup>3</sup>	torsion modulus
$c_1, c_2$	mm	length of external corner profile of a square or rectangular hollow section
$d$	mm	nominal dimension of the longer side of a rectangular hollow section (RHS)
$d_i$	mm	inside diameter of a circular hollow section (CHS) (for calculation purposes)
$d_o$	mm	nominal outside diameter of a circular hollow section
$d_{o_{max.}}, d_{o_{min.}}$	mm	maximum and minimum outside external diameter of a circular hollow section, measured in the same plane
$e$	mm	deviation from straightness
$h_{cri}$	mm	intermediate term for the calculation of internal corner radius properties
$h_{cro}$	mm	intermediate term for the calculation of external corner radius properties
$I$	mm <sup>4</sup>	second moment of area
$I_{cri}$	mm <sup>4</sup>	intermediate term for the calculation of internal corner radius properties
$I_{cro}$	mm <sup>4</sup>	intermediate term for the calculation of external corner radius properties
$J$	mm <sup>4</sup>	torsion constant (polar moment of inertia for circular hollow sections only)
$K$	mm <sup>2</sup>	intermediate term for the calculation of $J$ and $C$
$L$	mm	length
$L_o$	mm	gauge length
$m$	kg/m	mass per unit length
$n$	—	diagonal axis passing through the opposing corner radii of a square hollow section (SHS)
$o$	%	out-of-roundness
$R_c$	mm	average of outer and inner corner radius for calculation purposes
$r$	mm	radius of gyration
$r_i$	mm	internal corner radius of a square or rectangular hollow section (for calculation purposes)
$r_o$	mm	external corner radius of a square or rectangular hollow section
$S$	mm <sup>3</sup>	plastic section modulus
$S_o$	mm <sup>2</sup>	original cross-sectional area
$t$	mm	nominal thickness
$v$	mm	total twist

(continued)

TABLE 1 (continued)

Symbol	Unit	Description
$v_1$	mm	twist measured at one end of a section
$x$	—	major principal axis
$x_1$	mm	concavity of a side of a square or rectangular hollow section
$x_2$	mm	convexity of a side of a square or rectangular hollow section
$y$	—	minor principal axis
$Z$	mm <sup>3</sup>	elastic section modulus
$\theta$	degrees	angle between adjacent sides of a square or rectangular hollow section
$\pi$	3.14159	pi

#### 4 DESIGNATION

All grades shall be designated in the format shown in the following:

*Examples:*

AS/NZS 1163–C350

AS/NZS 1163–C350L0

where

AS/NZS 1163 = number of this Standard

C = cold-formed sections

350 = minimum yield strength in MPa (see Table 7)

L = guaranteed impact properties of the material (when applicable)

0 = low temperature impact test at 0°C (when applicable)

#### 5 MANUFACTURING PROCESS

##### 5.1 Steel feed

The steel shall be made by the basic oxygen process or an electric arc process.

Additional refining by vacuum arc remelt, electroslag refining or secondary steelmaking practices such as vacuum degassing or calcium injection, or both, is permitted.

The steel shall be fine grained and be made from fully killed, continuously cast steels. The coil shall be hot-rolled coil from a hot strip mill. Further processing of the coil by cold-rolling and annealing is permitted.

Cold-rolled coil is hot-rolled coil that has been subjected to a cold-rolling reduction of more than 15%. The coil shall have a subcritical annealing cycle that recrystallizes the structure and forms new ferrite grains. The resulting properties are similar to hot-rolled coil.

##### 5.2 Finished product

The finished hollow section product shall be manufactured by the cold-forming process and use electric resistance-welding techniques to join the strip edges. The weld seam is to be longitudinal and shall have the external upset removed. There shall be no subsequent overall heat treatment on the finished product.

## 6 CHEMICAL COMPOSITION

### 6.1 General

The method of sampling for chemical analysis shall be in accordance with AS/NZS 1050.1 or ISO 14284. Chemical composition shall be determined in accordance with AS/NZS 1050 series Standards or other procedures that achieve the same, or better, degree of accuracy.

### 6.2 Cast analysis

A cast analysis of the steel shall be made from each heat to determine the proportions of the specified elements. In cases where it is impracticable to obtain samples from the liquid steel, analysis on test samples taken in accordance with AS/NZS 1050.1 or ISO 14284 may be reported as cast analysis.

The cast analysis of the steel shall conform to the limits given in Table 2 for the appropriate grade.

### 6.3 Product analysis

Chemical analysis of the finished product is not a requirement of this Standard. If the steel is subjected to a finished product analysis, the chemical composition shall conform to the limits given in Table 2 with the tolerances given in Table 3.

**TABLE 2**  
**CHEMICAL COMPOSITION**

Grades (see Note 1)	Chemical composition (cast or product analysis) (see Note 2) % max.										
	C	Si	Mn	P	S	Cr	Mo	Al (see Note 3)	Ti	Micro-alloying elements	CE (see Note 4)
C250, C250L0	0.12	0.05	0.50	0.03	0.03	0.15	0.10	0.10	0.04	0.03 (see Note 5)	0.25
C350, C350L0	0.20	0.25	1.60	0.03	0.03	0.30	0.10	0.10	0.04	0.15 (see Note 6)	0.43
C450, C450L0	0.20	0.25 (see Note 7)	1.70	0.03	0.03	0.30	0.35	0.10	0.04	0.15 (see Note 6)	0.43

NOTES:

1 The use of sulphide modification manufacturing techniques for these grades is permitted.

2 The following elements may be present to the limits stated:

- (a) Copper 0.25%.
- (b) Nickel 0.25%.

3 Limits specified are for soluble or total aluminium.

4 Carbon equivalent (CE) is calculated from the following equation:

$$CE = C + \frac{Mn}{6} + \frac{Cr + Mo + V}{5} + \frac{Ni + Cu}{15}$$

5 Applies to niobium and vanadium only. However, niobium greater than 0.010% is not permitted.

6 Applies to niobium, vanadium and titanium only. However, vanadium greater than 0.10% is not permitted.

7 For circular hollow sections (CHS), the silicon limit shall be 0.45.

**TABLE 3**  
**PRODUCT ANALYSIS TOLERANCES**  
**FOR GRADES GIVEN IN TABLE 2**

Element	Tolerance over maximum limit %
Carbon	0.02
Silicon	0.05
Manganese	0.10
Phosphorous	0.005
Sulphur	0.005
Chromium	0.05
Nickel	0.05
Molybdenum	0.03
Copper	0.04
Aluminium (total)	-0.005
Micro-alloying elements (niobium and vanadium only) for Grades C250, C250L0	0.06 with niobium no greater than 0.020
Micro-alloying elements (niobium, vanadium and titanium only) for Grades C350, C350L0, C450, C450L0	0.19 with vanadium no greater than 0.12

## 7 MANUFACTURING TOLERANCES

### 7.1 General

Tolerances and limits on the dimensions and mass of cold-formed hollow sections shall conform with the values given in—

- (a) Table 4, for shape and mass;
- (b) Table 5, for external corner profiles; and
- (c) Table 6, for length.

Where relevant, Tables 4, 5 and 6 shall be read in conjunction with Clause 7.2.

The internal corners of square and rectangular hollow sections shall be rounded.

NOTE: The internal corner profile is not specified.

**TABLE 4**  
**TOLERANCES FOR SHAPE AND MASS**

<b>Characteristic</b>	<b>Circular hollow sections</b>	<b>Square and rectangular hollow sections</b>
External dimensions ( $d_o$ , $d$ and $b$ )	$\pm 1\%$ , with a minimum of $\pm 0.5$ mm and a maximum of $\pm 10$ mm	$\pm 1\%$ , with minimum of $\pm 0.5$ mm
Thickness ( $t$ )	For $d_o \leq 406.4$ mm: $\pm 10\%$ For $d_o > 406.4$ mm: $\pm 10\%$ with a max of $\pm 2$ mm	$\pm 10\%$
Out-of-roundness ( $o$ )	$\pm 2\%$ for hollow sections having a diameter to thickness ratio not exceeding 100 (see Note 1)	—
Concavity/convexity (see Note 2)	—	Max. 0.8% or 0.5 mm, whichever is greater
Squareness of sides	—	$90^\circ \pm 1^\circ$
External corner profile	—	See Table 5
Twist ( $v$ )	—	2 mm + 0.5 mm/m length
Straightness (see Note 3)	0.20% of total length	0.15% of total length
Mass ( $m$ ) per unit length	Not less than 0.96 times the specified mass (Note 4) on individual lengths	

## NOTES:

- 1 Where the diameter to thickness ratio exceeds 100, the tolerance on out-of-roundness becomes the subject of agreement between the manufacturer and purchaser.
- 2 The tolerance on convexity and concavity is independent of the tolerance on external dimensions.
- 3 The straightness tolerance applies to straightness in any one plane.
- 4 In lieu of any other requirement, the specified mass is considered to be the nominal mass as noted in Clause 15.

**TABLE 5**  
**EXTERNAL CORNER PROFILE**

<b>Perimeter</b>	<b>External corner profile</b>
<b>mm</b>	<b>(<math>c_1</math>, <math>c_2</math> or <math>r_o</math>) (see Note)</b>
Equivalent to $50 \times 50$ or less	$1.5t$ to $3.0t$
Equivalent to greater than $50 \times 50$	$1.8t$ to $3.0t$

NOTE: The sides need not be tangential to the corner arcs.

**TABLE 6**  
**TOLERANCES ON LENGTH (see Note)**

Type of length	Range mm	Tolerance
Random length	4000 to 16 000 with a range of 2000 per order item	10% of sections supplied may be below the minimum for the ordered range but not less than 75% of the minimum
Mill (or 'unspecified') length	All	+100 mm -0
Precision length	<6000	+5 mm -0
	≥6000 ≤10 000	+15 mm -0
	>10 000	+5 mm + 1 mm/m -0

NOTE: The enquiry and order shall indicate the type of length required and the length or length range, as appropriate. Alternatively, length tolerances shall be specified at the time of order.

**7.2 Measurement of size and shape**

**7.2.1 General**

All external dimensions shall be measured at a distance from the end of the hollow section of not less than  $d_o$  for circular sections,  $b$  for square sections and  $d$  for rectangular sections, with a minimum of 100 mm.

**7.2.2 External dimensions**

For circular hollow sections, the diameter ( $d_o$ ) shall be measured.

The limiting cross-sectional positions for measuring  $b$  and  $d$  of square and rectangular hollow sections are shown in Figure 1.

NOTE: A caliper gauge, circumference tape or other suitable device may be used at the discretion of the manufacturer.

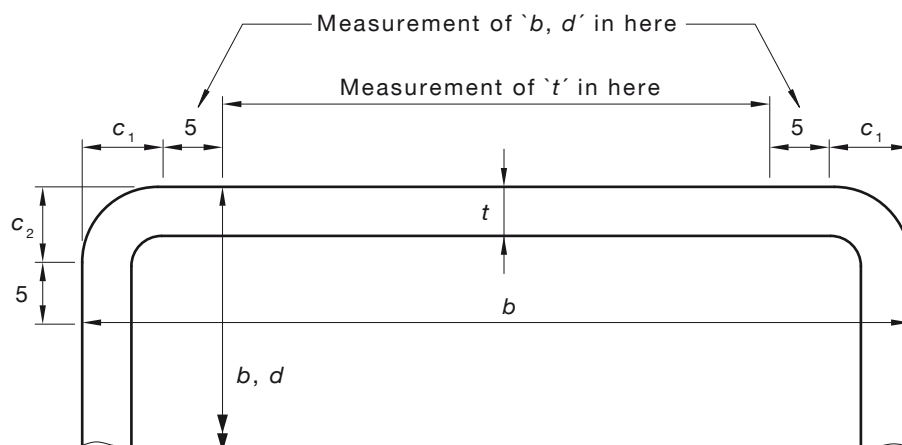

NOTE: The 5 mm dimension is a maximum when measuring  $b$  or  $d$ , and a minimum when measuring  $t$ .

DIMENSIONS IN MILLIMETRES

**FIGURE 1 LIMITING CROSS-SECTIONAL POSITIONS FOR MEASURING DIMENSIONS  $b$ ,  $d$  AND  $t$  FOR SQUARE OR RECTANGULAR HOLLOW SECTIONS**

**7.2.3 Thickness**

The thickness ( $t$ ) shall be measured at a position of not less than  $2t$  or 25 mm, whichever is lesser, from the weld seam.

The limiting cross-sectional positions for measuring the thickness of square and rectangular hollow sections are shown in Figure 1.

NOTE: Thickness is normally measured within a distance of half the outside diameter or half the longer side length from the end of the section.

**7.2.4 Out-of-roundness**

The out-of-roundness ( $o$ ) of a circular hollow section shall be calculated as a percentage, from the following equation:

$$o = \frac{d_{o\max.} - d_{o\min.}}{d_o} \times 100 \quad \dots 7.2.4$$

**7.2.5 Concavity and convexity**

The concavity ( $x_1$ ) or the convexity ( $x_2$ ) of the sides of a square or rectangular hollow section shall be measured as shown in Figure 2.

The percentage concavity or convexity shall be calculated as follows:

$$\frac{x_1}{b} \times 100\%$$

$$\frac{x_2}{b} \times 100\%$$

$$\frac{x_1}{d} \times 100\%$$

$$\frac{x_2}{d} \times 100\%$$

where

$b$  and  $d$  are the lengths of the sides containing the concavity ( $x_1$ ) or the convexity ( $x_2$ ).

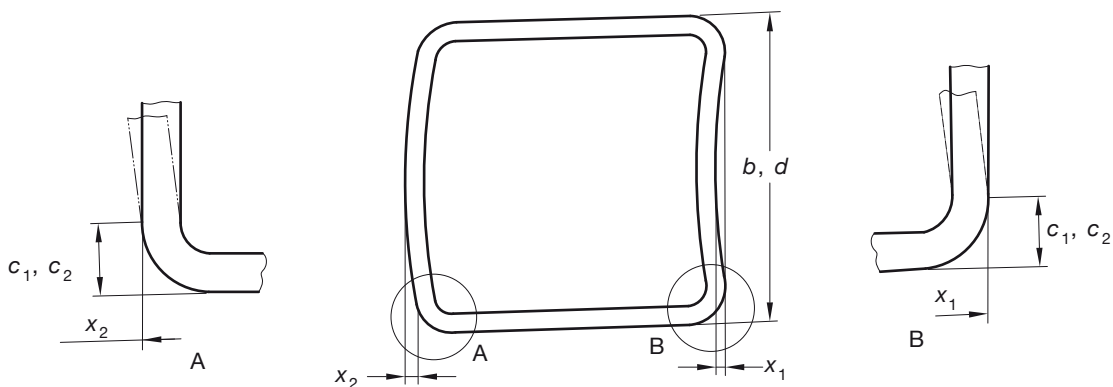
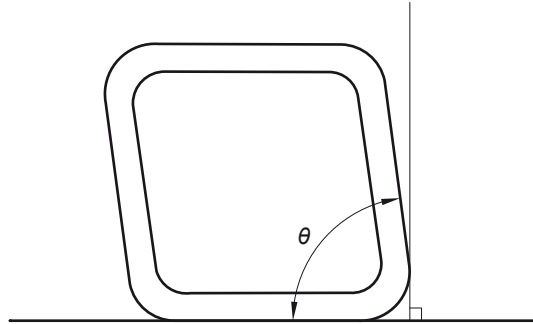

FIGURE 2 MEASUREMENT OF CONCAVITY/CONVEXITY OF SQUARE OR RECTANGULAR HOLLOW SECTIONS



7.2.6 Squareness of sides

The deviation from squareness of the sides of a square or rectangular hollow section is defined as the difference between 90° and  $\theta$  as shown in Figure 3.



Deviation from squareness =  $90^\circ - \theta$

FIGURE 3 SQUARENESS OF SIDES OF SQUARE OR RECTANGULAR HOLLOW SECTIONS

7.2.7 External corner profile

The external corner profile of a square or rectangular hollow section shall be measured at the discretion of the manufacturer, as follows:

- (a) Measure the external corner radius ( $r_o$ ). Use a radius gauge or other suitable device.
- (b) Measure the length of the external corner profile ( $c_1$  and  $c_2$ ) (see Figure 4).

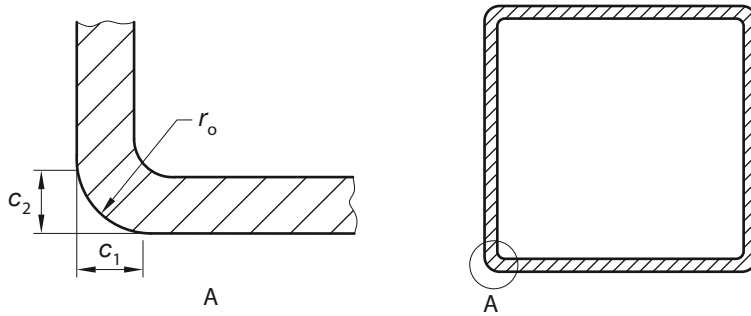

NOTE:  $c_1$  and  $c_2$  can be measured as the distance between the intersection of the flat side and the corner arc and the intersection of the line projections of the flat sides to the corner.

FIGURE 4 EXTERNAL CORNER PROFILE OF SQUARE OR RECTANGULAR HOLLOW SECTIONS

### 7.2.8 Twist

The total twist ( $v$ ) in a square or rectangular hollow section shall be determined, at the discretion of the manufacturer, as follows:

- Place the hollow section on a horizontal surface with one side at one end pressed flat against the surface. At the opposite end of the hollow section, determine the difference of  $v$  in the height of the two lower corners from a horizontal surface (see Figure 5).
- Measure  $v$  with a spirit level and micrometer (screw) gauge or other suitable device. The reference length of the spirit level shall be the distance between the intersection of the flat sides and the external corner profile (see Figure 6).  $v$  is the difference between the values  $v_1$  (see Figure 6) measured at each end of the section.

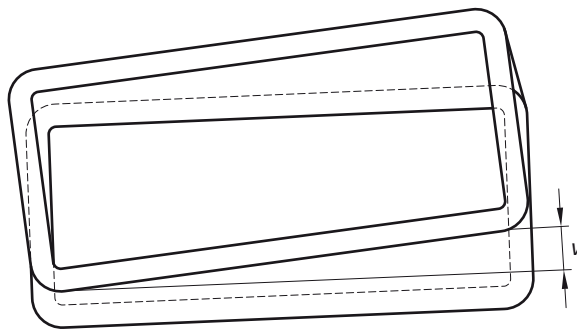
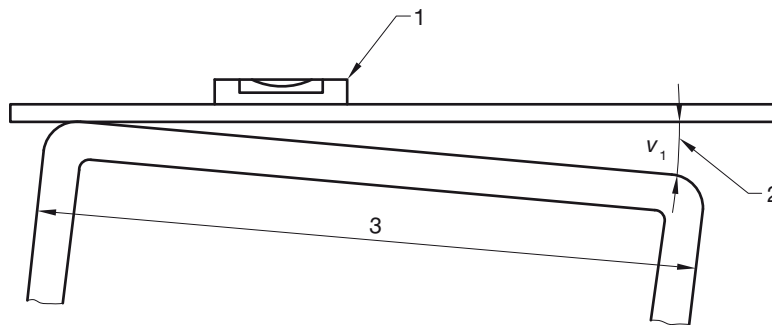

FIGURE 5 TOTAL TWIST OF SQUARE OR RECTANGULAR HOLLOW SECTIONS



Legend:

- Spirit level
- Micrometer gauge
- $d$  for rectangular sections,  $b$  for square sections

FIGURE 6 MEASUREMENT OF TWIST

### 7.2.9 Straightness

The deviation from straightness ( $e$ ) of the total length of a hollow section shall be measured at the point of maximum departure of the section from a straight line connecting its two ends, as shown in Figure 7. The percentage deviation from straightness shall be calculated as follows:

$$\frac{e}{L} \times 100\%$$

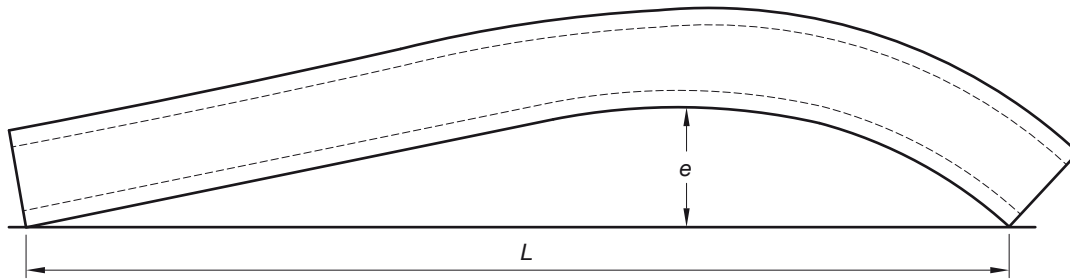

FIGURE 7 MEASUREMENT OF DEVIATION FROM STRAIGHTNESS

#### 7.2.10 Removal of the external weld seam upset

After removal of the external weld upset, the remaining weld seam (excluding the upset beyond the inner surface) and wall thickness in the adjacent area shall not be less than 90% of the nominal wall thickness.

## 8 FREEDOM FROM DEFECTS

### 8.1 General

The finished product shall be free from defects that are detrimental to the material's structural integrity.

### 8.2 Weld seam

#### 8.2.1 Position

For rectangular and square hollow sections, the weld seam shall not be placed within a distance of three times the wall thickness from the apex of the corner radius.

#### NOTES:

- 1 The apex of the corner radius is defined as the intersection point of the lines emanating from two external adjoining faces of the hollow section.
- 2 Some end-use applications may require the weld seam to be placed close to the corner radius. This should be noted at the time of enquiry or order (see Appendix A) with the finished hollow sections not exhibiting any cracking or brittle behaviour. For the adequate performance of the corner radius and weld seam, such hollow sections are not considered to be in the scope of this Standard.

#### 8.2.2 Non-destructive examination

At the manufacturer's discretion, the weld seam of welded structural hollow sections may be subjected to non-destructive examination (NDE). The NDE may be carried out either on the circular shape prior to final forming or on the hollow sections after final forming.

Where NDE is employed, the weld seam shall be tested in accordance with one of the following:

- (a) ISO 10893-2 to acceptance Level L4, except that the rotating tube/pancake coil technique shall not be permitted.
- (b) ISO 10893-3 or ISO 10893-11, with the exception that the acceptance level shall be based on, at minimum, the use of N15 internal/external notches and for the application of ISO 10893-3, a notch of no greater than twice the depth of the reference notch, with a maximum of 1.0 mm, shall apply.

### 8.3 Removal of surface defects

When removal of surface defects by grinding is adopted, the ground area shall be well-transitioned and the remaining wall thickness in the ground areas shall be not less than 90% of the nominal thickness.

## 8.4 Weld repair of surface defects

Welding used in the repair of surface defects shall utilize a low-hydrogen process in accordance with AS/NZS 1554.1.

Welds shall be sound, the weld being thoroughly fused without undercutting or overlap. The weld metal shall project at least 1.5 mm above the rolled surface and the projecting metal shall be removed by grinding flush with the rolled surface.

## 9 TESTING

### 9.1 Selection of test samples

Test samples for the preparation of test pieces for tensile, impact and cold-flattening tests shall be taken in accordance with Clause 9.2. Subject to the requirements of Clause 9.3.4, test pieces shall be in the same condition as the finished product. Test samples shall be representative of the body of the product.

### 9.2 Position and orientation of test pieces

#### 9.2.1 Tensile test and impact test

The test piece shall be cut such that the major axis is in the longitudinal direction and shall be selected from any position along the length of the test specimen such that the requirements of Clause 9.3.2 or 9.3.3 are complied with.

#### 9.2.2 Cold flattening test

The test piece shall be cut in the transverse direction and shall be cut from one end of a test specimen that contains a longitudinal weld seam.

### 9.3 Preparation of test pieces for mechanical testing

#### 9.3.1 General

Test specimens may be straightened cold before preparation in accordance with this Standard. A test piece which shows defective machining or develops flaws may be discarded and another test specimen may be submitted.

#### 9.3.2 Tensile test piece

##### 9.3.2.1 Form of test piece

The test piece shall be in the form given in either Item (a) or (b) as follows:

- (a) A test piece with dimensions conforming to those specified in Table C2 of AS 1391—2007, cut from the test specimen. The cross-section location of the test specimen shall be as specified in Clauses 9.3.2.2 or 9.3.2.3, as appropriate.
- (b) A length of the full section test specimen.

The test piece shall be aged in accordance with Clause 9.3.4.

##### 9.3.2.2 Circular hollow sections (CHS)

For a length of circular hollow section, the test specimen shall be taken at approximately 90° from the weld seam [see Figure 8(a)].

The tensile test piece cut from a test specimen shall not be flattened between gauge marks.

##### 9.3.2.3 Rectangular hollow section (RHS)

The tensile test piece cut from a test specimen shall be taken from any side midway between and excluding the corners [see Figure 8(b)]. The test piece shall not include a longitudinal weld seam.

**9.3.3 Impact test piece**

Three test pieces shall be prepared from each test specimen and cut parallel to the longitudinal axis of the hollow section, with the axis of the notch perpendicular to the rolled surface of the section (see Figure 8).

For circular and rectangular hollow sections, the cross-section location of the test specimen shall be as specified in Figure 8 where, for rectangular hollow sections, it shall also be remote from the weld seam. The test piece shall be prepared in accordance with AS 1544.2 using, where necessary, the largest practicable subsidiary test piece with a width not less than 5 mm. For a standard sized test specimen (i.e. 10 mm × 10 mm), the finally machined test pieces shall be extracted from the mid-thickness of the hollow section wall.

The test piece shall be aged in accordance with Clause 9.3.4.

**9.3.4 Ageing treatment**

Prior to tensile or impact testing, the test pieces shall be aged by heating to a temperature between 150°C and 200°C for not less than 15 min.

**9.3.5 Cold flattening test**

The test piece shall be taken in the form of a cross-section from one end of a finished length of a circular hollow section which contains a longitudinal weld seam. The length of the test piece shall be not less than 40 mm.

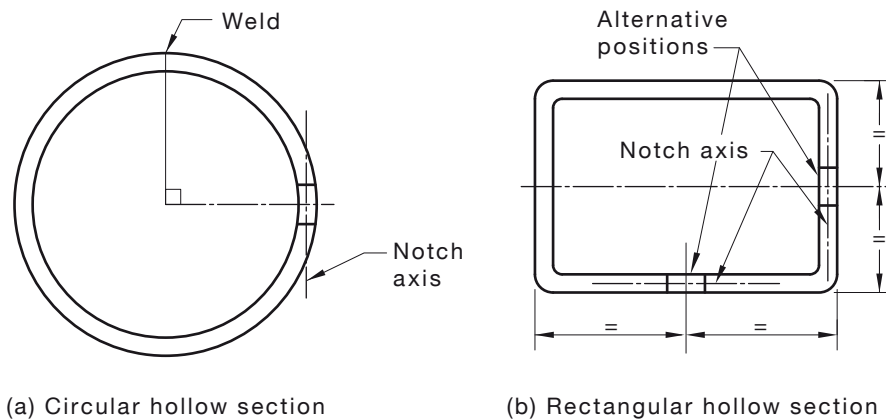

(a) Circular hollow section

(b) Rectangular hollow section

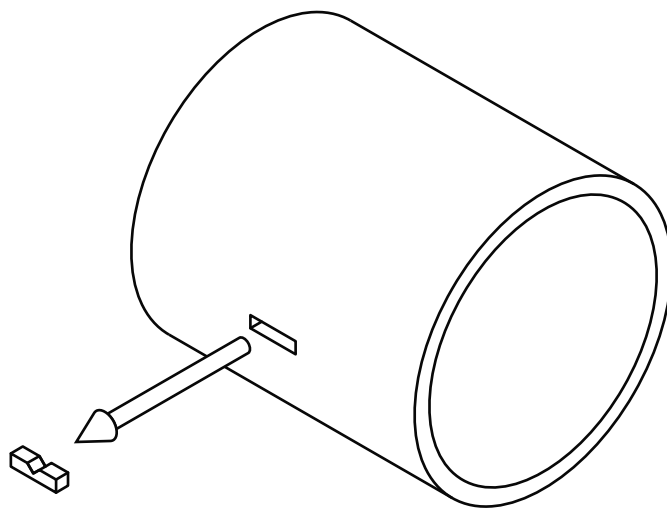

(c) Notch orientation for impact test specimen (applies to CHS and RHS)

**FIGURE 8 CROSS-SECTION POSITION OF TEST SPECIMEN FOR TENSILE AND IMPACT TESTS**

## 9.4 Mechanical testing

### 9.4.1 Tensile test

A tensile test shall be made on each test piece prepared from each test sample specified in Clause 9.1

The tensile test shall be carried out in accordance with AS 1391. The rate of straining when approaching the yield strength shall be within the limits of the conventional straining rate as specified in AS 1391.

Elongation results shall be reported on a gauge length  $L_0$  equal to  $5.65\sqrt{S_0}$ , where  $S_0$  is the original cross-sectional area of the test piece before testing. Conversion of results from a non-proportional gauge length shall be in accordance with ISO 2566-1.

For test pieces with cross-sectional area greater than  $1000 \text{ mm}^2$ , the minimum elongation after conversion to the gauge length of  $5.65\sqrt{S_0}$ , shall be reduced by 2% from that given in Table 8.

### 9.4.2 Impact test

#### 9.4.2.1 General

One test in accordance with AS 1544.2 shall be carried out on each of three test pieces prepared from each test sample specified in Clauses 9.1 and 9.2.

Impact test requirements shall comply with Clauses 9.4.2.2 or 9.4.2.3.

#### 9.4.2.2 Hollow sections with nominal thickness of 6 mm or greater

Impact tests shall be performed at  $0^\circ\text{C}$  in accordance with AS 1544.2.

#### 9.4.2.3 Hollow sections with nominal thickness less than 6 mm

Impact tests are not required at  $0^\circ\text{C}$  in accordance with AS 1544.2 subject to satisfying one or both of the following requirements:

- (a) The finished product using the same steel feed manufacturer, steel grade, steel processing for hollow sections complying with Clause 9.4.2.2.
- (b) The finished product ferrite grain size shall be greater than or equal to 6 as verified by the method specified in either AS 1733 or ISO 643, when the steel feed is aluminium killed. Alternatively, when aluminium is used as the grain-refining element, the grain size requirement shall be deemed to have been fulfilled if the cast analysis shows the aluminium content to be not less than 0.020% total aluminium, or alternatively, 0.015% soluble aluminium. In these cases, verification of the grain size shall not be required.

The above two methods of verification are only acceptable when confirmation of compliance with Clause 5 of this Standard is provided by the manufacturer or supplier.

### 9.4.3 Cold flattening test

The test piece shall be flattened at room temperature between two parallel plane surfaces with the weld seam located as follows in relation to the direction of flattening:

- (a) For  $d_0 \leq 60 \text{ mm}$ : 45 degrees.
- (b) For  $d_0 > 60 \text{ mm}$ : 90 degrees.

The test piece shall be flattened until the distance between the surfaces is  $0.75 d_0$  or less.

## 10 MECHANICAL PROPERTIES

### 10.1 Tensile test

When tested in accordance with Clause 9.4.1, the yield strength, tensile strength and elongation of the test piece shall conform to the limits given in Table 8 for the appropriate grade.

### 10.2 Impact test

For impact tests, carried out in accordance with Clause 9.4.2, the absorbed energy values shall conform to the limits given in Table 9.

### 10.3 Cold flattening test

When tested in accordance with Clause 9.4.3, a test piece taken from a circular section with a longitudinal weld seam shall show no signs of cracks or flaws. Superficial ruptures arising from surface defects shall not be cause for rejection.

**TABLE 7**  
**TENSILE TEST REQUIREMENTS**

Grade	Minimum yield strength MPa	Minimum tensile strength MPa	Minimum elongation as a proportion of the gauge length of $5.65\sqrt{S_0}$ (see Note) %					
			Circular hollow sections			Rectangular hollow sections		
			$d_0/t$			$b/t, d/t$		
			≤15	>15 ≤30	>30	≤15	>15 ≤30	>30
C250, C250L0	250	320	18	20	22	14	16	18
C350, C350L0	350	430	16	18	20	12	14	16
C450, C450L0	450	500	12	14	16	10	12	14

NOTE: These limits apply to the face from which the tensile test is taken. That is, for RHS, the use of  $b/t$  or  $d/t$  ratio is dependent on which face the test specimen is cut from. For SHS, there is only one ratio (as  $b = d$ ).

**TABLE 8**  
**CHARPY V-NOTCH IMPACT TEST REQUIREMENTS**

Grade	Test temperature °C	Minimum absorbed energy, J					
		Size of test piece					
		10 mm × 10 mm		10 mm × 7.5 mm		10 mm × 5 mm	
		Average of 3 tests	Individual test	Average of 3 tests	Individual test	Average of 3 tests	Individual test
C250L0 C350L0 C450L0	0	27	20	22	16	18	13

## 11 IDENTIFICATION, TEST AND INSPECTION CERTIFICATES

### 11.1 Identification

#### 11.1.1 Individual length markings

All hollow section lengths supplied to this Standard shall be clearly and legibly identified by suitable and durable methods, such as painting (e.g. ink jet) or stamping with the following:

- (a) The manufacturer's name or mark, or both.
- (b) The manufacturer's site or mill identification, or both.
- (c) Unique, traceable text identification, which shall be in either one or both of the following forms:
  - (i) The time and date of manufacture of the product.
  - (ii) A serialized identification number for quality control/assurance and traceability purposes.
- (d) The markings specified in Items (a), (b) and (c) shall be placed a minimum of once on each length of ex-mill tube.

Where identification is by means of die-stamping, low-stress stamps shall be used for impact tested grades.

#### NOTES:

- 1 Products not marked with the provisions specified in this Clause are non-compliant with this Standard.
- 2 If the identified portion of the product is subsequently removed, then these identifications are to be transferred to each remaining portion of the product.
- 3 Manufacturers making a statement of compliance with this Standard on a product, packaging or promotional material related to that product are advised to ensure that such compliance is capable of being verified.

#### 11.1.2 Bundle/pack markings

The material shall be marked or tagged for bundles with the following:

- (a) The manufacturer's name or mark, or both.
- (b) Reference to this Standard, i.e. AS/NZS 1163.
- (c) The grade of steel (see Clause 4).
- (d) The product dimensions to be identified with this Standard (see Appendix D for further details).
- (e) A traceable identification number.

### 11.2 Test and inspection certificates

#### 11.2.1 General

A test and inspection certificate shall be available to the purchaser for all products manufactured to this Standard for each batch produced.

#### 11.2.2 Transmission of test and inspection certificates by an intermediary

An intermediary shall only pass on either an original or a copy of the inspection documents provided by the manufacturer without any alteration except as noted below. This documentation shall be accompanied by suitable means of identification of the product, in order to ensure the traceability between the product and the documentation.



Copying of the original document is permitted, provided that—

- (a) traceability of product is maintained; and
- (b) the original manufacturer's document is available on request.

When producing copies of the original manufacturer's document, it is permissible to replace the original delivered quantity with the subsequent partial quantity.

NOTE: In the context of this Standard, an intermediary is a supplier and not a manufacturer (see Clauses 3.23 and 3.16 respectively).

### 11.2.3 *Qualifications on test and inspection certificates*

A test and inspection certificate shall provide the following:

- (a) Tests performed by a laboratory accredited by signatories to the International Laboratory Accreditation Corporation (ILAC) through their Mutual Recognition Arrangement (MRA) for the specific tests described in this Standard. The appropriate logo or further details of the ILAC (MRA) signatory shall be noted on the document.

NOTE: In Australia, ILAC (MRA) accredited bodies include National Association of Testing Authorities (NATA) and in New Zealand they include International Accreditation New Zealand (IANZ).

- (b) Additional tests as agreed between the purchaser and manufacturer.

NOTE: See Appendix A.

### 11.2.4 *Minimum requirements for test and inspection certificates*

All test and inspection certificates shall be in English alphanumeric characters, issued by the manufacturer, and include the following:

- (a) Manufacturer's name.
- (b) Test certificate number and test number.
- (c) Date of certification.
- (d) Product, testing specification and grade, e.g. AS/NZS 1163-C350L0 (see Clause 4).
- (e) Product dimensions and size, e.g. 200 × 100 × 5.0 RHS.  
NOTE: See Appendix D.
- (f) Product steelmaking process, e.g. basic oxygen continuously cast, fine-grained, fully killed steels, and the like (see Clause 5.1).
- (g) Length, bundle, pack or unique identifier to which the test certificate applies (see Clause 11.1).
- (h) Heat number (from steel feed casting).
- (i) For each test a laboratory identification providing traceability to the laboratory accreditation of the test type.
- (j) Chemical analysis type, e.g. ladle and cast analysis 'L' or product 'P' (see Clauses 6.2 and 6.3).
- (k) Chemical composition of carbon (C), silicon (Si), manganese (Mn), phosphorus (P), sulphur (S), chromium (Cr), molybdenum (Mo), aluminium (Al), titanium (Ti), niobium (Nb), vanadium (V), copper (Cu), nickel (Ni), boron (B), carbon equivalent (CE) and any other element intentionally added (see Clauses 6.1, 6.2, 6.3 and 6.4).
- (l) Where relevant, mechanical and other information as noted below:
  - (i) *Tensile tests to Clause 9.4.1* Orientation, i.e. longitudinal 'L' (see Clause 9.2.1), treatment, i.e. aged 'A' (see Clause 9.3.4) and results, i.e. yield strength in MPa, tensile strength in MPa and % elongation (see Clause 10.1).

- (ii) *Impact tests to Clause 9.4.2.2* Orientation, i.e. longitudinal 'L' (see Clause 9.2.1), treatment, i.e. aged 'A' (see Clause 9.3.4) and results (see Clause 10.2).
  - (iii) *Impact test reporting to Clause 9.4.2.3(a)* Statement of steel feed manufacturer name, grade/type, mill location, and other sizes with nominal thickness greater than or equal to 6 mm using the same steel feed type for compliance with Clause 9.4.2.2.
  - (iv) *Impact test reporting to Clause 9.4.2.3(b)* Statement of compliance with Clauses 5.1 and 9.4.2.3(b) with, where appropriate, further statements of finished product ferrite grain size, use of aluminium killed steel feed and/or aluminium content in total or soluble form.
- (m) The manufacturing facility's quality management system's certifier and certification number.
  - (n) The body assessing the product conformity to this Standard. For self-assessment this is the manufacturer, the default scheme is this Standard.
  - (o) A declaration from the manufacturer that the products supplied comply with the requirements of this Standard (refer to Clause 12) and Items (a) to (n) above. This shall be validated by the manufacturer's authorized inspection representative, including their name and position.

If the document has been validated by the purchaser's authorized representative or by an inspector designated by a third party, their name and position shall be on the document.

## **12 SAMPLING AND TESTING TO DEMONSTRATE PRODUCT CONFORMITY**

The minimum sampling and testing procedures shall conform to Appendix B. Additional testing may be agreed between the manufacturer and the purchaser.

## **13 ROUNDING OF NUMBERS**

### **13.1 General**

For the purpose of deciding whether a particular requirement of this Standard is complied with, the determined value, observed or calculated, shall be rounded off in accordance with AS 2706.

The number of significant places retained in the rounded-off values shall be the same as that of the specified value in this Standard.

### **13.2 Tensile properties**

The determined value of tensile strength shall be rounded off to the nearest 10 MPa and the determined value of yield strength shall be rounded off to the nearest 5 MPa.

## **14 MANIPULATION**

Requirements for cold-bending of galvanized circular hollow sections are given in Appendix C.

## **15 SECTION DESIGNATIONS, NOMINAL DIMENSIONS, CROSS-SECTION PROPERTIES AND MASSES**

Appendix D provides data on section designation, nominal section dimensions, cross-sections properties and mass.

APPENDIX A  
PURCHASING GUIDELINES  
(Informative)

## A1 GENERAL

Australian/New Zealand Standards are intended to include the technical provisions necessary for the supply of materials referred to in the particular Standard, but do not purport to comprise all the necessary provisions of a contract. The purchaser may specify additional requirements or be given a choice of optional requirements. These are contractual matters to be agreed upon between the purchaser and the manufacturer, or the supplier.

This Appendix contains detailed explanations, advice and recommendations on the information to be supplied by the purchaser at the time of enquiry and order.

The objective of this Appendix is to avoid misunderstandings and to result in the purchaser receiving satisfactory products and services.

## A2 INFORMATION TO BE SUPPLIED BY THE PURCHASER

The purchaser should consider and supply the following information at the time of order, after making due reference to the explanation, advice and recommendations contained in this Appendix:

- (a) Quantity and delivery instructions (dates, schedules, delivery point).
- (b) Dimensions of section, e.g. nominal length of long and short side, nominal outside diameter and nominal thickness (see Appendix D).
- (c) Designation of grade and Standard number (see Clause 4).
- (d) Any limitations in respect of packaging, e.g. number or sections per pack, packaging materials.
- (e) Whether a test certificate or test and/or inspection certificate is required (see Clause 11.2).
- (f) Whether documentation certifying the product conformity requirements (see Appendix B) is required.
- (g) Whether it is the intention of the purchaser to inspect the steel at the manufacturer's works (see Paragraph A3).
- (h) Any information concerning processing or end use that the purchaser considers would assist the manufacturer.
- (i) Whether a product analysis is required (see Clause 6.3).
- (j) Particular position of the weld seam (see Clause 8.2.1), if required.
- (k) Special mill finish or coating, e.g. galvanized.
- (l) End finish.
- (m) Whether special tolerances on dimensions are required.
- (n) Length of sections (including length tolerance type, see Table 7).
- (o) Zinc coating requirements. As a guide, recommendations for suitable chemistry of steels are provided in Clause 9.1 of AS/NZS 2312.2:2014.

Further information is available from the Galvanizers Association of Australia (GAA) and Galvanizing Association of New Zealand (GANZ).

NOTE: Any special or supplementary requirements of this Standard are to be subject to agreement between the purchaser and the manufacturer or the supplier at the time of enquiry and order, and should be stated on the order.

### **A3 INSPECTION**

If it is the purchaser's intention to undertake any of the following functions at the manufacturer's works, this should be notified at the time of order, and should be accomplished in a manner which will not interfere with the operation of the works. The functions are as follows:

- (a) Inspect the product during manufacture.
- (b) Select and identify the test samples.
- (c) Witness the tests being made.

The manufacturer should provide all reasonable facilities to enable the purchaser to be satisfied that the product complies with this Standard.

### **A4 HEAT TREATMENT**

The mechanical properties of these grades can be affected by any reheating that may be applied for its end use.

If it is intended to reheat these grades above 620°C, the purchaser should discuss the application and the proposed reheating treatment with the manufacturer.

NOTE: Welding to AS/NZS 1554 Parts 1, 2, 5 and 7 does not affect the mechanical properties of hollow sections manufactured to this Standard.

APPENDIX B  
PRODUCT CONFORMITY  
(Normative)

## **B1 SCOPE**

This Appendix sets out the means by which product conformity evaluation shall be demonstrated by the manufacturer or supplier by—

- (a) initial type testing; and
- (b) factory production control, including a minimum testing and inspection frequency plan.

Testing and inspection of one or two samples does not provide an acceptable representation of actual variability in a batch of unidentified steel.

NOTE: The result of testing and inspecting such a sample could fall within or outside the standard range by chance and does not present a valid picture of the characteristics being evaluated.

The product conformity requirements shall enable conformity assessment to be made by a manufacturer or supplier (first party), a user or purchaser (second party), or an independent body (third party), and shall not be dependent on a quality management systems Standard.

NOTE: An example of a quality management system Standard is AS/NZS ISO 9001.

## **B2 INITIAL TYPE TESTING**

### **B2.1 General**

An initial type testing program shall be carried out in accordance with Paragraph B2.2 under the sole responsibility of the manufacturer of the products before they are first placed onto the market.

Such a program shall be carried out in each case for grade designation with the highest strength and impact properties which a manufacturer places on the market. Additional programs are required for sections with lower strengths and higher impact property requirements.

Initial type testing shall be performed on first application of this Standard. Tests previously performed in accordance with the provisions of this Standard [same product, same characteristic(s) test method, sampling procedure, system of attestation of conformity, etc.] may be taken into account. In addition, the initial type testing shall be performed at the beginning of a new method of production, and/or using a new facility or equipment.

### **B2.2 Minimum sampling and testing plan**

The initial type testing and inspection program comprises of routine testing and inspection at a higher frequency to establish the capabilities of the manufacturing process to produce the steel product. Table B1 provides the minimum testing and inspection frequency plan for type testing. The results of all type tests shall conform to the requirements of this Standard.

**TABLE B1**  
**MINIMUM SAMPLING AND TESTING FREQUENCY PLAN**  
**FOR TYPE TESTS AND INSPECTIONS**

Characteristic	Clause	Requirement	Test Method	Frequency
Designation	4	Steel grade designation correct	Visual	Once
Manufacturing Process	5	Determine steel feed stock and steel making process	Records inspection, or initial supplier letter of compliance	Each heat
Chemical composition	6	Cast or product analysis and residual elements analysis	AS/NZS 1050.1 and analysis methods	Each heat, minimum of 5 produced after set-up*
Manufacturing tolerances	7	External dimensions	Gauging equipment	Each heat, minimum of 5 produced after set-up*
		Thickness		
		CHS out-of-roundness		
		RHS/SHS Concavity/convexity		
		RHS/SHS Squareness of sides		
		RHS/SHS External corner profile		
		RHS/SHS Twist		
		Straightness	Straight edge, String line and gauges	
Mass per unit length	Weighing equipment			
Freedom from defects	8.1	Free from laminations, surface flaws and other detrimental defects	Visual inspection	Each tensile test
	8.2.1	Weld seam position	Visual and	Each heat, minimum of 5 produced after set-up*
			Visual and/or Gauging equipment	
8.2.2	Weld seam defects	Visual inspection	Continuous	
Mechanical properties	9 and 10.1	Tensile strength, yield stress and elongation	To Clauses 9 and 10	6 tests for each heat for minimum 5 after set-up*
	9 and 10.2	Impact toughness		
	9 and 10.3	Cold flattening (CHS with OD $\leq 168.3$ mm only)		
Identification and certification	11.1.1	Individual length markings	Visual inspection	Each length, or bundle, minimum of 5 produced after set-up*
	11.1.2	Bundle pack markings		

\* Set-up is achieved after the manufacturing process is stable.

### B3 PRODUCTION TESTING AND INSPECTION

#### B3.1 Minimum batch testing and inspection

All products shall conform to the minimum frequency requirements of production testing as defined in Table B2.

**TABLE B2**  
**MINIMUM SAMPLING AND TESTING FREQUENCY PLAN**  
**FOR PRODUCTION TESTS AND INSPECTIONS**

Characteristic	Clause	Requirement	Test Method	Frequency
Manufacturing process	5	Determine steel feed stock and steel making process	Records inspection, or initial supplier letter of compliance or ongoing certification	Each heat
Chemical composition	6	Cast or product analysis and other elements analysis	AS/NZS 1050.1 and analysis methods	Each heat
Manufacturing tolerances	7	External dimensions	Gauging equipment	Once per hour*
		Thickness		
		CHS out-of-roundness		
		RHS/SHS Concavity/convexity		
		RHS/SHS Squareness of sides		
		RHS/SHS External corner profile		
		RHS/SHS Twist		
			Straightness	Straightedge, string line or gauges
		Mass per unit length	Weighing equipment	One test per size per day
Freedom from defects	8.1	Free from laminations, surface flaws and other detrimental defects	Visual inspection	Every tensile test
	8.2.1	Weld seam position	Visual	Continuous
			Gauging equipment	One test per batch
8.2.2	Weld seam defects	NDE	Visual—continuous	
Mechanical properties	9 and 10.1	Tensile strength, yield strength and elongation	To Clauses 9 and 10	Refer Notes
	9 and 10.2	Impact toughness		
	9 and 10.3	Cold flattening		One test per batch
Identification	11.1.1	Individual length markings	Visual inspection	Each hour*
	11.1.2	Bundle/pack markings		Each pack
Test and inspection certificates	11.2	Test and inspection certificates	Visual and records inspection	Each certificate

\* Time is operating hours.

NOTES:

- 1 For batch testing: The test sample frequencies for mechanical property testing shall be one sample for the first 50 tonnes of the batch and one additional test for every additional 50 tonnes or part thereof.
- 2 For statistical sampling, see Paragraph B3.2.

## B3.2 Statistical sampling

### B3.2.1 General

Process verification by statistical sampling or alternate methods can be used to demonstrate product conformity where the conditions required by these provisions are met (see also Note 1).

Where it can be demonstrated that the type test (see Note 2) of any group of products (see Note 3) manufactured under the same conditions of steel supplier, steel grade, steel processing and tube processing are distributed normally, then it shall be permissible to adopt statistical sampling to verify process acceptance for each product in accordance with ISO 7870-3.

For product conformance to this Standard via statistical sampling, the inputs of process acceptance verification, ongoing testing and statistical sampling must be demonstrated and, where applicable, also maintained. To ensure that the process being assessed is in control (see Note 1), a statistically significant number of samples needs to be obtained within a rationally determined time period that is reflective of typical manufacturing practice. Within a defined group, each type of test sample randomly selected shall not exceed a sampling period of three months.

Additionally, any sample or sampling that indicates a predicted proportion of nonconforming product in excess of an amount considered within the demonstrated statistical sampling method, shall cause the sampling for that combination of size, thickness and grade to revert to batch sampling rules until it can be demonstrated that the conditions of statistical sampling are valid for that combination.

In the event of actual nonconforming test results, the retest provisions of normal batch testing shall also apply.

#### NOTES:

- 1 Statistical sampling is a procedure that enables decisions to be made about the quality and conformity of batches of items after inspecting or testing only a portion of those items. This procedure will only be valid if the sampling plan has been determined on a statistical basis and the following are met:
  - (a) The sample is drawn randomly from a population of product of known history that enables verification that the product was made from known materials at essentially the same time by essentially the same processes and under essentially the same system of control.
  - (b) For each different situation, a suitable sampling plan is defined. A sampling plan for one manufacturer of given capability and product throughput may not be relevant to another manufacturer producing the same items.

In order for statistical sampling to be meaningful to the customer, the manufacturer or supplier needs to demonstrate how the above conditions have been satisfied. Sampling and the establishment of a sampling plan should be carried out in accordance with recognized Standards (e.g. AS 2490, AS 1199, Parts 0 and 1) and methods.

Under this approach, ongoing sampling and testing of product shall be directed primarily at monitoring the process to ensure that product outcomes are acceptable, within characteristic ranges as well as stable and under control (e.g. normally distributed).

- 2 The type test is the measured parameter such as tensile testing, impact testing, etc. These are long term testing plans based on initial testing undertaken to determine overall conformance and other required controls to be put into place (e.g. same steel supply, same manufacturing process) to ensure ongoing compliance.
- 3 To reduce sampling frequencies, a group of products can consist of an aggregation of batch data from a range of products if it can be demonstrated to be normally distributed.



### **B3.2.2** *Tensile tests*

#### **B3.2.2.1** *General*

Testing to AS 1391, as noted in Clause 9.4.1, is only considered within Paragraph B3.2.2 for product conformance assessment to tensile testing requirements.

#### **B3.2.2.2** *Sampling conditions*

In conjunction with the provisions of Paragraph B3.2.1, statistical sampling shall only be used for a combination of size, thickness and grade where the statistically predicted proportion of nonconforming product is less than 5% at a confidence level of 95%.

Changes in steel supplier, steel grade and significant changes in steel or tube processing (e.g. mill) shall necessitate a re-evaluation of the conditions in this Paragraph (B3.2.2.2).

### **B3.2.3** *Impact tests*

#### **B3.2.3.1** *General*

Testing and assessments to—

- (a) Clause 9.4.2.2;
- (b) Clause 9.4.2.3(a); and
- (c) the grain size provisions of Clause 9.4.2.3(b),

are only considered within Paragraph B3.2.3 for product conformance assessment to impact testing requirements.

#### **B3.2.3.2** *Sampling conditions*

In conjunction with the provisions of Paragraph B3.2.1, statistical sampling shall only be used for a combination of size, thickness and grade where the statistically predicted proportion of nonconforming product is less than 5% at a confidence level of 95%.

Changes in steel supplier or steel grade and significant changes in steel or tube processing shall necessitate a re-evaluation of the conditions in this Paragraph (B3.2.3.2).

## **B4** **FACTORY PRODUCTION CONTROL**

### **B4.1** **General**

The manufacturer shall establish, document and maintain a factory production control (FPC) system to ensure that the products placed on the market conform to the stated performance characteristics. The FPC system shall consist of procedures, regular inspections and tests and/or assessments and the use of the results to control raw and other incoming material or components, equipment, the production process and the product.

A quality management system covering the requirements of this Standard shall be considered to satisfy the requirements of an FPC.

NOTE: An example of an appropriate quality management system is AS/NZS ISO 9001.

### **B4.2** **Equipment**

#### **B4.2.1** *Testing*

All weighing, measuring and testing equipment shall be calibrated and regularly inspected according to documented procedures, frequencies and criteria.

#### **B4.2.2** *Manufacturing*

All equipment used in the manufacturing process shall be regularly inspected and maintained to ensure use, wear or failure does not cause inconsistency in the manufacturing process. Inspections and maintenance shall be carried out and recorded in accordance with the manufacturer's written procedures.

### **B4.3 Raw materials**

The specification of all incoming raw materials shall be documented, as shall the inspection scheme for ensuring their conformity. All manufacturing process and steel feed shall comply with the requirements of Clause 5.1.

### **B4.4 Product testing and evaluation**

The manufacturer shall establish procedures to ensure that the stated values of all the characteristics are maintained. The characteristics and the means of control shall be in accordance with the minimum requirements listed in Table B2.

## **B5 NONCONFORMING PRODUCTS**

### **B5.1 General**

The manufacturer shall have written procedures, specifying the processing of nonconforming product.

### **B5.2 Retests**

#### **B5.2.1 Tensile test and cold flattening test**

If a retest is carried out, one or more of the following procedures shall be adopted:

- (a) Make two additional tests on test pieces from test specimens taken from the same test sample at a position as near as practicable to the location of the failed test sample. The unit conforms to this Standard provided both additional test pieces conform to Clauses 9.2, 9.3, 9.4, 10.1 and 10.3.
- (b) Make two test samples at random from the remainder of the batch. If the test pieces from both additional samples conform to Clauses 9.2, 9.3, 9.4, 10.1 and 10.3, the remainder of the batch conforms to this Standard. If one of these test samples fails to conform, the steel of the applicable batch does not conform to this Standard.
- (c) Make test samples from each rolled unit of steel and individually test in accordance with this Standard. If the test piece from the additional sample conforms, to Clauses 9.2, 9.3, 9.4, 10.1 and 10.3, the rolled unit of steel conforms to this Standard.

#### **B5.2.2 Impact tests**

If a retest is carried out, one or more of the following procedures shall be adopted:

- (a) If the average value of the three impact test results is less than the specified minimum average, or if one value is less than the specified individual test value given in Table 9, then test three additional test pieces from the original test sample in accordance with Clauses 9.2, 9.3 and 9.4, and add the results to those previously obtained and calculate a new average.

If the average value of the six tests is not less than the specified minimum average, and not more than one result of the six tests is below the minimum specified individual test value given in Table 9, then the unit conforms to this Standard.

- (b) Take two further test samples at random from the remainder of the test batch. If the test pieces from both additional samples conform to Clauses 9.2, 9.3, 9.4 and 10.2, then the remainder of the test batch conforms to this Standard. If one of these additional samples fails to conform, the steel of the applicable batch does not conform to this Standard.
- (c) Take test samples from each rolled unit of steel and individually test in accordance with this Standard. If the test piece from the additional sample conforms to Clauses 9.2, 9.3, 9.4 and 10.2, then the rolled unit of steel conforms to this Standard.

**B5.3 Repair**

All repaired product shall be inspected and meet the requirements of this Standard.

**B6 DOCUMENTATION**

The results of all testing programs shall be recorded and such records shall be maintained and be made available for inspection for a period of at least 5 years after the date when that last product to which the test program refers to was delivered. Results for initial type testing shall be maintained for the period of manufacture of the product.

Documentation shall include information to be supplied to the purchaser, plus manufacturing process, physical and mechanical properties, inspection and testing, and test procedures.

APPENDIX C  
MANIPULATION

(Normative)

Galvanized circular hollow sections of outside diameter  $\leq 60.3$  mm and other shaped hollow sections of equivalent dimensions, shall be capable of withstanding a  $90^\circ$  bend around a grooved mandrel having a root radius of 6 times the outside diameter of the circular hollow sections or the section dimension in the plane of the bend for non-circular hollow sections. On completion of the bending operation, the galvanized coating shall show no signs of cracks or flaws.

APPENDIX D  
SECTION DESIGNATIONS, DIMENSIONS AND CROSS-SECTION  
PROPERTIES

(Normative)

This Appendix provides lists of common cold-formed structural steel hollow sections (SSHS) available in Australia and New Zealand. The lists provide their section designation, respective nominal dimensions, cross-section properties and mass.

NOTE: Although they appear in the following tables, certain sizes may not always be available in all grades. Users are advised to check availability before incorporating hollow sections in major designs.

The formulae for calculating sectional properties of sections manufactured to the dimensional tolerances of this Standard, to be used for the purposes of structural design and also listed in this Appendix, are specified in Appendix E.

Figures D1 to D4 are not restrictive nor exhaustive. Other SSHS shapes and sizes with different designations and dimensions may be produced to this Standard. Manufacturers shall provide the designation, nominal dimensions, cross-sectional properties and mass for SSHS produced that are not listed in Figures D1 to D4.

Where CHS, RHS and SHS are not listed in this Appendix, Appendix E shall be used to evaluate cross-sectional properties and mass.

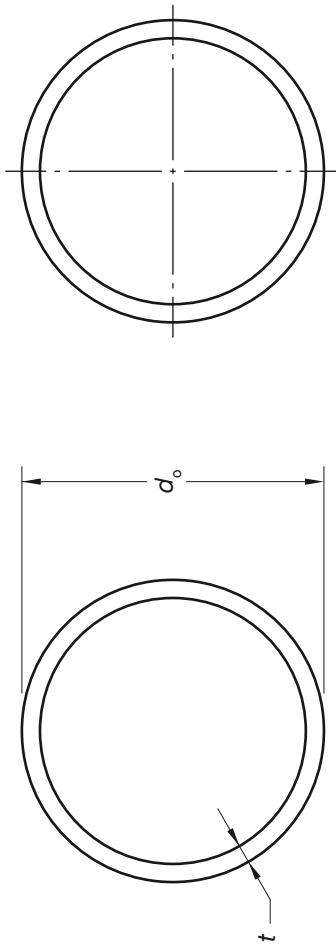

1	Designation	2	3	4		5	6	7	8			10	11	12
				External surface area					About any axis					
Outside diameter	Thickness	Mass per unit length	Per unit length	Per unit mass	Ratio	Gross area of cross-section	Second moment of area	Elastic section modulus	Plastic section modulus	Torsion constant	Torsion modulus			
$d_o$	$t$	$m$	$A_{EL}$	$A_{EM}$	$\frac{d_o}{t}$	$A_g$	$I$	$Z$	$S$	$J$	$C$			
mm	mm	kg/m	$m^2/m$	$m^2/t$		$mm^2$	$10^6 mm^4$	$10^3 mm^3$	$10^3 mm^3$	$10^6 mm^4$	$10^3 mm^3$			
610.0	× 12.7 CHS	187	1.92	10.2	48.0	23800	1060	3490	4530	2130	6970			
610.0	× 9.5 CHS	141	1.92	13.6	64.2	17900	808	2650	3430	1620	5300			
610.0	× 6.4 CHS	95.3	1.92	20.1	95.3	12100	553	1810	2330	1110	3620			
508.0	× 12.7 CHS	155	1.60	10.3	40.0	19800	606	2390	3120	1210	4770			
508.0	× 9.5 CHS	117	1.60	13.7	53.5	14900	462	1820	2360	925	3640			
508.0	× 6.4 CHS	79.2	1.60	20.2	79.4	10100	317	1250	1610	634	2500			
165.1	× 5.4 CHS	21.3	0.519	24.4	30.6	2710	8.65	105	138	17.3	209			
165.1	× 5.0 CHS	19.7	0.519	26.3	33.0	2510	8.07	97.7	128	16.1	195			

FIGURE D1 (in part) CIRCULAR HOLLOW SECTIONS (see also Figure D2 for other CHS listings)

1		2		3		4		5		6		7		8		9		10		11		12	
Designation		Mass per unit length		External surface area		Ratio		Gross area of cross-section		Second moment of area		About any axis		Elastic section modulus		Plastic section modulus		Radius of gyration		Torsion constant		Torsion modulus	
Outside diameter	Thickness			Per unit length	Per unit mass																		
$d_o$	$t$	$m$	$A_{EL}$	$A_{EM}$	$\frac{d_o}{t}$	$A_g$	$I$	$Z$	$S$	$r$	$J$	$C$											
mm	mm	kg/m	m <sup>2</sup> /m	m <sup>2</sup> /t		mm <sup>2</sup>	10 <sup>6</sup> mm <sup>4</sup>	10 <sup>3</sup> mm <sup>3</sup>	10 <sup>3</sup> mm <sup>3</sup>	mm	10 <sup>6</sup> mm <sup>4</sup>	10 <sup>3</sup> mm <sup>3</sup>											
139.7	× 5.4 CHS	17.9	0.439	24.5	25.9	2280	5.14	73.7	97.4	47.5	10.3	147											
139.7	× 5.0 CHS	16.6	0.439	26.4	27.9	2120	4.81	68.8	90.8	47.7	9.61	138											
114.3	× 5.4 CHS	14.5	0.359	24.8	21.2	1850	2.75	48.0	64.1	38.5	5.49	96.1											
114.3	× 4.5 CHS	12.2	0.359	29.5	25.4	1550	2.34	41.0	54.3	38.9	4.69	82.0											
101.6	× 5.0 CHS	11.9	0.319	26.8	20.3	1520	1.77	34.9	46.7	34.2	3.55	69.9											
101.6	× 4.0 CHS	9.63	0.319	33.2	25.4	1230	1.46	28.8	38.1	34.5	2.93	57.6											
88.9	× 5.9 CHS	12.1	0.279	23.1	15.1	1540	1.33	30.0	40.7	29.4	2.66	59.9											
88.9	× 5.0 CHS	10.3	0.279	27.0	17.8	1320	1.16	26.2	35.2	29.7	2.33	52.4											
88.9	× 4.0 CHS	8.38	0.279	33.3	22.2	1070	0.963	21.7	28.9	30.0	1.93	43.3											
76.1	× 5.9 CHS	10.2	0.239	23.4	12.9	1300	0.807	21.2	29.1	24.9	1.61	42.4											
76.1	× 4.5 CHS	7.95	0.239	30.1	16.9	1010	0.651	17.1	23.1	25.4	1.30	34.2											
76.1	× 3.6 CHS	6.44	0.239	37.1	21.1	820	0.540	14.21	8.9	25.7	1.08	28.4											
60.3	× 5.4 CHS	7.31	0.189	25.9	11.2	931	0.354	11.8	16.3	19.5	0.709	23.5											
60.3	× 4.5 CHS	6.19	0.189	30.6	13.4	789	0.309	10.2	14.0	19.8	0.618	20.5											
60.3	× 3.6 CHS	5.03	0.189	37.6	16.8	641	0.259	8.58	11.6	20.1	0.517	17.2											
48.3	× 5.4 CHS	5.71	0.152	26.6	8.9	728	0.170	7.04	9.99	15.3	0.340	14.1											
48.3	× 4.0 CHS	4.37	0.152	34.7	12.1	557	0.138	5.70	7.87	15.7	0.275	11.4											
48.3	× 3.2 CHS	3.56	0.152	42.6	15.1	453	0.116	4.80	6.52	16.0	0.232	9.59											
42.4	× 4.9 CHS	4.53	0.133	29.4	8.7	577	0.103	4.87	6.93	13.4	0.206	9.74											
42.4	× 4.0 CHS	3.79	0.133	35.2	10.6	483	0.0899	4.24	5.92	13.6	0.180	8.48											
42.4	× 3.2 CHS	3.09	0.133	43.1	13.3	394	0.0762	3.59	4.93	13.9	0.152	7.19											

FIGURE D1 (in part) CIRCULAR HOLLOW SECTIONS (see also Figure D2 for other CHS listings)

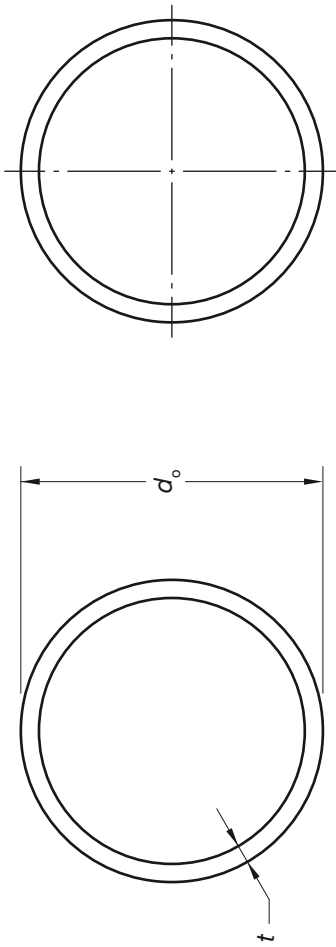

1	Designation	2		3		4	5	6	7	8			10	11	12
		Mass per unit length	m	External surface area						Ratio	Gross area of cross-section	Second moment of area			
kg/m	Per unit length			Per unit mass	$A_{EL}$	$A_{EM}$	$\frac{d_o}{t}$	$A_g$	$I$				Elastic section modulus	Plastic section modulus	Torsion constant
$d_o$	$\times$	$t$	$m$	$A_{EL}$	$A_{EM}$	$\frac{d_o}{t}$	$A_g$	$I$	Z	S	J	C			
mm	$\times$	mm	kg/m	$m^2/m$	$m^2/t$		$mm^2$	$10^6 mm^4$	$10^3 mm^3$	$10^3 mm^3$	$10^6 mm^4$	$10^3 mm^3$	$10^6 mm^4$	$10^3 mm^3$	
457.0	$\times$	12.7 CHS	139	1.44	10.3	36.0	17700	438	1920	2510	876	3830			
457.0	$\times$	9.5 CHS	105	1.44	13.7	48.1	13400	334	1460	1900	669	2930			
457.0	$\times$	6.4 CHS	71.1	1.44	20.2	71.4	9060	230	1010	1300	460	2010			
406.4	$\times$	12.7 CHS	123	1.28	10.4	32.0	15700	305	1500	1970	609	3000			
406.4	$\times$	9.5 CHS	93.0	1.28	13.7	42.8	11800	233	1150	1500	467	2300			
406.4	$\times$	6.4 CHS	63.1	1.28	20.2	63.5	8040	161	792	1020	322	1580			
355.6	$\times$	12.7 CHS	107	1.12	10.4	28.0	13700	201	1130	1490	403	2260			
355.6	$\times$	9.5 CHS	81.1	1.12	13.8	37.4	10300	155	871	1140	310	1740			
355.6	$\times$	6.4 CHS	55.1	1.12	20.3	55.6	7020	107	602	781	214	1200			
323.9	$\times$	2.7 CHS	97.5	1.02	10.4	25.5	12400	151	930	1230	301	1860			
323.9	$\times$	9.5 CHS	73.7	1.02	13.8	34.1	9380	116	717	939	232	1430			
323.9	$\times$	6.4 CHS	50.1	1.02	20.3	50.6	6380	80.5	497	645	161	994			

FIGURE D2 (in part) CIRCULAR HOLLOW SECTIONS (see also Figure D1 for other CHS listings)



1		2		3		4		5		6		7		8		9		10		11		12	
Designation		Mass per unit length		External surface area		Gross area of cross-section		Second moment of area		Elastic section modulus		Plastic section modulus		Radius of gyration		Torsion constant		Torsion modulus					
Outside diameter	Thickness	Per unit length	Per unit mass	$A_{EL}$	$A_{EM}$	Ratio	$A_g$	$I$	$Z$	$S$	$r$	$J$	$C$										
$d_o$	$t$	$m$	$A_{EM}$	$A_{EL}$	$A_{EM}$	$\frac{d_o}{t}$	$A_g$	$I$	$Z$	$S$	$r$	$J$	$C$										
mm	mm	kg/m	m <sup>2</sup> /t	m <sup>2</sup> /m	m <sup>2</sup> /t		mm <sup>2</sup>	10 <sup>6</sup> mm <sup>4</sup>	10 <sup>3</sup> mm <sup>3</sup>	10 <sup>3</sup> mm <sup>3</sup>	mm	10 <sup>6</sup> mm <sup>4</sup>	10 <sup>3</sup> mm <sup>3</sup>										
273.1	× 9.3 CHS	60.5	14.2	0.858	14.2	29.4	7710	67.1	492	647	93.3	134	983										
273.1	× 6.4 CHS	42.1	20.4	0.858	20.4	42.7	5360	47.7	349	455	94.3	95.4	699										
273.1	× 4.8 CHS	31.8	27.0	0.858	27.0	56.9	4050	36.4	267	346	94.9	72.8	533										
219.1	× 8.2 CHS	42.6	16.1	0.688	16.1	26.7	5430	30.3	276	365	74.6	60.5	552										
219.1	× 6.4 CHS	33.6	20.5	0.688	20.5	34.2	4280	24.2	221	290	75.2	48.4	442										
219.1	× 4.8 CHS	25.4	27.1	0.688	27.1	45.6	3230	18.6	169	220	75.8	37.1	339										
168.3	× 7.1 CHS	28.2	18.7	0.529	18.7	23.7	3600	11.7	139	185	57.0	23.4	278										
168.3	× 6.4 CHS	25.6	20.7	0.529	20.7	26.3	3260	10.7	127	168	57.3	21.4	254										
168.3	× 4.8 CHS	19.4	27.3	0.529	27.3	35.1	2470	8.25	98.0	128	57.8	16.5	196										
165.1	× 3.5 CHS	13.9	37.2	0.519	37.2	47.2	1780	5.80	70.3	91.4	57.1	11.6	141										
165.1	× 3.0 CHS	12.0	43.2	0.519	43.2	55.0	1530	5.02	60.8	78.8	57.3	10.0	122										
139.7	× 3.5 CHS	11.8	37.3	0.439	37.3	39.9	1500	3.47	49.7	64.9	48.2	6.95	99.5										
139.7	× 3.0 CHS	10.1	43.4	0.439	43.4	46.6	1290	3.01	43.1	56.1	48.3	6.02	86.2										
114.3	× 6.0 CHS	16.0	22.4	0.359	22.4	19.1	2040	3.00	52.5	70.4	38.3	6.00	105										
114.3	× 4.8 CHS	13.0	27.7	0.359	27.7	23.8	1650	2.48	43.4	57.6	38.8	4.96	86.8										
114.3	× 3.6 CHS	9.83	36.5	0.359	36.5	31.8	1250	1.92	33.6	44.1	39.2	3.84	67.2										
114.3	× 3.2 CHS	8.77	41.0	0.359	41.0	35.7	1120	1.72	30.2	39.5	39.3	3.45	60.4										
101.6	× 3.2 CHS	7.77	41.1	0.319	41.1	31.8	989	1.20	23.6	31.0	34.8	2.40	47.2										
101.6	× 2.6 CHS	6.35	50.3	0.319	50.3	39.1	809	0.991	19.5	25.5	35.0	1.98	39.0										
88.9	× 5.5 CHS	11.3	24.7	0.279	24.7	16.2	1440	1.26	28.3	38.3	29.6	2.52	56.6										
88.9	× 4.8 CHS	9.96	28.1	0.279	28.1	18.5	1270	1.12	25.3	34.0	29.8	2.25	50.6										
88.9	× 3.2 CHS	6.76	41.3	0.279	41.3	27.8	862	0.792	17.8	23.5	30.3	1.58	35.6										
88.9	× 2.6 CHS	5.53	50.5	0.279	50.5	34.2	705	0.657	14.8	19.4	30.5	1.31	29.6										
76.1	× 3.2 CHS	5.75	41.6	0.239	41.6	23.8	733	0.488	12.8	17.0	25.8	0.976	25.6										
76.1	× 2.3 CHS	4.19	57.1	0.239	57.1	33.1	533	0.363	9.55	12.5	26.1	0.727	19.1										

FIGURE D2 (in part) CIRCULAR HOLLOW SECTIONS (see also Figure D1 for other CHS listings)



1		2		3		4		5		6		7		8		9		10		11		12		13		14		15		16		17		
Designation		Mass per unit length		External surface area		Ratio		Gross area of cross-section		About x-axis		About y-axis		Second moment of area		Elastic modulus		Plastic modulus		Radius of gyration		Second moment of area		Elastic modulus		Plastic modulus		Radius of gyration		Torsion constant		Torsion modulus		
Depth	Width	Thickness	$m$	Per unit length	Per unit mass	$\frac{b-2t}{t}$	$\frac{d-2t}{t}$	$A_g$	$I_x$	$Z_x$	$S_x$	$r_x$	$I_y$	$Z_y$	$S_y$	$r_y$	$I_x$	$Z_x$	$S_x$	$r_x$	$I_y$	$Z_y$	$S_y$	$r_y$	$I_x$	$Z_x$	$S_x$	$r_x$	$I_y$	$Z_y$	$S_y$	$r_y$	$J$	$C$
$d$	$x$	$b$	$x$	$t$	$m$	$A_{EL}$	$A_{EM}$	$m^2/m$	$m^2/t$	$mm^2$	$10^6 mm^4$	$10^3 mm^3$	$10^6 mm^4$	$10^3 mm^3$	$10^3 mm^3$	$mm$	$10^6 mm^4$	$10^3 mm^3$	$10^3 mm^3$	$mm$	$10^6 mm^4$	$10^3 mm^3$	$10^3 mm^3$	$mm$	$10^6 mm^4$	$10^3 mm^3$	$10^3 mm^3$	$mm$	$10^6 mm^4$	$10^3 mm^3$	$10^3 mm^3$	$mm$	$10^6 mm^4$	$10^3 mm^3$
100	x	50	x	6.0	RHS	0.274	22.8	0.274	22.8	1530	1.71	34.2	0.567	22.7	27.7	19.2	0.567	22.7	45.3	33.4	0.567	22.7	27.7	19.2	0.567	22.7	45.3	33.4	0.567	22.7	27.7	19.2	1.53	40.9
100	x	50	x	5.0	RHS	0.279	27.0	0.279	27.0	1310	1.53	30.6	0.511	20.4	24.4	19.7	0.511	20.4	39.8	34.1	0.511	20.4	24.4	19.7	0.511	20.4	39.8	34.1	0.511	20.4	24.4	19.7	1.35	36.5
100	x	50	x	4.0	RHS	0.283	33.3	0.283	33.3	1080	1.31	26.1	0.441	17.6	20.6	20.2	0.441	17.6	33.4	34.8	0.441	17.6	20.6	20.2	0.441	17.6	33.4	34.8	0.441	17.6	20.6	20.2	1.13	31.2
100	x	50	x	3.5	RHS	0.285	37.9	0.285	37.9	959	1.18	23.6	0.400	16.0	18.5	20.4	0.400	16.0	29.9	35.1	0.400	16.0	18.5	20.4	0.400	16.0	29.9	35.1	0.400	16.0	18.5	20.4	1.01	28.2
100	x	50	x	3.0	RHS	0.290	43.9	0.290	43.9	841	1.06	21.3	0.361	14.4	16.4	20.7	0.361	14.4	26.7	35.6	0.361	14.4	16.4	20.7	0.361	14.4	26.7	35.6	0.361	14.4	16.4	20.7	0.886	25.0
100	x	50	x	2.5	RHS	0.291	52.4	0.291	52.4	709	0.912	18.2	0.311	12.4	14.0	20.9	0.311	12.4	22.7	35.9	0.311	12.4	14.0	20.9	0.311	12.4	22.7	35.9	0.311	12.4	14.0	20.9	0.754	21.5
100	x	50	x	2.0	RHS	0.293	65.1	0.293	65.1	574	0.750	15.0	0.257	10.3	11.5	21.2	0.257	10.3	18.5	36.2	0.257	10.3	11.5	21.2	0.257	10.3	18.5	36.2	0.257	10.3	11.5	21.2	0.616	17.7
75	x	50	x	4.0	RHS	0.233	33.7	0.233	33.7	881	0.630	16.8	0.335	13.4	16.0	19.5	0.335	13.4	21.1	26.7	0.335	13.4	16.0	19.5	0.335	13.4	21.1	26.7	0.335	13.4	16.0	19.5	0.754	22.7
75	x	50	x	3.0	RHS	0.240	44.2	0.240	44.2	691	0.522	13.9	0.278	11.1	12.9	20.0	0.278	11.1	17.1	27.5	0.278	11.1	12.9	20.0	0.278	11.1	17.1	27.5	0.278	11.1	12.9	20.0	0.593	18.4
75	x	50	x	2.5	RHS	0.241	52.7	0.241	52.7	584	0.450	12.0	0.240	9.60	11.0	20.3	0.240	9.60	14.6	27.7	0.240	9.60	11.0	20.3	0.240	9.60	14.6	27.7	0.240	9.60	11.0	20.3	0.505	15.9
75	x	50	x	2.0	RHS	0.243	65.4	0.243	65.4	474	0.372	9.91	0.199	7.96	9.06	20.5	0.199	7.96	12.0	28.0	0.199	7.96	9.06	20.5	0.199	7.96	12.0	28.0	0.199	7.96	9.06	20.5	0.414	13.1
75	x	25	x	2.5	RHS	0.191	53.1	0.191	53.1	459	0.285	7.60	0.0487	3.89	4.53	10.3	0.0487	3.89	10.1	24.9	0.0487	3.89	4.53	10.3	0.0487	3.89	10.1	24.9	0.0487	3.89	4.53	10.3	0.144	7.14
75	x	25	x	2.0	RHS	0.193	65.8	0.193	65.8	374	0.238	6.36	0.0414	3.31	3.77	10.5	0.0414	3.31	8.31	25.3	0.0414	3.31	3.77	10.5	0.0414	3.31	8.31	25.3	0.0414	3.31	3.77	10.5	0.120	6.04
75	x	25	x	1.6	RHS	0.195	81.7	0.195	81.7	303	0.197	5.26	0.0347	2.78	3.11	10.7	0.0347	2.78	6.81	25.5	0.0347	2.78	3.11	10.7	0.0347	2.78	6.81	25.5	0.0347	2.78	3.11	10.7	0.0993	5.05
65	x	35	x	3.0	RHS	0.190	44.7	0.190	44.7	541	0.281	8.65	0.106	6.04	7.11	14.0	0.106	6.04	11.0	22.8	0.106	6.04	7.11	14.0	0.106	6.04	11.0	22.8	0.106	6.04	7.11	14.0	0.259	10.4
65	x	35	x	2.5	RHS	0.191	53.1	0.191	53.1	459	0.244	7.52	0.0926	5.29	6.13	14.2	0.0926	5.29	9.45	23.1	0.0926	5.29	6.13	14.2	0.0926	5.29	9.45	23.1	0.0926	5.29	6.13	14.2	0.223	9.10
65	x	35	x	2.0	RHS	0.193	65.8	0.193	65.8	374	0.204	6.28	0.0778	4.44	5.07	14.4	0.0778	4.44	7.80	23.4	0.0778	4.44	5.07	14.4	0.0778	4.44	7.80	23.4	0.0778	4.44	5.07	14.4	0.184	7.62
50	x	25	x	3.0	RHS	0.140	45.5	0.140	45.5	391	0.112	4.47	0.0367	2.93	3.56	9.69	0.0367	2.93	5.86	16.9	0.0367	2.93	3.56	9.69	0.0367	2.93	5.86	16.9	0.0367	2.93	3.56	9.69	0.0964	5.18
50	x	25	x	2.5	RHS	0.141	54.0	0.141	54.0	334	0.0989	3.95	0.0328	2.62	3.12	9.91	0.0328	2.62	5.11	17.2	0.0328	2.62	3.12	9.91	0.0328	2.62	5.11	17.2	0.0328	2.62	3.12	9.91	0.0843	4.60
50	x	25	x	2.0	RHS	0.143	66.6	0.143	66.6	274	0.0838	3.35	0.0281	2.25	2.62	10.1	0.0281	2.25	4.26	17.5	0.0281	2.25	2.62	10.1	0.0281	2.25	4.26	17.5	0.0281	2.25	2.62	10.1	0.0706	3.92
50	x	25	x	1.6	RHS	0.145	82.5	0.145	82.5	223	0.0702	2.81	0.0237	1.90	2.17	10.3	0.0237	1.90	3.53	17.7	0.0237	1.90	2.17	10.3	0.0237	1.90	3.53	17.7	0.0237	1.90	2.17	10.3	0.0585	3.29
50	x	20	x	3.0	RHS	0.130	45.8	0.130	45.8	361	0.0951	3.81	0.0212	2.12	2.63	7.67	0.0212	2.12	5.16	16.2	0.0212	2.12	2.63	7.67	0.0212	2.12	5.16	16.2	0.0212	2.12	2.63	7.67	0.0620	3.88
50	x	20	x	2.5	RHS	0.131	54.2	0.131	54.2	309	0.0848	3.39	0.0192	1.92	2.32	7.89	0.0192	1.92	4.51	16.6	0.0192	1.92	2.32	7.89	0.0192	1.92	4.51	16.6	0.0192	1.92	2.32	7.89	0.0550	3.49
50	x	20	x	2.0	RHS	0.133	66.8	0.133	66.8	254	0.0723	2.89	0.0167	1.67	1.96	8.11	0.0167	1.67	3.78	16.9	0.0167	1.67	1.96	8.11	0.0167	1.67	3.78	16.9	0.0167	1.67	1.96	8.11	0.0466	3.00
50	x	20	x	1.6	RHS	0.135	82.7	0.135	82.7	207	0.0608	2.43	0.0142	1.42	1.63	8.29	0.0142	1.42	3.14	17.1	0.0142	1.42	1.63	8.29	0.0142	1.42	3.14	17.1	0.0142	1.42	1.63	8.29	0.0389	2.55

NOTE: The calculation of sectional properties is based on the following corner geometry:

Size range	Inside corner radius mm	Outside corner radius mm
Thickness 3.0 mm and less	1.0t	2.0t
Thickness greater than 3.0 mm	1.5t	2.5t

FIGURE D3 (in part) RECTANGULAR HOLLOW SECTIONS

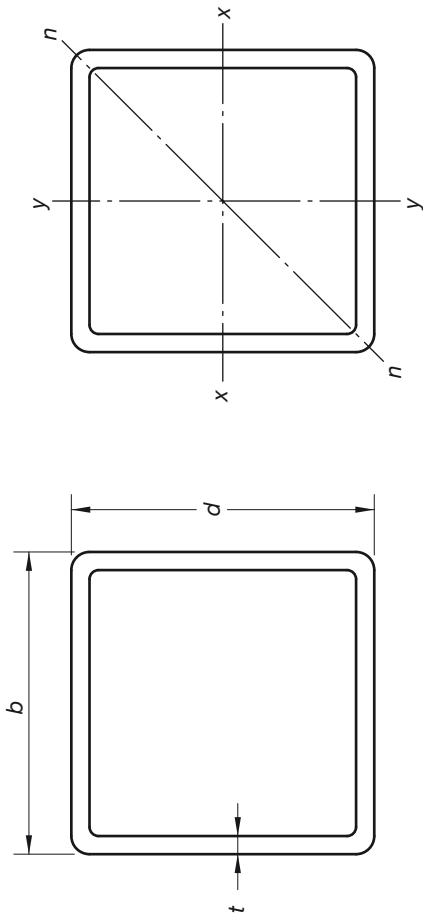

1 Designation	2 Mass per unit length <i>m</i> kg/m	3 External surface area		5 Ratio $\frac{b - 2t}{t}$	6 Gross area of cross-section <i>A<sub>g</sub></i> mm <sup>2</sup>	8 About <i>x</i> , <i>y</i> and <i>n</i> - axes				11 Radius of gyration <i>r<sub>x</sub></i> , <i>r<sub>y</sub></i> mm	12 Torsion constant modulus <i>J</i> 10 <sup>6</sup> mm <sup>4</sup>	13 Torsion modulus <i>C</i> 10 <sup>3</sup> mm <sup>3</sup>	
		Per unit length <i>A<sub>EL</sub></i> m <sup>2</sup> /m	Per unit mass <i>A<sub>EM</sub></i> m <sup>2</sup> /t			7 Second moment of area <i>I<sub>x</sub></i> , <i>I<sub>y</sub></i> 10 <sup>6</sup> mm <sup>4</sup>	8 Elastic section modulus <i>Z<sub>x</sub></i> , <i>Z<sub>y</sub></i> 10 <sup>3</sup> mm <sup>3</sup>	9 Elastic section modulus <i>Z<sub>n</sub></i> 10 <sup>3</sup> mm <sup>3</sup>	10 Plastic section modulus <i>S<sub>x</sub></i> , <i>S<sub>y</sub></i> 10 <sup>3</sup> mm <sup>3</sup>				
<i>b</i> × <i>b</i> × <i>t</i> mm × mm × mm													
250 × 250 × 9.0 SHS	65.9	0.961	14.6	25.8	8400	79.8	639	477	750	97.5	129	972	
250 × 250 × 6.0 SHS	45.0	0.974	21.7	39.7	5730	56.2	450	330	521	99.0	88.7	681	
200 × 200 × 9.0 SHS	51.8	0.761	14.7	20.2	6600	39.2	392	297	465	77.1	64.5	599	
200 × 200 × 6.0 SHS	35.6	0.774	21.8	31.3	4530	28.0	280	207	327	78.6	44.8	425	
200 × 200 × 5.0 SHS	29.9	0.779	26.0	38.0	3810	23.9	239	175	277	79.1	37.8	362	
150 × 150 × 9.0 SHS	37.7	0.561	14.9	14.7	4800	15.4	205	159	248	56.6	26.1	316	
150 × 150 × 6.0 SHS	26.2	0.574	22.0	23.0	3330	11.3	150	113	178	58.2	18.4	229	
150 × 150 × 5.0 SHS	22.1	0.579	26.2	28.0	2810	9.70	129	96.1	151	58.7	15.6	197	
125 × 125 × 9.0 SHS	30.6	0.461	15.1	11.9	3900	8.38	134	106	165	46.4	14.5	208	
125 × 125 × 6.0 SHS	21.4	0.474	22.1	18.8	2730	6.29	101	76.5	120	48.0	10.4	154	
125 × 125 × 5.0 SHS	18.2	0.479	26.3	23.0	2310	5.44	87.1	65.4	103	48.5	8.87	133	
125 × 125 × 4.0 SHS	14.8	0.483	32.7	29.3	1880	4.52	72.3	53.6	84.5	49.0	7.25	110	

FIGURE D4 (in part) SQUARE HOLLOW SECTIONS

1		2		3		4		5		6		7		8		9		10		11		12		13	
Designation		Mass per unit length		External surface area		Ratio		Gross area of cross-section		Second moment of area		Elastic section modulus		Elastic section modulus		Plastic section modulus		Radius of gyration		Torsion constant		Torsion modulus			
																								Per unit length	
Depth	Width	Thickness	$m$	$A_{EL}$	$A_{EM}$	$\frac{b-2t}{t}$	$A_g$	$I_x, I_y$	$Z_x, Z_y$	$Z_n$	$S_x, S_y$	$r_x, r_y$	$J$	$C$											
$b \times$	$b \times$	$t$	kg/m	$m^2/m$	$m^2/t$		$mm^2$	$10^6 mm^4$	$10^3 mm^3$	$10^3 mm^3$	$10^3 mm^3$	mm	$10^6 mm^4$	$10^3 mm^3$											
100 x 100	x	9.0 SHS	23.5	0.361	15.4	9.11	3000	3.91	78.1	63.6	98.6	36.1	7.00	123											
100 x 100	x	6.0 SHS	16.7	0.374	22.4	14.7	2130	3.04	60.7	47.1	73.5	37.7	5.15	93.6											
100 x 100	x	5.0 SHS	14.2	0.379	26.6	18.0	1810	2.66	53.1	40.5	63.5	38.3	4.42	81.4											
100 x 100	x	4.0 SHS	11.6	0.383	32.9	23.0	1480	2.23	44.6	33.5	52.6	38.8	3.63	68.0											
100 x 100	x	3.0 SHS	8.96	0.390	43.5	31.3	1140	1.77	35.4	26.0	41.2	39.4	2.79	53.2											
89 x 89	x	6.0 SHS	14.6	0.330	22.5	12.8	1870	2.06	46.2	36.3	56.6	33.2	3.54	71.6											
89 x 89	x	5.0 SHS	12.5	0.334	26.7	15.8	1590	1.81	40.7	31.4	49.1	33.7	3.05	62.7											
89 x 89	x	3.5 SHS	9.06	0.341	37.6	23.4	1150	1.37	30.9	23.2	36.5	34.5	2.24	47.1											
75 x 75	x	6.0 SHS	12.0	0.274	22.8	10.5	1530	1.16	30.9	24.7	38.4	27.5	2.04	48.2											
75 x 75	x	5.0 SHS	10.3	0.279	27.0	13.0	1310	1.03	27.5	21.6	33.6	28.0	1.77	42.6											
75 x 75	x	4.0 SHS	8.49	0.283	33.3	16.8	1080	0.882	23.5	18.0	28.2	28.6	1.48	36.1											
75 x 75	x	3.5 SHS	7.53	0.285	37.9	19.4	959	0.797	21.3	16.1	25.3	28.8	1.32	32.5											
75 x 75	x	3.0 SHS	6.60	0.290	43.9	23.0	841	0.716	19.1	14.2	22.5	29.2	1.15	28.7											
75 x 75	x	2.5 SHS	5.56	0.291	52.4	28.0	709	0.614	16.4	12.0	19.1	29.4	0.971	24.6											
65 x 65	x	3.0 SHS	5.66	0.250	44.1	19.7	721	0.454	14.0	10.4	16.6	25.1	0.733	21.0											
65 x 65	x	2.5 SHS	4.78	0.251	52.6	24.0	609	0.391	12.0	8.91	14.1	25.3	0.624	18.1											
65 x 65	x	2.0 SHS	3.88	0.253	65.3	30.5	494	0.323	9.94	7.29	11.6	25.6	0.509	14.9											
50 x 50	x	4.0 SHS	5.35	0.183	34.2	10.5	681	0.229	9.15	7.33	11.4	18.3	0.403	14.3											
50 x 50	x	3.0 SHS	4.25	0.190	44.7	14.7	541	0.195	7.79	5.92	9.39	19.0	0.321	11.8											
50 x 50	x	2.5 SHS	3.60	0.191	53.1	18.0	459	0.169	6.78	5.09	8.07	19.2	0.275	10.2											
50 x 50	x	2.0 SHS	2.93	0.193	65.8	23.0	374	0.141	5.66	4.20	6.66	19.5	0.226	8.51											
50 x 50	x	1.6 SHS	2.38	0.195	81.7	29.3	303	0.117	4.68	3.44	5.46	19.6	0.185	7.03											
40 x 40	x	4.0 SHS	4.09	0.143	34.9	8.00	521	0.105	5.26	4.36	6.74	14.2	0.192	8.33											
40 x 40	x	2.5 SHS	2.82	0.151	53.7	14.0	359	0.0822	4.11	3.13	4.97	15.1	0.136	6.21											
40 x 40	x	2.0 SHS	2.31	0.153	66.4	18.0	294	0.0694	3.47	2.61	4.13	15.4	0.113	5.23											
40 x 40	x	1.6 SHS	1.88	0.155	82.3	23.0	239	0.0579	2.90	2.15	3.41	15.6	0.0927	4.36											

FIGURE D4 (in part) SQUARE HOLLOW SECTIONS

1	2	3	4	5	6	7	8	9	10	11	12	13								
													Designation	Mass per unit length	External surface area	Ratio	Gross area of cross-section	Second moment of area	Elastic section modulus	Elastic section modulus
Depth	Width	Thickness	$b$	$x$	$x$	$t$	$m$	$A_{EL}$	Per unit length	Per unit mass	$A_{EM}$	$\frac{b-2t}{t}$	$A_g$	$I_{x}, I_y$	$Z_x, Z_y$	$Z_n$	$S_x, S_y$	$r_x, r_y$	$J$	$C$
mm	mm	mm	mm	mm	mm	mm	kg/m	m <sup>2</sup> /m	m <sup>2</sup> /t	m <sup>2</sup> /t	m <sup>2</sup> /t		mm <sup>2</sup>	10 <sup>6</sup> mm <sup>4</sup>	10 <sup>3</sup> mm <sup>3</sup>	10 <sup>3</sup> mm <sup>3</sup>	10 <sup>3</sup> mm <sup>3</sup>	mm	10 <sup>6</sup> mm <sup>4</sup>	10 <sup>3</sup> mm <sup>3</sup>
35	35	3.0	SHS	2.83	0.130	45.8	9.67	361	0.0595	3.40	2.67	4.23	12.8	0.102	5.18					
35	35	2.5	SHS	2.42	0.131	54.2	12.0	309	0.0529	3.02	2.33	3.69	13.1	0.0889	4.58					
35	35	2.0	SHS	1.99	0.133	66.8	15.5	254	0.0451	2.58	1.95	3.09	13.3	0.0741	3.89					
35	35	1.6	SHS	1.63	0.135	82.7	19.9	207	0.0379	2.16	1.62	2.57	13.5	0.0611	3.26					
30	30	2.0	SHS	1.68	0.113	67.4	13.0	214	0.0272	1.81	1.39	2.21	11.3	0.0454	2.75					
30	30	1.6	SHS	1.38	0.115	83.3	16.8	175	0.0231	1.54	1.16	1.84	11.5	0.0377	2.32					
25	25	3.0	SHS	1.89	0.0897	47.4	6.33	241	0.0184	1.47	1.21	1.91	8.74	0.0333	2.27					
25	25	2.5	SHS	1.64	0.0914	55.7	8.00	209	0.0169	1.35	1.08	1.71	8.99	0.0297	2.07					
25	25	2.0	SHS	1.36	0.0931	68.3	10.5	174	0.0148	1.19	0.926	1.47	9.24	0.0253	1.80					
25	25	1.6	SHS	1.12	0.0945	84.1	13.6	143	0.0128	1.02	0.780	1.24	9.44	0.0212	1.54					
20	20	1.6	SHS	0.873	0.0745	85.4	10.5	111	0.00608	0.608	0.474	0.751	7.39	0.0103	0.924					

NOTE: The calculation of sectional properties is based on the following corner geometry.

Size range	Inside corner radius mm	Outside corner radius mm
Thickness 3.0 mm and less	1.0t	2.0t
Thickness greater than 3.0 mm	1.5t	2.5t

FIGURE D4 (in part) SQUARE HOLLOW SECTION

## APPENDIX E

## FORMULAE FOR THE CALCULATION OF SECTIONAL PROPERTIES

(Normative)

**E1 GENERAL**

The Tables in Figures D1, D2, D3 and D4 of this Standard give nominal sectional properties for a limited range of sizes of cold-formed structural steel hollow sections. The nominal sectional properties of hollow sections supplied to the requirements of this Standard shall be calculated using the formulae given below.

NOTE: The designation of the section's major axis ( $x$ ) and its minor axis ( $y$ ) align with the axis designation used for structural design in AS 4100, AS 5100.6 and NZS 3404.

**E2 CIRCULAR HOLLOW SECTIONS**

The sectional properties for circular hollow sections (CHS) in Figures D1 and D2 are calculated using the formulae given below.

Nominal outside diameter  $d_o$  (mm)

Nominal thickness  $t$  (mm)

Inside diameter  $d_i = (d_o - 2t)$  (mm)

These parameters, which characterize the shape of CHS, may vary within the tolerances allowed by this Standard and the nominal sectional properties still remain valid.

Gross area of the cross-section  $A_g = \frac{\pi(d_o^2 - d_i^2)}{4}$  (mm<sup>2</sup>)

External surface area per unit length  $A_{EL} = \frac{\pi d_o}{10^3}$  (m<sup>2</sup>/m)

External surface area per unit mass  $A_{EM} = \frac{A_{EL} \times 10^9}{7850 A_g}$  (m<sup>2</sup>/t)

Mass per unit length  $m = 0.00785 A_g$  (kg/m)

Second moment of area  $I = \frac{\pi(d_o^4 - d_i^4)}{64}$  (mm<sup>4</sup>)

Radius of gyration  $r = \sqrt{\frac{I}{A}}$  (mm)

Elastic section modulus  $Z = \frac{2I}{d_o}$  (mm<sup>3</sup>)

Plastic section modulus  $S = \frac{d_o^3 - d_i^3}{6}$  (mm<sup>3</sup>)

Torsion constant  
(polar moment of inertia)  $J = 2I$  (mm<sup>4</sup>)

Torsion modulus  $C = 2Z$  (mm<sup>3</sup>)

### E3 RECTANGULAR OR SQUARE HOLLOW SECTIONS

The sectional properties for rectangular hollow sections (RHS) in Figure D3 and for square hollow sections (SHS) in Figure D4 are calculated using the formulae given below.

Nominal dimension of the longer side of a RHS  $d$  (mm)

Nominal side dimension of a SHS or shorter side of a RHS  $b$  (mm)

Nominal thickness  $t$  (mm)

External corner radius for calculations  $r_o$  (mm)

Internal corner radius for calculations  $r_i (=r_o - t)$  (mm)

Unless subject to agreement between the finished product manufacturer, supplier and purchaser,  $r_o$  shall be taken as noted in Figure D3 for RHS and Figure D4 for SHS.

Gross area of the cross-section  $A_g = 2t(d + b - 2t) - (4 - \pi)(r_o^2 - r_i^2)$  (mm<sup>2</sup>)

External surface area per unit length  $A_{EL} = \frac{2}{10^3}(d + b - 4r_o + \pi r_o)$  (m<sup>2</sup>/m)

External surface area per unit mass  $A_{EM} = \frac{A_{EL} \times 10^9}{7850A_g}$  (m<sup>2</sup>/t)

Mass per unit length  $m = 0.00785A_g$  (kg/m)

Second moment of area

Major axis  $I_x = \left[ \frac{bd^3}{12} - \frac{(b-2t)(d-2t)^3}{12} - 4(I_{cro} + A_{cro}h_{cro}^2) + 4(I_{cri} + A_{cri}h_{cri}^2) \right]$  (mm<sup>4</sup>)

Minor axis  $I_y = \left[ \frac{db^3}{12} - \frac{(d-2t)(b-2t)^3}{12} - 4(I_{cro} + A_{cro}h_{cro}^2) + 4(I_{cri} + A_{cri}h_{cri}^2) \right]$  (mm<sup>4</sup>)

Radius of gyration

Major axis  $r_x = \sqrt{\frac{I_x}{A}}$  (mm)

Minor axis  $r_y = \sqrt{\frac{I_y}{A}}$  (mm)

Elastic section modulus

Major axis  $Z_x = \frac{2I_x}{d}$  (mm<sup>3</sup>)

Minor axis  $Z_y = \frac{2I_y}{b}$  (mm<sup>3</sup>)

Diagonal axis ( $n$ ) for SHS only  $Z_n = \frac{2I_x}{y_n}$  (mm<sup>3</sup>)



Plastic section modulus

$$\text{Major axis} \quad S_x = \left[ \frac{bd^2}{4} - \frac{(b-2t)(d-2t)^2}{4} - 4(A_{\text{cro}}h_{\text{cro}}) + 4(A_{\text{cri}}h_{\text{cri}}) \right] \quad (\text{mm}^3)$$

$$\text{Minor axis} \quad S_y = \left[ \frac{db^2}{4} - \frac{(d-2t)(b-2t)^2}{4} - 4(A_{\text{cro}}h_{\text{cro}}) + 4(A_{\text{cri}}h_{\text{cri}}) \right] \quad (\text{mm}^3)$$

$$\text{Torsion constant} \quad J = \left( t^3 \frac{h}{3} + 2KA_h \right) \quad (\text{mm}^4)$$

$$\text{Torsion modulus} \quad C = \left( \frac{J}{t + K/t} \right) \quad (\text{mm}^3)$$

$$\text{where} \quad A_{\text{cro}} = \left( 1 - \frac{\pi}{4} \right) r_o^2 \quad (\text{mm}^2)$$

$$A_{\text{cri}} = \left( 1 - \frac{\pi}{4} \right) r_i^2 \quad (\text{mm}^2)$$

$$\text{Major axis} \quad h_{\text{cro}} = \frac{d}{2} - \left( \frac{10-3\pi}{12-3\pi} \right) r_o \quad (\text{mm})$$

(For minor axis substitute  $b$  for  $d$ )

$$\text{Major axis} \quad h_{\text{cri}} = \frac{d-2t}{2} - \left( \frac{10-3\pi}{12-3\pi} \right) r_i \quad (\text{mm})$$

(For minor axis substitute  $b$  for  $d$ )

$$I_{\text{cro}} = \left( \frac{1}{3} - \frac{\pi}{16} - \frac{1}{3(12-3\pi)} \right) r_o^4 \quad (\text{mm}^4)$$

$$I_{\text{cri}} = \left( \frac{1}{3} - \frac{\pi}{16} - \frac{1}{3(12-3\pi)} \right) r_i^4 \quad (\text{mm}^4)$$

$$h = 2[(b-t) + (d-t)] - 2R_c(4-\pi) \quad (\text{mm})$$

$$A_h = [(b-t)(d-t)] - R_c^2(4-\pi) \quad (\text{mm}^2)$$

$$K = \frac{2A_h t}{h} \quad (\text{mm}^2)$$

$$R_c = \frac{r_o + r_i}{2} \quad (\text{mm})$$

$$y_n = \left[ \left( \frac{d}{2} - r_o \right)^2 + \left( \frac{b}{2} - r_o \right)^2 \right]^{0.5} + r_o \quad (\text{mm})$$

## BIBLIOGRAPHY

## AS

- 1199 Sampling procedures for inspection by attributes
- 1199.0 Part 0: Introduction to the ISO 2869 attribute sampling system
- 1199.1 Part 1: Sampling schemes indexed by acceptance quality limit (AQL) for lot-by-lot inspection
  
- 2490 Sampling procedures and charts for inspection by variables for percent non-conforming

## AS/NZS

- 2312 Guide to the protection of structural steel against atmospheric corrosion by the use of protective coatings
- 2312.2 Part 2: Hot dip galvanizing

## AS/NZS ISO

- 9001 Quality management systems—Requirements

### **Standards Australia**

Standards Australia is an independent company, limited by guarantee, which prepares and publishes most of the voluntary technical and commercial standards used in Australia. These standards are developed through an open process of consultation and consensus, in which all interested parties are invited to participate. Through a Memorandum of Understanding with the Commonwealth government, Standards Australia is recognized as Australia's peak national standards body.

### **Standards New Zealand**

The first national Standards organization was created in New Zealand in 1932. The New Zealand Standards Executive is established under the Standards and Accreditation Act 2015 and is the national body responsible for the production of Standards.

### **Australian/New Zealand Standards**

Under a Memorandum of Understanding between Standards Australia and Standards New Zealand, Australian/New Zealand Standards are prepared by committees of experts from industry, governments, consumers and other sectors. The requirements or recommendations contained in published Standards are a consensus of the views of representative interests and also take account of comments received from other sources. They reflect the latest scientific and industry experience. Australian/New Zealand Standards are kept under continuous review after publication and are updated regularly to take account of changing technology.

### **International Involvement**

Standards Australia and Standards New Zealand are responsible for ensuring that the Australian and New Zealand viewpoints are considered in the formulation of international Standards and that the latest international experience is incorporated in national and Joint Standards. This role is vital in assisting local industry to compete in international markets. Both organizations are the national members of ISO (the International Organization for Standardization) and IEC (the International Electrotechnical Commission).

### **Visit our web sites**

[www.standards.org.au](http://www.standards.org.au)

[www.standards.govt.nz](http://www.standards.govt.nz)



GPO Box 476 Sydney NSW 2001  
**Phone** (02) 9237 6000  
**Fax** (02) 9237 6010  
**Email** [mail@standards.org.au](mailto:mail@standards.org.au)  
**Internet** [www.standards.org.au](http://www.standards.org.au)  
**SAI Global Customer Service**  
**Phone** 13 12 42  
**Fax** 1300 65 49 49  
**Email** [sales@saiglobal.com](mailto:sales@saiglobal.com)



15 Stout Street Wellington 6011  
(PO Box 10729 Wellington 6011)  
**Freephone** 0800 782 632  
**Phone** (04) 498 5990  
**Fax** (04) 498 5994  
**Email** [enquiries@standards.govt.nz](mailto:enquiries@standards.govt.nz)  
**Website** [www.standards.govt.nz](http://www.standards.govt.nz)

This page has been left intentionally blank.