

Cold formed welded structural hollow sections of non-alloy and fine grain steels —

Part 1: Technical delivery conditions

The European Standard EN 10219-1:2006 has the status of a
British Standard

ICS 77.140.75

National foreword

This British Standard is the official English language version of EN 10219-1:2006. It supersedes BS EN 10219-1:1997 which is withdrawn.

The UK participation in its preparation was entrusted to Technical Committee ISE/12, Structural steels, which has the responsibility to:

- aid enquirers to understand the text;
- present to the responsible international/European committee any enquiries on the interpretation, or proposals for change, and keep UK interests informed;
- monitor related international and European developments and promulgate them in the UK.

A list of organizations represented on this committee can be obtained on request to its secretary.

Cross-references

The British Standards which implement international or European publications referred to in this document may be found in the *BSI Catalogue* under the section entitled “International Standards Correspondence Index”, or by using the “Search” facility of the *BSI Electronic Catalogue* or of British Standards Online.

This publication does not purport to include all the necessary provisions of a contract. Users are responsible for its correct application.

Compliance with a British Standard does not of itself confer immunity from legal obligations.

Summary of pages

This document comprises a front cover, an inside front cover, the EN title page, pages 2 to 35 and a back cover.

The BSI copyright notice displayed in this document indicates when the document was last issued.

Amendments issued since publication

Amd. No.	Date	Comments

This British Standard was published under the authority of the Standards Policy and Strategy Committee on 31 May 2006

© BSI 2006

ISBN 0 580 48341 X

English Version

Cold formed welded structural hollow sections of non-alloy and fine grain steels - Part 1: Technical delivery conditions

Profils creux pour la construction soudés, formés à froid en aciers non alliés et à grains fins - Partie 1 : Conditions techniques de livraison

Kaltgefertigte geschweißte Hohlprofile für den Stahlbau aus unlegierten Baustählen und aus Feinkornbaustählen - Teil 1: Technische Lieferbedingungen

This European Standard was approved by CEN on 16 March 2006.

CEN members are bound to comply with the CEN/CENELEC Internal Regulations which stipulate the conditions for giving this European Standard the status of a national standard without any alteration. Up-to-date lists and bibliographical references concerning such national standards may be obtained on application to the Central Secretariat or to any CEN member.

This European Standard exists in three official versions (English, French, German). A version in any other language made by translation under the responsibility of a CEN member into its own language and notified to the Central Secretariat has the same status as the official versions.

CEN members are the national standards bodies of Austria, Belgium, Cyprus, Czech Republic, Denmark, Estonia, Finland, France, Germany, Greece, Hungary, Iceland, Ireland, Italy, Latvia, Lithuania, Luxembourg, Malta, Netherlands, Norway, Poland, Portugal, Romania, Slovakia, Slovenia, Spain, Sweden, Switzerland and United Kingdom.



EUROPEAN COMMITTEE FOR STANDARDIZATION
COMITÉ EUROPÉEN DE NORMALISATION
EUROPÄISCHES KOMITEE FÜR NORMUNG

Management Centre: rue de Stassart, 36 B-1050 Brussels

Contents	Page
Foreword	3
1 Scope	4
2 Normative references	4
3 Terms, definitions and symbols	5
3.1 Terms and definitions	5
3.2 Symbols	5
4 Classification and designation	6
4.1 Classification	6
4.2 Designation	6
5 Information to be obtained by the manufacturer	7
5.1 Mandatory information	7
5.2 Options	7
5.3 Example of an order	7
6 Requirements	7
6.1 General	7
6.2 Steel manufacturing process	8
6.3 Condition of feedstock material	8
6.4 Structural hollow section manufacturing process	8
6.5 Delivery condition	8
6.6 Chemical composition	8
6.7 Mechanical properties	9
6.8 Technological properties	10
6.9 Surface condition	10
6.10 Non-destructive testing of welds	11
6.11 Tolerances and mass	11
7 Inspection	11
7.1 Types of inspection	11
7.2 Types of inspection document	11
7.3 Summary of inspection	12
8 Sampling	14
8.1 Frequency of tests	14
8.2 Preparation of samples and test pieces	14
9 Test methods	15
9.1 Chemical analysis	15
9.2 Mechanical tests	16
9.3 Visual inspection and dimensional check	16
9.4 Non-destructive testing	16
9.5 Retests, sorting and reprocessing	17
10 Marking	17
11 Evaluation of conformity	17
Annex A (normative) Structural hollow sections of non-alloy quality steels — Chemical composition and mechanical properties	18
Annex B (normative) Structural hollow sections of fine grain steels — Chemical composition and mechanical properties	20
Annex C (normative) Location of samples and test pieces	24
Annex D (normative) Evaluation of conformity	25
Annex ZA (informative) Clauses of this European Standard addressing the provisions of the EU Construction Products Directive	30
Bibliography	35

Foreword

This European Standard (EN 10219-1:2006) has been prepared by Technical Committee ECISS/TC 10 "Structural steels - Grades and qualities", the secretariat of which is held by NEN.

This European Standard shall be given the status of a national standard, either by publication of an identical text or by endorsement, at the latest by October 2006, and conflicting national standards shall be withdrawn at the latest by October 2006.

This European Standard supersedes EN 10219-1:1997.

This European Standard has been prepared under a mandate given to CEN by the European Commission and the European Free Trade Association, and supports essential requirements of EU Directive(s).

For relationship with EU Directive(s), see informative Annex ZA, which is an integral part of this European Standard.

This standard consists of the following parts under the general title 'Cold formed welded structural hollow sections of non-alloy and fine grain steels':

- Part 1: Technical delivery conditions
- Part 2: Tolerances, dimensions and sectional properties

It forms part of a series of standards on hollow sections together with EN 10210-1 and 2, which are also under revision.

According to the CEN/CENELEC Internal Regulations, the national standards organizations of the following countries are bound to implement this European Standard: Austria, Belgium, Cyprus, Czech Republic, Denmark, Estonia, Finland, France, Germany, Greece, Hungary, Iceland, Ireland, Italy, Latvia, Lithuania, Luxembourg, Malta, Netherlands, Norway, Poland, Portugal, Romania, Slovakia, Slovenia, Spain, Sweden, Switzerland and United Kingdom.

1 Scope

This part of this European Standard specifies the technical delivery conditions for cold formed welded structural hollow sections of circular, square or rectangular forms and applies to structural hollow sections formed cold without subsequent heat treatment.

Requirements for tolerances, dimensions and sectional properties are contained in EN 10219-2.

NOTE A range of steel grades is specified in this European Standard and the user should select the grade appropriate to the intended use and service conditions. The grades and mechanical properties of the finished hollow sections are compatible with those in EN 10025-2 and EN 10025-3.

2 Normative references

The following referenced documents are indispensable for the application of this European Standard. For dated references, only the edition cited applies. For undated references, the latest edition of the referenced document (including any amendments) applies.

EN 287-1, *Qualification test of welders - Fusion welding - Part 1: Steels*

EN 10002-1, *Metallic materials — Tensile testing — Part 1: Method of test at ambient temperature*

EN 10020:2000, *Definition and classification of grades of steel*

EN 10021:1993, *General technical delivery requirements for steel and iron products*

EN 10027-1, *Designation systems for steels — Part 1: Steel names*

EN 10027-2, *Designation systems for steels - Part 2: Numerical system*

EN 10045-1, *Metallic materials — Charpy impact test — Part 1: Test method*

EN 10052:1993, *Vocabulary of heat treatment terms for ferrous products*

EN 10168, *Steel products - Inspection documents - List of information and description*

EN 10204, *Metallic products — Types of inspection documents*

EN 10219-2:2006, *Cold formed welded structural hollow sections of non-alloy and fine grain steels — Part 2: Tolerances, dimensions and sectional properties*

EN 10246-3, *Non-destructive testing of steel tubes — Part 3: Automatic eddy current testing of seamless and welded (except submerged arc welded) steel tubes for the detection of imperfections*

EN 10246-5, *Non-destructive testing of steel tubes — Part 5: Automatic full peripheral magnetic transducer/flux leakage testing of seamless and welded (except submerged arc welded) ferromagnetic steel tubes for the detection of longitudinal imperfections*

EN 10246-8, *Non-destructive testing of steel tubes — Part 8: Automatic ultrasonic testing of the weld seam of electric welded steel tubes for the detection of longitudinal imperfections*

EN 10246-9, *Non-destructive testing of steel tubes — Part 9: Automatic ultrasonic testing of the weld seam of submerged arc-welded steel tubes for the detection of longitudinal and/or transverse imperfections*

EN 10246-10, *Non-destructive testing of steel tubes — Part 10: Radiographic testing of the weld seam of automatic fusion arc welded steel tubes for the detection of imperfections*

EN 10256, *Non-destructive testing of steel tubes - Qualification and competence of level 1 and 2 non-destructive testing personnel*

CR 10261, *ECISS Information Circular 11 – Iron and steel – Review of available methods of chemical analysis*

EN 10266:2003, *Steel tubes, fittings and steel structural hollow sections — Symbols and definitions of terms for use in product standards*

EN ISO 377, *Steel and steel products - Location and preparation of samples and test pieces for mechanical testing (ISO 377:1997)*

EN ISO 643, *Steels — Micrographic determination of the apparent grain size (ISO 643:2003)*

EN ISO 2566-1, *Steel — Conversion of elongation values — Part 1: Carbon and low alloy steels (ISO 2566-1:1984)*

EN ISO 9001:2000, *Quality management systems — Requirements (ISO 9001:2000)*

EN ISO 14284, *Steel and iron - Sampling and preparation of samples for the determination of chemical composition (ISO 14284:1996)*

EN ISO 15607, *Specification and qualification of welding procedures for metallic materials - General rules (ISO 15607:2003)*

EN ISO 15609-1, *Specification and qualification of welding procedures for metallic materials - Welding procedure specification - Part 1: Arc welding (ISO 15609-1:2004)*

EN ISO 15614-1, *Specification and qualification of welding procedures for metallic materials - Welding procedure test — Part 1: Arc and gas welding of steels and arc welding of nickel and nickel alloys (ISO 15614-1:2004)*

3 Terms, definitions and symbols

3.1 Terms and definitions

For the purpose of this European Standard, the following terms and definitions apply in addition to or where different from those in EN 10020:2000, EN 10021:1993, EN 10052:1993 and EN 10266:2003.

3.1.1 cold forming

process where the main forming is done at ambient temperature

3.1.2 normalizing rolling

rolling process in which the final deformation is carried out in a certain temperature range leading to a material condition equivalent to that obtained after normalizing so that the specified values of the mechanical properties are retained even after subsequent normalizing

3.1.3 thermomechanical rolling

rolling process in which the final deformation is carried out in a certain temperature range leading to a material condition with certain properties which cannot be achieved or repeated by heat treatment alone

NOTE 1 Subsequent heating above 580 °C may lower the strength values.

NOTE 2 Thermomechanical rolling, leading to the delivery condition M, can include processes with an accelerated cooling rate, with or without tempering including self-tempering, but excluding direct quenching and quenching and tempering.

3.2 Symbols

For the purposes of this European Standard, the symbols defined in EN 10266:2003 apply.

4 Classification and designation

4.1 Classification

4.1.1 Within the strength grades of the non-alloy steels given in Annex A, four qualities JR, J0, J2 and K2 are specified. These differ in respect of specified impact requirements, limits on values of various elements, with particular reference to sulfur and phosphorus, and the inspection and testing requirements.

In accordance with the classification system in EN 10020, all steel grades in Annex A are non-alloy quality steels.

4.1.2 Within the strength grades of the fine grain steels given in Annex B, four qualities N, NL, M and ML are specified. These differ in respect of the carbon, sulfur and phosphorus content and low temperature impact properties.

In accordance with the classification system in EN 10020, steel grades S275NH, S275NLH, S355NH and S355NLH are non-alloy quality steels, S460NH, S460NLH, S275MH to S460MH and S275MLH to S460MLH are alloy special steels.

4.2 Designation

4.2.1 For the products covered by this European Standard the steel names are allocated in accordance with EN 10027-1; the steel numbers are allocated in accordance with EN 10027-2.

4.2.2 For non-alloy steel hollow sections the steel designation consists of:

- the number of this European Standard (EN 10219-1);
- the capital letter S for structural steel;
- the indication of the minimum specified yield strength for thicknesses ≤ 16 mm expressed in MPa¹;
- the capital letters JR for the qualities with specified impact properties at room temperature, the characters J0 for the qualities with specified impact properties at 0 °C and the characters J2 or K2 for the qualities with specified impact properties at -20 °C;
- the capital letter H to indicate hollow sections.

EXAMPLE Structural steel (S) with a specified minimum yield strength for thickness not greater than 16 mm of 275 MPa, with a minimum impact energy value of 27 J at 0 °C (J0), hollow section (H):

EN 10219-S275J0H

4.2.3 For fine grain steel structural hollow sections the steel designation consists of:

- the number of this European Standard (EN 10219-1);
- the capital letter S for structural steel;
- the indication of the minimum specified yield strength for thicknesses ≤ 16 mm expressed in MPa;
- the capital letter N to indicate normalized or normalized rolled feedstock material or the capital letter M to indicate thermomechanically rolled feedstock material (see 6.3);
- the capital letter L for the qualities with specified impact properties at -50 °C;
- the capital letter H to indicate hollow sections.

1) 1 MPa = 1 N/mm²

EXAMPLE Structural steel (S) with a specified minimum yield strength for thickness not greater than 16 mm of 355 MPa, normalized fine grain steel feedstock (N), with a minimum impact energy value of 27 J at -50 °C (L), hollow section (H):

EN 10219-S355NLH

5 Information to be obtained by the manufacturer

5.1 Mandatory information

The following information shall be obtained by the manufacturer at the time of enquiry and order:

- a) the quantity (mass or total length);
- b) the type of length, length range or length (see EN 10219-2);
- c) details of the product form:

CFCHS = cold formed circular hollow section;

CFRHS = cold formed square or rectangular hollow section;

- d) the steel designation (see 4.2);
- e) the dimensions (see EN 10219-2).

5.2 Options

A number of options are specified in this part of this European Standard. These are listed below with appropriate clause references. In the event that the purchaser does not indicate a wish to implement any of these options at the time of enquiry and order, the hollow sections shall be supplied in accordance with the basic specification.

- 1.1 Product analysis (see 6.6.1).
- 1.2 Cr, Cu, Mo, Ni, Ti and V cast analysis contents to be reported (see 6.6.2).
- 1.3 Verification of impact properties for qualities J0 and JR (see 6.7.4).
- 1.4 Suitability for hot dip galvanizing (see 6.8.2).
- 1.5 Weld repairs to the body of non-alloy structural steel hollow sections not permitted (see 6.9.4).
- 1.6 Specific inspection and testing for non-alloy quality grades JR and J0 (see 7.1.1).
- 1.7 Inspection document other than the standard document (see 7.2.2).

5.3 Example of an order

10 t of 8 m to 10 m random length cold finished square hollow sections in accordance with EN 10219, made from non-alloy quality structural steel S355NH, with specified outside dimensions 100 mm × 100 mm and wall thickness of 8 mm, supplied with product analysis (Option 1.1) and suitable for hot dip galvanising (Option 1.4).

10 t, 8-10m Random lengths – CFRHS – EN 10219 – S355NH – 100 x 100 x 8 – Options 1.1, 1.4

6 Requirements

6.1 General

Structural hollow sections of non-alloy steels shall conform to the requirements of Annex A. Structural hollow sections of fine grain steels shall conform to the requirements of Annex B.

EN 10219-1:2006 (E)

In addition, the general technical delivery requirements specified in EN 10021 shall apply.

6.2 Steel manufacturing process

6.2.1 The steel manufacturing process shall be at the discretion of the steel producer.

6.2.2 For the non-alloy steels given in Annex A, the method of deoxidation shall be as specified in Table A.1.

6.2.3 For the fine grain steels given in Annex B the method of deoxidation shall be as specified in Table B.1 or Table B.2.

6.2.4 The fine grain steels given in Annex B shall have a ferritic grain size equal to or finer than 6 when measured in accordance with EN ISO 643 (see 6.7.3).

6.3 Condition of feedstock material

According to the designation given in the order the following delivery conditions apply for the feedstock material used for the manufacture of cold formed hollow sections:

- as rolled or normalized/normalized rolled (N) for steels of qualities JR, J0, J2 and K2 according to Annex A;
- normalized/normalized rolled (N) for steels of qualities N and NL according to Annex B;
- thermomechanically rolled (M) for steels of quality M and ML according to Annex B.

6.4 Structural hollow section manufacturing process

6.4.1 Structural hollow sections shall be manufactured by electric welding or submerged arc welding without subsequent heat treatment (see 6.5). Hollow sections manufactured by a continuous process shall not include the welds used to join the lengths of strip prior to forming the hollow section, except that for helically welded submerged arc-welded (SAW) hollow sections, such welds shall be permitted when tested in accordance with 9.4.3.

6.4.2 Electric welded hollow sections are normally supplied without trimming the internal weld bead.

6.4.3 All NDT activities shall be carried out by qualified and competent level 1, 2 and/or 3 personnel authorised to operate by the employer.

The qualification shall be in accordance with EN 10256 or, at least, an equivalent to it.

It is recommended that the level 3 personnel be certified in accordance with EN 473 or, at least, an equivalent to it.

The operating authorisation issued by the employer shall be in accordance with a written procedure.

NDT operations shall be authorised by a level 3 NDT individual approved by the employer.

NOTE The definition of levels 1, 2 and 3 can be found in the appropriate standards, e.g. EN 473 and EN 10256.

6.5 Delivery condition

The hollow sections shall be delivered cold formed without subsequent heat treatment except that the weld seam may be in the as welded or heat treated condition.

NOTE For SAW hollow sections above 508 mm outside diameter it may be necessary to perform a warm shaping operation, which does not affect the mechanical properties, in order to meet the out-of-roundness tolerance requirements.

6.6 Chemical composition

6.6.1 The cast analysis reported by the steel producer shall apply and shall conform to the requirements given in Table A.1, Table B.1 or Table B.2.

The maximum carbon equivalent value (CEV) for all grades, based on the cast analyses, given in Table A.2 or Table B.3, shall apply. When determining the CEV the following formula shall be used.

$$CEV = C + \frac{Mn}{6} + \frac{Cr + Mo + V}{5} + \frac{Ni + Cu}{15}$$

Option 1.1 for products supplied with specific inspection and testing, a product analysis shall be reported.

Deviations of the product analysis from the specified limits of the cast analysis shall be in accordance with Table 1.

Table 1 — Permissible deviations of the product analysis from the specified limits of the cast analysis given in Tables A.1, B.1 and B.2

Element	Permissible maximum content in the cast analysis		Permissible deviation of the product analysis from specified limits for the cast analysis
	% by mass		
C ^a	≤ 0,20		+ 0,02
	> 0,20		+ 0,03
Si	≤ 0,60		+ 0,05
Mn	non-alloy	≤ 1,60	+ 0,10
	fine grain	≤ 1,70	- 0,05 + 0,10
P	non-alloy	≤ 0,040	+ 0,010
	fine grain	≤ 0,035	+ 0,005
S	non-alloy	≤ 0,040	+ 0,010
	fine grain	≤ 0,030	+ 0,005
Nb	≤ 0,050		+ 0,010
V	≤ 0,20		+ 0,02
Ti	≤ 0,05		+ 0,01
Cr	≤ 0,30		+ 0,05
Ni	≤ 0,80		+ 0,05
Mo	≤ 0,20		+ 0,03
Cu	≤ 0,35		+ 0,04
	0,35 < Cu ≤ 0,70		+ 0,07
N	≤ 0,025		+ 0,002
Al _{Total}	≥ 0,020		- 0,005
^a For S235JRH in thicknesses ≤ 16 mm, the permissible deviation = 0,4 % C, and for thicknesses >16 mm and ≤ 40 mm the permissible deviation = 0,05 % C.			

6.6.2 For non-alloy steel products supplied with specific inspection and testing the following option may be specified (see 7.1):

Option 1.2 the recording on the inspection certificate of the Cr, Cu, Mo, Ni, Ti and V content (cast analysis).

6.7 Mechanical properties

6.7.1 Under the inspection and testing conditions as specified in Clause 7 and in the delivery condition specified in 6.5, the mechanical properties shall conform to the relevant requirements of Tables A.3, B.4 or B.5.

NOTE Stress relief annealing at more than 580 °C or for over one hour may lead to deterioration of the mechanical properties.

6.7.2 For impact tests, standard V-notch test pieces in accordance with EN 10045-1 shall be used. If the nominal product thickness is not sufficient for the preparation of standard test pieces, the test shall be carried out using test pieces of width less than 10 mm, but not less than 5 mm. The minimum average values given in Tables A.3, B.4 and B.5 shall be reduced in direct proportion of the actual width of the test piece compared to that of the standard test piece.

Impact tests are not required for specified thicknesses < 6 mm.

EN 10219-1:2006 (E)

6.7.3 For fine grain steel hollow sections in thicknesses which do not permit impact test pieces of width ≥ 5 mm to be taken, the ferritic grain size (see 6.2.4) shall be verified by the method as described in EN ISO 643.

When aluminium is used as the grain refining element, the grain size requirement shall be deemed to be fulfilled if the cast analysis shows the aluminium content to be not less than 0,020 % total aluminium or alternatively 0,015 % soluble aluminium. In these cases, verification of the grain size is not required.

6.7.4 Subject to the limitations of 6.7.2

- a) the impact properties of structural hollow sections of steel qualities J2, K2, M, N, ML and NL shall be verified;
- b) the impact properties of structural hollow sections of steel qualities JR and J0 are not verified unless otherwise specified by the purchaser at the time of enquiry and order.

Option 1.3 for products in qualities JR and J0 supplied with specific inspection and testing (see Option 1.6), the verification of the impact properties is specified.

6.8 Technological properties

6.8.1 Weldability

The steels specified in this European Standard are weldable. General requirements for welding the products in accordance with this European Standard are given in EN 1011-1 and EN 1011-2.

NOTE 1 When welding these products, as product thickness, strength level and CEV increase, the occurrence of cold cracking in the welded zone forms the main risk. Cold cracking is caused by a combination of the following factors:

- high levels of diffusible hydrogen in the weld metal;
- a brittle structure in the heat affected zone;
- significant tensile stress concentrations in the welded joint.

NOTE 2 By using guidelines, specified for example in EN 1011-1, EN 1011-2 or any other relevant standard, the recommended welding conditions and the various welding ranges for the steel grades can be determined. These will vary depending on the product thickness, the applied welding energy, the design requirements, the electrode efficiency, the welding process and the weld metal properties.

6.8.2 Suitability for hot dip galvanizing

Option 1.4 the products shall be suitable for hot dip galvanizing.

6.9 Surface condition

6.9.1 The hollow sections shall have a smooth surface corresponding to the manufacturing method used; bumps, cavities or shallow longitudinal grooves resulting from the manufacturing process are permissible, provided the remaining thickness is within tolerance.

Surface defects may be removed by the manufacturer by grinding, provided that the thickness of the hollow section after the repair is not less than the minimum permissible thickness in accordance with EN 10219-2.

6.9.2 The ends of the hollow section shall be cut nominally square to the axis of the product.

6.9.3 For both non-alloy and fine grain hollow sections, repair of the weld shall be permitted.

6.9.4 For non-alloy hollow sections, repair of the body by welding shall be permitted unless otherwise specified. The conditions under which, and the extent to which, welding repair to the body may be carried out shall be agreed between the manufacturer and the purchaser.

Option 1.5 repair of the body by welding shall not be carried out.

For fine grain hollow sections, repair of the body by welding shall not be permitted unless otherwise agreed.

6.9.5 Welding repair shall be carried out by operators qualified in accordance with EN 287-1. Welding repair procedures shall be in accordance with EN ISO 15607, EN ISO 15609-1 and EN ISO 15614-1.

6.9.6 The repaired hollow section shall conform to all the requirements of this European Standard.

6.10 Non-destructive testing of welds

The seam weld of all hollow sections supplied with specific inspection and testing shall be subjected to a non-destructive test in accordance with 9.4.

6.11 Tolerances and mass

6.11.1 Tolerances

Tolerances shall be as specified in EN 10219-2.

6.11.2 Mass

Mass shall be determined using a density of 7,85 kg/dm³.

NOTE Dimensions, sectional properties and mass per unit length for a limited range of sizes of cold formed structural hollow sections are given in EN 10219-2. The purchaser should preferably select hollow section dimensions from this limited range of sizes.

7 Inspection

7.1 Types of inspection

7.1.1 Non-alloy steel hollow sections of qualities JR and J0 (see Annex A) shall be supplied with non-specific inspection in accordance with EN 10021 unless Option 1.6 is specified.

Option 1.6 qualities JR and J0 shall be supplied with specific inspection.

7.1.2 Non-alloy steel hollow sections of qualities J2 and K2 (see Annex A) and fine grain steel hollow sections of qualities M, N, ML and NL (see Annex B) shall be supplied with specific inspection in accordance with EN 10021.

7.2 Types of inspection document

7.2.1 For products supplied with non-specific inspection a test report (2.2) in accordance with EN 10204 shall be provided.

The test report shall contain the following codes and relevant information in accordance with EN 10168:

A — Commercial transactions and parties involved.

B — Description of products to which the test report applies.

C — Information on tests as follows:

C10-C13 — Tensile test;

C71-C92 — Cast analysis.

Z — Validation.

7.2.2 For products supplied with specific inspection an inspection certificate 3.1 in accordance with EN 10204 shall be provided unless Option 1.7 is specified.

EN 10219-1:2006 (E)

Option 1.7 an inspection certificate 3.2 in accordance with EN 10204 shall be supplied. Where this document is specified, the purchaser shall notify the manufacturer of the address of the organization or person nominated by him to carry out the inspection and validate the inspection document. It shall also be agreed which party shall issue the certificate.

The inspection certificate shall contain the following codes and related information in accordance with EN 10168:

- A — Commercial transactions and parties involved.
- B — Description of products to which the inspection certificate applies.
- C — Information on tests as follows:
 - C02-C03 — Direction of test pieces and test temperature;
 - C10-C13 — Tensile test — Test piece shape and test results;
 - C40-C43 — Impact test — Test piece type and test results, if applicable;
 - C71-C92 — Cast analysis and, if applicable, product analysis.
- Z — Validation.

7.3 Summary of inspection

The requirements for inspection are given in Table 2 for hollow sections of non-alloy steels and in Table 3 for hollow sections of fine grain steels.

Table 2 — Inspection programme for hollow sections of non-alloy steels

Inspection requirements				Inspection programme	
Type of test			Subclause reference(s)	Non-specific inspection	Specific inspection
Mandatory tests	1	Cast analysis	6.6 9.1	One result per delivery item	One per cast
	2	Tensile test	6.7 9.2	One result per delivery item	One per test unit ^{a b}
	3	Impact test for qualities J2 and K2 only	6.7 9.2	Not applicable	One set per test unit ^{a b}
	4	Surface condition and dimensions	6.9 6.11 9.3	See 9.3	See 9.3
	5	NDT of the weld	6.10 9.4	Not applicable	All products, full length
Optional tests	6	Product analysis (Option 1.1)	6.6 9.1	Not applicable	One per test unit ^a
	7	Cast analysis additional elements (Option 1.2)	6.6 9.1	Not applicable	See Option 1.2
	8	Impact test for qualities JR and JO (Option 1.3)	6.7 9.2	Not applicable	One set per test unit ^{a b}
^a For test units see 8.1.3. ^b Longitudinal or transverse samples at the discretion of the manufacturer.					

Table 3 — Inspection programme for hollow sections of fine grain steels

Inspection requirements				Inspection programme	
Type of test			Subclause reference(s)	Specific inspection	
Mandatory tests	1	Cast analysis	6.6 9.1	One per cast	
	2	Tensile test	6.7 9.2	One per test unit ^{a b}	
	3	Impact test	6.7 9.2	One set per test unit ^{a b}	
	4	Surface condition and dimensions	6.9 6.11 9.3	See 9.3	
	5	NDT of the weld	6.10 9.4	All products, full length	
Optional tests	6	Product analysis (Option 1.1)	6.6 9.1	One per test unit ^a	
^a For test units see 8.1.3. ^b Longitudinal or transverse samples at the discretion of the manufacturer.					

8 Sampling

8.1 Frequency of tests

8.1.1 For products supplied with non-specific inspection, see Table 2.

8.1.2 For products supplied with specific inspection, the verification of the mechanical properties and product analysis, if applicable, shall be carried out by test unit. A test unit is defined as a quantity of hollow sections from one or more cast(s) of the same grade and dimensions manufactured by the same process (i.e. electric welding or submerged arc welding), and, if applicable, in the same heat treatment condition, submitted for acceptance at the same time.

The following samples shall be taken from one sample product of each test unit:

- 1 sample for tensile testing;
- 1 sample sufficient for 2 sets of 3 impact test pieces;
- 1 sample for product analysis, when required, see 8.2.1.

8.1.3 The mass of a test unit shall not exceed the maximum tonnage of sections specified in Table 4.

Table 4 — Test units

Type of hollow section		Test unit
Circular	Square or rectangular	
Outside diameter <i>D</i> mm	External perimeter mm	Mass maximum t
≤ 114,3	≤ 400	40
> 114,3 ≤ 323,9	> 400 ≤ 800	50
> 323,9	> 800	75

8.2 Preparation of samples and test pieces

8.2.1 Selection and preparation of samples for chemical analysis

Samples for product analysis, when required, shall be taken from the sample product or alternatively from test pieces used for mechanical testing or from the full thickness of the hollow section at the same location as for the mechanical test samples. The preparation of samples shall be in accordance with EN ISO 14284.

8.2.2 Preparation of test pieces for mechanical tests

8.2.2.1 General

The requirements of EN ISO 377 shall apply in conjunction with the test piece location specified in 8.2.3.

8.2.2.2 Tensile test pieces

The requirements of EN 10002-1, as appropriate, shall apply.

Test pieces may be non-proportional, but in cases of dispute proportional test pieces having a gauge length $L_0 = 5,65\sqrt{S_0}$ shall be used (see 9.2.2). For thicknesses less than 3 mm, a gauge length of $L_0 = 80$ mm shall be used provided a test piece width of 20 mm can be achieved, otherwise a gauge length of 50 mm shall be used with a test piece width of 12,5 mm.

8.2.2.3 Impact test pieces

Impact V-notch test pieces shall be prepared and machined in accordance with EN 10045-1. In addition, the following requirements shall apply:

- a) for specified thicknesses > 12 mm, standard test pieces shall be machined in such a way that one side is not further away than 2 mm from a rolled surface;
- b) for specified thicknesses ≤ 12 mm, when test pieces with reduced sections are used, the width shall be ≥ 5 mm.

NOTE Test piece size is dependent on the actual thickness of the sample and, for circular hollow sections, allowance also needs to be made for the curvature of the section.

8.2.3 Location and orientation of samples for mechanical tests

8.2.3.1 Tensile test pieces

The test pieces for tensile testing shall conform to the following:

- a) the test piece may be the full section of the product;
- b) for circular sections, not tested in full section, the test pieces shall be taken either longitudinally or transversely, at the discretion of the manufacturer, at a point remote from the weld (see Annex C);
- c) for square or rectangular sections, not tested in full section, the test pieces shall be taken either longitudinally or transversely, at the discretion of the manufacturer, midway between the corners, from one of the sides not containing the weld (see Annex C).

8.2.3.2 Impact test pieces

Test pieces for impact testing shall conform to the following:

- a) for circular sections the test pieces shall be taken either longitudinally or transversely, at the discretion of the manufacturer, at a point remote from the weld (see Annex C);
- b) for square or rectangular sections the test pieces shall be taken either longitudinally or transversely, at the discretion of the manufacturer, midway between the corners, from one of the sides not containing the weld (see Annex C).

9 Test methods

9.1 Chemical analysis

The elements to be determined and reported shall be those given in Table A.1, and Option 1.2 if specified, or those in Table B.1 or Table B.2, as applicable.

The choice of a suitable physical or chemical analytical method for the analysis shall be at the discretion of the manufacturer.

In case of dispute, the method used shall be agreed taking into account CR 10261.

9.2 Mechanical tests

9.2.1 Test temperature

Tensile tests shall be carried out in the temperature range 10 °C to 35 °C. Impact tests shall be carried out at the temperatures specified in Table A.3 for non-alloy steels and Tables B.4 or B.5 for fine grain steels.

9.2.2 Tensile tests

The tensile test shall be carried out in accordance with EN 10002-1.

For the specified yield strengths in Tables A.3, B.4 and B.5, the upper yield strength (R_{eH}) shall be determined.

If a yield phenomenon is not present, the 0,2 % proof strength non-proportional extension ($R_{p0,2}$) or the 0,5 % proof strength total extension ($R_{t0,5}$) shall be determined. In cases of dispute, the 0,2 % proof strength ($R_{p0,2}$) shall apply.

If a non-proportional test piece is used, the percentage elongation value obtained after fracture (A) shall be converted to the value for a gauge length $L_0 = 5,65 \sqrt{S_0}$ using the conversion tables given in EN ISO 2566-1.

For thicknesses less than 3 mm the percentage elongation may be reported for a gauge length of 80 mm or 50 mm (see 8.2.2.2).

9.2.3 Impact tests

The impact test shall be carried out in accordance with EN 10045-1. In addition, the following requirements shall apply:

- a) The average value of a set of three test pieces shall be equal to or greater than the specified value. One individual value may be below the specified value, provided that it is not less than 70 % of that value;
- b) If the conditions under a) are not satisfied then an additional set of three test pieces may be taken, at the discretion of the manufacturer, from the same sample and tested. To consider the test unit as conforming after testing the second set, the following conditions shall all be satisfied simultaneously:
 - 1) The average value of the six tests shall be equal to or greater than the minimum specified value;
 - 2) Not more than two of the six individual values may be lower than the minimum specified value;
 - 3) Not more than one of the six individual values may be lower than 70 % of the minimum specified value.
- c) If these conditions are not satisfied, the sample product is rejected and retests shall be carried out on the remainder of the test unit (see 9.5).

9.3 Visual inspection and dimensional check

9.3.1 Visual inspection

The hollow sections shall be visually inspected for compliance with the requirements of 6.9.

9.3.2 Dimensional check

The dimensions of the hollow sections shall be checked for compliance with the requirements of EN 10219-2.

9.4 Non-destructive testing

9.4.1 General

When the welds of structural hollow sections are to be subjected to non-destructive testing, the method shall be in accordance with 9.4.2 or 9.4.3. At the manufacturer's discretion, the non-destructive testing may be carried out

either on the circular shape prior to final forming or on the circular, square or rectangular hollow sections after final forming.

9.4.2 Electric welded sections

The weld seam of electric welded hollow sections shall be tested in accordance with one of the following European Standards. The standard to be applied is at the discretion of the manufacturer.

- a) EN 10246-3 to acceptance level E4, with the exception that the rotating tube/pancake coil technique shall not be permitted;
- b) EN 10246-5 to acceptance level F5;
- c) EN 10246-8 to acceptance level U5.

9.4.3 Submerged arc welded sections

The weld seam of submerged arc welded hollow sections shall be tested either in accordance with EN 10246-9 to acceptance level U4 or by radiography in accordance with EN 10246-10 with an image quality class R2.

Butt welds, used to join lengths of strip/plate together in the spiral submerged arc weld process, shall be permitted, provided that the butt weld is tested to the same type of procedure and meets the same acceptance level as the main weld seam.

9.5 Retests, sorting and reprocessing

For retests, sorting and reprocessing, EN 10021 shall apply.

10 Marking

10.1 Except as provided for in 10.2 for hollow sections which are bundled, each hollow section shall be marked by suitable and durable methods such as painting, stamping, adhesive labels or attached tags with the following:

- the steel designation e.g. EN 10219-S275J0H;
- the manufacturer's name or trademark;
- in the case of specific inspection:
 - an identification number, e.g. order number, which permits the correlation of the product or delivery unit to the related document;
 - the mark of the external inspection representative (where applicable).

10.2 Where the products are supplied bundled, the marking required in 10.1 shall be on a label, which shall be securely attached to the bundle.

11 Evaluation of conformity

Where evaluation of conformity is required for regulatory purposes Annex D shall apply.

Annex A (normative)

Structural hollow sections of non-alloy quality steels — Chemical composition and mechanical properties

Table A.1 — Chemical composition — Cast analysis for product thickness ≤ 40 mm

Steel grade		Type of de-oxidation ^a	% by mass, maximum					
Steel name	Steel number		C	Si	Mn	P	S	N ^b
S235JRH	1.0039	FF	0,17	—	1,40	0,040	0,040	0,009
S275J0H	1.0149	FF	0,20	—	1,50	0,035	0,035	0,009
S275J2H	1.0138	FF	0,20	—	1,50	0,030	0,030	—
S355J0H	1.0547	FF	0,22	0,55	1,60	0,035	0,035	0,009
S355J2H	1.0576	FF	0,22	0,55	1,60	0,030	0,030	—
S355K2H	1.0512	FF	0,22	0,55	1,60	0,030	0,030	—

a The deoxidation method is designated as follows:
FF: Fully killed steel containing nitrogen binding elements in amounts sufficient to bind available nitrogen (e.g. min. 0,020 % total Al or 0,015 % soluble Al).

b The maximum value for nitrogen does not apply if the chemical composition shows a minimum total Al content of 0,020 % with a minimum Al/N ratio of 2:1, or if sufficient other N-binding elements are present. The N-binding elements shall be recorded in the Inspection Document.

Table A.2 — Maximum carbon equivalent value (CEV) based on cast analysis ^a

Steel grade		Maximum CEV for nominal thicknesses ≤ 40 mm
Steel name	Steel number	
S235JRH	1.0039	%
S275J0H	1.0149	0,35
S275J2H	1.0138	0,40
S355J0H	1.0547	0,40
S355J2H	1.0576	0,45
S355K2H	1.0512	0,45

^a See 6.6.2, Option 1.2.

Table A.3 — Mechanical properties of non-alloy steel hollow sections in thicknesses ≤ 40 mm

Steel grade		Minimum yield strength R_{eH} MPa		Tensile strength R_m MPa		Minimum elongation A^d %	Minimum impact energy KV^e J		
Steel name	Steel number								
		Specified thickness mm		Specified thickness mm		Specified thickness mm	at test temperature of		
		≤ 16	$> 16 \leq 40$	< 3	$\geq 3 \leq 40$	≤ 40	-20 °C	0 °C	20 °C
S235JRH ^a	1.0039	235	225	360-510	360-510	24 ^b	-	-	27
S275J0H ^a	1.0149	275	265	430-580	410-560	20 ^c	-	27	-
S275J2H	1.0138						27	-	-
S355J0H ^a	1.0547	355	345	510-680	470-630	20 ^c	-	27	-
S355J2H	1.0576						27	-	-
S355K2H	1.0512						40 ^f	-	-

^a The impact properties are verified only when Option 1.3 is specified.

^b For thicknesses > 3 mm and section sizes $D/T < 15$ (round) and $(B+H)/2T < 12,5$ (square and rectangular) the minimum elongation is reduced by 2. For thicknesses ≤ 3 mm the minimum value for elongation is 17 %.

^c For section sizes $D/T < 15$ (circular) and $(B+H)/2T < 12,5$ (square and rectangular) the minimum elongation is reduced by 2.

^d For thicknesses < 3 mm see 9.2.2.

^e For impact properties for reduced section test pieces see 6.7.2.

^f This value corresponds to 27J at -30 °C (see EN 1993-1-1).

Annex B (normative)

Structural hollow sections of fine grain steels — Chemical composition and mechanical properties

Table B.1 — Chemical composition — Cast analyses for product thicknesses ≤ 40 mm, feedstock condition N^a

Steel grade		Type of deoxidation ^b	Classification ^c	% by mass													
Steel name	Steel number			C max.	Si max.	Mn	P max.	S max.	Nb max.	V max.	Al total ^d min.	Ti max.	Cr max.	Ni max.	Mo max.	Cu ^e max.	N max.
S275NH	1.0493	GF	QS	0,20	0,40	0,50-1,40	0,035	0,030	0,050	0,05	0,020	0,03	0,30	0,30	0,10	0,35	0,015
S275NLH	1.0497						0,030	0,025									
S355NH	1.0539	GF	QS	0,20	0,50	0,90-1,65	0,035	0,030	0,050	0,12	0,020	0,03	0,30	0,50	0,10	0,35	0,015
S355NLH	1.0549			0,18			0,030	0,025									
S460NH	1.8953	GF	SS	0,20	0,60	1,00-1,70	0,035	0,030	0,050	0,20	0,020	0,03	0,30	0,80	0,10	0,70	0,025
S460NLH	1.8956						0,030	0,025									

a See 6.3.

b The deoxidation method is designated as follows:
GF = Fully killed steel containing nitrogen binding elements in amounts sufficient to bind the available nitrogen and having a fine grained structure.

c QS = quality steel; SS = special steel.

d If sufficient N-binding elements are present, the minimum total Al content does not apply.

e If the copper content is greater than 0,30 % then the nickel content shall be at least half of the copper content.

Table B.2 — Chemical composition - Cast analysis for product thicknesses ≤ 40 mm, feedstock condition M ^a

Steel grade		Type of deoxidation ^b	Classification ^c	% by mass											
Steel name	Steel number			C max.	Si max.	Mn max.	P max.	S max.	Nb max.	V max.	Al total ^d min.	Ti max.	Ni max.	Mo ^e max.	N max.
S275MH	1.8843	GF	SS	0,13	0,50	1,50	0,035	0,030	0,050	0,08	0,020	0,050	0,30	0,20	0,020
S275MLH	1.8844						0,030	0,025							
S355MH	1.8845	GF	SS	0,14	0,50	1,50	0,035	0,030	0,050	0,10	0,020	0,050	0,30	0,20	0,020
S355MLH	1.8846						0,030	0,025							
S420MH	1.8847	GF	SS	0,16	0,50	1,70	0,035	0,030	0,050	0,12	0,020	0,050	0,30	0,20	0,020
S420MLH	1.8848						0,030	0,025							
S460MH	1.8849	GF	SS	0,16	0,60	1,70	0,035	0,030	0,050	0,12	0,020	0,050	0,30	0,20	0,025
S460MLH	1.8850						0,030	0,025							

^a See 6.3.

^b The deoxidation method is designated as follows:
GF = Fully killed steel containing nitrogen binding elements in amounts sufficient to bind the available nitrogen and having a fine grained structure.

^c SS = special steel.

^d If sufficient N-binding elements are present, the minimum total Al content does not apply.

^e The total sum of Cr, Cu and Mo shall not be higher than 0,60 %.

Table B.3 — Maximum carbon equivalent value based on cast analysis

Steel grade		Maximum CEV for nominal thicknesses ≤ 40 mm %
Steel name	Steel number	
S275NH S275NLH	1.0493 1.0497	0,40
S275MH S275MLH	1.8843 1.8844	0,34
S355NH S355NLH	1.0539 1.0549	0,43
S355MH S355MLH	1.8845 1.8846	0,39
S420MH S420MLH	1.8847 1.8848	0,43
S460NH S460NLH	1.8953 1.8956	0,53
S460MH S460MLH	1.8849 1.8850	0,46

Table B.4 — Mechanical properties of hollow sections in thicknesses ≤ 40 mm — Feedstock material condition N

Steel grade		Minimum yield strength R_{eH} MPa	Tensile strength R_m MPa	Minimum elongation A_{ab} %	Minimum impact energy KV^c J	
Steel name	Steel number				at test temperature of	
		Specified thickness mm	Specified thickness mm	Specified thickness mm		
		≤ 16	$> 16 \leq 40$	≤ 40	-50 °C	-20 °C
S275NH	1.0493	275	265	370-510	24	-
S275NLH	1.0497					40 ^d
S355NH	1.0539	355	345	470-630	22	-
S355NLH	1.0549					40 ^d
S460NH	1.8953	460	440	540-720	17	-
S460NLH	1.8956					40 ^d

^a For section sizes $D/T < 15$ (circular) and $(B+H)/2T < 12,5$ (square and rectangular) the minimum elongation is reduced by 2.

^b For thicknesses < 3 mm see 9.2.2.

^c For impact properties for reduced section test pieces see 6.7.2.

^d This value corresponds to 27J at -30 °C (see EN 1993-1-1).

Table B.5 — Mechanical properties of hollow sections in thicknesses ≤ 40 mm — Feedstock material condition M

Steel grade		Minimum yield strength R_{eH}		Tensile strength R_m	Minimum elongation $A_{a,b}$	Minimum impact energy KV^c	
Steel name	Steel number	MPa		MPa	%	J	
		Specified thickness		Specified thickness	Specified thickness	at test temperature of	
		mm		mm	mm		
		≤ 16	$> 16 \leq 40$	≤ 40	≤ 40	-50 °C	-20 °C
S275MH	1.8843	275	265	360-510	24	-	40 ^d
S275MLH	1.8844					27	-
S355MH	1.8845	355	345	450-610	22	-	40 ^d
S355MLH	1.8846					27	-
S420MH	1.8847	420	400	500-660	19	-	40 ^d
S420MLH	1.8848					27	-
S460MH	1.8849	460	440	530-720	17	-	40 ^d
S460MLH	1.8850					27	-

^a For section sizes $D/T < 15$ (circular) and $(B+H)/2T < 12,5$ (square and rectangular) the minimum elongation is reduced by 2.
^b For thicknesses < 3 mm see 9.2.2.
^c For impact properties for reduced section test pieces see 6.7.2.
^d This value corresponds to 27J at -30 °C (see EN 1993-1-1).

Annex C (normative)

Location of samples and test pieces

Figures C.1 and C.2 give information on the location of samples and test pieces for hollow sections (see 8.2.2).

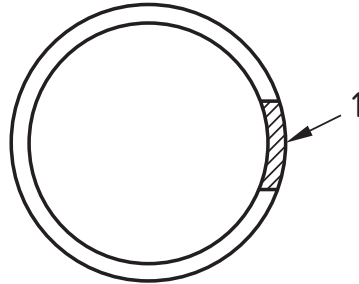

Key

- 1 At any point on circumference but remote from the weld

Figure C.1 — Circular sections

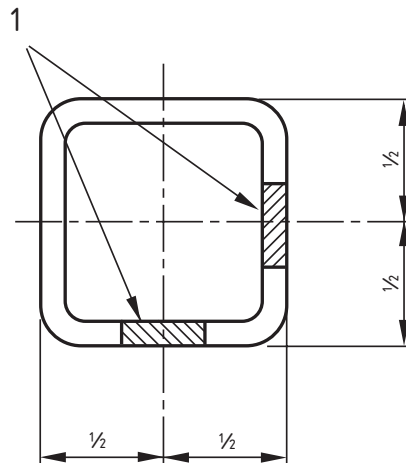

Key

- 1 Alternative positions (on any side except a side containing the weld)

Figure C.2 — Square and rectangular sections

Annex D

(normative)

Evaluation of conformity

D.1 General

The conformity of steel hollow sections to the requirements of this standard and with the stated values (including classes) shall be demonstrated by:

- initial type testing
- factory production control by the manufacturer, including product assessment.

For the purposes of testing, steel hollow sections may be grouped into families, where it is considered that the selected property/properties is/are common to all steel hollow sections within that family.

D.2 Type testing

D.2.1 Initial type testing

D.2.1.1 General

An initial type test is the complete set of tests or other procedures, determining the performance characteristics of samples representative of the product types.

To show conformity with this standard, initial type testing shall be performed on first use of this standard for steel hollow sections being put onto the market.

In addition initial type testing shall be performed:

- at the beginning of the production of a new or modified steel hollow sections design;
- if a change occurs in the feedstock;
- at the beginning of a new or modified method of production;

where this would change significantly one or more of the performance characteristics.

In cases where this would mean assessment of steel hollow sections for which type testing in accordance with this standard had already been performed, the testing frequency may be reduced:

- if it has been established that the performance characteristics have not been affected compared to the steel hollow sections already tested;
- if historical data is available (see D.2.1.3).

D.2.1.2 Characteristics

The assessment of the following performance characteristics is required:

EN 10219-1:2006 (E)

- tolerances on dimensions and shape;
- elongation;
- tensile strength;
- yield strength;
- impact strength;
- weldability (chemical composition).

The following performance characteristics are not subject to initial type testing for the following reasons:

- release of dangerous substances – this may be addressed indirectly by controlling the content of the substance(s) concerned;
- bendability, cold/warm formability – the material is inherently ductile and therefore a specific test for these characteristics is not required;
- fatigue, fracture toughness/brittle strength – these characteristics are controlled by the method of use which is covered by EN 1993-1-1.

D.2.1.3 Use of historical data

Tests previously performed on the same steel hollow sections in accordance with the provisions of this standard (same performance characteristic(s), test method, sampling procedure, system of attestation of conformity, etc.) may be taken into account.

D.2.2 Sampling, testing and conformity criteria

D.2.2.1 Sampling

Initial type testing shall be performed on random samples of steel hollow sections representative of the types of steel hollow sections manufactured.

D.2.2.2 Testing and conformity criteria

The number of steel hollow sections to be tested (or assessed) shall be in accordance with Table D.1.

Table D.1 — Sampling and conformity criteria for type testing of steel hollow sections

Performance characteristic	Requirement clause	Assessment method	Number of tests/samples	Conformity criteria
tolerances on dimensions and shape	EN 10219-2 :2006, Clause 6	EN 10219-2 :2006, Clause 7	one per test unit (see 8.1.3 for definition of test unit)	6.11
elongation	6.7.1, Tables A.3, B.4 and B.5	9.2.2		6.7
tensile strength	6.7.1, Tables A.3, B.4 and B.5	9.2.2		6.7
yield strength	6.7.1, Tables A.3, B.4 and B.5	9.2.2		6.7
impact strength	6.7.2, Tables A.3, B.4 and B.5	9.2.3		6.7
weldability (chemical composition)	6.6, Tables A.1, B.1, B.2 and 6.8.1	9.1		6.6

The results of all type tests shall be recorded and records retained by the manufacturer for at least 5 years.

D.3 Factory production control (FPC)

D.3.1 General

The manufacturer shall establish, document and maintain an FPC system to ensure that the products placed on the market conform to the declared performance characteristics. The FPC system shall consist of written procedures (works' manual), regular inspections and tests and/or assessments and the use of the results to control equipment, feedstock and other incoming material supply, the production process and the product. Records shall remain legible, readily identifiable and retrievable.

An FPC system conforming with the requirements of EN ISO 9001, and made specific to the product and the requirements of this standard, shall be considered to satisfy the above requirements.

The results of inspections, tests or assessments requiring action shall be recorded, as shall any action taken. The action to be taken when control values or criteria are not met shall be recorded and retained for the period specified in the manufacturer's FPC procedures.

D.3.2 FPC requirements for all manufacturers

D.3.2.1 General

The manufacturer shall establish procedures to ensure that the production tolerances allow for the performance characteristics of the steel hollow sections to be in conformity with the declared values derived from initial type testing.

The performance characteristics and the means of verification are:

- elongation, tensile strength and yield strength; tensile test in accordance with EN 10002-1;
- impact strength; impact test in accordance with EN 10045-1;
- weldability; chemical analysis in accordance with the methods listed in CR 10261.

The minimum frequency of testing shall be in accordance with Table D.1.

The manufacturer shall record the results of the tests specified above. These records shall, as a minimum, include the following information:

- identification of the steel hollow sections tested;
- date of sampling and testing;
- tests performed;
- test results.

D.3.3 Manufacturer-specific FPC system requirements

D.3.3.1 Personnel

The responsibility, authority and the relationship between personnel that manages, performs or verifies work affecting product conformity, shall be defined. This applies in particular to personnel that needs to initiate actions preventing product non-conformities from occurring, actions in case of non-conformities and to identify and register product conformity problems. Personnel performing work affecting product conformity shall be competent on the basis of appropriate education, training, skills and experience for which records shall be maintained.

D.3.3.2 Equipment

All weighing, measuring and testing equipment necessary to achieve, or produce evidence of, conformity shall be calibrated or verified and regularly inspected according to documented procedures, frequencies and criteria. Control of monitoring and measuring devices shall comply with the appropriate clause of EN ISO 9001.

All equipment used in the manufacturing process shall be regularly inspected and maintained to ensure use, wear or failure does not cause inconsistency in the manufacturing process.

Inspections and maintenance shall be carried out and recorded in accordance with the manufacturer's written procedures and the records retained for the period defined in the manufacturer's FPC procedures.

D.3.3.3 Design process

The factory production control system shall document the various stages in the design of the steel hollow sections, and identify the checking procedure and those individuals responsible for all stages of design.

During the design process itself, a record shall be kept of all checks, their results, and any corrective actions taken. This record shall be sufficiently detailed and accurate to demonstrate that all stages of the design phase, and all checks, have been carried out satisfactorily. Compliance with EN ISO 9001:2000, 7.3 shall be deemed to satisfy the requirements of this clause.

D.3.3.4 Feedstock and incoming materials

The specifications of all incoming feedstock and materials shall be documented, as shall the inspection scheme for ensuring their conformity. The verification of conformity of the feedstock and incoming materials with their specification shall be in accordance with EN ISO 9001:2000, 7.4.3.

D.3.3.5 In-process control

The manufacturer shall plan and carry out production under controlled conditions. Compliance with EN ISO 9001:2000, 7.5.1 and 7.5.2 shall be deemed to satisfy the requirements of this clause.

D.3.3.6 Traceability and marking

Steel hollow sections shall be identifiable and traceable with regard to their production origin, see Clause 10. The manufacturer shall have written procedures ensuring that processes related to affixing traceability codes and/or markings, see Clause 10, are inspected regularly. Compliance with EN ISO 9001:2000, 7.5.3 shall be deemed to satisfy the requirements of this clause.

D.3.3.7 Non-conforming products

The manufacturer shall have written procedures which specify how non-conforming products shall be dealt with. Any such events shall be recorded as they occur and these records shall be kept for the period defined in the manufacturer's written procedures. Compliance with EN ISO 9001:2000, 8.3 shall be deemed to satisfy the requirements of this clause.

D.3.3.8 Corrective action

The manufacturer shall have documented procedures that instigate action to eliminate the cause of non-conformities in order to prevent recurrence. Compliance with EN ISO 9001:2000, 8.5.2 shall be deemed to satisfy the requirements of this clause.

D.3.3.9 Handling and storage

The manufacturer shall have written procedures stating methods of product handling and shall provide suitable storage areas to prevent damage or deterioration of the product.

Annex ZA (informative)

Clauses of this European Standard addressing the provisions of the EU Construction Products Directive

ZA.1 Scope and relevant characteristics

This European Standard has been prepared under a mandate M120 (Structural Metallic Products and ancillaries) given to CEN by the European Commission and the European Free Trade Association.

The clauses of this European Standard shown in this annex meet the requirements of the mandate given under the EU Construction Products Directive (89/106/EEC).

Compliance with these clauses confers a presumption of fitness of the construction products covered by this annex for the intended uses indicated herein; reference shall be made to the information accompanying the CE marking.

WARNING: Other requirements and other EU Directives, not affecting the fitness for intended use may be applicable to a construction product falling within the scope of this standard.

NOTE 1 In addition to any specific clauses relating to dangerous substances contained in this standard, there may be other requirements applicable to the products falling within its scope (e.g. transposed European legislation and national laws, regulations and administrative provisions). In order to meet the provisions of the EU Construction Products Directive, these requirements need also to be complied with, when and where they apply.

NOTE 2 *An informative database of European and national provisions on dangerous substances is available at the Construction web site on EUROPA (accessed through <http://europa.eu.int/comm/enterprise/construction/internal/dangsub/dangmain.htm>).*

This annex establishes the conditions for the CE marking of the structural hollow sections intended for the uses indicated in Table ZA.1 and shows the relevant clauses applicable.

The scope of this annex is defined by Table ZA.1.

Table ZA.1 — Relevant clauses for product and intended use

Product: Steel hollow sections			
Intended use: To be used in metal structures or in composite metal and concrete structures			
Essential characteristic	Requirement clauses in this European Standard	Levels and/or classes	Notes
Tolerances on dimensions and shape.	EN 10219-2:2006, Clause 6	—	Pass/fail limits are specified in EN 10219-2:2006, Table 2
Elongation	6.7.1, Tables A.3, B.4 and B.5	—	% Values to be achieved are contained in Annexes A and B.
Tensile strength and yield strength	6.7.1, Tables A.3, B.4 and B.5	—	MPa Values to be achieved are contained in Annexes A and B.
Impact strength	6.7.2, Tables A.3, B.4 and B.5	—	J Values to be achieved are contained in Annexes A and B.
Weldability	6.6, Tables A.1, B.1, B.2 and 6.8.1	—	CEV value specified. Tables are in Annexes A and B, formula for calculation is specified.
Durability ^a	6.8.2	—	By option to specify that the product is suitable for galvanizing.
^a Durability (against corrosion) is dependent on the method of protection and/or thickness of coating.			

The requirement on a certain characteristic is not applicable in those Member States (MSs) where there are no regulatory requirements on that characteristic for the intended use of the product. In this case, manufacturers placing their products on the market of these MSs are not obliged to determine nor declare the performance of their products with regard to this characteristic and the option “No performance determined” (NPD) in the information accompanying the CE marking (see Clause ZA.3) may be used. The NPD option may not be used, however, where the characteristic is subject to a threshold level.

ZA.2 Procedure for the attestation of conformity of steel hollow sections

ZA.2.1 System of attestation of conformity

The system of attestation of conformity of steel hollow sections indicated in Table ZA.1, in accordance with the Decision of the Commission (1998/214/EC) of 18 March 1998 as given in the Annex III of the mandate for Structural metallic products and ancillaries is shown in Table ZA.2 for the intended uses and relevant levels or classes.

Table ZA.2 — System of attestation of conformity

Product	Intended use	Level(s) or class(es)	Attestation of conformity system(s)
Steel hollow section	To be used in metal structures or in composite metal and concrete structures.	-	2+
System 2+: See Directive 89/106/EEC (CPD), Annex III.2. (ii), First possibility, including certification of the factory production by an approved body on the basis of its continuous surveillance, assessment and approval.			

The attestation of conformity of the steel hollow section in Table ZA.1 shall be according to the evaluation of conformity procedures indicated in Table ZA.3 resulting from application of the clauses of this European Standard indicated therein.

Table ZA.3 — Assignment of conformity tasks for steel hollow sections under system 2+

Tasks		Content of task	Evaluation of conformity clauses to apply
Tasks under the responsibility of the manufacturer	Factory production control	All parameters related to all characteristics of Table ZA.1	Clause 11 D.3
	Initial type testing	All relevant characteristics of Table ZA.1	Clause 11 D.2
Tasks under the responsibility of the notified body	Certification of factory production control system on the basis of:	Initial inspection of factory and factory production control system	Clause 11 D.3
		Continuous surveillance, assessment and approval of factory production control system	

ZA.2.2 EC Certificate and declaration of conformity

The manufacturer or his agent established in the European Economic Area (EEA), shall prepare and retain a declaration of conformity, which authorises the affixing of the CE marking. This declaration shall include:

- name and address of the manufacturer, or his authorised representative established in the EEA, and the place of production;
- description of the product type (type, identification, use...), and a copy of the information accompanying the CE marking;
- provisions to which the product conforms (e.g. Annex ZA of this European Standard);
- particular conditions applicable to the use of the product (if necessary);
- the number of the accompanying factory production control system certificate;
- name of, and position held by, the person empowered to sign the declaration on behalf of the manufacturer or his authorised representative.

The declaration shall be accompanied by a factory production control system certificate, drawn up by a notified body, which shall contain in addition to the information above, the following:

- name and address of the notified body;
- the number of the factory production control system certificate;
- conditions and period of validity of the certificate, where applicable;
- name of, and position held by, the person empowered to sign the certificate.

This declaration and certificate shall be presented in the official language or language(s) acceptable to the Member State in which the product is to be used.

ZA.3 CE Marking and labelling

The CE marking shall be in accordance with Directive 93/68/EEC²⁾ and be placed on the accompanying commercial documents or inspection document. The CE marking consists of the letters “CE” in the specified form and shall be accompanied by the following information.

- Identification number of the notified body;
- name or identifying mark of the producer;
- the last two digits of the year of marking;
- the number of the EC certificate of conformity and the name or number of the notified body with regard to the factory production control system;
- product designation (see 4.2);
- “No performance determined” for characteristics where this is relevant.

² Council Directive 93/68/EEC of July 1993 amending 12 Directives, including Directive 89/106/EEC harmonising the provisions for the CE marking.

EN 10219-1:2006 (E)

The “No performance determined” (NPD) option may not be used where the characteristic is subject to a threshold level. Otherwise, the NPD option may be used when and where the characteristic, for a given intended use, is not subject to regulatory requirements in the Member State of destination.

Figure ZA.1 gives an example of the information to be given on the product, label, packaging and/or commercial documents.

 01234	<p><i>CE conformity marking, consisting of the “CE”-symbol given in Directive 93/68/EEC.</i></p> <p><i>Identification number of the certification body</i></p>
<p>AnyCo Ltd, PO Box 21, B-1050</p> <p>06</p> <p>01234-CPD-00234</p>	<p><i>Name or identifying mark and registered address of the producer</i></p> <p><i>Last two digits of the year in which the marking was affixed</i></p> <p><i>FPC Certificate number</i></p>
<p>EN 10219-1:2005</p> <p>Cold formed steel hollow sections for building and civil engineering</p> <p>Product designation S355J2H</p> <p>Dangerous substance X : Less than 0,2 ppm</p> <p>Durability: NPD</p> <p>(by coating)</p>	<p><i>No. of European Standard</i></p> <p><i>Description of product and information on regulated characteristics</i></p>

Figure ZA.1 – Example CE marking information

In addition to any specific information relating to dangerous substances shown above, the product should also be accompanied, when and where required and in the appropriate form, by documentation listing any other legislation on dangerous substances for which compliance is claimed, together with any information required by that legislation.

NOTE European legislation without national derogations need not be mentioned.

Bibliography

EN 473, *Non-destructive testing – Qualification and certification of NDT personnel – General principles*

EN 1011-1, *Welding — Recommendations for welding of metallic materials — Part 1: General guidance for arc welding*

EN 1011-2, *Welding — Recommendations for welding of metallic materials — Part 2: Arc welding of ferritic steels*

EN 1993-1-1, *Eurocode 3: Design of steel structures - Part 1-1: General rules and rules for buildings*

EN 10025-2, *Hot rolled products of structural steels — Part 2: Technical delivery conditions for non-alloy structural steels*

EN 10025-3, *Hot rolled products of structural steels — Part 3: Technical delivery conditions for normalized/normalized rolled weldable fine grain structural steels*

Cold formed welded structural hollow sections of non-alloy and fine grain steels —

Part 2: Tolerances, dimensions and sectional properties

The European Standard EN 10219-2:2006 has the status of a
British Standard

ICS 77.140.75

National foreword

This British Standard is the official English language version of EN 10219-2:2006. It supersedes BS EN 10219-2:1997 which is withdrawn.

The UK participation in its preparation was entrusted to Technical Committee ISE/12, Structural steel, which has the responsibility to:

- aid enquirers to understand the text;
- present to the responsible international/European committee any enquiries on the interpretation, or proposals for change, and keep UK interests informed;
- monitor related international and European developments and promulgate them in the UK.

A list of organizations represented on this committee can be obtained on request to its secretary.

Cross-references

The British Standards which implement international or European publications referred to in this document may be found in the *BSI Catalogue* under the section entitled “International Standards Correspondence Index”, or by using the “Search” facility of the *BSI Electronic Catalogue* or of British Standards Online.

This publication does not purport to include all the necessary provisions of a contract. Users are responsible for its correct application.

Compliance with a British Standard does not of itself confer immunity from legal obligations.

Summary of pages

This document comprises a front cover, an inside front cover, the EN title page, pages 2 to 36, an inside back cover and a back cover.

The BSI copyright notice displayed in this document indicates when the document was last issued.

Amendments issued since publication

Amd. No.	Date	Comments

This British Standard was published under the authority of the Standards Policy and Strategy Committee on 31 May 2006

© BSI 2006

ISBN 0 580 48464 5

English Version

Cold formed welded structural hollow sections of non-alloy and fine grain steels - Part 2: Tolerances, dimensions and sectional properties

Profils creux pour la construction soudés, formés à froid en aciers non alliés et à grains fins - Partie 2 : Tolérances, dimensions et caractéristiques de profil

Kaltgefertigte geschweißte Hohlprofile für den Stahlbau aus unlegierten Baustählen und aus Feinkornbaustählen - Teil 2: Grenzabmaße, Maße und statische Werte

This European Standard was approved by CEN on 16 March 2006.

CEN members are bound to comply with the CEN/CENELEC Internal Regulations which stipulate the conditions for giving this European Standard the status of a national standard without any alteration. Up-to-date lists and bibliographical references concerning such national standards may be obtained on application to the Central Secretariat or to any CEN member.

This European Standard exists in three official versions (English, French, German). A version in any other language made by translation under the responsibility of a CEN member into its own language and notified to the Central Secretariat has the same status as the official versions.

CEN members are the national standards bodies of Austria, Belgium, Cyprus, Czech Republic, Denmark, Estonia, Finland, France, Germany, Greece, Hungary, Iceland, Ireland, Italy, Latvia, Lithuania, Luxembourg, Malta, Netherlands, Norway, Poland, Portugal, Romania, Slovakia, Slovenia, Spain, Sweden, Switzerland and United Kingdom.



EUROPEAN COMMITTEE FOR STANDARDIZATION
COMITÉ EUROPÉEN DE NORMALISATION
EUROPÄISCHES KOMITEE FÜR NORMUNG

Management Centre: rue de Stassart, 36 B-1050 Brussels

Contents

Foreword	3
1 Scope	4
2 Normative references	4
3 Terms and definitions	4
4 Symbols	4
5 Information to be obtained by the manufacturer	5
6 Tolerances	5
7 Measurement of size and shape	8
7.1 General	8
7.2 Outside dimensions	8
7.3 Thickness	8
7.4 Out-of-roundness	9
7.5 Concavity and convexity	9
7.6 Squareness of sides	10
7.7 External corner profile	11
7.8 Twist	11
7.9 Straightness	12
8 Dimensions and sectional properties	12
Annex A (informative) Additional tolerances for piling tube	14
A.1 General	14
A.2 Out of roundness tolerance	14
A.3 Accidental eccentricity tolerance	15
A.4 Dimple tolerance	17
Annex B (normative) Formulae for the calculation of sectional properties	20
B.1 General	20
B.2 Circular hollow sections	20
B.3 Rectangular, or square, hollow sections	21
Annex C (normative) Sectional properties for a limited range of standard sizes	24
Bibliography	36

Foreword

This European Standard (EN 10219-2:2006) has been prepared by Technical Committee ECISS/TC 10 “Structural steels - Grades and qualities”, the secretariat of which is held by NEN.

This European Standard shall be given the status of a national standard, either by publication of an identical text or by endorsement, at the latest by October 2006, and conflicting national standards shall be withdrawn at the latest by October 2006.

This European Standard supersedes EN 10219—2:1997.

This standard consists of the following parts under the general title 'Cold formed welded structural hollow sections of non-alloy and fine grain steels':

- Part 1: Technical delivery conditions
- Part 2: Tolerances, dimensions and sectional properties

It forms part of a series of standards on hollow sections together with EN 10210-1 and 2, which are also under revision.

According to the CEN/CENELEC Internal Regulations, the national standards organizations of the following countries are bound to implement this European Standard: Austria, Belgium, Cyprus, Czech Republic, Denmark, Estonia, Finland, France, Germany, Greece, Hungary, Iceland, Ireland, Italy, Latvia, Lithuania, Luxembourg, Malta, Netherlands, Norway, Poland, Portugal, Romania, Slovakia, Slovenia, Spain, Sweden, Switzerland and United Kingdom.

1 Scope

This part of EN 10219 specifies tolerances for cold formed welded circular, square and rectangular structural hollow sections, manufactured in wall thicknesses up to 40 mm, in the following size ranges:

Circular: Outside diameters up to 2 500 mm

Square: Outside dimensions up to 500 mm x 500 mm

Rectangular: Outside dimensions up to 500 mm x 300 mm

The formulae for calculating sectional properties of sections manufactured to the dimensional tolerances of this standard, to be used for the purposes of structural design, are given in Annex B.

Dimensions and sectional properties for a limited range of sizes are given in Annex C.

Technical delivery conditions are specified in EN 10219-1.

NOTE The designation of the sections' major axis (yy) and its minor axis (zz) align with the axis designation used for structural design in the structural Eurocodes.

2 Normative references

The following referenced documents are indispensable for the application of this European Standard. For dated references, only the edition cited applies. For undated references, the latest edition of the referenced document (including any amendments) applies.

EN 10219-1:2006, *Cold formed welded structural hollow sections of non-alloy and fine grain steels — Part 1: Technical delivery conditions*

3 Terms and definitions

For the purposes of this European Standard, the terms and definitions given in EN 10219-1:2006 apply.

4 Symbols

For the purposes of this European Standard, the symbols defined in Table 1 apply.

Table 1 — Symbols and definitions

Symbol	Unit	Definition
A	cm ²	Cross-sectional area
A_s	m ² /m	Superficial area per metre length
B	mm	Specified side dimension of a square hollow section. Specified dimension of the shorter side of a rectangular hollow section
C_1/C_2	mm	Length of corner region of a square or rectangular hollow section
C_t	cm ³	Torsional modulus constant
D	mm	Specified outside diameter of a circular hollow section
D_{max}/D_{min}	mm	The maximum and minimum outside diameter of a circular hollow section measured in the same plane
e	mm	Deviation from straightness
H	mm	Specified dimension of the longer side of a rectangular hollow section
I	cm ⁴	Second moment of area
I_t	cm ⁴	Torsional inertia constant (polar moment of inertia in the case of circular hollow sections only)
i	cm	Radius of gyration
L	mm	Length
M	kg/m	Mass per unit length
O	%	Out-of-roundness
R	mm	External corner radius of a square or rectangular hollow section
T	mm	Specified thickness
V	mm	Total measured twist
V_1	mm	Twist measured at one end of a section
W_{el}	cm ³	Elastic section modulus
W_{pl}	cm ³	Plastic section modulus
x_1	mm	Concavity of a side of a square or rectangular hollow section
x_2	mm	Convexity of a side of a square or rectangular hollow section
yy	—	Axis of cross-section, major axis of a rectangular hollow section
zz	—	Axis of cross-section, minor axis of a rectangular hollow section
θ	°	Angle between adjacent sides of a square or rectangular hollow section

5 Information to be obtained by the manufacturer

The following mandatory information from this part of EN 10219 shall be obtained by the manufacturer at the time of enquiry and order.

- a) The type of length, length range or length (see Table 4).
- b) The dimensions (see Clause 8).

NOTE This information is included in the list of information to be obtained by the manufacturer contained in EN 10219-1.

6 Tolerances

6.1 Tolerances shall not exceed the values given in Table 2 for shape and mass, Table 3 for external corner profiles, Table 4 for manufacturer's delivered length and Table 5 for the height of the internal and external weld bead of submerged arc welded hollow sections.

6.2 The internal corners of square and rectangular hollow sections shall be rounded.

NOTE The internal corner profile is not specified.

6.3 Additional tolerances for out-of-roundness, accidental eccentricity and dimples may be applied to tubes of diameter ≥ 900 mm and $D/T \geq 50$ when they are to be used as bearing piles or primary elements in combined walls in accordance with ENV 1993-5. In order for these additional tolerances to be applied the fabrication tolerance quality class, A, B, or C should be agreed. See Annex A.

Table 2 — Tolerances on shape and mass

Characteristic	Circular hollow sections	Square and rectangular hollow sections	
		Side length mm	Tolerance
Outside dimensions (D , B and H)	$\pm 1\%$ with a minimum of $\pm 0,5$ mm and a maximum of ± 10 mm		
		$H, B < 100$	$\pm 1\%$ with a minimum of $\pm 0,5$ mm
		$100 \leq H, B \leq 200$	$\pm 0,8\%$
		$H, B > 200$	$\pm 0,6\%$
Thickness (T)	For $D \leq 406,4$ mm: $T \leq 5$ mm $\pm 10\%$ $T > 5$ mm $\pm 0,5$ mm For $D > 406,4$ mm: $\pm 10\%$ with a maximum of ± 2 mm	$T \leq 5$ mm $\pm 10\%$ $T > 5$ mm $\pm 0,5$ mm	
Out-of-roundness (O)	2 % for hollow sections having a diameter to thickness ratio not exceeding 100 ^a	—	
Concavity/convexity (x_1, x_2) ^b	—	Max. 0,8 % with a minimum of 0,5 mm	
Squareness of side (θ)	—	$90^\circ \pm 1^\circ$	
External corner profile (C_1, C_2 or R)	—	See Table 3	
Twist (V)	—	2 mm plus 0,5 mm/m length	
Straightness (e)	0,20 % of total length and 3 mm over any 1 m length	0,15 % of total length and 3 mm over any 1 m length	
Mass per unit length (M)	$\pm 6\%$ on individual delivered lengths		
<p>^a Where the diameter to thickness ratio exceeds 100 the tolerance on out-of-roundness shall be agreed.</p> <p>^b The tolerance on convexity and concavity is independent of the tolerance on outside dimensions.</p>			

Table 3 — Tolerances on external corner profiles

Dimensions in millimetres

Thickness T	External corner profile C_1, C_2 or R^a
$T \leq 6$	1,6 T to 2,4 T
$6 < T \leq 10$	2,0 T to 3,0 T
$10 < T$	2,4 T to 3,6 T
^a The sides need not be tangential to the corner arcs.	

Table 4 — Tolerances on manufacturer's delivered length

Dimensions in millimetres

Type of length ^a	Range of length or length L	Tolerance
Random length	4 000 < L ≤ 16 000 with a range of 2 000 per order item	10 % of sections supplied may be below the minimum for the ordered range but not shorter than 75 % of the minimum range length
Approximate length	≥ 4 000	$^{+50}_0$ mm
Exact length ^b	<6 000	$^{+5}_0$ mm
	6 000 ≤ L ≤ 10 000	$^{+15}_0$ mm
	>10 000	$^{+5}_0$ mm +1 mm/m
^a The manufacturer shall establish at the time of enquiry and order the type of length required and the length range or length.		
^b Common lengths available are 6 m and 12 m.		

Table 5 — Tolerance on height of internal and external weld bead for submerged arc welded hollow sections

Dimensions in millimetres

Thickness, T	Maximum weld bead height
$\leq 14,2$	3,5
$> 14,2$	4,8

7 Measurement of size and shape

7.1 General

All external dimensions, including out-of-roundness, shall be measured at a distance from the end of the hollow section of not less than D for circular sections, B for square sections or H for rectangular sections, with a minimum of 100 mm.

7.2 Outside dimensions

For circular hollow sections the diameter (D) shall be measured either directly, e.g. using a calliper gauge, or by circumference tape at the discretion of the manufacturer.

The limiting cross-sectional positions for measuring B and H for square and rectangular hollow sections are shown in Figure 1.

7.3 Thickness

The thickness (T) shall be measured at a position not less than $2T$ from the weld.

The limiting cross-sectional positions for measuring the thickness of square and rectangular hollow sections are shown in Figure 1.

NOTE Thickness is normally measured within a distance of half the outside diameter or half the dimension of the longer side from the end of the section.

Dimensions in millimetres

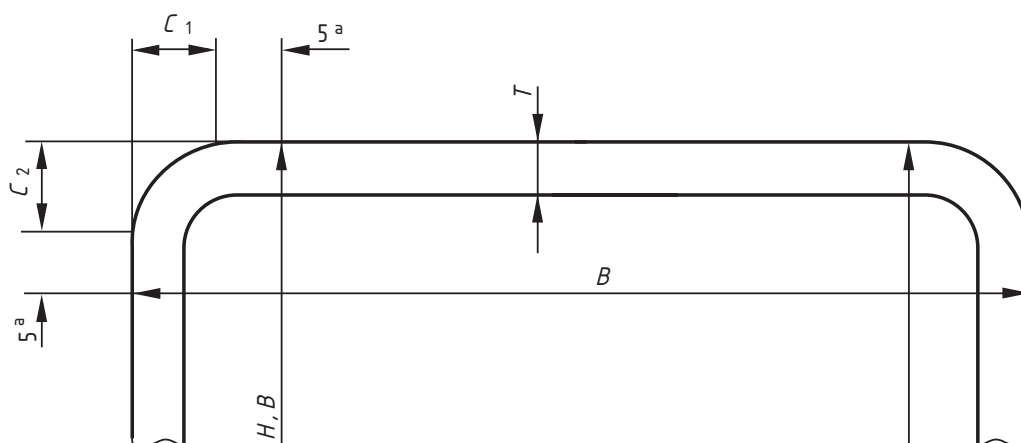

^a This dimension is a maximum when measuring B or H and a minimum when measuring T .

Figure 1 — Limiting cross-sectional positions for measuring the dimensions B , H and T for square or rectangular hollow sections

7.4 Out-of-roundness

The out-of-roundness (O) of a circular hollow section shall be calculated from the following equation, but see Annex A for piling tube.

$$O(\%) = \frac{D_{\max} - D_{\min}}{D} \times 100$$

7.5 Concavity and convexity

The concavity (x_1) or the convexity (x_2) of the sides of a square or rectangular hollow section shall be measured as shown in Figure 2.

The percentage concavity or convexity shall be calculated as follows:

$$\frac{x_1}{B} \times 100\%; \frac{x_2}{B} \times 100\%; \frac{x_1}{H} \times 100\%; \frac{x_2}{H} \times 100\%$$

where B and H are the dimensions of the sides containing the concavity x_1 or the convexity x_2 .

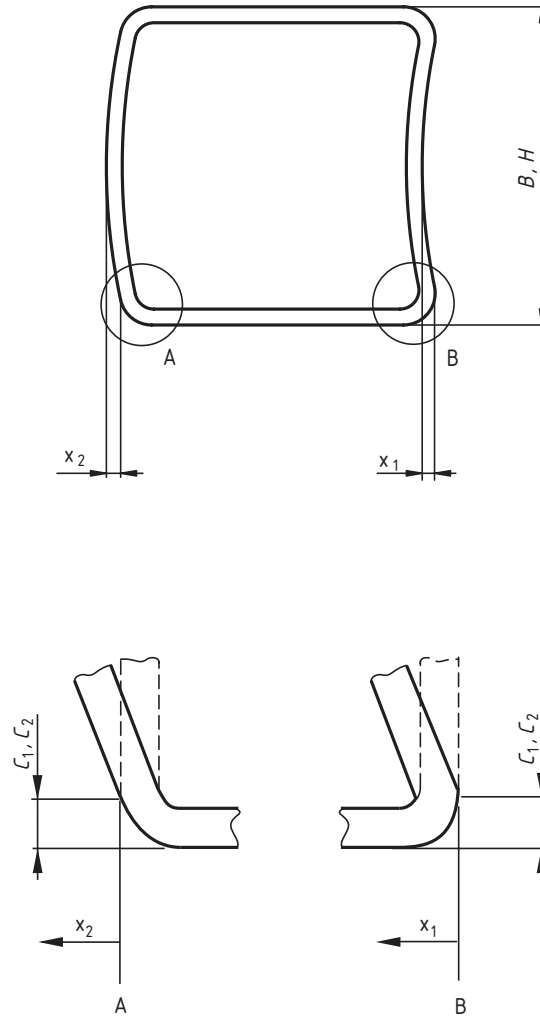

Figure 2 — Measurement of concavity/convexity of square or rectangular hollow sections

7.6 Squareness of sides

The deviation from squareness of the sides of a square or rectangular hollow section shall be measured as the difference between 90° and θ as shown in Figure 3.

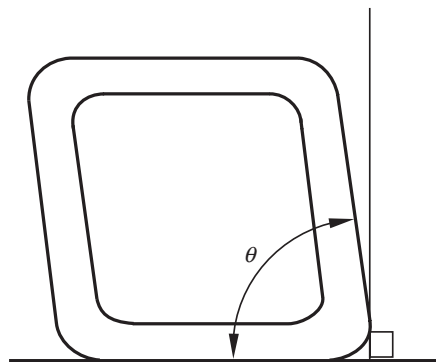

Figure 3 — Squareness of sides of square or rectangular hollow sections

7.7 External corner profile

7.7.1 The external corner profile of a square or rectangular hollow section shall be measured according to 7.7.2 or 7.7.3 at the discretion of the manufacturer.

7.7.2 The corner arc shall be measured with a radius gauge.

7.7.3 The distance between the intersection of the flat side and the corner arc and the intersection of the projections of the flat sides to the corner (C_1 and C_2 in Figure 4) shall be measured.

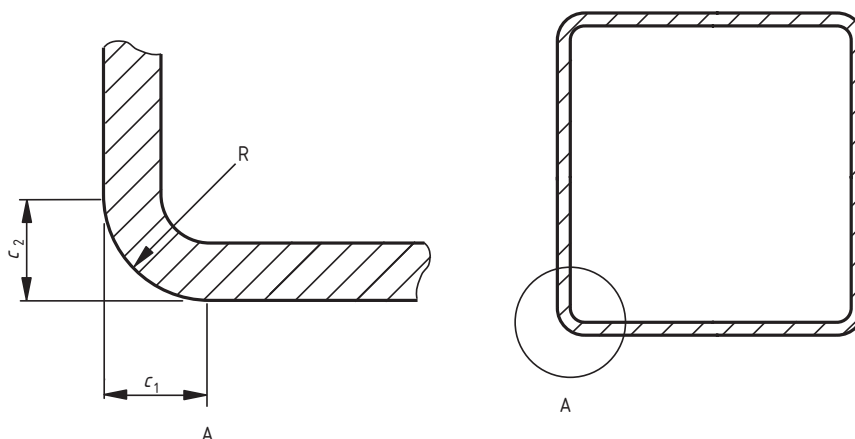

Figure 4 — Outside corner profile of square or rectangular hollow sections

7.8 Twist

7.8.1 The twist (V) in a square or rectangular hollow section shall be determined in accordance with 7.8.2 or 7.8.3 at the discretion of the manufacturer.

7.8.2 The hollow section shall be placed on a horizontal surface with one side at one end pressed flat against the surface. At the opposite end of the hollow section the difference in height of the two lower corners from the horizontal surface (see Figure 5) shall be determined.

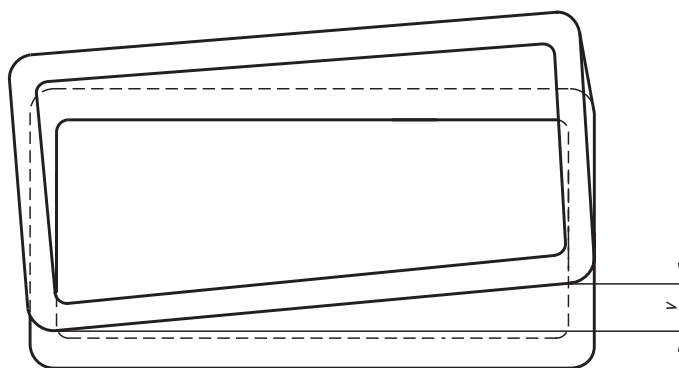
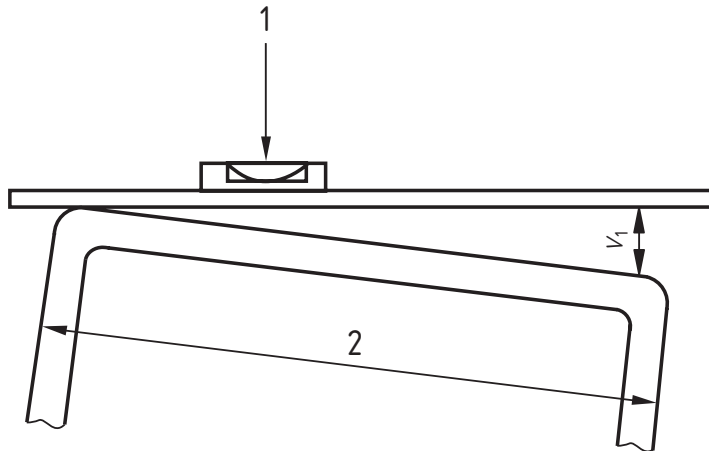

Figure 5 — Twist of square or rectangular hollow sections

7.8.3 The twist shall be measured with a spirit level and micrometer gauge (screw). The reference length of the spirit level shall be the distance between the intersection of the flat sides and the corner arcs (see Figure 6). The twist V is the difference between the values V_1 (see Figure 6) measured at each end of the hollow section.



Key

- 1 Spirit level
- 2 H for rectangular sections, B for square sections

Figure 6 — Measurement of twist

7.9 Straightness

The deviation from straightness (e) of the total length of a hollow section shall be measured at the point of maximum departure of the hollow section from a straight line connecting its two ends, as shown in Figure 7 where L is the manufacturer's delivered length. The percentage deviation from straightness shall be calculated as follows:

$$\frac{e}{L} \times 100\%$$

In addition the local deviation (e) from straightness of a hollow section, measured at any point along its length from a straight line length L of 1 m, shall be not more than 3 mm.

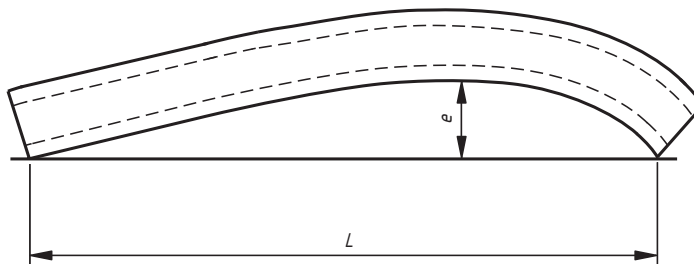

Figure 7 — Measurement of deviation from straightness

8 Dimensions and sectional properties

The nominal sectional properties of hollow sections within the scope of this part of EN 10219 and manufactured to the dimensional tolerances of this standard, required for the purposes of structural design, shall be calculated in accordance with Annex B.

The sectional properties for a limited range of standard sizes of cold formed hollow sections are given in Table C.1 for circular sections, Table C.2 for square sections and Table C.3 for rectangular sections. These sectional properties were calculated from the formulae given in Annex B.

NOTE Not all sizes and thicknesses shown in Tables C.1, C.2 and C.3 are available from all manufacturers and the user is recommended to check availability. Other sizes and thicknesses within the scope of this standard may be available.

Annex A (informative)

Additional tolerances for piling tube

A.1 General

This annex contains guidance on additional tolerances that can be applied to tubes when they are to be used as bearing piles or primary elements in combined walls in accordance with ENV 1993-5. These requirements are generally relevant to tubes of diameter ≥ 900 mm and $D/T \geq 100$.

For verification of tubular piles subject to shell buckling, ENV 1993-5: Piling refers to ENV 1993-1-6. Shell buckling is partly governed by geometrical imperfections of the shell due to out-of-roundness, accidental eccentricity and dimples. ENV 1993-1-6 specifies limits for each of these geometrical imperfections, based on the concept of fabrication quality classes. Details of how to assess out-of-roundness, accidental eccentricity and dimples, and the recommended maximum permitted values for each fabrication quality class, are given in A.2, A.3 and A.4.

NOTE 1 See ENV 1993-1-6 for further details of fabrication tolerance quality classes, their design implications and for definitions and use of symbols.

NOTE 2 The values of certain parameters, given in Tables A.1, A.2 and A.3 may be subject to change by national application of ENV 1993-1-6. Nationally determined parameters will be given in the relevant National Annex of ENV 1993-1-6.

A.2 Out of roundness tolerance

Out-of-roundness of a tubular pile is assessed in terms of the parameter U_r , the difference between the maximum and minimum values of the measured internal diameter, relative to the nominal inside diameter, see Figure A.1, given by:

$$U_r = \frac{d_{\max} - d_{\min}}{d_{\text{nom}}}$$

Where:

- d_{\max} is the maximum measured internal diameter;
- d_{\min} is the minimum measured internal diameter;
- d_{nom} is the nominal inside diameter ($d = D - 2T$, see B.2).

An appropriate number of diameters should be measured in order to identify the maximum and minimum values.

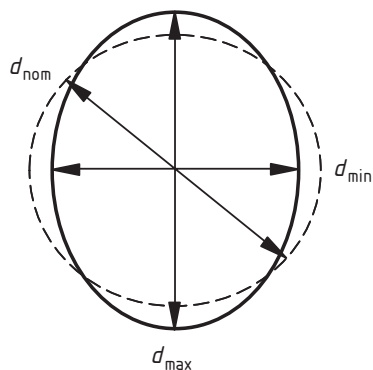

Figure A.1 — Assessment of d_{\min} and d_{\max} and relationship to d

The out-of-roundness parameter U_r should satisfy the condition:

$$U_r \leq U_{r, \max}$$

where:

$U_{r, \max}$ is the maximum permitted value for the out-of-roundness parameter.

Recommended values for each fabrication tolerance quality class are given in Table A.1.

Table A.1 — Maximum permitted values for out-of-roundness parameter $U_{r, \max}$

Dimensions in mm

Fabrication tolerance quality class	Description	Diameter range		
		$d \leq 500$	$500 < d < 1250$	$1250 \leq d$
		Value of $U_r \max^a$		
Class A	Excellent	0,14	$0,007 + 0,0093 (1,25 - d)$	0,007
Class B	High	0,02	$0,010 + 0,0133 (1,25 - d)$	0,01
Class C	Normal	0,03	$0,015 + 0,020 (1,25 - d)$	0,015

^a The values of this parameter may be subject to change by national application of ENV 1993-1-6. If in doubt, reference should be made to the relevant National Annex of ENV 1993-1-6.

A.3 Accidental eccentricity tolerance

Accidental eccentricity, the unintentional eccentricity due to misalignment of the tube walls at horizontal joints, is assessed in terms of the parameter U_e given by:

$$U_e = \frac{e_a}{T}$$

where:

- e_a is the accidental eccentricity between the mid points of the tube walls at the joint, compared to their normal thickness;
- T is the tube wall thickness.

NOTE For joints involving tubes of different thicknesses, it is recommended to refer to ENV 1993-1-6.

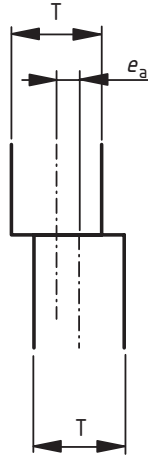

Figure A.2 — Measurement of tube wall eccentricity (e_a)

The accidental eccentricity e_a should satisfy the condition:

$$e_a \leq e_{a, \max}$$

where:

$e_{a, \max}$ is the maximum permitted accidental eccentricity.

Recommended values for each fabrication tolerance quality class are given in Table A.2.

The accidental eccentricity parameter U_e should satisfy the condition:

$$U_e \leq U_{e, \max}$$

where:

$U_{e, \max}$ is the maximum permitted value for the accidental eccentricity parameter.

Recommended values for each fabrication tolerance quality class are given in Table A.2.

Table A.2 — Maximum permitted values for accidental eccentricity parameter $U_{e, \max}$ and for accidental eccentricity $e_{a, \max}$

Dimensions in mm

Fabrication tolerance quality class	Description	$U_{e, \max}^a$	$e_{a, \max}^a$
Class A	Excellent	0,14	2
Class B	High	0,2	3
Class C	Normal	0,3	4
^a The values of these parameters may be subject to change by national application of ENV 1993-1-6. If in doubt, reference should be made to the relevant National Annex of ENV 1993-1-6.			

A.4 Dimple tolerance

The depth of initial dimples in the tube wall w_0 is measured, in both the meridional and circumferential directions, using a measurement gauge, see Figure A.3, of length l_g where:

- a) meridionally and circumferentially $l_g = 4\sqrt{rT}$
- b) across welds $l_g = 25 T$ but $l_g \leq 500$ mm

The gauge used for meridional measurements should be straight but that used for measurements in the circumferential direction should have a radius of curvature r where:

$$r = \frac{(D-T)}{2}$$

NOTE For joints involving tubes of different thicknesses, it is recommended to refer to ENV 1993-1-6.

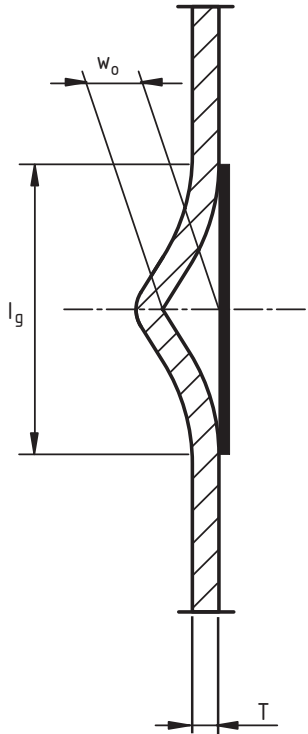

Figure A.3 — Measurement of depth w_o of initial dimples

The level of initial dimples in the wall of the tubular pile is assessed in terms of the dimple tolerance parameter U_d given by:

$$U_d = \frac{w_o}{l_g}$$

The dimple tolerance parameter U_d should satisfy the condition:

$$U_d \leq U_{d, \max}$$

where:

$U_{d, \max}$ is the maximum permitted value for the dimple tolerance parameter.

Recommended values for each fabrication tolerance class are given in Table A.3.

Table A.3 — Maximum permitted values for dimple tolerance parameter $U_{d, \max}$
Dimensions in mm

Fabrication tolerance quality class	Description	$U_{d, \max}$
Class A	Excellent	0,006
Class B	High	0,01
Class C	Normal	0,016

^a The values of this parameter may be subject to change by national application of ENV 1993-1-6. If in doubt, reference should be made to the National Annex of ENV 1993-1-6.

Annex B (normative)

Formulae for the calculation of sectional properties

B.1 General

Tables C.1, C.2 and C.3 of this standard give nominal sectional properties for a limited range of sizes of cold formed hollow sections. The nominal sectional properties of hollow sections supplied to the requirements of this standard shall be calculated using the formulae given below.

NOTE The designation of the sections' major axis (yy) and its minor axis (zz) align with the axis designation used for structural design in the structural Eurocodes. This is a change from previous axis designations.

B.2 Circular hollow sections

The sectional properties for circular hollow sections in Table C.1 are calculated using the formulae given below.

Specified outside diameter	(D)	(mm)
Specified thickness	(T)	(mm)
Inside diameter	$(d = D - 2T)$	(mm)

These parameters, which characterize the shape of circular hollow sections, may vary within the tolerances allowed by this standard and the sectional properties still remain valid.

Superficial area per metre length	$A_s = \frac{\pi D}{10^3}$	(m ² /m)
Cross-sectional area	$A = \frac{\pi(D^2 - d^2)}{4 \times 10^2}$	(cm ²)
Mass per unit length	$M = 0,785 \times A$	(kg/m)
Second moment of area	$I = \frac{\pi(D^4 - d^4)}{64 \times 10^4}$	(cm ⁴)
Radius of gyration	$i = \sqrt{\frac{I}{A}}$	(cm)

Elastic section modulus	$W_{el} = \frac{2I \times 10}{D}$	(cm ³)
Plastic section modulus	$W_{pl} = \frac{D^3 - d^3}{6 \times 10^3}$	(cm ³)
Torsional inertia constant (polar moment of inertia)	$I_t = 2I$	(cm ⁴)
Torsional modulus constant	$C_t = 2W_{el}$	(cm ³)

B.3 Rectangular, or square, hollow sections

The sectional properties for square hollow sections in Table C.2 and for rectangular hollow sections in Table C.3 are calculated using the formulae given below.

Specified side dimension of a square hollow section or shorter side of a rectangular hollow section (B) (mm)

Specified dimension of the longer side of a rectangular hollow section (H) (mm)

Specified thickness (T) (mm)

External corner radius (r_o) for calculation is:

for thicknesses ≤ 6 mm 2,0 T (mm)

for thicknesses > 6 mm ≤ 10 mm 2,5 T (mm)

for thicknesses > 10 mm 3,0 T (mm)

Internal corner radius (r_i) for calculation is:

for thicknesses ≤ 6 mm 1,0 T (mm)

for thicknesses > 6 mm and ≤ 10 mm 1,5 T (mm)

for thicknesses > 10 mm 2,0 T (mm)

These parameters, which characterize the geometric shape of rectangular, or square, hollow sections, may vary within the tolerances allowed by this standard and the sectional properties still remain valid.

Superficial area per metre length $A_s = \frac{2}{10^3} (H + B - 4r_o + \pi r_o)$ (m²/m)

Cross-sectional area

$$A = \frac{2T(B + H - 2T) - (4 - \pi)(r_o^2 - r_i^2)}{10^2} \quad (\text{cm}^2)$$

Mass per unit length

$$M = 0,785A \quad (\text{kg/m})$$

Second moment of area

Major axis

$$I_{yy} = \frac{1}{10^4} \left[\frac{BH^3}{12} - \frac{(B-2T)(H-2T)^3}{12} - 4(I_g + A_g h_g^2) + 4(I_{\xi\xi} + A_\xi h_\xi^2) \right] \quad (\text{cm}^4)$$

Minor axis

$$I_{zz} = \frac{1}{10^4} \left[\frac{HB^3}{12} - \frac{(H-2T)(B-2T)^3}{12} - 4(I_g + A_g h_g^2) + 4(I_{\xi\xi} + A_\xi h_\xi^2) \right] \quad (\text{cm}^4)$$

Radius of gyration

Major axis

$$i_{yy} = \sqrt{\frac{I_{yy}}{A}} \quad (\text{cm})$$

Minor axis

$$i_{zz} = \sqrt{\frac{I_{zz}}{A}} \quad (\text{cm})$$

Elastic section modulus

Major axis

$$W_{el yy} = \frac{2I_{yy}}{H} \times 10 \quad (\text{cm}^3)$$

Minor axis

$$W_{el zz} = \frac{2I_{zz}}{B} \times 10 \quad (\text{cm}^3)$$

Plastic section modulus

Major axis

$$W_{pl yy} = \frac{1}{10^3} \left[\frac{BH^2}{4} - \frac{(B-2T)(H-2T)^2}{4} - 4(A_g h_g) + 4(A_\xi h_\xi) \right] \quad (\text{cm}^3)$$

Minor axis

$$W_{pl zz} = \frac{1}{10^3} \left[\frac{HB^2}{4} - \frac{(H-2T)(B-2T)^2}{4} - 4(A_g h_g) + 4(A_\xi h_\xi) \right] \quad (\text{cm}^3)$$

Torsional inertia constant $I_t = \frac{1}{10^4} \left[T^3 \frac{h}{3} + 2KA_h \right]$ (cm⁴)

Torsional modulus constant $C_t = 10 \left[\frac{I_t}{T + K/T} \right]$ (cm³)

Where $A_g = \left(1 - \frac{\pi}{4} \right) r_o^2$ (mm²)

$$A_\xi = \left(1 - \frac{\pi}{4} \right) r_i^2 \quad (\text{mm}^2)$$

Major axis $h_g = \frac{H}{2} - \left(\frac{10 - 3\pi}{12 - 3\pi} \right) r_o$ (mm)

(For minor axis substitute B for H .)

Major axis $h_\xi = \frac{H - 2T}{2} - \left(\frac{10 - 3\pi}{12 - 3\pi} \right) r_i$ (mm)

(For minor axis substitute B for H .)

$$I_g = \left(\frac{1}{3} - \frac{\pi}{16} - \frac{1}{3(12 - 3\pi)} \right) r_o^4 \quad (\text{mm}^4)$$

$$I_{\xi\xi} = \left(\frac{1}{3} - \frac{\pi}{16} - \frac{1}{3(12 - 3\pi)} \right) r_i^4 \quad (\text{mm}^4)$$

$$h = 2[(B - T) + (H - T)] - 2R_c(4 - \pi) \quad (\text{mm})$$

$$A_h = (B - T)(H - T) - R_c^2(4 - \pi) \quad (\text{mm})$$

$$K = \frac{2A_h T}{h} \quad (\text{mm}^2)$$

$$R_c = \frac{r_o + r_i}{2} \quad (\text{mm})$$

Annex C (normative)

Sectional properties for a limited range of standard sizes

Table C.1 — Nominal dimensions and sectional properties of a limited range of circular hollow sections (see Figure C.1)

Specified outside diameter	Specified thickness	Mass per unit length	Cross-sectional area	Second moment of area	Radius of gyration	Elastic section modulus	Plastic section modulus	Torsional inertia constant	Torsional modulus constant	Superficial area per metre length	Nominal length per tonne
D	T	M	A	I	i	W_{el}	W_{pl}	L_t	C_t	A_s	
mm	mm	kg/m	cm ²	cm ⁴	cm	cm ³	cm ³	cm ⁴	cm ³	m ² /m	m
21,3	2,0	0,95	1,21	0,571	0,686	0,536	0,748	1,14	1,07	0,067	1050
21,3	2,5	1,16	1,48	0,664	0,671	0,623	0,889	1,33	1,25	0,067	863
21,3	3,0	1,35	1,72	0,741	0,656	0,696	1,01	1,48	1,39	0,067	739
26,9	2,0	1,23	1,56	1,22	0,883	0,907	1,24	2,44	1,81	0,085	814
26,9	2,5	1,50	1,92	1,44	0,867	1,07	1,49	2,88	2,14	0,085	665
26,9	3,0	1,77	2,25	1,63	0,852	1,21	1,72	3,27	2,43	0,085	566
33,7	2,0	1,56	1,99	2,51	1,12	1,49	2,01	5,02	2,98	0,106	640
33,7	2,5	1,92	2,45	3,00	1,11	1,78	2,44	6,00	3,56	0,106	520
33,7	3,0	2,27	2,89	3,44	1,09	2,04	2,84	6,88	4,08	0,106	440
42,4	2,0	1,99	2,54	5,19	1,43	2,45	3,27	10,4	4,90	0,133	502
42,4	2,5	2,46	3,13	6,26	1,41	2,95	3,99	12,5	5,91	0,133	407
42,4	3,0	2,91	3,71	7,25	1,40	3,42	4,67	14,5	6,84	0,133	343
42,4	4,0	3,79	4,83	8,99	1,36	4,24	5,92	18,0	8,48	0,133	264
48,3	2,0	2,28	2,91	7,81	1,64	3,23	4,29	15,6	6,47	0,152	438
48,3	2,5	2,82	3,60	9,46	1,62	3,92	5,25	18,9	7,83	0,152	354
48,3	3,0	3,35	4,27	11,0	1,61	4,55	6,17	22,0	9,11	0,152	298
48,3	4,0	4,37	5,57	13,8	1,57	5,70	7,87	27,5	11,4	0,152	229
48,3	5,0	5,34	6,80	16,2	1,54	6,69	9,42	32,3	13,4	0,152	187
60,3	2,0	2,88	3,66	15,6	2,06	5,17	6,80	31,2	10,3	0,189	348
60,3	2,5	3,56	4,54	19,0	2,05	6,30	8,36	38,0	12,6	0,189	281
60,3	3,0	4,24	5,40	22,2	2,03	7,37	9,86	44,4	14,7	0,189	236
60,3	4,0	5,55	7,07	28,2	2,00	9,34	12,7	56,3	18,7	0,189	180
60,3	5,0	6,82	8,69	33,5	1,96	11,1	15,3	67,0	22,2	0,189	147
76,1	2,0	3,65	4,66	32,0	2,62	8,40	11,0	64,0	16,8	0,239	274
76,1	2,5	4,54	5,78	39,2	2,60	10,3	13,5	78,4	20,6	0,239	220
76,1	3,0	5,41	6,89	46,1	2,59	12,1	16,0	92,2	24,2	0,239	185
76,1	4,0	7,11	9,06	59,1	2,55	15,5	20,8	118	31,0	0,239	141
76,1	5,0	8,77	11,2	70,9	2,52	18,6	25,3	142	37,3	0,239	114
76,1	6,0	10,4	13,2	81,8	2,49	21,5	29,6	164	43,0	0,239	96,4
76,1	6,3	10,8	13,8	84,8	2,48	22,3	30,8	170	44,6	0,239	92,2
88,9	2,0	4,29	5,46	51,6	3,07	11,6	15,1	103	23,2	0,279	233
88,9	2,5	5,33	6,79	63,4	3,06	14,3	18,7	127	28,5	0,279	188
88,9	3,0	6,36	8,10	74,8	3,04	16,8	22,1	150	33,6	0,279	157
88,9	4,0	8,38	10,7	96,3	3,00	21,7	28,9	193	43,3	0,279	119
88,9	5,0	10,3	13,2	116	2,97	26,2	35,2	233	52,4	0,279	96,7
88,9	6,0	12,3	15,6	135	2,94	30,4	41,3	270	60,7	0,279	81,5
88,9	6,3	12,8	16,3	140	2,93	31,5	43,1	280	63,1	0,279	77,9
101,6	2,0	4,91	6,26	77,6	3,52	15,3	19,8	155	30,6	0,319	204
101,6	2,5	6,11	7,78	95,6	3,50	18,8	24,6	191	37,6	0,319	164
101,6	3,0	7,29	9,29	113	3,49	22,3	29,2	226	44,5	0,319	137
101,6	4,0	9,63	12,3	146	3,45	28,8	38,1	293	57,6	0,319	104
101,6	5,0	11,9	15,2	177	3,42	34,9	46,7	355	69,9	0,319	84,0
101,6	6,0	14,1	18,0	207	3,39	40,7	54,9	413	81,4	0,319	70,7
101,6	6,3	14,8	18,9	215	3,38	42,3	57,3	430	84,7	0,319	67,5
114,3	2,5	6,89	8,78	137	3,95	24,0	31,3	275	48,0	0,359	145
114,3	3,0	8,23	10,5	163	3,94	28,4	37,2	325	56,9	0,359	121
114,3	4,0	10,9	13,9	211	3,90	36,9	48,7	422	73,9	0,359	91,9
114,3	5,0	13,5	17,2	257	3,87	45,0	59,8	514	89,9	0,359	74,2
114,3	6,0	16,0	20,4	300	3,83	52,5	70,4	600	105	0,359	62,4

Specified outside diameter	Specified thickness	Mass per unit length	Cross-sectional area	Second moment of area	Radius of gyration	Elastic section modulus	Plastic section modulus	Torsional inertia constant	Torsional modulus constant	Superficial area per metre length	Nominal length per tonne
D	T	M	A	I	i	W_{el}	W_{pl}	I_x	C_t	A_s	
mm	mm	kg/m	cm ²	cm ⁴	cm	cm ³	cm ³	cm ⁴	cm ³	m ² /m	m
114,3	6,3	16,8	21,4	313	3,82	54,7	73,6	625	109	0,359	59,6
114,3	8,0	21,0	26,7	379	3,77	66,4	90,6	759	133	0,359	47,7
139,7	3,0	10,1	12,9	301	4,83	43,1	56,1	602	86,2	0,439	98,9
139,7	4,0	13,4	17,1	393	4,80	56,2	73,7	786	112	0,439	74,7
139,7	5,0	16,6	21,2	481	4,77	68,8	90,8	961	138	0,439	60,2
139,7	6,0	19,8	25,2	564	4,73	80,8	107	1129	162	0,439	50,5
139,7	6,3	20,7	26,4	589	4,72	84,3	112	1177	169	0,439	48,2
139,7	8,0	26,0	33,1	720	4,66	103	139	1441	206	0,439	38,5
139,7	10,0	32,0	40,7	862	4,60	123	169	1724	247	0,439	31,3
168,3	3,0	12,2	15,6	532	5,85	63,3	82,0	1065	127	0,529	81,8
168,3	4,0	16,2	20,6	697	5,81	82,8	108	1394	166	0,529	61,7
168,3	5,0	20,1	25,7	856	5,78	102	133	1712	203	0,529	49,7
168,3	6,0	24,0	30,6	1009	5,74	120	158	2017	240	0,529	41,6
168,3	6,3	25,2	32,1	1053	5,73	125	165	2107	250	0,529	39,7
168,3	8,0	31,6	40,3	1297	5,67	154	206	2595	308	0,529	31,6
168,3	10,0	39,0	49,7	1564	5,61	186	251	3128	372	0,529	25,6
177,8	4,0	17,1	21,8	825	6,15	92,8	121	1650	186	0,559	58,3
177,8	5,0	21,3	27,1	1014	6,11	114	149	2028	228	0,559	46,9
177,8	6,0	25,4	32,4	1196	6,08	135	177	2392	269	0,559	39,3
177,8	6,3	26,6	33,9	1250	6,07	141	185	2499	281	0,559	37,5
177,8	8,0	33,5	42,7	1541	6,01	173	231	3083	347	0,559	29,9
177,8	10,0	41,4	52,7	1862	5,94	209	282	3724	419	0,559	24,2
177,8	12,0	49,1	62,5	2159	5,88	243	330	4318	486	0,559	20,4
177,8	12,5	51,0	64,9	2230	5,86	251	342	4460	502	0,559	19,6
193,7	4,0	18,7	23,8	1073	6,71	111	144	2146	222	0,609	53,4
193,7	5,0	23,3	29,6	1320	6,67	136	178	2640	273	0,609	43,0
193,7	6,0	27,8	35,4	1560	6,64	161	211	3119	322	0,609	36,0
193,7	6,3	29,1	37,1	1630	6,63	168	221	3260	337	0,609	34,3
193,7	8,0	36,6	46,7	2016	6,57	208	276	4031	416	0,609	27,3
193,7	10,0	45,3	57,7	2442	6,50	252	338	4883	504	0,609	22,1
193,7	12,0	53,8	68,5	2839	6,44	293	397	5678	586	0,609	18,6
193,7	12,5	55,9	71,2	2934	6,42	303	411	5869	606	0,609	17,9
219,1	4,0	21,2	27,0	1564	7,61	143	185	3128	286	0,688	47,1
219,1	5,0	26,4	33,6	1928	7,57	176	229	3856	352	0,688	37,9
219,1	6,0	31,5	40,2	2282	7,54	208	273	4564	417	0,688	31,7
219,1	6,3	33,1	42,1	2386	7,53	218	285	4772	436	0,688	30,2
219,1	8,0	41,6	53,1	2960	7,47	270	357	5919	540	0,688	24,0
219,1	10,0	51,6	65,7	3598	7,40	328	438	7197	657	0,688	19,4
219,1	12,0	61,3	78,1	4200	7,33	383	515	8400	767	0,688	16,3
219,1	12,5	63,7	81,1	4345	7,32	397	534	8689	793	0,688	15,7
244,5	5,0	29,5	37,6	2699	8,47	221	287	5397	441	0,768	33,9
244,5	6,0	35,3	45,0	3199	8,43	262	341	6397	523	0,768	28,3
244,5	6,3	37,0	47,1	3346	8,42	274	358	6692	547	0,768	27,0
244,5	8,0	46,7	59,4	4160	8,37	340	448	8321	681	0,768	21,4
244,5	10,0	57,8	73,7	5073	8,30	415	550	10150	830	0,768	17,3
244,5	12,0	68,8	87,7	5938	8,23	486	649	11880	972	0,768	14,5
244,5	12,5	71,5	91,1	6147	8,21	503	673	12300	1006	0,768	14,0
273,0	5,0	33,0	42,1	3781	9,48	277	359	7562	554	0,858	30,3
273,0	6,0	39,5	50,3	4487	9,44	329	428	8974	657	0,858	25,3
273,0	6,3	41,4	52,8	4696	9,43	344	448	9392	688	0,858	24,1
273,0	8,0	52,3	66,6	5852	9,37	429	562	11700	857	0,858	19,1
273,0	10,0	64,9	82,6	7154	9,31	524	692	14310	1048	0,858	15,4
273,0	12,0	77,2	98,4	8396	9,24	615	818	16790	1230	0,858	12,9
273,0	12,5	80,3	102	8697	9,22	637	849	17400	1274	0,858	12,5
323,9	5,0	39,3	50,1	6369	11,3	393	509	12740	787	1,02	25,4
323,9	6,0	47,0	59,9	7572	11,2	468	606	15150	935	1,02	21,3
323,9	6,3	49,3	62,9	7929	11,2	490	636	15860	979	1,02	20,3
323,9	8,0	62,3	79,4	9910	11,2	612	799	19820	1224	1,02	16,0
323,9	10,0	77,4	98,6	12160	11,1	751	986	24320	1501	1,02	12,9
323,9	12,0	92,3	118	14320	11,0	884	1168	28640	1768	1,02	10,8
323,9	12,5	96,0	122	14850	11,0	917	1213	29690	1833	1,02	10,4
355,6	5,0	43,2	55,1	8464	12,4	476	615	16930	952	1,12	23,1

EN 10219-2:2006 (E)

Specified outside diameter	Specified thickness	Mass per unit length	Cross-sectional area	Second moment of area	Radius of gyration	Elastic section modulus	Plastic section modulus	Torsional inertia constant	Torsional modulus constant	Superficial area per metre length	Nominal length per tonne
<i>D</i>	<i>T</i>	<i>M</i>	<i>A</i>	<i>I</i>	<i>i</i>	<i>W_{el}</i>	<i>W_{pl}</i>	<i>L_t</i>	<i>C_t</i>	<i>A_s</i>	
mm	mm	kg/m	cm ²	cm ⁴	cm	cm ³	cm ³	cm ⁴	cm ³	m ² /m	m
355,6	6,0	51,7	65,9	10070	12,4	566	733	20140	1133	1,12	19,3
355,6	6,3	54,3	69,1	10550	12,4	593	769	21090	1186	1,12	18,4
355,6	8,0	68,6	87,4	13200	12,3	742	967	26400	1485	1,12	14,6
355,6	10,0	85,2	109	16220	12,2	912	1195	32450	1825	1,12	11,7
355,6	12,0	102	130	19140	12,2	1076	1417	38280	2153	1,12	9,83
355,6	12,5	106	135	19850	12,1	1117	1472	39700	2233	1,12	9,45
355,6	16,0	134	171	24660	12,0	1387	1847	49330	2774	1,12	7,46
355,6	20,0	166	211	29800	11,9	1676	2255	59580	3351	1,12	6,04
406,4	6,0	59,2	75,5	15130	14,2	745	962	30260	1489	1,28	16,9
406,4	6,3	62,2	79,2	15850	14,1	780	1009	31700	1560	1,28	16,1
406,4	8,0	78,6	100	19870	14,1	978	1270	39750	1956	1,28	12,7
406,4	10,0	97,8	125	24480	14,0	1205	1572	48950	2409	1,28	10,2
406,4	12,0	117	149	28940	14,0	1424	1867	57870	2848	1,28	8,57
406,4	12,5	121	155	30030	13,9	1478	1940	60060	2956	1,28	8,24
406,4	16,0	154	196	37450	13,8	1843	2440	74900	3686	1,28	6,49
406,4	20,0	191	243	45430	13,7	2236	2989	90860	4472	1,28	5,25
406,4	25,0	235	300	54700	13,5	2692	3642	109400	5384	1,28	4,25
457,0	6,0	66,7	85,0	21620	15,9	946	1220	43240	1892	1,44	15,0
457,0	6,3	70,0	89,2	22650	15,9	991	1280	45310	1983	1,44	14,3
457,0	8,0	88,6	113	28450	15,9	1245	1613	56900	2490	1,44	11,3
457,0	10,0	110	140	35090	15,8	1536	1998	70180	3071	1,44	9,07
457,0	12,0	132	168	41560	15,7	1819	2377	83110	3637	1,44	7,59
457,0	12,5	137	175	43150	15,7	1888	2470	86290	3776	1,44	7,30
457,0	16,0	174	222	53960	15,6	2361	3113	107900	4723	1,44	5,75
457,0	20,0	216	275	65680	15,5	2874	3822	131400	5749	1,44	4,64
457,0	25,0	266	339	79420	15,3	3475	4671	158800	6951	1,44	3,75
457,0	30,0	316	402	92170	15,1	4034	5479	184400	8068	1,44	3,17
508,0	6,0	74,3	94,6	29810	17,7	1174	1512	59620	2347	1,60	13,5
508,0	6,3	77,9	99,3	31250	17,7	1230	1586	62490	2460	1,60	12,8
508,0	8,0	98,6	126	39280	17,7	1546	2000	78560	3093	1,60	10,1
508,0	10,0	123	156	48520	17,6	1910	2480	97040	3820	1,60	8,14
508,0	12,0	147	187	57540	17,5	2265	2953	115100	4530	1,60	6,81
508,0	12,5	153	195	59760	17,5	2353	3070	119500	4705	1,60	6,55
508,0	16,0	194	247	74910	17,4	2949	3874	149800	5898	1,60	5,15
508,0	20,0	241	307	91430	17,3	3600	4766	182900	7199	1,60	4,15
508,0	25,0	298	379	111000	17,1	4367	5837	221800	8734	1,60	3,36
508,0	30,0	354	451	129200	16,9	5086	6864	258400	10170	1,60	2,83
610,0	6,0	89,4	114	51920	21,4	1702	2189	103900	3405	1,92	11,2
610,0	6,3	93,8	119	54440	21,3	1785	2296	108900	3570	1,92	10,7
610,0	8,0	119	151	68550	21,3	2248	2899	137100	4495	1,92	8,42
610,0	10,0	148	188	84850	21,2	2782	3600	169700	5564	1,92	6,76
610,0	12,0	177	225	100800	21,1	3305	4292	201700	6611	1,92	5,65
610,0	12,5	184	235	104800	21,1	3435	4463	209000	6869	1,92	5,43
610,0	16,0	234	299	131800	21,0	4321	5647	263600	8641	1,92	4,27
610,0	20,0	291	371	161500	20,9	5295	6965	323000	10590	1,92	3,44
610,0	25,0	361	459	196900	20,7	6456	8561	393800	12910	1,92	2,77
610,0	30,0	429	547	230500	20,5	7557	10100	461000	15110	1,92	2,33
711,0	6,0	104	133	82570	24,9	2323	2982	165100	4645	2,23	9,59
711,0	6,3	109	139	86590	24,9	2436	3129	173200	4871	2,23	9,13
711,0	8,0	139	177	109200	24,9	3071	3954	218300	6141	2,23	7,21
711,0	10,0	173	220	135300	24,8	3806	4914	270600	7612	2,23	5,78
711,0	12,0	207	264	161000	24,7	4529	5864	322000	9057	2,23	4,83
711,0	12,5	215	274	167300	24,7	4707	6099	334700	9415	2,23	4,64
711,0	16,0	274	349	211000	24,6	5936	7730	422100	11870	2,23	3,65
711,0	20,0	341	434	259400	24,4	7295	9552	518700	14590	2,23	2,93
711,0	25,0	423	539	317400	24,3	8927	11770	634700	17850	2,23	2,36
711,0	30,0	504	642	372800	24,1	10490	13920	745600	21000	2,23	1,98
762,0	6,0	112	143	101800	26,7	2672	3429	20360	5345	2,39	8,94
762,0	6,3	117	150	106800	26,7	2803	3598	213600	5605	2,39	8,52
762,0	8,0	149	190	134700	26,7	3535	4548	269400	7070	2,39	6,72
762,0	10,0	185	236	167000	26,6	4384	5655	334100	8768	2,39	5,39
762,0	12,0	222	283	198900	26,5	5219	6751	397700	10440	2,39	4,51

Specified outside diameter	Specified thickness	Mass per unit length	Cross-sectional area	Second moment of area	Radius of gyration	Elastic section modulus	Plastic section modulus	Torsional inertia constant	Torsional modulus constant	Superficial area per metre length	Nominal length per tonne
D	T	M	A	I	i	W_{el}	W_{pl}	I_x	C_t	A_s	
mm	mm	kg/m	cm ²	cm ⁴	cm	cm ³	cm ³	cm ⁴	cm ³	m ² /m	m
762,0	12,5	231	294	206700	26,5	5426	7023	413500	10900	2,39	4,33
762,0	16,0	294	375	261000	26,4	6850	8906	522000	13700	2,39	3,40
762,0	20,0	366	466	321100	26,2	8427	11000	642200	16860	2,39	2,73
762,0	25,0	454	579	393500	26,1	10327	13580	786900	20650	2,39	2,20
762,0	30,0	542	690	462900	25,9	12148	16080	925700	24300	2,39	1,85
813,0	8,0	159	202	163900	28,5	4032	5184	327800	8064	2,55	6,30
813,0	10,0	198	252	203400	28,4	5003	6448	406700	10010	2,55	5,05
813,0	12,0	237	302	242200	28,3	5959	7700	484500	11930	2,55	4,22
813,0	12,5	247	314	251900	28,3	6196	8011	503700	12400	2,55	4,05
813,0	16,0	314	401	318200	28,2	7828	10170	636400	15660	2,55	3,18
813,0	20,0	391	498	392000	28,0	9641	12600	783800	19280	2,55	2,56
813,0	25,0	486	619	480900	27,9	11829	15530	961700	23660	2,55	2,06
813,0	30,0	579	738	566400	27,7	13933	18400	1133000	27870	2,55	1,73
914,0	8,0	179	228	233700	32,0	5113	6567	467300	10230	2,87	5,59
914,0	10,0	223	284	290200	32,0	6349	8172	580300	12700	2,87	4,49
914,0	12,0	267	340	345890	31,9	7569	9764	691800	15140	2,87	3,75
914,0	12,5	278	354	359700	31,9	7871	10160	719400	15740	2,87	3,60
914,0	16,0	354	451	455100	31,8	9959	12900	910300	19920	2,87	2,82
914,0	20,0	441	562	561500	31,6	12286	15990	1123000	24570	2,87	2,27
914,0	25,0	548	698	690300	31,4	15105	19760	1381000	30210	2,87	1,82
914,0	30,0	654	833	814800	31,3	17829	23450	1630000	35660	2,87	1,53
1016,0	8,0	199	253	321800	35,6	6334	8129	6436000	12670	3,19	5,03
1016,0	10,0	248	316	399900	35,6	7871	10120	799700	15740	3,19	4,03
1016,0	12,0	297	378	477000	35,5	9389	12100	954000	18780	3,19	3,37
1016,0	12,5	309	394	496100	35,5	9766	12590	992300	19530	3,19	3,23
1016,0	16,0	395	503	628500	35,4	12372	16000	1257000	24740	3,19	2,53
1016,0	20,0	491	626	776300	35,2	15282	19840	1553000	30560	3,19	2,04
1016,0	25,0	611	778	956000	35,0	18821	24560	1912000	37640	3,19	1,64
1016,0	30,0	729	929	1130000	34,9	22251	29180	2261000	44500	3,19	1,37
1067,0	10,0	261	332	463900	37,4	8693	11170	927600	17390	3,35	3,84
1067,0	12,0	312	398	553420	37,3	10373	13360	1107000	20750	3,35	3,20
1067,0	12,5	325	414	575700	37,3	10790	13900	1151000	21580	3,35	3,08
1067,0	16,0	415	528	729600	37,2	13676	17680	1459000	27350	3,35	2,41
1067,0	20,0	516	658	901800	37,0	16903	21930	1804000	33810	3,35	1,94
1067,0	25,0	642	818	1111000	36,9	20831	27150	2223000	41660	3,35	1,56
1067,0	30,0	767	977	1315000	36,7	24646	32270	2630000	49290	3,35	1,30
1168,0	10,0	286	364	609800	40,9	10443	13410	1220000	20890	3,67	3,50
1168,0	12,0	342	436	728100	40,9	12467	16040	1456000	24930	3,67	2,92
1168,0	12,5	356	454	757400	40,9	12969	16690	1515000	25940	3,67	2,81
1168,0	16,0	455	579	960800	40,7	16452	21240	1922000	32900	3,67	2,20
1168,0	20,0	566	721	1189000	40,6	20353	26360	2377000	40710	3,67	1,77
1168,0	25,0	705	898	1467000	40,4	25115	32670	2933000	50230	3,67	1,42
1219,0	10,0	298	380	694000	42,7	11387	14620	1388000	22770	3,83	3,35
1219,0	12,0	357	455	828700	42,7	13597	17480	1657000	27190	3,83	2,80
1219,0	12,5	372	474	862200	42,7	14146	18200	1724000	28290	3,83	2,69
1219,0	16,0	475	605	1094000	42,5	17951	23260	2188000	35900	3,83	2,11
1219,0	20,0	591	753	1354000	42,4	22217	28760	2708400	44440	3,83	1,69
1219,0	25,0	736	938	1672000	42,2	27430	35650	3344000	54860	3,83	1,36

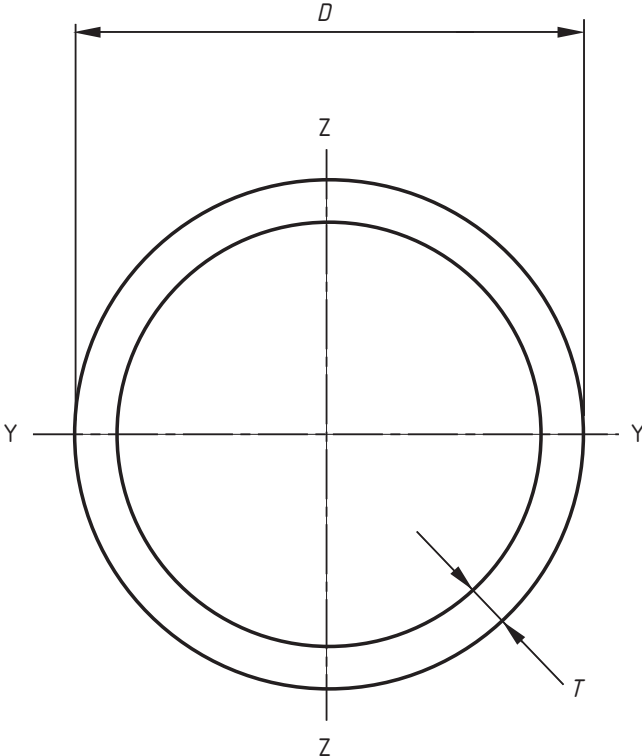

Figure C.1 — Circular hollow section

**Table C.2 — Nominal dimensions and sectional properties of a limited range of square hollow sections
(see Figure C.2)**

Specified side dimension	Specified thickness	Mass per unit length	Cross-sectional area	Second moment of area	Radius of gyration	Elastic section modulus	Plastic section modulus	Torsional inertia constant	Torsional modulus constant	Superficial area per metre length	Nominal length per tonne
B	T	M	A	I	i	W_{el}	W_{pl}	L_t	C_t	A_s	
mm	mm	kg/m	cm ²	cm ⁴	cm	cm ³	cm ³	cm ⁴	cm ³	m ² /m	m
20	2,0	1,05	1,34	0,692	0,720	0,692	0,877	1,21	1,06	0,0731	953
25	2,0	1,36	1,74	1,48	0,924	1,19	1,47	2,53	1,80	0,0931	733
25	2,5	1,64	2,09	1,69	0,899	1,35	1,71	2,97	2,07	0,0914	610
25	3,0	1,89	2,41	1,84	0,874	1,47	1,91	3,33	2,27	0,0897	529
30	2,0	1,68	2,14	2,72	1,13	1,81	2,21	4,54	2,75	0,113	596
30	2,5	2,03	2,59	3,16	1,10	2,10	2,61	5,40	3,20	0,111	492
30	3,0	2,36	3,01	3,50	1,08	2,34	2,96	6,15	3,58	0,110	423
40	2,0	2,31	2,94	6,94	1,54	3,47	4,13	11,3	5,23	0,153	434
40	2,5	2,82	3,59	8,22	1,51	4,11	4,97	13,6	6,21	0,151	355
40	3,0	3,30	4,21	9,32	1,49	4,66	5,72	15,8	7,07	0,150	303
40	4,0	4,20	5,35	11,1	1,44	5,54	7,01	19,4	8,48	0,146	238
50	2,0	2,93	3,74	14,1	1,95	5,66	6,66	22,6	8,51	0,193	341
50	2,5	3,60	4,59	16,9	1,92	6,78	8,07	27,5	10,2	0,191	278
50	3,0	4,25	5,41	19,5	1,90	7,79	9,39	32,1	11,8	0,190	236
50	4,0	5,45	6,95	23,7	1,85	9,49	11,7	40,4	14,4	0,186	183
50	5,0	6,56	8,36	27,0	1,80	10,8	13,7	47,5	16,6	0,183	152
60	2,0	3,56	4,54	25,1	2,35	8,38	9,79	39,8	12,6	0,233	281
60	2,5	4,39	5,59	30,3	2,33	10,1	11,9	48,7	15,2	0,231	228
60	3,0	5,19	6,61	35,1	2,31	11,7	14,0	57,1	17,7	0,230	193
60	4,0	6,71	8,55	43,6	2,26	14,5	17,6	72,6	22,0	0,226	149
60	5,0	8,13	10,4	50,5	2,21	16,8	20,9	86,4	25,6	0,223	123
60	6,0	9,45	12,0	56,1	2,16	18,7	23,7	98,4	28,6	0,219	106
60	6,3	9,55	12,2	54,4	2,11	18,1	23,4	100	28,8	0,213	105
70	2,5	5,17	6,59	49,4	2,74	14,1	16,5	78,5	21,2	0,271	193
70	3,0	6,13	7,81	57,5	2,71	16,4	19,4	92,4	24,7	0,270	163
70	4,0	7,97	10,1	72,1	2,67	20,6	24,8	119	31,1	0,266	126
70	5,0	9,70	12,4	84,6	2,62	24,2	29,6	142	36,7	0,263	103
70	6,0	11,3	14,4	95,2	2,57	27,2	33,8	163	41,4	0,259	88,3
70	6,3	11,5	14,7	93,8	2,53	26,8	33,8	168	42,1	0,253	86,7
80	3,0	7,07	9,01	87,8	3,12	22,0	25,8	140	33,0	0,310	141
80	4,0	9,22	11,7	111	3,07	27,8	33,1	180	41,8	0,306	108
80	5,0	11,3	14,4	131	3,03	32,9	39,7	218	49,7	0,303	88,7
80	6,0	13,2	16,8	149	2,98	37,3	45,8	252	56,6	0,299	75,7
80	6,3	13,5	17,2	149	2,94	37,1	46,1	261	57,9	0,293	74,0
80	8,0	16,4	20,8	168	2,84	42,1	53,9	307	66,6	0,286	61,1
90	3,0	8,01	10,2	127	3,53	28,3	33,0	201	42,5	0,350	125
90	4,0	10,5	13,3	162	3,48	36,0	42,6	261	54,2	0,346	95,4
90	5,0	12,8	16,4	193	3,43	42,9	51,4	316	64,7	0,343	77,9
90	6,0	15,1	19,2	220	3,39	49,0	59,5	368	74,2	0,339	66,2
90	6,3	15,5	19,7	221	3,35	49,1	60,3	382	76,2	0,333	64,6
90	8,0	18,9	24,0	255	3,25	56,6	71,3	456	88,8	0,326	53,0
100	3,0	8,96	11,4	177	3,94	35,4	41,2	279	53,2	0,390	112
100	4,0	11,7	14,9	226	3,89	45,3	53,3	362	68,1	0,386	85,2
100	5,0	14,4	18,4	271	3,84	54,2	64,6	441	81,7	0,383	69,4
100	6,0	17,0	21,6	311	3,79	62,3	75,1	514	94,1	0,379	58,9
100	6,3	17,5	22,2	314	3,76	62,8	76,4	536	97,0	0,373	57,3
100	8,0	21,4	27,2	366	3,67	73,2	91,1	645	114	0,366	46,8
100	10,0	25,6	32,6	411	3,55	82,2	105	750	130	0,357	39,1
100	12,0	28,3	36,1	408	3,36	81,6	110	794	136	0,338	35,3
100	12,5	29,1	37,0	410	3,33	82,1	111	804	137	0,336	34,4
120	3,0	10,8	13,8	312	4,76	52,1	60,2	488	78,2	0,470	92,3
120	4,0	14,2	18,1	402	4,71	67,0	78,3	637	101	0,466	70,2
120	5,0	17,5	22,4	485	4,66	80,9	95,4	778	122	0,463	57,0
120	6,0	20,7	26,4	562	4,61	93,7	112	913	141	0,459	48,2
120	6,3	21,4	27,3	572	4,58	95,3	114	955	146	0,453	46,7
120	8,0	26,4	33,6	677	4,49	113	138	1163	175	0,446	37,9
120	10,0	31,8	40,6	777	4,38	129	162	1376	203	0,437	31,4
120	12,0	35,8	45,7	806	4,20	134	174	1518	219	0,418	27,9
120	12,5	36,9	47,0	817	4,17	136	178	1551	223	0,416	27,1

EN 10219-2:2006 (E)

Specified side dimension	Specified thickness	Mass per unit length	Cross-sectional area	Second moment of area	Radius of gyration	Elastic section modulus	Plastic section modulus	Torsional inertia constant	Torsional modulus constant	Superficial area per metre length	Nominal length per tonne
<i>B</i>	<i>T</i>	<i>M</i>	<i>A</i>	<i>I</i>	<i>i</i>	<i>W_{el}</i>	<i>W_{pl}</i>	<i>L_t</i>	<i>C_t</i>	<i>A_s</i>	
mm	mm	kg/m	cm ²	cm ⁴	cm	cm ³	cm ³	cm ⁴	cm ³	m ² /m	m
140	4,0	16,8	21,3	652	5,52	93,1	108	1023	140	0,546	59,7
140	5,0	20,7	26,4	791	5,48	113	132	1256	170	0,543	48,3
140	6,0	24,5	31,2	920	5,43	131	155	1479	198	0,539	40,8
140	6,3	25,4	32,3	941	5,39	134	160	1550	205	0,533	39,4
140	8,0	31,4	40,0	1127	5,30	161	194	1901	248	0,526	31,8
140	10,0	38,1	48,6	1312	5,20	187	230	2274	291	0,517	26,2
140	12,0	43,4	55,3	1398	5,03	200	253	2567	322	0,498	23,1
140	12,5	44,8	57,0	1425	5,00	204	259	2634	329	0,496	22,3
150	4,0	18,0	22,9	808	5,93	108	125	1265	162	0,586	55,5
150	5,0	22,3	28,4	982	5,89	131	153	1554	197	0,583	44,9
150	6,0	26,4	33,6	1146	5,84	153	180	1833	230	0,579	37,9
150	6,3	27,4	34,8	1174	5,80	156	185	1922	239	0,573	36,6
150	8,0	33,9	43,2	1412	5,71	188	226	2364	289	0,566	29,5
150	10,0	41,3	52,6	1653	5,61	220	269	2839	341	0,557	24,2
150	12,0	47,1	60,1	1780	5,44	237	298	3231	380	0,538	21,2
150	12,5	48,7	62,0	1817	5,41	242	306	3321	389	0,536	20,5
150	16,0	58,7	74,8	2009	5,18	268	351	3830	440	0,518	17,0
160	4,0	19,3	24,5	987	6,34	123	143	1541	185	0,626	51,9
160	5,0	23,8	30,4	1202	6,29	150	175	1896	226	0,623	42,0
160	6,0	28,3	36,0	1405	6,25	176	206	2239	264	0,619	35,4
160	6,3	29,3	37,4	1442	6,21	180	213	2349	275	0,613	34,1
160	8,0	36,5	46,4	1741	6,12	218	260	2897	334	0,606	27,4
160	10,0	44,4	56,6	2048	6,02	256	311	3490	395	0,597	22,5
160	12,0	50,9	64,9	2224	5,86	278	346	3997	443	0,578	19,6
160	12,5	52,6	67,0	2275	5,83	284	356	4114	455	0,576	19,0
160	16,0	63,7	81,2	2546	5,60	318	413	4799	520	0,558	15,7
180	4,0	21,8	27,7	1422	7,16	158	182	2210	237	0,706	45,9
180	5,0	27,0	34,4	1737	7,11	193	224	2724	290	0,703	37,1
180	6,0	32,1	40,8	2037	7,06	226	264	3223	340	0,699	31,2
180	6,3	33,3	42,4	2096	7,03	233	273	3383	354	0,693	30,0
180	8,0	41,5	52,8	2546	6,94	283	336	4189	432	0,686	24,1
180	10,0	50,7	64,6	3017	6,84	335	404	5074	515	0,677	19,7
180	12,0	58,5	74,5	3322	6,68	369	454	5865	584	0,658	17,1
180	12,5	60,5	77,0	3406	6,65	378	467	6050	600	0,656	16,5
180	16,0	73,8	94,0	3887	6,43	432	550	7178	698	0,638	13,6
200	4,0	24,3	30,9	1968	7,97	197	226	3049	295	0,786	41,2
200	5,0	30,1	38,4	2410	7,93	241	279	3763	362	0,783	33,2
200	6,0	35,8	45,6	2833	7,88	283	330	4459	426	0,779	27,9
200	6,3	37,2	47,4	2922	7,85	292	341	4682	444	0,773	26,8
200	8,0	46,5	59,2	3566	7,76	357	421	5815	544	0,766	21,5
200	10,0	57,0	72,6	4251	7,65	425	508	7072	651	0,757	17,6
200	12,0	66,0	84,1	4730	7,50	473	576	8230	743	0,738	15,2
200	12,5	68,3	87,0	4859	7,47	486	594	8502	765	0,736	14,6
200	16,0	83,8	107	5625	7,26	562	706	10210	901	0,718	11,9
220	5,0	33,2	42,4	3238	8,74	294	340	5038	442	0,863	30,1
220	6,0	39,6	50,4	3813	8,70	347	402	5976	521	0,859	25,3
220	6,3	41,2	52,5	3940	8,66	358	417	6277	543	0,853	24,3
220	8,0	51,5	65,6	4828	8,58	439	516	7815	668	0,846	19,4
220	10,0	63,2	80,6	5782	8,47	526	625	9533	804	0,837	15,8
220	12,0	73,5	93,7	6487	8,32	590	712	11150	922	0,818	13,6
220	12,5	76,2	97,0	6674	8,29	607	735	11530	951	0,816	13,1
220	16,0	93,9	120	7812	8,08	710	881	13970	1129	0,798	10,7
250	5,0	38,0	48,4	4805	9,97	384	442	7443	577	0,983	26,3
250	6,0	45,2	57,6	5672	9,92	454	524	8843	681	0,979	22,1
250	6,3	47,1	60,0	5873	9,89	470	544	9290	711	0,973	21,2
250	8,0	59,1	75,2	7229	9,80	578	676	11600	878	0,966	16,9
250	10,0	72,7	92,6	8707	9,70	697	822	14200	1062	0,957	13,8
250	12,0	84,8	108	9859	9,55	789	944	16690	1226	0,938	11,8
250	12,5	88,0	112	10160	9,52	813	975	17280	1266	0,936	11,4
250	16,0	109	139	12050	9,32	964	1180	21150	1520	0,918	9,18
260	6,0	47,1	60,0	6405	10,3	493	569	9970	739	1,02	21,2
260	6,3	49,1	62,6	6635	10,3	510	591	10480	772	1,01	20,4

Specified side dimension	Specified thickness	Mass per unit length	Cross-sectional area	Second moment of area	Radius of gyration	Elastic section modulus	Plastic section modulus	Torsional inertia constant	Torsional modulus constant	Superficial area per metre length	Nominal length per tonne
B	T	M	A	I	i	W_{el}	W_{pl}	I_t	C_t	A_s	
mm	mm	kg/m	cm ²	cm ⁴	cm	cm ³	cm ³	cm ⁴	cm ³	m ² /m	m
260	8,0	61,6	78,4	8178	10,2	629	734	13090	955	1,01	16,2
260	10,0	75,8	96,6	9865	10,1	759	894	16040	1156	0,997	13,2
260	12,0	88,6	113	11200	9,96	862	1028	18880	1337	0,978	11,3
260	12,5	91,9	117	11550	9,93	888	1063	19550	1381	0,976	10,9
260	16,0	114	145	13740	9,73	1057	1289	23990	1663	0,958	8,77
300	6,0	54,7	69,6	9964	12,0	664	764	15430	997	1,18	18,3
300	6,3	57,0	72,6	10340	11,9	689	795	16220	1042	1,17	17,5
300	8,0	71,6	91,2	12800	11,8	853	991	20310	1293	1,17	14,0
300	10,0	88,4	113	15520	11,7	1035	1211	24970	1572	1,16	11,3
300	12,0	104	132	17770	11,6	1184	1402	29510	1829	1,14	9,65
300	12,5	108	137	18350	11,6	1223	1451	30600	1892	1,14	9,30
300	16,0	134	171	22080	11,4	1472	1774	37840	2299	1,12	7,46
350	8,0	84,2	107	20680	13,9	1182	1366	32560	1787	1,37	11,9
350	10,0	104	133	25190	13,8	1439	1675	40130	2182	1,36	9,61
350	12,0	123	156	29050	13,6	1660	1949	47600	2552	1,34	8,16
350	12,5	127	162	30050	13,6	1717	2020	49390	2642	1,34	7,86
350	16,0	159	203	36510	13,4	2086	2488	61480	3238	1,32	6,28
400	10,0	120	153	38220	15,8	1911	2214	60430	2892	1,56	8,35
400	12,0	141	180	44320	15,7	2216	2587	71840	3395	1,54	7,07
400	12,5	147	187	45880	15,7	2294	2683	74600	3518	1,54	6,81
400	16,0	184	235	56150	15,5	2808	3322	93280	4336	1,52	5,43

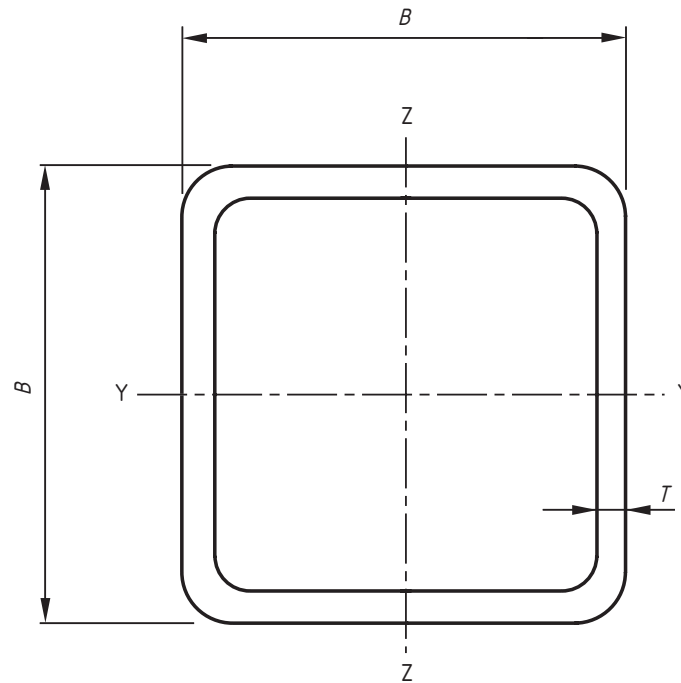

Figure C.2 — Square hollow section

Table C.3 — Nominal dimensions and sectional properties of a limited range of rectangular hollow sections (see Figure C.3)

Specified side dimensions		Specified thickness	Mass per unit length	Cross sectional area	Second moment of area		Radius of gyration		Elastic section modulus		Plastic section modulus		Torsional inertia constant	Superficial area per metre length		Nominal length per tonne
<i>B</i>	<i>H</i>				<i>T</i>	<i>M</i>	<i>A</i>	<i>I_{yy}</i>	<i>I_{zz}</i>	<i>i_{yy}</i>	<i>i_{zz}</i>	<i>W_{el_{yy}}</i>		<i>W_{el_{zz}}</i>	<i>W_{pl_{yy}}</i>	
mm	mm	mm	kg/m	cm ²	cm ⁴	cm ⁴	cm	cm	cm ³	cm ³	cm ³	cm ³	cm ⁴	cm ³	m ² /m	m
40	20	2,0	1,68	2,14	4,05	1,34	1,38	0,793	2,02	1,34	2,61	1,60	3,45	2,36	0,113	596
40	20	2,5	2,03	2,59	4,69	1,54	1,35	0,770	2,35	1,54	3,09	1,88	4,06	2,72	0,111	492
40	20	3,0	2,36	3,01	5,21	1,68	1,32	0,748	2,60	1,68	3,50	2,12	4,57	3,00	0,110	423
50	30	2,0	2,31	2,94	9,54	4,29	1,80	1,21	3,81	2,86	4,74	3,33	9,77	4,84	0,153	434
50	30	2,5	2,82	3,59	11,3	5,05	1,77	1,19	4,52	3,37	5,70	3,98	11,7	5,72	0,151	355
50	30	3,0	3,30	4,21	12,8	5,70	1,75	1,16	5,13	3,80	6,57	4,58	13,5	6,49	0,150	303
50	30	4,0	4,20	5,35	15,3	6,69	1,69	1,12	6,10	4,46	8,05	5,58	16,5	7,71	0,146	238
60	40	2,0	2,93	3,74	18,4	9,83	2,22	1,62	6,14	4,92	7,47	5,65	20,7	8,12	0,193	341
60	40	2,5	3,60	4,59	22,1	11,7	2,19	1,60	7,36	5,87	9,06	6,84	25,1	9,72	0,191	278
60	40	3,0	4,25	5,41	25,4	13,4	2,17	1,58	8,46	6,72	10,5	7,94	29,3	11,2	0,190	236
60	40	4,0	5,45	6,95	31,0	16,3	2,11	1,53	10,3	8,14	13,2	9,89	36,7	13,7	0,186	183
60	40	5,0	6,56	8,36	35,3	18,4	2,06	1,48	11,8	9,21	15,4	11,5	42,8	15,6	0,183	152
70	50	2,0	3,56	4,54	31,5	18,8	2,63	2,03	8,99	7,50	10,8	8,58	37,5	12,2	0,233	281
70	50	2,5	4,39	5,59	38,0	22,6	2,61	2,01	10,9	9,04	13,2	10,4	45,8	14,7	0,231	228
70	50	3,0	5,19	6,61	44,1	26,1	2,58	1,99	12,6	10,4	15,4	12,2	53,6	17,1	0,230	193
70	50	4,0	6,71	8,55	54,7	32,2	2,53	1,94	15,6	12,9	19,5	15,4	68,1	21,2	0,226	149
70	50	5,0	8,13	10,4	63,5	37,2	2,48	1,90	18,1	14,9	23,1	18,2	80,8	24,6	0,223	123
80	40	2,0	3,56	4,54	37,4	12,7	2,87	1,67	9,34	6,36	11,6	7,17	30,9	11,0	0,233	281
80	40	2,5	4,39	5,59	45,1	15,3	2,84	1,65	11,3	7,63	14,1	8,72	37,6	13,2	0,231	228
80	40	3,0	5,19	6,61	52,3	17,6	2,81	1,63	13,1	8,78	16,5	10,2	43,9	15,3	0,230	193
80	40	4,0	6,71	8,55	64,8	21,5	2,75	1,59	16,2	10,7	20,9	12,8	55,2	18,8	0,226	149
80	40	5,0	8,13	10,4	75,1	24,6	2,69	1,54	18,8	12,3	24,7	15,0	65,0	21,7	0,223	123
80	60	2,0	4,19	5,34	49,5	31,9	3,05	2,44	12,4	10,6	14,7	12,1	61,2	17,1	0,273	239
80	60	2,5	5,17	6,59	60,1	38,6	3,02	2,42	15,0	12,9	18,0	14,8	75,1	20,7	0,271	193
80	60	3,0	6,13	7,81	70,0	44,9	3,00	2,40	17,5	15,0	21,2	17,4	88,3	24,1	0,270	163
80	60	4,0	7,97	10,1	87,9	56,1	2,94	2,35	22,0	18,7	27,0	22,1	113	30,3	0,266	126
80	60	5,0	9,70	12,4	103	65,7	2,89	2,31	25,8	21,9	32,2	26,4	136	35,7	0,263	103
90	50	2,0	4,19	5,34	57,9	23,4	3,29	2,09	12,9	9,35	15,7	10,5	53,4	15,9	0,273	239
90	50	2,5	5,17	6,59	70,3	28,2	3,27	2,07	15,6	11,3	19,3	12,8	65,3	19,2	0,271	193
90	50	3,0	6,13	7,81	81,9	32,7	3,24	2,05	18,2	13,1	22,6	15,0	76,7	22,4	0,270	163
90	50	4,0	7,97	10,1	103	40,7	3,18	2,00	22,8	16,3	28,8	19,1	97,7	28,0	0,266	126
90	50	5,0	9,70	12,4	121	47,4	3,12	1,96	26,8	18,9	34,4	22,7	116	32,7	0,263	103
100	40	2,5	5,17	6,59	79,3	18,8	3,47	1,69	15,9	9,39	20,2	10,6	50,5	16,8	0,271	193
100	40	3,0	6,13	7,81	92,3	21,7	3,44	1,67	18,5	10,8	23,7	12,4	59,0	19,4	0,270	163
100	40	4,0	7,97	10,1	116	26,7	3,38	1,62	23,1	13,3	30,3	15,7	74,5	24,0	0,266	126
100	40	5,0	9,70	12,4	136	30,8	3,31	1,58	27,1	15,4	36,1	18,5	87,9	27,9	0,263	103
100	50	2,5	5,56	7,09	91,2	31,1	3,59	2,09	18,2	12,4	22,7	14,0	75,4	21,5	0,291	180
100	50	3,0	6,60	8,41	106	36,1	3,56	2,07	21,3	14,4	26,7	16,4	88,6	25,0	0,290	152
100	50	4,0	8,59	10,9	134	44,9	3,50	2,03	26,8	18,0	34,1	20,9	113	31,3	0,286	116
100	50	5,0	10,5	13,4	158	52,5	3,44	1,98	31,6	21,0	40,8	25,0	135	36,8	0,283	95,4
100	50	6,0	12,3	15,6	179	58,7	3,38	1,94	35,8	23,5	46,9	28,5	154	41,4	0,279	81,5
100	50	6,3	12,5	15,9	176	58,2	3,32	1,91	35,1	23,3	46,9	28,6	158	42,1	0,273	79,9
100	60	2,5	5,96	7,59	103	46,9	3,69	2,49	20,6	15,6	25,1	17,7	103	26,2	0,311	168
100	60	3,0	7,07	9,01	121	54,6	3,66	2,46	24,1	18,2	29,6	20,8	122	30,6	0,310	141
100	60	4,0	9,22	11,7	153	68,7	3,60	2,42	30,5	22,9	37,9	26,6	156	38,7	0,306	108
100	60	5,0	11,3	14,4	181	80,8	3,55	2,37	36,2	26,9	45,6	31,9	188	45,8	0,303	88,7
100	60	6,0	13,2	16,8	205	91,2	3,49	2,33	41,1	30,4	52,5	36,6	216	51,9	0,299	75,7
100	60	6,3	13,5	17,2	203	90,9	3,44	2,30	40,7	30,3	52,8	36,9	223	53,0	0,293	74,0
100	80	2,5	6,74	8,59	127	90,2	3,84	3,24	25,4	22,5	30,0	25,8	166	35,7	0,351	148
100	80	3,0	8,01	10,2	149	106	3,82	3,22	29,8	26,4	35,4	30,4	196	41,9	0,350	125
100	80	4,0	10,5	13,3	189	134	3,77	3,17	37,9	33,5	45,6	39,2	254	53,4	0,346	95,4
100	80	5,0	12,8	16,4	226	160	3,72	3,12	45,2	39,9	55,1	47,2	308	63,7	0,343	77,9

Specified side dimensions		Specified thickness	Mass per unit length	Cross sectional area	Second moment of area		Radius of gyration		Elastic section modulus		Plastic section modulus		Torsional inertia constant	Superficial area per metre length		Nominal length per tonne
B × H		T	M	A	I _{yy}	I _{zz}	i _{yy}	i _{zz}	W _{el yy}	W _{el zz}	W _{pl yy}	W _{pl zz}	L _t	C _t	A _s	
mm	mm	mm	kg/m	cm ²	cm ⁴	cm ⁴	cm	cm	cm ³	cm ³	cm ³	cm ³	cm ⁴	cm ³	m ² /m	m
100	80	6,0	15,1	19,2	258	182	3,67	3,08	51,7	45,5	63,8	54,7	357	73,0	0,339	66,2
100	80	6,3	15,5	19,7	259	183	3,62	3,04	51,8	45,7	64,6	55,4	371	75,0	0,333	64,6
120	60	2,5	6,74	8,59	161	55,2	4,33	2,53	26,9	18,4	33,2	20,6	133	31,7	0,351	148
120	60	3,0	8,01	10,2	189	64,4	4,30	2,51	31,5	21,5	39,2	24,2	156	37,1	0,350	125
120	60	4,0	10,5	13,3	241	81,2	4,25	2,47	40,1	27,1	50,5	31,1	201	47,0	0,346	95,4
120	60	5,0	12,8	16,4	287	96,0	4,19	2,42	47,8	32,0	60,9	37,4	242	55,8	0,343	77,9
120	60	6,0	15,1	19,2	328	109	4,13	2,38	54,7	36,3	70,6	43,1	280	63,6	0,339	66,2
120	60	6,3	15,5	19,7	327	109	4,07	2,35	54,5	36,4	71,2	43,7	289	65,1	0,333	64,6
120	60	8,0	18,9	24,0	375	124	3,95	2,27	62,6	41,3	84,1	51,3	340	75,0	0,326	53,0
120	80	3,0	8,96	11,4	230	123	4,49	3,29	38,4	30,9	46,2	35,0	255	50,8	0,390	112
120	80	4,0	11,7	14,9	295	157	4,44	3,24	49,1	39,3	59,8	45,2	331	64,9	0,386	85,2
120	80	5,0	14,4	18,4	353	188	4,39	3,20	58,9	46,9	72,4	54,7	402	77,8	0,383	69,4
120	80	6,0	17,0	21,6	406	215	4,33	3,15	67,7	53,8	84,3	63,5	469	89,4	0,379	58,9
120	80	6,3	17,5	22,2	408	217	4,28	3,12	68,1	54,3	85,6	64,7	488	92,1	0,373	57,3
120	80	8,0	21,4	27,2	476	252	4,18	3,04	79,3	62,9	102	76,9	584	108	0,366	46,8
140	80	4,0	13,0	16,5	430	180	5,10	3,30	61,4	45,1	75,5	51,3	412	76,5	0,426	77,0
140	80	5,0	16,0	20,4	517	216	5,04	3,26	73,9	54,0	91,8	62,2	501	91,8	0,423	62,6
140	80	6,0	18,9	24,0	597	248	4,98	3,21	85,3	62,0	107	72,4	584	106	0,419	53,0
140	80	6,3	19,4	24,8	603	251	4,93	3,19	86,1	62,9	109	74,0	609	109	0,413	51,4
140	80	8,0	23,9	30,4	708	293	4,82	3,10	101	73,3	131	88,4	731	129	0,406	41,8
150	100	4,0	14,9	18,9	595	319	5,60	4,10	79,3	63,7	95,7	72,5	662	105	0,486	67,2
150	100	5,0	18,3	23,4	719	384	5,55	4,05	95,9	76,8	117	88,3	809	127	0,483	54,5
150	100	6,0	21,7	27,6	835	444	5,50	4,01	111	88,8	137	103	948	147	0,479	46,1
150	100	6,3	22,4	28,5	848	453	5,45	3,98	113	90,5	140	106	992	152	0,473	44,6
150	100	8,0	27,7	35,2	1008	536	5,35	3,90	134	107	169	128	1206	182	0,466	36,1
150	100	10,0	33,4	42,6	1162	614	5,22	3,80	155	123	199	150	1426	211	0,457	29,9
150	100	12,0	37,7	48,1	1207	642	5,01	3,65	161	128	215	163	1573	229	0,438	26,5
150	100	12,5	38,9	49,5	1225	651	4,97	3,63	163	130	220	166	1606	233	0,436	25,7
160	80	4,0	14,2	18,1	598	204	5,74	3,35	74,7	50,9	92,9	57,4	494	88,0	0,466	70,2
160	80	5,0	17,5	22,4	722	244	5,68	3,30	90,2	61,0	113	69,7	601	106	0,463	57,0
160	80	6,0	20,7	26,4	836	281	5,62	3,26	105	70,2	132	81,3	702	122	0,459	48,2
160	80	6,3	21,4	27,3	846	286	5,57	3,24	106	71,4	135	83,3	732	126	0,453	46,7
160	80	8,0	26,4	33,6	1001	335	5,46	3,16	125	83,7	163	100	882	150	0,446	37,9
160	80	10,0	31,8	40,6	1146	380	5,32	3,06	143	95,0	191	117	1031	172	0,437	31,4
160	80	12,0	35,8	45,7	1171	391	5,06	2,93	146	97,8	204	125	1111	183	0,418	27,9
160	80	12,5	36,9	47,0	1185	396	5,02	2,90	148	98,9	208	127	1129	185	0,416	27,1
180	100	4,0	16,8	21,3	926	374	6,59	4,18	103	74,8	126	84,0	854	127	0,546	59,7
180	100	5,0	20,7	26,4	1124	452	6,53	4,14	125	90,4	154	103	1045	154	0,543	48,3
180	100	6,0	24,5	31,2	1310	524	6,48	4,10	146	105	181	120	1227	179	0,539	40,8
180	100	6,3	25,4	32,3	1335	536	6,43	4,07	148	107	186	124	1283	185	0,533	39,4
180	100	8,0	31,4	40,0	1598	637	6,32	3,99	178	127	226	150	1565	222	0,526	31,8
180	100	10,0	38,1	48,6	1859	736	6,19	3,89	207	147	268	177	1859	260	0,517	26,2
180	100	12,0	43,4	55,3	1965	782	5,96	3,76	218	156	292	194	2073	285	0,498	23,1
180	100	12,5	44,8	57,0	2001	796	5,92	3,74	222	159	300	199	2122	290	0,496	22,3
200	100	4,0	18,0	22,9	1200	411	7,23	4,23	120	82,2	148	91,7	985	142	0,586	55,5
200	100	5,0	22,3	28,4	1459	497	7,17	4,19	146	99,4	181	112	1206	172	0,583	44,9
200	100	6,0	26,4	33,6	1703	577	7,12	4,14	170	115	213	132	1417	200	0,579	37,9
200	100	6,3	27,4	34,8	1739	591	7,06	4,12	174	118	219	135	1483	208	0,573	36,6
200	100	8,0	33,9	43,2	2091	705	6,95	4,04	209	141	267	165	1811	250	0,566	29,5
200	100	10,0	41,3	52,6	2444	818	6,82	3,94	244	164	318	195	2154	292	0,557	24,2
200	100	12,0	47,1	60,1	2607	876	6,59	3,82	261	175	350	215	2414	322	0,538	21,2
200	100	12,5	48,7	62,0	2659	892	6,55	3,79	266	178	359	221	2474	329	0,536	20,5
200	120	4,0	19,3	24,5	1353	618	7,43	5,02	135	103	164	115	1345	172	0,626	51,9
200	120	5,0	23,8	30,4	1649	750	7,37	4,97	165	125	201	141	1652	210	0,623	42,0
200	120	6,0	28,3	36,0	1929	874	7,32	4,93	193	146	237	166	1947	245	0,619	35,4
200	120	6,3	29,3	37,4	1976	898	7,27	4,90	198	150	244	172	2040	255	0,613	34,1

EN 10219-2:2006 (E)

Specified side dimensions		Specified thickness	Mass per unit length	Cross sectional area	Second moment of area		Radius of gyration		Elastic section modulus		Plastic section modulus		Torsional inertia constant	Superficial area per metre length		Nominal length per tonne
B × H		T	M	A	I _{yy}	I _{zz}	i _{yy}	i _{zz}	W _{el yy}	W _{el zz}	W _{pl yy}	W _{pl zz}	L _t	C _t	A _s	
mm	mm	mm	kg/m	cm ²	cm ⁴	cm ⁴	cm	cm	cm ³	cm ³	cm ³	cm ³	cm ⁴	cm ³	m ² /m	m
200	120	8,0	36,5	46,4	2386	1079	7,17	4,82	239	180	298	209	2507	308	0,606	27,4
200	120	10,0	44,4	56,6	2806	1262	7,04	4,72	281	210	356	250	3007	364	0,597	22,5
200	120	12,0	50,9	64,9	3031	1368	6,84	4,59	303	228	395	278	3419	406	0,578	19,6
200	120	12,5	52,6	67,0	3099	1397	6,80	4,57	310	233	406	285	3514	416	0,576	19,0
250	150	5,0	30,1	38,4	3304	1508	9,28	6,27	264	201	320	225	3285	337	0,783	33,2
250	150	6,0	35,8	45,6	3886	1768	9,23	6,23	311	236	378	266	3886	396	0,779	27,9
250	150	6,3	37,2	47,4	4001	1825	9,18	6,20	320	243	391	276	4078	412	0,773	26,8
250	150	8,0	46,5	59,2	4886	2219	9,08	6,12	391	296	482	340	5050	504	0,766	21,5
250	150	10,0	57,0	72,6	5825	2634	8,96	6,02	466	351	582	409	6121	602	0,757	17,6
250	150	12,0	66,0	84,1	6458	2925	8,77	5,90	517	390	658	463	7088	684	0,738	15,2
250	150	12,5	68,3	87,0	6633	3002	8,73	5,87	531	400	678	477	7315	704	0,736	14,6
250	150	16,0	83,8	106,8	7660	3453	8,47	5,69	613	460	805	566	8713	823	0,718	11,9
260	180	5,0	33,2	42,4	4121	2350	9,86	7,45	317	261	377	294	4695	426	0,863	30,1
260	180	6,3	41,2	52,5	5013	2856	9,77	7,38	386	317	463	361	5844	523	0,853	24,3
260	180	8,0	51,5	65,6	6145	3493	9,68	7,29	473	388	573	446	7267	642	0,846	19,4
260	180	10,0	63,2	80,6	7363	4174	9,56	7,20	566	464	694	540	8850	772	0,837	15,8
260	180	12,0	73,5	93,7	8245	4679	9,38	7,07	634	520	790	615	10330	884	0,818	13,6
260	180	12,5	76,2	97,0	8482	4812	9,35	7,04	652	535	815	635	10680	911	0,816	13,1
260	180	16,0	93,9	120	9923	5614	9,11	6,85	763	624	977	759	12890	1079	0,798	10,7
300	100	6,0	35,8	45,6	4777	842	10,2	4,30	318	168	411	188	2403	306	0,779	27,9
300	100	6,3	37,2	47,4	4907	868	10,2	4,28	327	174	425	194	2515	318	0,773	26,8
300	100	8,0	46,5	59,2	5978	1045	10,0	4,20	399	209	523	238	3080	385	0,766	21,5
300	100	10,0	57,0	72,6	7106	1224	9,90	4,11	474	245	631	285	3681	455	0,757	17,6
300	100	12,0	66,0	84,1	7808	1343	9,64	4,00	521	269	710	321	4177	508	0,738	15,2
300	100	12,5	68,3	87,0	8010	1374	9,59	3,97	534	275	732	330	4292	521	0,736	14,6
300	100	16,0	83,8	107	9157	1543	9,26	3,80	610	309	865	386	4939	592	0,718	11,9
300	150	6,0	40,5	51,6	6074	2080	10,8	6,35	405	277	500	309	4988	479	0,879	24,7
300	150	6,3	42,2	53,7	6266	2150	10,8	6,32	418	287	517	321	5234	499	0,873	23,7
300	150	8,0	52,8	67,2	7684	2623	10,7	6,25	512	350	640	396	6491	612	0,866	18,9
300	150	10,0	64,8	82,6	9209	3125	10,6	6,15	614	417	776	479	7879	733	0,857	15,4
300	150	12,0	75,4	96,1	10300	3498	10,4	6,03	687	466	883	546	9153	837	0,838	13,3
300	150	12,5	78,1	99,5	10590	3595	10,3	6,01	706	479	912	563	9452	862	0,836	12,8
300	150	16,0	96,4	123	12390	4174	10,0	5,83	826	557	1092	673	11330	1015	0,818	10,4
300	200	6,0	45,2	57,6	7370	3962	11,3	8,29	491	396	588	446	8115	651	0,979	22,1
300	200	6,3	47,1	60,0	7624	4104	11,3	8,27	508	410	610	463	8524	680	0,973	21,2
300	200	8,0	59,1	75,2	9389	5042	11,2	8,19	626	504	757	574	10630	838	0,966	16,9
300	200	10,0	72,7	92,6	11310	6058	11,1	8,09	754	606	921	698	12990	1012	0,957	13,8
300	200	12,0	84,8	108	12790	6854	10,9	7,96	853	685	1056	801	15240	1167	0,938	11,8
300	200	12,5	88,0	112	13180	7060	10,8	7,94	879	706	1091	828	15770	1204	0,936	11,4
300	200	16,0	109	139	15620	8340	10,6	7,75	1041	834	1319	1000	19220	1442	0,918	9,18
350	250	6,0	54,7	69,6	12460	7458	13,4	10,3	712	597	843	671	14550	967	1,18	18,3
350	250	6,3	57,0	72,6	12920	7744	13,3	10,3	738	620	876	698	15290	1010	1,17	17,5
350	250	8,0	71,6	91,2	16000	9573	13,2	10,2	914	766	1092	869	19140	1253	1,17	14,0
350	250	10,0	88,4	113	19410	11590	13,1	10,1	1109	927	1335	1062	23500	1522	1,16	11,3
350	250	12,0	104	132	22200	13260	13,0	10,0	1268	1061	1544	1229	27750	1770	1,14	9,65
350	250	12,5	108	137	22920	13690	12,9	9,99	1310	1095	1598	1272	28770	1830	1,14	9,30
350	250	16,0	134	171	27580	16430	12,7	9,81	1576	1315	1954	1554	35500	2220	1,12	7,46
400	200	8,0	71,6	91,2	18970	6517	14,4	8,45	949	652	1173	728	15820	1133	1,17	14,0
400	200	12,5	108	137	27100	9260	14,1	8,22	1355	926	1714	1062	23600	1644	1,14	9,30
400	200	16,0	134	171	32550	11060	13,8	8,05	1627	1106	2093	1294	28930	1984	1,12	7,46
400	300	8,0	84,2	107	25120	16210	15,3	12,3	1256	1081	1487	1224	31180	1747	1,37	11,9
400	300	10,0	104	133	30610	19730	15,2	12,2	1530	1315	1824	1501	38410	2132	1,36	9,61
400	300	12,0	123	156	35280	22750	15,0	12,1	1764	1516	2122	1747	45530	2492	1,34	8,16
400	300	12,5	127	162	36490	23520	15,0	12,0	1824	1568	2198	1810	47240	2580	1,34	7,86
400	300	16,0	159	203	44350	28540	14,8	11,9	2218	1902	2708	2228	58730	3159	1,32	6,28

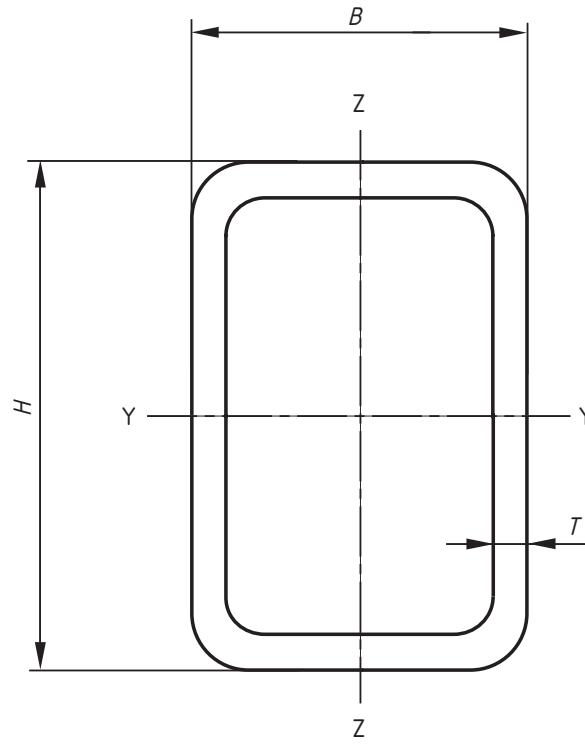

Figure C.3 — Rectangular hollow section

Bibliography

ENV 1993-1-6, *Eurocode 3: Design of steel structures - Part 1-6: General rules - Supplementary rules for the shell structures*

ENV 1993-5, *Eurocode 3: Design of steel structures - Part 5: Piling*