



Steels for General Structural Purposes
Quality Standard

DIN
17 100

Allgemeine Baustähle; Gütenorm

For connection with the Standard ISO 630 issued by the International Organization for Standardization (ISO) and Euronorm 25 issued by the European Community for Coal and Steel, see Explanations.

Druckfehler S.4 // mit Nachdruck bereits korrigiert

Contents

	Page		Page
1	2	9	10
2	2	9.1	10
3	2	9.2	10
4	2	9.3	10
5	2	9.3.1	10
6	6	9.3.2	11
7	6	9.3.3	11
8	8	9.4	11
8.1	8	9.4.1	11
8.2	8	9.4.2	11
8.3	8	9.4.3	11
8.4	8	9.5	14
8.4.1	8	9.6	15
8.4.2	9	10	15
8.4.3	9	11	15
8.4.4	10		
8.5	10		

Continued on pages 2 to 16
Explanations on pages 17 to 19

Zementanlagen- und Maschinenbau GmbH Dessau

140

Reproduced by permission of DIN Deutsches Institut für Normung e.V.
 The wording of the latest edition of the standard obtained from Beuth Verlag GmbH, Burggrafenstr. 6, 1000 Berlin 30, is applicable for its use in production, even in parts, only with the explicit permission of the DIN Deutsches Institut für Normung e.V., Berlin

Translation
 Technical Help to Exporters
 Service of BSI

No guarantee can be given in respect of this translation.
 In all cases the latest German-language version of this Standard shall be taken as authoritative

1 Scope

1.1 This Standard applies to steel sections (including wide flange beams), steel bars, wire rod, flat products (strip, plate, wide flats) seamless and welded, square and rectangular hollow sections, forgings and semi-finished products in the general structural steels named in Tables 1 to 3 which are delivered in the hot formed or normalized condition after production.

1.2 Products from steels according to this Standard are for use in welded (but see Section 8.4.2), riveted and screwed structural components. They are not intended for heat treatment – apart from stress-relieving heat treatment and normalizing.

1.3 This Standard does not cover the following products from steels for general structural purposes:

Seamless and welded tubes and precision steel tubes (see DIN 1626 Part 1 to Part 4, DIN 1629 Part 1 to Part 4, DIN 2391 Part 2, DIN 2393 Part 2, DIN 2394, DIN 2395 Part 2, DIN 2395 Part 3),

Steel castings (see DIN 1681),

Cold rolled flat products without coating (see DIN 1623 Part 2, new version in preparation),

Flat steel products with coatings (DIN Standards in preparation),

Bright finished steel (see DIN 1652),

Cold rolled sections (see DIN 17 118),

Cold finished steel hollow sections (DIN Standards in preparation).

For notes on Standards and standard-type publications for steels with adjacent fields of application see the end of this Standard.

2 Other relevant Standards and documents

DIN 1599	(at present in draft form) Marking of steels
DIN 50 049	Certificates on material testings
DIN 50 111	Testing of metallic materials; technological bending test
DIN 50 114	Testing of metallic materials; tensile test on sheet and strip under 3 mm thick without using an extensometer
DIN 50 115	Testing of metallic materials; notched-bar impact bending test
DIN 50 120 Part 2	Testing of steel; tensile test on welded joints; pressure welded butt-joints
DIN 50 121 Part 2	Testing of metallic materials; technological bending test on welded joints and weld platings; pressure welded joints
DIN 50 124	Testing of metallic materials; tensile shear test on resistance spot welded, projection welded and fusion spot welded joints
DIN 50 125	Testing of metallic materials; tensile test specimens, directions for their preparation

DIN 50 145	Testing of metallic materials; tensile test
DIN 50 150	Testing of steel and cast steel; conversion table for Vickers hardness, Brinell hardness, Rockwell hardness and tensile strength
DIN 50 351	Testing of metallic materials; Brinell hardness testing
DIN 51 210 Part 1	Testing of metallic materials; tensile test on wires without extensometer measurement
Euronorm 20	Definitions and classification of steel grades
Stahl-Eisen-Prüfblatt 1805 ¹⁾ (Steel-Iron-Test Sheet)	Sampling and preparation of specimens for sample analysis of steels
Handbuch für das Eisenhüttenlaboratorium ¹⁾ Vol 2 (Handbook for the Ferrous Metallurgical Laboratory): The investigation of metallic materials; Düsseldorf, 1966	
Volume 5 (Supplement):	A 4.1 – List of recommended arbitration procedures, B – procedure for sampling C – analysis procedures; in each case the most recent edition

3 Definition

Steels for general structural purposes are unalloyed steels which are characterized essentially by their tensile strength and yield point at ambient temperature and are used, for example, in building above and below ground, bridge-building, hydraulic engineering, tank and bunker construction and in automotive and mechanical engineering.

Note: Classification into unalloyed and alloyed steels is dealt with by Euronorm 20.

4 Dimensions and permissible dimensional deviations

The nominal dimensions and the permissible dimensional deviations of the products are to be agreed if possible at the time of ordering with reference to the relevant dimensional Standards (see list at the end of this Standard).

5 Weights

In calculating the weight of all steels covered by this Standard a density of 7.85 kg/dm³ is assumed.

¹⁾ Publisher: Verein Deutscher Eisenhüttenleute
obtainable from: Verlag Stahleisen mbH,
Postfach 82 29, 4000 Düsseldorf 1

Table 1. Grade classification and chemical composition of the steels

Steel grade			Type of deoxidation 1)	Chemical composition in % by wt.											Steel grade								
Code number	Material number			Ladle analysis						Additional nitrogen combining elements (e. g. at least 0.020 % Al total)	Sample analysis												
	new	pre-vious		C					P		S	N 2)	C					P	S	N 2)			
				for product thicknesses in mm									for product thicknesses in mm										
max.					max.					max.													
St 33	1.0035	1.0033	optional	-	-	-	-	-	-	-	-	-	-	-	-	-	-	-	-	-	-	St 33	
St 37-2	1.0037	-	optional	0,17	0,20	0,20	0,20	0,20	by agreement	0,050	0,050	0,009	-	0,21	0,25	0,25	0,25	0,25	by agreement	0,065	0,065	0,010	St 37-2
USt 37-2	1.0036	1.0112	U	0,17	0,20	0,20	0,20	0,20		0,050	0,050	0,007	-	0,21	0,25	0,25	0,25	0,25		0,065	0,065	0,009	USt 37-2
RSt 37-2	1.0038	1.0114	R	0,17	0,17	0,17	0,20	0,20		0,050	0,050	0,009	-	0,19	0,19	0,19	0,22	0,23		0,060	0,060	0,010	RSt 37-2
St 37-3	1.0116	1.0116	RR	0,17	0,17	0,17	0,17	0,17		0,040	0,040	-	yes	0,19	0,19	0,19	0,19	0,19		0,050	0,050	-	St 37-3
St 44-2	1.0044	-	R	0,21	0,21	0,21	0,22	0,22	0,050	0,050	0,009	-	0,24	0,24	0,24	0,25	0,25	0,060	0,060	0,010	St 44-2		
St 44-3	1.0144	-	RR	0,20	0,20	0,20	0,20	0,20	0,040	0,040	-	yes	0,23	0,23	0,23	0,23	0,23	0,050	0,050	-	St 44-3		
St 52-3 ³⁾	1.0570	1.0841	RR	0,20 ⁴⁾	0,20 ⁴⁾	0,22	0,22	0,22	0,040	0,040	-	yes	0,22 ⁶⁾	0,22 ⁶⁾	0,24	0,24	0,24	0,050	0,050	-	St 52-3		
St 50-2	1.0050	1.0532	R	- ⁵⁾	- ⁵⁾	- ⁵⁾	- ⁵⁾	- ⁵⁾	-	0,050	0,050	0,009	-	-	-	-	-	-	0,060	0,060	0,010	St 50-2	
St 60-2	1.0060	1.0542	R	- ⁵⁾	- ⁵⁾	- ⁵⁾	- ⁵⁾	- ⁵⁾	-	0,050	0,050	0,009	-	-	-	-	-	-	0,060	0,060	0,010	St 60-2	
St 70-2	1.0070	1.0632	R	- ⁵⁾	- ⁵⁾	- ⁵⁾	- ⁵⁾	- ⁵⁾	-	0,050	0,050	0,009	-	-	-	-	-	-	0,060	0,060	0,010	St 70-2	

1) U rimming, R killed (including balanced steel), RR special killed
 2) It is permissible to exceed the maximum value indicated, provided a phosphorous content per 0,001 % N of 0,005 % P below the maximum value indicated is maintained. The nitrogen content may not, however, exceed a value of 0,012 % N in the ladle analysis and 0,014 % N in the sample analysis.
 3) The content may not exceed 0,55 % Si and 1,60 % Mn in the ladle analysis or 0,60 % Si and 1,70 % Mn in the sample analysis.
 4) Maximum 0,22 % C for steels KSt 52-3 and RoSt 52-3 according to Table 3
 5) In the case of steels suitable for bright drawing according to Table 3 the following guide values for the carbon content can be assumed:
 0,30 % C for ZSt 50-2, 0,40 % C for ZSt 60-2, 0,50 % C for ZSt 70-2
 6) Maximum 0,24 % C for steels KSt 52-3 and RoSt 52-3 according to Table 3

Table 2. Mechanical and technological properties of the steels in the as-delivered condition and/or condition of treatment according to Section 8.4.1.2

Steel grade according to Table 1		Mechanical and technological properties 1)								
		Tensile strength R_m			Upper yield point R_{eH}					
		for product thicknesses in mm			for product thicknesses in mm					
Code number	Material number	< 3	3 ≤ 100	> 100	≤ 16	> 16 ≤ 40	> 40 ≤ 63	> 63 ≤ 80	> 80 ≤ 100	> 100
		N/mm ²			N/mm ² min.					
St 33	1.0035	310 up to 540	290	-	185	175 5)	-	-	-	-
St 37-2	1.0037	360 up to 510	340 up to 470	by agreement	235	225	215	205	195	by agreement
USt 37-2	1.0036				235	225	215	215	215	
RSt 37-2	1.0038	275	265		255	245	235			
St 37-3	1.0116	355	345		335	325	315			
St 44-2	1.0044	430 up to 580	410 up to 540		295	285	275	265	255	
St 44-3	1.0144	510 up to 680	490 up to 630		335	325	315	305	295	
St 52-3	1.0570	490 up to 660	470 up to 610		365	355	345	335	325	
St 50-2	1.0050	590 up to 770	570 up to 710							
St 60-2	1.0060	690 up to 900	670 up to 830							
St 70-2	1.0070									

Handwritten note: * 290 - 510

1) The values of the tensile test and the bending test apply to longitudinal specimens apart from flat products ≥ 600 mm width from which transverse specimens are to be taken.

2) U hot formed, untreated, N normalized. Section 8.4.1.2 applies also.

3) For notched-bar impact specimens with a width of less than 10 mm the specifications according to Section 8.4.1.4 and Fig. 1 apply.

4) The test result is the average value from three tests. Only one individual value may be lower than the minimum average value of 23 or 27 J, and then only by a maximum of 30 %.

5) This value applies only to thicknesses up to 25 mm.

Table 2. (continued)

Steel grade	Code-number	Position of specimen	Mechanical and technological properties 1)																				
			Elongation at rupture							Bending test (180°)				Notched-bar impact work 4)									
			(Gauge length $L_0 = 80$ mm) for product thicknesses in mm							(a Thickness of specimen) for product thicknesses in mm				ISO V-notch specimens (longitudinal) for product thicknesses in mm									
$\geq 0,5$ < 1	≥ 1 < 1,5	$\geq 1,5$ < 2	≥ 2 < 2,5	$\geq 2,5$ < 3	≥ 3 < 40	> 40 ≤ 63	> 63 ≤ 100	> 100	< 3	≥ 3 ≤ 63	> 63 ≤ 100	> 100	Condition of treatment 2)	Test temperature 3) °C	≥ 10 ≤ 16	> 16 ≤ 63	> 63 ≤ 100	> 100					
%											Mandrel diameter				J								
min.															min.								
St 33		longitudinal transverse	10	11	12	13	14	18	-	-	-	longitudinal transverse	2,5a	3a	-	-	by agreement	U, N	-	-	-	-	
St 37-2	8		9	10	11	12	16	-	-	-	3a		3,5a	-	-	U, N			-	-	-	-	
USt 37-2	17		18	19	20	21	26	25	24	-	-		0,5a	1a	1,5a	-			U, N	+ 20	27	-	-
RSt 37-2	15		16	17	18	19	24	23	22	-	-		1,5a	2a	2,5a	-			U, N	+ 20	27	-	-
St 37-3	14		15	16	17	18	22	21	20	-	-		0,5a	1a	1,5a	-			U	± 0	27	27	23
St 44-2	12		13	14	15	16	20	19	18	-	-		1a	1,5a	2a	-			N	- 20	27	27	23
St 44-3	14		15	16	17	18	22	21	20	-	-		2a	2,5a	3a	-			U, N	+ 20	27	27	-
St 52-3	12		13	14	15	16	20	19	18	-	-		2,5a	3a	3,5a	-			U, N	± 0	27	27	23
St 50-2	12		13	14	15	16	20	19	18	-	-		2a	2,5a	3a	-			N	- 20	27	27	23
St 60-2	8		9	10	11	12	16	15	14	-	-		2,5a	3a	3,5a	-			U	± 0	27	27	23
St 70-2	6	7	8	9	10	14	13	12	-	-	3a	3,5a	-	-	N	- 20	27	27	23				
	4	5	6	7	8	11	10	9	-	-	-	-	-	-	U, N	-	-	-	-				
	3	4	5	6	7	10	9	8	-	-	-	-	-	-	U, N	-	-	-	-				

1), 2), 3) and 4) see page 4

341

6 Grade classification

6.1 This Standard covers the steel grades listed in Tables 1 and 2 which are available in the quality groups indicated there (see Section 7). The steels of quality group 3 differ from those in quality group 2, particularly because they must meet higher requirements of insusceptibility to brittle failure (see test temperature for notched-bar impact work in Table 2). They are thus also more suitable for welding (see Section 8.4.2). The higher requirements of insusceptibility to brittle failure of steels in quality group 3 necessitate higher requirements in respect of the deoxidation and chemical composition of these steels (see Table 1).

6.2 Table 3 shows the steel grades which, in addition to the properties stated in Tables 1 and 2, are suitable for forming (see Sections 8.4.3.2 to 8.4.3.6), and where there are special requirements these steels can be ordered with special code letters in the code number and their own material number.

7 Designation of the steels

7.1 The full code number of the steel grades can be found in Tables 1 to 3. It consists generally of the code letter St, the identification number of the steel grade and the reference number of the quality group, e. g. St 52-3.

7.1.1 The code number must be prefixed with the appropriate code letter (U or R) if a particular type of deoxidation is desired and there is scope for choice in the matter (e. g. USt 37-2 or RSt 37-2).

7.1.2 In the case of steels with particular service properties the code letter given in Table 3 is to be used in the code number, e. g. QSt 52-3 or RPSt 37-2.

7.1.3 For the following steels with copper added according to Section 8.4.4.3, code numbers and material numbers have been specified:

RSt 37-2 Cu3	1.0167
St 37-3 Cu3	1.0166
St 52-3 Cu3	1.0585
UQSt 37-2 Cu3	1.0164
RQSt 37-2 Cu3	1.0170
QSt 52-3 Cu3	1.0587

7.1.4 The as-delivered condition of the products need only be indicated in the code number if it departs from the normal type according to Section 8.2. In this case the code letter U must be added to the code number if the product is to be delivered in the hot-formed untreated condition (e. g. USt 37-2 U) and the code letter N must be added if the product is to be delivered in the normalized condition (e. g. USt 37-2 N).

7.2 The code number or the material number for the steel grade shall be included in the standard designation for the product as indicated in the examples in the dimensional Standards.

Table 3. Steel grades with special service properties (see Section 6.2)

Steel grade according to Tables 1 and 2	Folding ¹⁾ (Q)		bright drawing ²⁾ (Z)		Steels suitable for drop forging ³⁾ (P)		section rolling ³⁾ (K)		Manufacture of welded tubes ⁵⁾ (Ro)	
	Code number	Material number	Code number	Material number	Code number	Material number	Code number	Material number	Code number	Material number
St 33	—	—	—	—	—	—	—	—	—	—
St 37-2	—	—	ZSt 37-2	1.0159	—	—	KSt 37-2	1.0113	—	—
USt 37-2	UQSt 37-2	1.0121	UZSt 37-2	1.0161	—	—	UKSt 37-2	1.0124	URoSt 37-2	1.0173
RSt 37-2	RQSt 37-2	1.0122	RZSt 37-2	1.0165	RPSSt 37-2	1.0172	RKSt 37-2	1.0125	RRoSt 37-2	1.0174
St 37-3	QSt 37-3	1.0123	ZSt 37-3	1.0168	PSt 37-3	1.0176	KSt 37-3	1.0127	RoSt 37-3	1.0175
St 44-2	QSt 44-2	1.0128	ZSt 44-2	1.0129	PSt 44-2	1.0146	KSt 44-2	1.0148	RoSt 44-2	1.0149
St 44-3	QSt 44-3	1.0133	ZSt 44-3	1.0153	PSt 44-3	1.0135	KSt 44-3	1.0137	RoSt 44-3	1.0138
St 52-3	QSt 52-3	1.0573	ZSt 52-3	1.0597	PSt 52-3	1.0572	KSt 52-3	1.0575	RoSt 52-3	1.0576
St 50-2	—	—	ZSt 50-2	1.0533	PSt 50-2	1.0538	—	—	—	—
St 60-2	—	—	ZSt 60-2	1.0543	—	—	—	—	—	—
St 70-2	—	—	ZSt 70-2	1.0633	—	—	—	—	—	—

¹⁾ Including suitability for cold bending, cold flanging and cold beading (see Section 8.4.3.2)

²⁾ See Sections 8.4.3.5 and 8.5.4

³⁾ See Sections 8.4.3.6 and 8.5.3

⁴⁾ Additionally suitable for the manufacture of cold formed hollow sections (see Section 8.4.3.3)

⁵⁾ See Section 8.4.3.4

8 Requirements

8.1 Manufacturing process

8.1.1 The melting process for steel grade St 33 is determined by the manufacturer and is not notified.

For steel grades of quality groups 2 and 3 the decision on melting process is likewise left to the manufacturer, unless agreed to the contrary at the time of ordering; the process must, however, be notified to the customer on request.

8.1.2 The type of deoxidation of the steels is according to Table 1. In the case of steels St 33 and St 37-2 (but not in the case of USt 37-2 and RSt 37-2) it is left to the choice of the manufacturer and is not notified to the customer.

8.1.3 The forming process is decided by the manufacturer, unless otherwise agreed.

8.1.4 Further data on the manufacturing process is notified only if so agreed at the time of ordering.

8.2 As-delivered condition of the products

8.2.1 Unless otherwise agreed at the time of ordering the products are delivered in the following conditions:

- Plate, sheet and wide flats in the condition indicated in Table 4,
- Forgings in the normalized condition (N),
- All other products in the untreated, i. e. hot-formed condition, or in the case of semi-finished products also in the continuously-cast condition (see also Sections 7.1.4 and 8.4.1.2).

8.2.2 Normalizing can be replaced by equivalent temperature control during and after hot-forming.

Table 4. Usual as-delivered condition of plate, sheet and wide flats (see Sections 8.2.1 and 8.2.2)

Steel grade	As-delivered condition ¹⁾ for				
	plate and sheet for thicknesses in mm			wide flats thicknesses in mm	
Code number	≤ 4,75	> 4,75 ≤ 25	> 25	≤ 25	> 25
St 33	N	U	U	U	U
St 37-2 USt 37-2 RSt 37-2 St 44-2	N	U	N	U	N
St 50-2 St 60-2 St 70-2	N	N	N	N	N
St 37-3 St 44-3 St 52-3	N	N	N	N	N

¹⁾ N normalized, U hot rolled, untreated

8.3 Chemical composition

8.3.1 The values in Table 1 apply to the chemical composition (ladle and sample analysis). In addition (except for steels St 33, St 50-2, St 60-2, and St 70-2) the

contents of the elements not listed in Table 1 must not exceed the maximum values given in Euronorm 20 (September 1974 edition).

8.3.2 Verification of the sample analysis data during the acceptance test must be subject to special agreement. Such verification does not apply to steels St 33 and St 37-2.

8.4 Mechanical and technological properties

8.4.1 Properties in the tensile test, notched-bar impact bending test ("impact test") and bending test

8.4.1.1 In the tensile test according to Section 9.5.3, in the notched-bar impact bending test according to Section 9.5.6 and in the bending test according to Section 9.5.5 on specimens taken and prepared in accordance with the data in Section 9.4 and which are available in the conditions of treatment indicated in Section 8.4.1.2, the requirements given in Table 2 must be met.

8.4.1.2 The requirements given in Table 2 apply in the case of semi-finished products to normalized reference samples prepared in accordance with Section 9.4.3.1.2,

in the case of wire rod to normalized reference or deliveries,

in the case of all other products to the usual as-delivered condition according to Section 8.2.1.

If for usually normalized products the delivery is ordered in the hot-formed untreated condition, the requirements given in Table 2 do not apply to the as-delivered condition but only to normalized reference samples.

Note: In the case of welded hollow sections the strength values (R_m and R_e) given in Table 2 also apply to the weld.

8.4.1.3 Thickness is taken, in accordance with the data in Table 2 in the case of simple uniform cross-sections, as the nominal dimension, in the case of sections the thickness of that part of the section from which the sample will be taken (see Figs 2 to 7), in the case of other sections with uneven cross-sections the thickness of the largest flat portion.

In the case of forgings the thickness is to be determined as appropriate.

8.4.1.4 If as a result of low product thicknesses the notched-bar impact work (absorbed energy) values can be verified only on specimens with a width of below 10 mm but at least 5 mm, then instead of the minimum value of 27 J given in Table 2 the minimum value of the notched-bar impact work resulting from Fig. 1 for the relevant specimen width applies.

8.4.1.5 If in the case of products of quality group 3 it is not possible to carry out a test of notched-bar impact work (e. g. in the case of thicknesses below 5 mm), an adequate content of nitrogen-fixing elements is valid as verification of the required insusceptibility to brittle failure.

8.4.1.6 In the case of products made from steels of quality group 3 in thicknesses of 25 to 50 mm, in addition to the requirements of notched-bar impact work for further assessment of insusceptibility to brittle failure or suitability for welding, the requirements of the weld bead bend test in accordance with Section 9.5.7 must be met on the basis of agreement reached at the time of ordering.

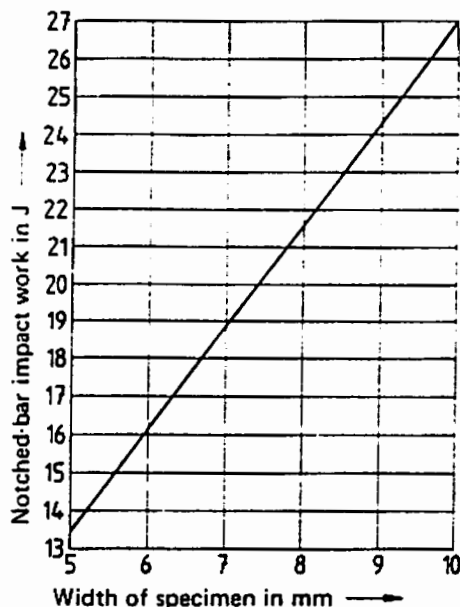

Figure 1. Minimum values of notched-bar impact work with specimens of width between 5 and 10 mm.

8.4.2 Suitability for welding

8.4.2.1 Unlimited suitability of the steels for the various welding processes cannot be guaranteed, since the behaviour of a steel during and after welding depends not only on the material but also on the dimensions and shape of the component and also the conditions it experiences in manufacture and service ²⁾.

8.4.2.2 Steels of quality group 2 and 3 up to and including St 52-3 (i. e. the steels according to this Standard with a maximum carbon content of 0.22 % in the ladle analysis) are generally suitable for arc welding and gas fusion welding. Here, given the same minimum yield point, the steels of quality group 3 are preferable to those of quality group 2, and within quality group 2 killed steels are preferable to rimming steels, particularly if segregation zones may be encountered during welding.

Depending on welding conditions and conditions in service, steel St 33 is also suitable, subject to restriction to arc welding and gas fusion welding. Steels St 50-2, St 60-2 and St 70-2 are not designed for arc welding and gas fusion welding.

8.4.2.3 Suitability for flash butt-welding and gas pressure welding generally exists with all the steels of this Standard; but it may be necessary in the case of steels with higher carbon content (St 50-2, St 60-2 and St 70-2) to carry out reheating after welding.

8.4.2.4 Suitability for pressure welding by other processes generally exists only with the steels of Table 1 having not more than 0.22 % C in the ladle analysis; it is

also influenced to a great extent by the silicon content of the steel.

Depending on the carbon content, reheating may be necessary.

8.4.3 Deformability

8.4.3.1 The steels are suitable for hot and cold forming, i. e. they must be neither cold-short nor red-short. In the bending test they must be capable of being bent for 180° round the mandrel diameters stated in Table 1 without showing any cracks on the side in tension.

8.4.3.2 Flats up to 20 mm thickness from the steels with the code letter Q as in Table 3 are supplied with special suitability for cold bending, folding, cold flanging or cold beading with internal bending radii in accordance with Table 5. Flats with rolled-in pattern cannot be supplied in Q grades.

8.4.3.3 Strip from steels with the code letter K in Table 3 is delivered in thicknesses up to 8 mm with suitability for the manufacture of cold rolled sections on rolled section machines (see DIN 59 413) and in thicknesses up to 12.5 mm with suitability for the manufacture of cold forming hollow sections (see DIN 59 411). The suitability applies to the bending radii stipulated in DIN 59 411 and DIN 59 413. For strip thicknesses over 8 mm or over 12.5 mm the internal bending radii according to Table 5 apply.

8.4.3.4 For semi-finished products and flats used for the manufacture of tubes in accordance with DIN 1626 Part 1 to Part 4, special agreements should be made in respect of different conditions of tube manufacture at the time of ordering. This covers the steel grades of Table 3 marked with the code letters Ro.

8.4.3.5 Steels with the code letter Z in accordance with Table 3 are delivered with suitability for bright drawing (see Section 8.5.4).

8.4.3.6 Steels with the code letter P in accordance with Table 3 are delivered with suitability for drop forging (see Section 8.5.3).

²⁾ See also DIN 8528 Part 1 and DIN 8528 Part 2 and also DAST-Richtlinie (DAST-Directive) 009 (issued by the Deutscher Ausschuss für Stahlbau (German Committee for Structural Steel Engineering); April 1973) and the "Katalog zur Wahl der Stahlgütegruppen für geschweisste Stahlbauten" (Catalogue for selecting steel quality groups for welded steel structures) issued by the Technischer Ausschuss des Deutschen Verbandes für Schweisstechnik, 1964) (Technical Committee of the German Welding Association). (See Explanations)

Table 5. Minimum values for the bending radii for cold bending, folding, cold flanging or cold beading of flats and for the manufacture of cold rolled sections and of cold formed hollow sections (see Sections 8.4.3.2 and 8.4.3.3).

Steel grade Code number	Bending edge transverse or longitudinal to rolling direction	Minimum permissible bending radius for thicknesses in mm														
		1	> 1 ≤ 1,5	> 1,5 ≤ 2,5	> 2,5 ≤ 3	> 3 ≤ 4	> 4 ≤ 5	> 5 ≤ 6	> 6 ≤ 7	> 7 ≤ 8	> 8 ≤ 10	> 10 ≤ 12	> 12 ≤ 14	> 14 ≤ 16	> 16 ≤ 18	> 18 ≤ 20
UQSt 37-2 RQSt 37-2 QSt 37-3	transverse	1	1,6	2,5	3	5	6	8	10	12	16	20	25	28	36	40
	longitudinal	1	1,6	2,5	3	6	8	10	12	16	20	25	28	32	40	45
QSt 44-2 QSt 44-3	transverse	1,2	2	3	4	5	8	10	12	16	20	25	28	32	40	45
	longitudinal	1,2	2	3	4	6	10	12	16	20	25	32	36	40	45	50
QSt 52-3	transverse	1,6	2,5	4	5	6	8	10	12	16	20	25	32	36	45	50
	longitudinal	1,6	2,5	4	5	8	10	12	16	20	25	32	36	40	50	63

8.4.4 Other requirements

8.4.4.1 If longitudinal cutting-off of sections is intended, e. g. of wide flanged beams in the web, this must be specially indicated at the time of ordering.

8.4.4.2 For steels with stressing in the thickness direction the Iron and Steel Conditions of Delivery 096 ¹⁾ Plate, Strip and Wide Flats with improved properties for stressing vertical to the surface of the product must be observed.

8.4.4.3 In the case of the steel grades named in Section 7.1.3 the copper content in the ladle analysis must be between 0.25 and 0.35 %. Otherwise the same requirements apply to these steel grades as to the corresponding grades without added copper.

8.4.4.4 Suitability for the application of surface coatings (hot galvanizing, enamelling and comparable processes) must be agreed at the time of ordering.

8.5. Surface condition

8.5.1 Rolled products shall have a smooth surface consistent with the forming process used.

Note: See also Iron and Steel Conditions of Delivery 071 ¹⁾ Surface condition of hot rolled heavy plate, medium plate and wide flats.

8.5.2 Surface defects in excess of the permitted imperfections (see Section 8.5.1) must be removed by suitable means. The depressions formed in this way must be levelled out. Unless otherwise agreed at the time of ordering, the permissible thickness deviations stipulated in the dimensional Standards and any machining allowances provided for must be observed. The use of welding to rectify surface defects is only permitted subject to the approval of the customer.

8.5.3 Steel to be converted into drop forgings or otherwise machine-forged must satisfy special requirements with regard to the surface condition (see Section 8.4.3.6).

8.5.4 Suitability for bright-drawing requires a special surface (see Section 8.4.3.5).

8.5.5 In the case of steel products with added copper, the appearance of the surface can sometimes be impaired.

9 Testing

9.1 General

The manufacturer must supervise production by carrying out his own measurements and on his own responsibility by methods which suit him, with regard to the requirements specified in Section 8.

9.2 Agreement on tests and certificates covering material tests

9.2.1 The customer can agree with the limitations indicated in Sections 9.2.2 and 9.2.4 for all steel grades the issuing of one of the certificates on material tests in accordance with DIN 50 049.

9.2.2 For steel St 33 only a statement of compliance with the order may be issued.

9.2.3 If the issue of a works report was agreed then it must contain, for all steels except St 33, results of tensile tests; for flats made of steels in quality group 3 it is additionally necessary to give results of notched-bar impact tests.

9.2.4 In the case of delivery by casts which does not apply to steel St 33, the issue of a works report in which the chemical composition according to the ladle analysis is given can be agreed.

For steel St 37-2 (without stipulated type of deoxidation), however, a test certificate will give only the values for the carbon, phosphorus, sulphur and nitrogen contents.

9.2.5 If the issue of a certificate was agreed which, in accordance with DIN 50 049, requires tests to be carried out on the delivery itself, the stipulations laid down in Sections 9.3 to 9.6 apply.

9.3 Extent of tests

9.3.1 Tests to be carried out

9.3.1.1 If a certificate was ordered covering tests to be carried out on the delivery itself the following must be carried out in any case:

- in the case of all steels except St 33, the tensile test,
- in the case of flats made of steel in quality group 3, also the notched-bar impact bending test ("impact test") (see Section 8.4.1.5).

¹⁾ See page 2

9.3.1.2 At the time of ordering further acceptance tests, in addition to those mentioned in Section 9.3.1.1, may be agreed, e. g.:

- a) in the case of all steels except St 33, St 50-2, St 60-2 and St 70-2, the bending test (which should not, however, be asked for in addition to the notched-bar impact bending test),
- b) in the case of products made of steels in quality group 2 (apart from St 50-2, St 60-2 and St 70-2) and products made of steels in quality group 3 (unless already covered under Section 9.3.1.1 b): the notched-bar impact bending test (see Section 8.4.1.5),
- c) in the case of all steels except St 33 and St 37-2: sample analysis, if the products are to be delivered separately by casts (see Section 9.3.3.1),
- d) in the case of the products named in Section 8.4.1.6: the weld bending test.

9.3.2 Test unit and number of specimens for sample analyses

9.3.2.1 The cast is the test unit.

9.3.2.2 Unless otherwise agreed at the time of ordering, one specimen per cast is to be taken (see Section 9.4.2).

9.3.3 Test units and number of specimens for mechanical and technological tests

9.3.3.1 The number of specimens is governed by whether delivery is on a cast or lot basis. Delivery is in the case of quality group 2 by lots or casts, in the case of quality group 3 by casts.

For products of steels of quality group 2 it must be agreed at the time of ordering whether delivery shall be on the basis of casts or lots.

Even when ordering on a lot basis the supplier is allowed to test by casts if presentation for testing is by casts.

9.3.3.2 The test units are

40 t for testing by casts,

20 t for testing by lots,

or in each case a smaller quantity presented for testing.

In the case of strip with roll-weights above 20 t it is sufficient to test every second roll.

9.3.3.3 For each test unit and thickness range (see the scale of thicknesses for the yield point in Table 2) in order to verify the values, the following shall be taken

one specimen for the tensile test,

one specimen for the bend test (where this has been agreed, see Section 9.3.1.2 a) and

where a notched-bar impact bending test has been agreed, one sample section which must be sufficient to make six specimens.

9.3.3.3.1 For all tests, in one test unit, the maximum product thickness may be at most double the minimum product thickness. Unless otherwise agreed at the time of ordering the samples are to be taken from a product of average thickness.

9.3.3.3.2 In the case of flats from steel of quality group 3, agreement can be made to carry out a test for the notched-bar impact work on each sheet or on each roll.

9.3.3.3.4 For the notched-bar impact tests three specimens are to be taken from the test piece according to Section 9.3.3.3. The test is confined to these three specimens if their results conform with the values in Table 2.

9.3.3.5 If the carrying out of a weld bending test is agreed, one single specimen is to be taken per cast.

9.4 Sampling

9.4.1 General

The points from which the specimens are taken shall be so situated in the workpiece as to give the clearest possible indication of the properties throughout the cross-section and the length.

9.4.2 Specimens for the sample analysis

The specimens for testing the chemical composition in the piece shall be taken according to Stahl-Eisen-Prüfblatt 1805 (Steel-Iron Test Sheet) ¹⁾.

9.4.3 Specimens for the mechanical and technological tests

9.4.3.1 Position of the specimens

9.4.3.1.1 For the tensile test and the bend test the samples must be taken longitudinally (parallel to the rolling direction) from the finished products except in the case of flats of ≥ 600 mm width, from which transverse samples must be taken.

For the notched-bar impact bending test the samples should in principle be taken longitudinally from the product.

In particular the data in Section 9.4.3.2 apply.

9.4.3.1.2 In the case of semi-finished products reference samples of maximum 20 mm square should be made from the product where possible by hot forming over the whole cross-section and then normalized.

In the case of semi-finished products for forging purposes larger sample cross-sections can be agreed.

9.4.3.1.3 In the case of semi-finished products which are subject to further heat treatment, mechanical tests can be omitted; the required delivery must then be assessed according to the chemical composition of the casts. Only if there is doubt about them or if verification of the properties has been expressly agreed at the time of ordering, are specimens to be tested in accordance with Section 9.4.3.1.2. The tensile strength can also be estimated from the hardness test (see Section 9.5.4).

9.4.3.2 Points from which samples are taken

9.4.3.2.1 Specimens for the tensile test

9.4.3.2.1.1 In the case of sections the specimens should be taken from the points shown in Figs 2 to 7, preferably from the flange, the longitudinal axis of the specimens being situated at about one-third of the way from one of the edges to the axis of the section. When test bars are taken from channel sections it is permissible for the specimens to be moved away from the radius region and into the flange.

9.4.3.2.1.2 In the case of steel bars and wire rod up to 25 mm thickness or diameter, the test piece shall be removed in such a way that it can be used as a specimen with the minimum amount of machining. In the case of thicknesses or diameters over 25 and up to 40 mm, the specimens can be taken from the cross-section in any way whatever. In the case of steel bars over 40 mm thick the test bars shall in principle be taken from a point one-third of the way between the surface or edge and the longitudinal axis — starting from the surface or edge — or as near as possible to this point (see Figs 9 to 11).

¹⁾ See page 2

1-43

In the case of wire rod, the specimen is to be taken at a point sufficiently far away from the end of the coil. In arbitration tests the minimum distance of the specimen from the end of the coil as shown in Table 6 applies.

Table 6. Position of specimens when testing wire

Diameter of wire rod (or diameter of the circle equal in area) mm	Distance from the ends of the coil m min.
$\geq 5 \leq 6,5$	5
$> 6,5 \leq 12,5$	4
$> 12,5 \leq 17,5$	3
$> 17,5 \leq 22$	2
$> 22 \leq 27$	1,5
$> 27 \leq 30$	1

9.4.3.2.1.3 In the case of flats ≥ 600 mm in width the test pieces shall generally be taken in such a way that they are positioned half-way between the longitudinal edges and centre line (see Fig. 12).

9.4.3.2.1.4 In the case of strip the test piece shall be taken from the outer turn at an adequate distance from the end of the strip. In the case of hot rolled strip below 600 mm in width the test pieces shall be taken at a distance of approximately 1000 mm from the end of the strip and of one-third of width of the strip from the edge.

9.4.3.2.1.5 In the case of hollow steel sections the specimens must be taken outside the area of the weld as shown in Fig. 13.

9.4.3.2.1.6 When flat specimens are taken for the tensile test, then for products up to 30 mm thick both rolled surfaces should generally be left on the specimen. On rectangular specimens of products over 30 mm thick at least one rolled surface should be retained. Round specimens are permitted but should be provided only when the thickness exceeds 30 mm; the specimens should then be taken in such a way that their axis lies one-third of the distance between the surface and the centre — starting from the surface — or as near as possible to this point.

9.4.3.2.2 Specimens for the bending test

The points from which the specimens should be taken for the bending test are given in Section 9.4.3.2.1. The specimens used should, if possible, be of the full thickness of the product. In the case of product-thickness above 30 mm the specimens may be machined down on one side (see Section 9.5.5).

9.4.3.2.3 Specimens for the notched-bar impact bending test

The points from which the specimens should be taken for the notched-bar impact bending test are given in Section 9.4.3.2.1. One side of the specimen should be placed as close as possible to the rolled surface. The notch should be made perpendicular to the rolled surface (see Fig. 8).

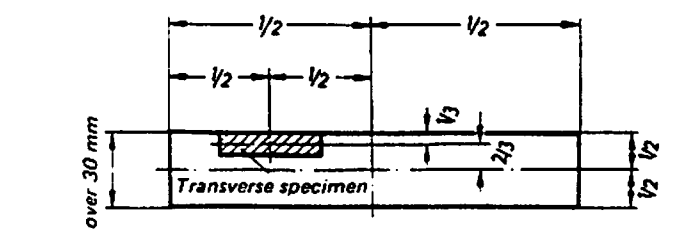
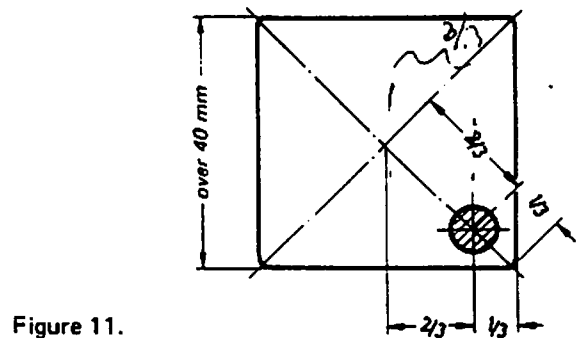
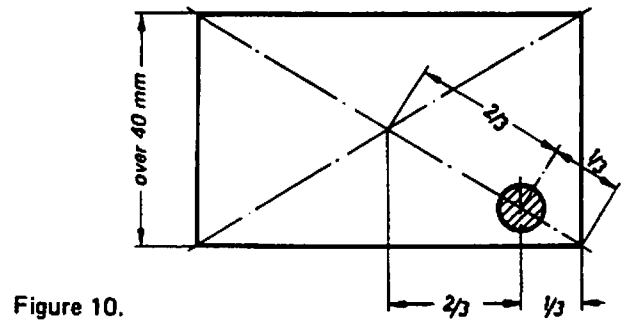
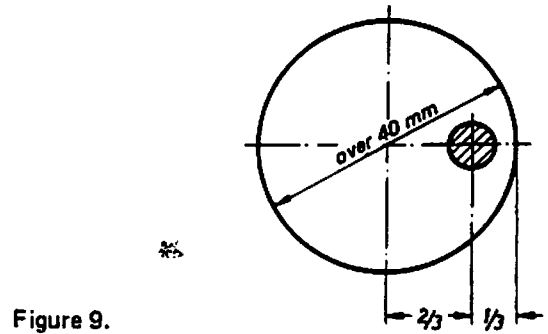
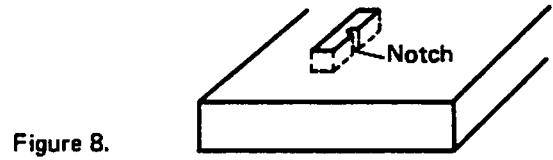
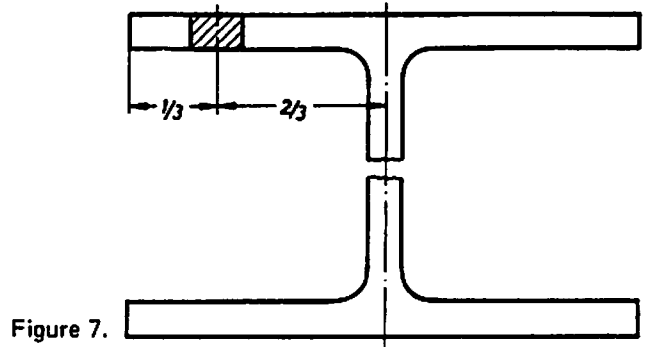
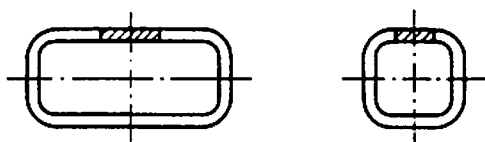
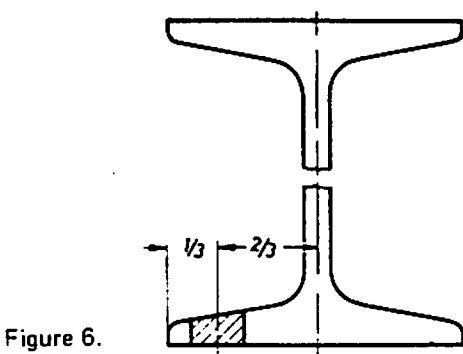
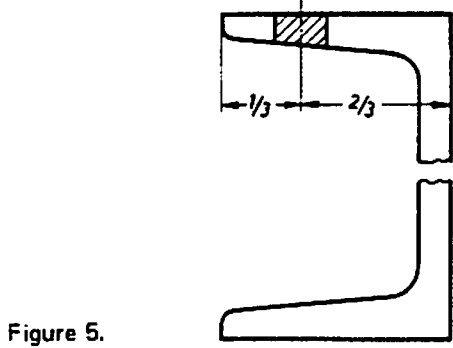
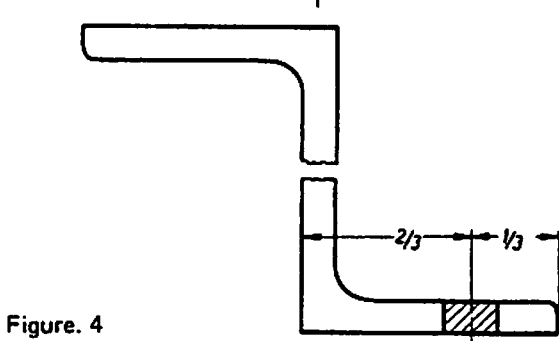
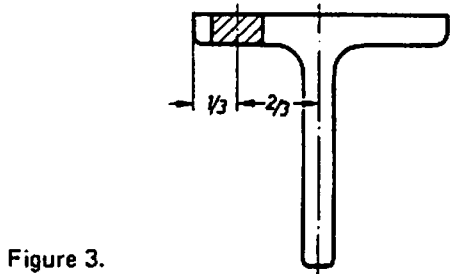
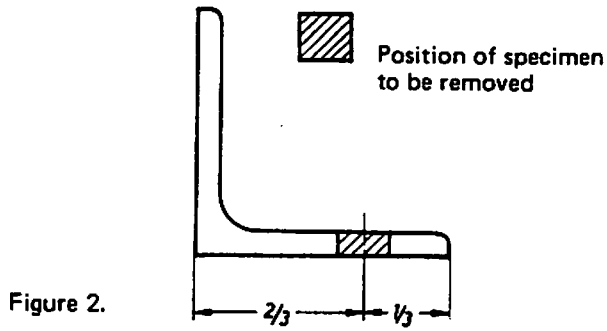

Figure 12.

125

9.4.3.3 Machining of test pieces and specimens

9.4.3.3.1 Deformation shall be avoided as far as possible when cutting out the specimens; if guillotines or flame cutters are used an adequate allowance must be left for machining off. If the hardening induced by flame cutting does not permit machining, heating to not more than 550 °C is permissible. Rolled steel test pieces deformed by bending or twisting shall principally be cold-straightened. If the amount of deformation is too severe for cold-straightening, the straightening can be done hot in the case of material to be delivered normalized, but the temperature must not exceed 520 °C.

9.4.3.3.2 During preparation of the specimen it is important to avoid any cold working or temperature rise which would impair on the specimens properties differing from those of the products as-delivered.

9.5 Test methods to be applied

9.5.1 The chemical composition shall be tested by the method described by the Chemists' Committee of the Verein Deutscher Eisenhüttenleute (Association of German Metallurgists) (see Section 2).

9.5.2 The mechanical and technological tests are to be carried out at room temperature (about 20 °C) unless a lower temperature is specified for the notched-bar impact tests.

9.5.3 The tensile test is to be carried out according to DIN 50 145.

9.5.3.1 Normally the tensile test shall be carried out using short proportional bars with gauge length $L_0 = 5 d_0$ (for rectangular specimens $L_0 = 5.65 \cdot \sqrt{\text{cross-section}}$) according to DIN 50 125, for wire rod ≤ 6 mm diameter according to DIN 51 210 Part 1. In borderline cases and for arbitration tests the use of these specimens – with the exception of flats according to Section 9.5.3.2 – is mandatory.

9.5.3.2 On flats with less than 3 mm thickness the tensile test must be carried out with a specimen of gauge length $L_0 = 80$ mm and width $b_0 = 20$ mm according to DIN 50 114.

9.5.3.3 In addition to the specimens according to Section 9.5.3.1 it is permissible, in the routine testing of flats, to use flat specimens which are easier to prepare with a gauge length of $L_0 = 100$ mm for products from 3 to 5 mm thick inclusive and of $L_0 = 200$ mm for products over 5 mm thick.

The maximum width of specimen	may be	for product thicknesses
up to 60 mm		over 3 up to 10 mm
up to 50 mm		over 10 up to 25 mm
up to 35 mm		over 25 up to 50 mm
up to 20 mm		over 50 mm.

In such cases the minimum elongation at fracture obtained must be that evaluated from the figures in Table 2 multiplied by the conversion factors in Table 7. In case of doubt and for arbitration tests only, the results obtained from a bar with $L_0 = 5 d_0$ must be used.

Table 7. Conversion factors for elongation at fracture

Gauge length mm	Conversion factor for tensile specimen cross-sections in mm ²								
	up to 25	26 to 100	101 to 225	226 to 400	401 to 625	626 to 900	901 to 1600	1601 to 2500	2501 to 3600
100	0,7	0,8	0,9	1,0	1,1	1,2	–	–	–
200	0,7	0,7	0,8	0,8	0,9	0,9	1,0	1,1	1,2

Note: The following example is given to illustrate the use of the conversion factors. From Table 2 an RSt 37-2 steel plate 4 mm thick must show an elongation at fracture of not less than 24 % for $L_0 = 5 d_0$. If a specimen with a cross-section of 4 mm X 30 mm = 120 mm² is used then the elongation at fracture for a gauge length of $L_0 = 100$ mm must be not less than $24 \times 0.9 = 21.6$ %.

9.5.4 As an approximation the tensile strength can be derived from the Brinell hardness which is determined according to DIN 50 351 by using the comparison table in DIN 50 150. For acceptance purposes, however, the tensile test remains the criterion.

9.5.5 The bending test is to be carried out according to DIN 50 111. During the test the specimen is placed so that the side with the rolling skin lies in the tension zone.

9.5.6 The notched-bar impact bending test ("impact test") on ISO V-notch specimens is to be carried out according to DIN 50 115 (see Section 8.4.1.5).

9.5.7 For the welding bend test a specimen (see Fig. 14) of the same thickness as the product is provided in the middle with a 6 s long semi-circular longitudinal groove, with a diameter of 4 mm. In the case of products with webs, lips etc., the parts projecting out of the plane of the specimen must be machined off prior to welding; in this case the longitudinal groove is made in the unmachined side. The groove is then filled in with a suitable filler metal (5 mm diameter) at about 20 °C in a single run; the bead is not machined off. No further alteration may be made to the specimens after welding. For the bending test the specimen is placed in the bending jig in such a way that the welding bead lies in the tension zone (see Fig. 15).

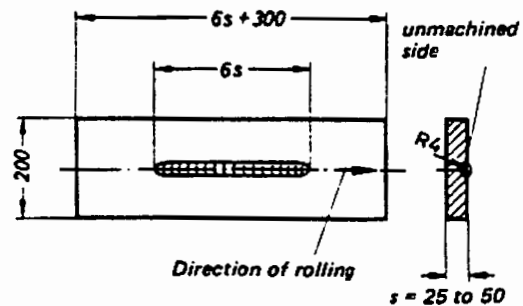

Figure 14. Specimen for the welding bend test

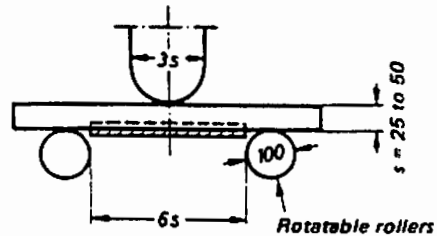

Figure 15. Welding bend test

In the welding bend test rolled products must show a tough deformation fracture (not a brittle fracture). The bending angle at which the first evidence of cracking appears in the weld shall be noted in the test record. The test shall be continued to failure or at least to a bending angle of 90°. A (brittle) fracture without deformation is when the specimen material fails to hold after cracks occur in the weld metal. When the first signs of cracking appear, cracks extending from the weld no further than 20 mm into the material shall be disregarded. Obvious welding defects shall not be classed as failures.

9.5.8 For testing suitability for welding by pressure in special cases, the tests according to DIN 50 120 Part 2 and DIN 50 121 Part 2 are used for butt welds; for resistance spot welded joints the tests according to DIN 50 124 are used.

9.5.9 The surface condition shall be checked by visual inspection, i. e. without special optical aids.

9.6 Retests

9.6.1 Test results which are due to incorrect removal and preparation of the specimen, to deficiencies in testing or to an accidentally, closely defined defect in a specimen shall be disregarded.

9.6.2 If the unsatisfactory result of a test is due to incorrect heat treatment of the products, the heat treatment can be carried out again, whereupon the entire test must be repeated.

9.6.3 If the specimens are satisfactory but do not meet the specified requirements the procedure adopted shall be as follows:

9.6.3.1 If the tensile specimen, bending specimen or welding bend test specimen is unsatisfactory then — except in the case of strip and wire rod — the piece from which the specimen was taken shall be rejected. The test shall be repeated on one specimen from each of two different pieces from the same test unit and both of these must satisfy the requirements.

9.6.3.2 If the results of the three notched-bar specimens tested do not meet the requirements, then three further specimens are taken from the test piece according to Section 9.3.3.3 and tested. The average from the six individual tests must then meet the requirements. Of the six individual values only two may lie below the required minimum value, of which no more than one individual value shall differ from the minimum value by more than 30 %.

If the results of this retest are unsatisfactory — except in the case of strip and wire rod — the piece which has been tested is rejected and two further pieces from the same test unit of the same or immediately following smaller thickness are tested. If one of these pieces fails to satisfy the requirements, either the test unit shall be rejected or, subject to special agreement, the remainder of the test unit shall be tested piece by piece.

9.6.3.3 In the case of strip and wire rod the retest specimens must be taken from the rolls or coils to which objection is made, after cutting off a further length.

9.6.3.4 The manufacturer reserves the right to subject rejected pieces or test units to heat treatment and to present them again for testing.

10 Marking

10.1 If specially agreed at the time of ordering, marking of the products can be carried out and in this connection the stipulations of DIN 1599 (Preliminary Standard) are to be observed. In the case of an acceptance test the marking described in Section 10.2 is taken as agreed.

10.2 The marking generally consists in the case of St 33 of the code number for the steel grade and the mark of the manufacturing works,

in the case of steels of quality groups 2 and 3 the above details plus the heat number (if supplied on a heat basis) and where appropriate the specimen number and, when test certificates or certificates of acceptance are issued, the inspector's mark.

11 Complaints³⁾

11.1 External and internal defects may only be objected to if they impair to an appreciable extent the working and utilization in a manner appropriate to the grade of steel and form of product concerned.

11.2 The customer must give the supplier the opportunity of convincing himself that the complaints are justified, where possible by submitting the material objected to, as well as specimens of the material as-supplied.

Note: After the adoption of DIN 17 010 General technical conditions of delivery for steel and steel products (at present in draft form) the stipulations made therein on complaints apply in each case, even if they differ from the contents of Section 11 above (see Explanations).

Dimensional Standards which apply to products made of steels for general structural purposes

Hot rolled products

DIN 1013 Part 1	Steel bars; hot rolled round steel for general purposes; dimensions, permissible variations on dimension and form
DIN 1013 Part 2	Steel bars; hot rolled round steel for special purposes; dimensions, permissible variations on dimension and form
DIN 1014 Part 1	Steel bars; hot rolled squares for general purpose; dimensions, permissible deviations on dimension and form
DIN 1014 Part 2	Steel bars; hot rolled squares for special purpose; dimensions, permissible deviations on dimension and form
DIN 1015	Steel bars; hot rolled hexagon steel; dimensions, weights, permissible variations
DIN 1016	Flat products of steel; hot rolled strip, hot rolled sheet under 3 mm thickness, dimensions, permissible variations on dimension, form and weight
DIN 1017 Part 1	(Subsequent edition at present in draft form) Steel bars; hot rolled flat steel for general purpose, dimensions, weights, permissible variations
DIN 1017 Part 2	Steel bars; hot rolled flat steel for special purpose (in bar drawing mills, bolt and screw factories etc.), dimensions, weights, permissible variations
DIN 1018	Steel bars; hot rolled half-round steel and half-oval steel, dimensions; weights, permissible variations
DIN 1022	Steel bars; hot rolled equal angle squared-edge steel (LS Steel), dimensions, weights, permissible variations
DIN 1024	Steel bars; hot rolled round-edge T-bars, dimensions, weights, permissible variations, static values

³⁾ For Explanations of this complaints clause in quality Standards for iron and steel, see DIN-Mitteilungen (DIN News), Vol 40 (1961) No. 2, Page 111/112.

DIN 1025 Part 1	Steel sections; hot rolled I-beams; narrow flange I-beams, I-range; dimensions, weights, permissible variations, static values	Forgings
DIN 1025 Part 2	Steel sections, hot rolled I-beams; wide flange I-beams, IPB and IB range; dimensions, weights, permissible variations, static values	DIN 2519 Steel flanges; technical conditions of delivery
DIN 1025 Part 3	Steel sections; hot rolled I-beams; wide flange I-beams, lightweight type, IPBI-range; dimensions, weights, permissible variations, static values	DIN 7526 Steel forgings; tolerances and permissible variations for drop forgings
DIN 1025 Part 4	Steel sections; hot rolled I-beams; wide flange I-beams, heavy type, IPBv-range; dimensions, weights, permissible variations, static values	DIN 7526 Supplement Steel forgings; tolerances and permissible variations for drop forgings, examples for application
DIN 1025 Part 5	Steel sections; hot rolled I-beams; medium flange I-beams, IPE range; dimensions, weights, permissible variations, static values	DIN 7527 Part 1 Steel forgings; machining allowances and permissible variations for open-die forged discs
DIN 1026	Steel bars; steel sections; hot rolled round edge channels; dimensions, weights, static values	DIN 7527 Part 2 Steel forgings; machining allowances and permissible variations for open-die forged pierced discs
DIN 1027	Steel bars; hot rolled round edge zeds; dimensions, weights, permissible variations, static values	DIN 7527 Part 3 Steel forgings; machining allowances and permissible variations for seamless open-die forged rings
DIN 1028	Steel bars; hot rolled round edge equal angles; dimensions, weights, permissible variations, static values	DIN 7527 Part 4 Steel forgings; machining allowances and permissible variations for seamless open-die forged bushes
DIN 1029	Steel sections; hot rolled, round edge unequal angles; dimensions, weights, permissible deviations, static values	DIN 7527 Part 6 Steel forgings; machining allowances and permissible variations for open-die forged bars
DIN 1542	Steel plate 3 to 4.75 mm thick (medium plate); thicknesses, sizes, dimension and weight variations	
DIN 1543	(Subsequent edition in draft form) Flat steel products; hot rolled sheet and plate from 3 to 150 mm thick; permissible deviations on dimension, weight and form	
DIN 1581	Steel bars; hinge strip profiles; dimensions, weights	
DIN 59 051	Steel bars; hot rolled square edge T-bars with parallel flanges and webs (TPS steel); dimensions, weights, permissible variations	
DIN 59 110	Steel wire rod; dimensions, permissible variations, weights	
DIN 59 130	Steel bars; hot rolled round steel for bolts and rivets; dimensions, permissible deviations on dimension and form	
DIN 59 200	Flat steel products; hot rolled wide flats; dimensions, permissible variations on dimensions, form and weight	
DIN 59 410	Hollow sections for structural steel engineering; hot formed square and rectangular steel tubes; dimensions, weights, permissible deviations, static values	
		References to Standards and similar publications for steels with adjacent fields of application
		DIN 488 Part 1 Reinforcing steel; definitions, properties, identification symbols
		DIN 5512 Part 1 Materials for rail vehicles; general structural steels
		DIN 17 111 Low-carbon unalloyed steels for bolts, nuts and rivets; quality specifications
		DIN 17 115 Steels for welded round link chains; quality specifications
		DIN 17 135 Non-aging steels; quality specifications
		DIN 17 140 Wire rod produced from ordinary steels and unalloyed quality steels; quality specifications
		DIN 17 155 Part 1 Boiler plates; technical conditions of delivery
		DIN 17 155 Part 2 Boiler plates; quality specifications for the steels used
		DIN 17 200 Quenched and tempered steels; quality specifications
		DIN 17 210 Case hardening steels; quality specifications
		DIN 21 544 Steels for mining support sections; quality specifications
		Stahl-Eisen-Werkstoffblätter (Steel-iron data sheets) ¹⁾
		087 Weathering structural steels
		089 Weldable fine grained structural steels; quality specifications
		092 Hot rolled fine grained steels for cold forming; quality specifications

¹⁾ See page 2

Explanations

Developments in recent years in the field of manufacturing processes for steel and steel products and the revision of regional and international Standards for steels for general structural purposes made it necessary to revise the September 1966 edition of DIN 17 100. The negotiations on the present subsequent edition were conducted in a working committee composed, in equal numbers, of representatives of the steel producers, steel processors and steel users, and extended over a period of almost three years. The questions discussed in particular detail, the most important changes from the September 1966 edition of the DIN Standard and the differences from the regional and international Standards are summarized below. In the case of the conditions of delivery mentioned at the end it concerns

Euronorm 25 Steels for general structural purposes; quality specifications (issued by the European Coal and Steel Community; current edition November 1972)

and the international Standards drawn up in ISO/TC 17 – steel

ISO 630 Steels for general structural purposes (at present in draft form, February 1978) and

ISO 1052 General machinery steels (at present 3rd Recommendation September 1977, document ISO – 17/3 N 307).

1 Scope and lay-out of the Standard

The new edition of DIN 17 100 applies, like all the earlier versions of the Standard, to all the products named in Section 1.1 which are supplied in the hot-formed or normalized after finishing condition. The scope was extended to seamless and welded square and rectangular hollow sections.

When the Standard is next revised the proposal deferred on this occasion must be examined, whether the Standard should be sub-divided into several parts, each applying only to single groups of products, in order to achieve a better overall view of the stipulations.

2 Designation of the steels

a) The suggestion put forward for discussion, with the draft of October 1977 for the subsequent edition of DIN 17 100, to change the code numbers of the steels, i. e. to convert the identification number of the minimum value of the tensile strength into N/mm² (instead of kg/mm²), did not receive a majority in the concluding discussions. Accordingly, the code numbers were taken over basically unchanged from the September 1966 version of the Standard. The decisive point for this resolution, supported mainly by the users, was that no final decision was taken in the ISO Committee (TC 17/SC 2) on the standardized system of designation of steels to be used world-wide in future, so that if the need should arise, a later re-modification of the code numbers in DIN 17 100 might have become necessary or might be required in Euronorm 25 and in ISO-Standards 630 and 1052 (see Table 8).

b) In the case of a series of steels, the material numbers were changed from that used in the edition of September 1966 of DIN 17 100. These changes took place on the basis of the new classification of grades, carried out in the revision of Euronorm 20, into base steels, high-grade and special high-grade steels, and had already been announced in DIN-Normenheft 3 (DIN Standards Book 3) (6th edition 1976) and in the Stahl-Eisen-List (Steel-Iron List).

3 Classification of the steel grades

The number of steel grades (basic grades) was reduced from 24 to 11.

Since basic converter steel is no longer produced in Germany all steels in quality group 1 were deleted. In the context of the data given in the Tables, therefore, only quality groups 2 and 3 remained which differ in terms of the values for the chemical composition and notched-bar impact work and in the type of deoxidation as hitherto.

Strength class St 34, which can scarcely be regarded as a steel for general structural purposes with the range of application relevant to the other grades, was no longer taken into account in DIN 17 100, as in the international Standards.

In addition the introduction of the new strength class St 44 is in accordance with the international agreements. It replaces the former grades St 42, to which it is superior because of the lower maximum values for carbon content, and St 46, which in the past had not attained any practical importance.

In addition to steels USt 37-2 and RSt 37-2, grade St 37-2, which was already covered in the October 1957 edition of DIN 17 100, was again included without stipulated type of deoxidation. It can and should be ordered if the user attaches no importance to the delivery of a material of this strength class with fixed deoxidation type.

In the following Table 8 the steel grades contained in the present new edition of DIN 17 100 are compared with the comparable grades according to Euronorm 25 and according to the new versions of ISO Standards 630 and 1052 which can be regarded as practically passed.

Table 8. Comparison of steel grades according to DIN 17 100 with the steels for general structural purposes covered in the Euronorm and in the ISO Standards

Steel grade according to DIN 17 100	Comparable steel grade according to		
	Euronorm 25 ¹⁾	ISO 630 ²⁾	ISO 1052 ³⁾
St 33	Fe 310-0	Fe 310-0	—
(St 37-1 ⁴⁾	Fe 360-A	Fe 360-A	—
St 37-2	—	Fe 360-B ⁵⁾	—
USt 37-2	Fe 360-BFU	Fe 360-B	—
RSt 37-2	Fe 360-BFN	Fe 360-B ⁵⁾	—
St 37-3 U	Fe 360-C	Fe 360-C	—
St 37-3 N	Fe 360-D	Fe 360-D	—
—	Fe 430-A	Fe 430-A	—
St 44-2	Fe 430-B	Fe 430-B	—
St 44-3 U	Fe 430-C	Fe 430-C	—
St 44-3 N	Fe 430-D	Fe 430-D	—
—	Fe 510-B	Fe 510-B	—
St 52-3 U	Fe 510-C	Fe 510-C	—
St 52-3 N	Fe 510-D	Fe 510-D	—
(St 50-1 ⁴⁾	Fe 490-1	—	—
St 50-2	Fe 490-2	—	Fe 490-2
(St 60-1 ⁴⁾	Fe 590-1	—	—
St 60-2	Fe 590-2	—	Fe 590-2
St 70-2	Fe 690-2	—	Fe 690-2

¹⁾ November 1972 edition

²⁾ Current ISO Draft (ISO/DIS) February 1978

³⁾ New version of ISO/R 1052 – 1969, current document 17/3 N 307 of September 1977

⁴⁾ No longer covered in the present edition of DIN 17 100

⁵⁾ The type of deoxidation can be agreed at the time of ordering

Table 3 gives a survey of the steel grades with special service properties (see also Section 8.4.3).

By comparison with the September 1966 edition of the DIN-Standard, this edition also contains the grades which are suitable for rolled section shaping and for the manufacture of cold forming hollow sections with their own code letter (K) and their own material number.

4 Properties of the steels

a) Chemical composition

Starting from the proposals of the steel manufacturers, an extensive adjustment of the stipulations on chemical composition (see Table 1) to the corresponding values of Euronorm 25 was carried out in the draft of October 1977 for the new version of DIN 17 100. Some of the modifications associated with this were disputed in the concluding discussions. The users objected mainly to the planned raising, for steel RSt 37-2, of the maximum value for the carbon content to 0.20 % (ladle analysis) in the case of product thicknesses over 30 mm, which in their view meant a restriction of the suitability for welding. The manufacturers emphasized that with the basic oxygen steelmaking process, which is the most commonly used in steelmaking today, because of the low content of accompanying elements high carbon contents are provided for or, — thereby increasing production costs — additions of manganese should be made in order to achieve the required mechanical properties. Finally the limiting thickness of 40 mm was agreed, above which a maximum value of 0.20 % C is permissible; in Euronorm 25 this limiting thickness is 16 mm.

The other most notable alterations are the lowering of the maximum values for the phosphorous and sulphur content in each case to 0.040 % for steels of quality group 3 and the raising of the nitrogen content to 0.009 % for the killed steels of quality group 2. The differences between the permissible maximum values for the ladle analysis and the sample analysis which were stipulated in the September 1966 edition of the Standard even after the experiences with ingot weights up to 6 tonnes, had to be partly enlarged because of the larger ingot weights common today.

Lengthy discussions arose from the proposal, made by some representatives of the users and the testing institutions, to define more precisely the additions of nitrogen — fixing elements in the case of the steels of quality group 3 depending on type, or to limit their level, in order to ensure that the suitability for welding — for instance in the supply of degraded fine-grained steels for structural purposes with a higher yield point — is not impaired. In this connection it was agreed to define the steels for general structural purposes according to DIN 17 100 as unalloyed steels in the meaning of Euronorm 20 (see Sections 3 and 8.3.1). The representatives of the steel producers declared that more far-reaching stipulations were on the one hand not possible, for manufacturing technical and economic reasons, but on the other hand not necessary, since with the limits set by Euronorm 20 for the chemical composition it could be assumed that the suitability for welding would not be impaired.

b) Mechanical and technological properties

The values for the mechanical and technological properties in Table 2 were converted to the international system of units (SI), i. e. to N/mm² (instead

of kg/mm²) for the tensile strength and the yield point and also to J (instead of kgm/cm²) for the notched-bar impact work. According to the worldwide standardized rules agreed in ISO/TC 17, the conversion of kg to N took place by multiplication with the factor 9.81 and rounding up of the values to the nearest final figure 0 for the tensile strength and to the nearest final figures 0 or 5 for the yield point. The figures for the notched-bar impact work in the case of DVM or aged DVMF specimens were deleted, the values in Table 2 now relate only to the internationally customary V-notch specimen with the special rule according to Section 8.4.1.4 for specimens from products with a thickness of less than 10 mm.

The most significant change compared with the previous stipulations is the more extensive graduation of the minimum values for the yield point with the product thickness taken over from Euronorm 25. It leads, by comparison with the 1966 edition of the Standard, to a lowering of the values for grades St 37, USt 37-2, St 50-2, St 60-2 and St 70-2 in thicknesses above 63 mm. The users regarded this as a significant restriction of the range of application of the steels and suggested that constant values for the thickness range 40 to 100 mm should be given as before. The steelmakers emphasized that the dependence of the yield point on thickness in the case of steels of constant chemical composition was due to technical factors and the new graduation of the values was objectively more accurate than the previous rule. The values demanded by the users could be achieved only with the addition of alloying elements such as manganese. The steps, however, led basically to a change in the steel grades and to an increase in manufacturing costs.

Finally, in the present new edition the stipulations of Euronorm 25 were included except in the case of products of steels RSt 37-2 and St 37-3, for which the previous graduation of the yield point values as a function of thickness was retained.

c) Suitability for welding

After long discussions the figures relating to the suitability of the steels for welding (see Section 8.4.2) were in principle adapted to the stipulations in the September 1966 edition of the Standard (Section 7.4.3 in that edition). Suggestions for an extension of the stipulations by notes on the possible influence of alloying elements present, and thus in certain circumstances special steps which might become necessary when welding, were initially disregarded, because such data cannot clearly describe the subject with the brevity required in quality Standards and tend to lead to the creation of uncertainty amongst users. In this connection, however, it was agreed to deal with the whole problem — area again during the revision of DIN 8528 Part 2 which will in any case be rendered necessary by the new version of DIN 17 100. The discussions are to be conducted in a joint committee of the Normenausschuss Eisen und Stahl (Standards Committee Iron and Steel) and the Normenausschuss Schweisstechnik (Standards Committee Welding Technology). At the same time a decision will have to be made whether DIN 8528 Part 2 should be transformed into a supplement to DIN 17 100.

5 Other subject matter in the Standard

- a) The other contents of this new version of DIN 17 100 were essentially in line with the stipulations of the earlier September 1966 edition. Changes or additions in the lay-out took place on the basis of the guidelines laid down in DIN 820. In addition an attempt was made to give a better overall view of the applicable properties by extending Tables 1 and 2.
- b) The stipulations in Section 11 on the admissibility and settling of complaints were initially unchanged. However discussions are taking place at this time on this problem-area in the context of the negotiations on the first edition of DIN 17 010 General technical conditions of delivery for steel and steel products (at present Draft 08. 1978), the results of which are to be taken into account as an integral part of all

DIN Standards handled by the Iron and Steel Committee (FES). After the passing of DIN 17 010 the stipulations made therein will thus in any case apply also to DIN 17 100.

- c) Attention is also drawn to the fact that in the Standard reference is no longer made to "guaranteed" properties. In accordance with the recommendations of the DIN Deutsches Institut für Normung e. V. (German Institute for Standardization) the term "guarantee" should be avoided for legal reasons in all DIN Standards on account of the possibility of consequential legal liability arising from the guaranteeing of properties. The steelmakers emphasized that in their view this would change nothing in the technical indicative value of DIN Standards.