

## ANSI Steel Hubs for Split Taper Bushings

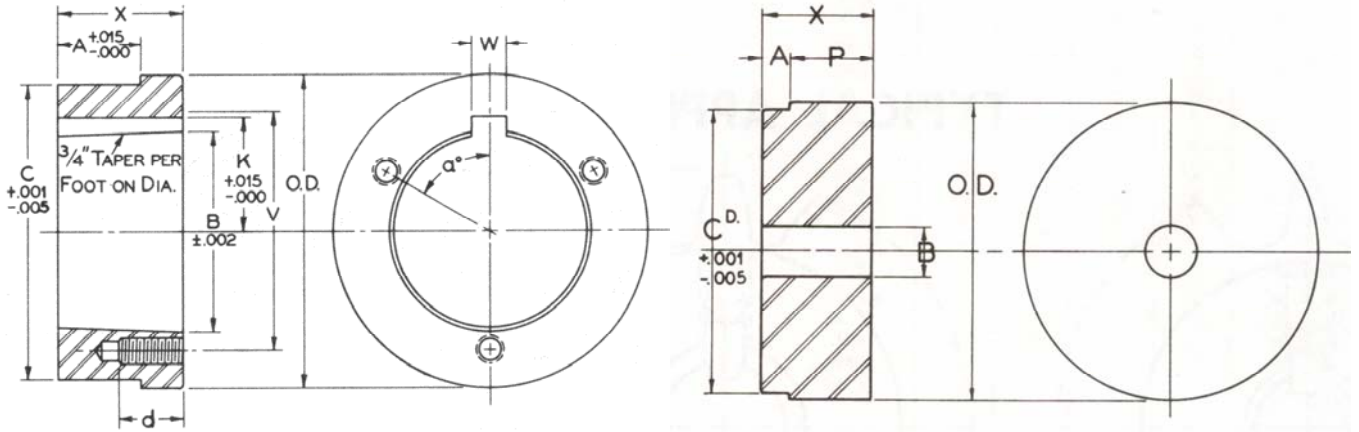

Steel Hubs for Split Taper Bushings

Type "B" Steel Hubs

### Steel Hubs for Split Taper Bushings

Part No.	For Bushing	Dimensions									Tapped Holes		Wt. Lbs.	
		O.D.	A	B	C	K	V	W	X	a	d	No.		Size
HG1	G	2"	0.174"	1.168	1.875"	-	1 9/16"	-	5/8"	-	5/8"	2	1/4-20	0.4
HH1	H	2 1/2	0.174	1.621	2.375	-	2	-	7/8	-	7/8	2	1/4-20	0.6
HCH1	H	2 1/2	0.625	1.621	2.375	-	2	-	7/8	-	7/8	2	1/4-20	0.7
HP1	P1	3	0.292	1.9375	2.875	1 3/32"	2 7/16	3/8"	1 5/16	60°	5/8	3	5/16-18	1.4
HCP1	P1	3	1.000	1.9375	2.875	1 3/32	2 7/16	3/8	1 5/16	60	5/8	3	5/16-18	1.1
HP2	P2	3	1.100	1.9375	2.875	1 3/32	2 7/16	3/8	2 5/16	60	5/8	3	5/16-18	2.5
HB1	B	3 7/8	0.292	2.623	3.750	1 7/16	3 1/8	1/2	1 5/16	60	13/16	3	5/16-18	2.3
HB2	B	4 1/2	0.709	2.623	4.375	1 7/16	3 1/8	1/2	1 3/4	60	13/16	3	5/16-18	4.7
HQ1	Q1	4 1/2	0.709	2.875	4.375	1 9/16	3 3/8	1/2	1 3/4	60	7/8	3	3/8-16	4.4
HQC1	Q1	4 1/2	1.250	2.875	4.375	1 9/16	3 3/8	1/2	1 3/4	60	7/8	3	3/8-16	4.4
HQ2	Q2	4 1/2	1.606	2.875	4.375	1 9/16	3 3/8	1/2	2 3/4	60	7/8	3	3/8-16	6.9
HR1	R1	5 3/4	0.709	4.000	5.625	2 3/16	4 5/8	3/4	2	60	1 1/8	3	3/8-16	7.3
HR2	R2	5 3/4	1.606	4.000	5.625	2 3/16	4 5/8	3/4	4	60	1 1/8	3	3/8-16	15.4
HS1	S1	6 3/4	0.946	4.625	6.500	2 9/16	5 3/8	3/4	3 5/16	60	1 5/8	3	1/2-13	17.3
HS2	S2	6 3/4	2.963	4.625	6.500	2 9/16	5 3/8	3/4	5 11/16	60	1 5/8	3	1/2-13	30.4
HU0	U0	8 1/2	2.000	6.000	8.250	3 1/4	7	1 1/4	3 3/4	60	2	3	5/8-11	32.0
HU1	U1	8 1/2	2.963	6.000	8.250	3 1/4	7	1 1/4	5 5/8	60	1 3/4	3	5/8-11	44.6
HU2	U2	8 1/2	6.016	6.000	8.250	3 1/4	7	1 1/4	8 5/8	60	1 3/4	3	5/8-11	69.0
HW1	W1	12 1/2	2.963	8.500	12.250	4 9/16	10	1 1/4	6 3/8	22 1/2	1 3/4	4	3/4-10	130.0

### Type "B" Steel Hubs

Part No.	Dimensions					Bore		Wt. Lbs.
	O.D.	A	C	P	X	Stock	Max.	
HB40	3"	0.281"	2.875"	27/32"	1 1/8"	1/2"	1 7/8"	2.3
HB50	3 1/4	0.344	3.125	1 1/32	1 3/8	5/8	2 1/4	3.0
HB60	4	0.469	3.875	1 1/32	1 1/2	5/8	2 3/8	5.0
HB80	5	0.563	4.875	1 1/2	2 1/16	3/4	3	11.1
HB100	5 1/4	0.688	5.125	2 1/16	2 3/4	1	3 1/4	16.3

NOTE-"A" dimension is plate thickness of sprocket for chain indicated in part number. Other plates can be used by remachining "A" dimension.