

Intelligent Motor Protection Relay MDB-501



We Are The FACTORY in Control & Protection Relays

Focus on Motor Protection • Quickly Solve Your Troubles

The NEW MDB-501Z is a modular motor protection relay that provides integrated protection, metering and data logging functions for three-phase motors used in industrial environments.. The relay provides 10 protective functions by utilizing both current and voltage inputs. Current transformers are not required for currents up to 160 A.

Next Generation Relay with Communication Functionality for Motor Monitoring, Protection and Control

- Easy installation and maintenance for improved work efficiency
- Save time and maintenance cost
- Improve the efficiency and safety of production process
- In unmanned management system, save energy through operation statistics

> Application

Buildings

- Office, commercial, and residential buildings, schools, hospitals

Industrial Facilities

- Petrochemical, electronic, glass, steel, semiconductor, chemical, pharmaceutical, cement, paint, etc.

Devices

- Pumps, Fans, Refrigeration Units, Blowers, Motors, Compressors, Lifts, Elevators, Cranes, Mining excavators and conveyors

by Ginri Power Automation Co., Ltd.

Intelligent Motor Protection Relay

MDB-501

V2.1



■ Features

- Compact modular size
- Built-in LCD and keypad afford a precise, digital setting
- Three-phase monitoring of short-circuit, locked-rotor, overcurrent, undercurrent, phase loss, phase unbalance, overload alarm
- 1 or 2 phase monitoring of overvoltage, undervoltage
- Earth fault (should couple with ZCT)
- RS-485 communication port
- DC4-20 mA analog output
- Separated output contacts, two for trip, one for alarm
- 4 LEDs for status indication
- Fault recording with last 3 faults

□ Function Data

Functions	Condition & Setting range	Delay time
Overcurrent (I>, definite)	Condition : load current exceeds setting threshold. Setting range: 0.3-16A, 3-160A, 10-999A.	0.5-60s
Overcurrent (I>, inverse)	Condition : load current exceeds setting threshold. Setting range: 0.3-16A, 3-160A, 10-999A.	class 1-5 see TCC
Undercurrent (I<)	Condition : load current less than setting threshold. Setting range same as overcurrent, and the value must be less than overcurrent.	0.5-60s
Phase loss (PL)	current unbalance exceeds 50%.	0.5-60s
Current unbalance (ASYM)	current unbalance exceeds setting threshold. Setting range: 10-50%. *Unbalance factor (%) = (Imax phase - Iaverage) / Iaverage x 100%	0.5-60s
Start-up delay (dt)	When motor is starting, LCD will show a countdown. Overcurrent, undercurrent, lock-rotor, current unbalance are blocked during the start-up.	0-200s
Lock-rotor (JAM)	Load current exceeds setting threshold. Active only in motor running. Setting range: 1.5-8 times of setting overcurrent.	0.5-60s
Short circuit (SC)	Load current exceeds setting threshold. Setting range: 3-22 times of setting overcurrent.	≤50ms
Ground fault (GF)	Earth leakage current exceeds setting threshold. Setting range: 30mA-2.5A. Should couple with a ZCT with CT ratio 5A/10mA.	0.5-60s
Overvoltage (U>)	Power voltage exceeds setting threshold. Setting range: 65-690V, hysteresis 5%.	0.5-60s
Undervoltage (U<)	Power voltage less than setting threshold. Setting range: 65-600V, hysteresis 5%.	0.5-60s
Overload Alarm (OL Alarm)	Load current exceeds setting threshold. Setting range: 20-100% of setting overcurrent. Autoreset immediately when fault condition is removed.	1s

□ Technical data

Model	MDB-501Z	MDB-501F
Structure	Integrative	Separate
Mounting	Panel mounting	Flush mounting
Measurement error	1%	
Rated supply voltage	AC220V, AC380V, 50/60Hz	
Current setting	0.3-16A, 3-160A, 10-999A	
Time-current characteristic	Definite & inverse selectable	
Reset mode	Manual / Auto / power cycle	
Communication	Modbus RTU/RS-485	
Output type	Trip: 1NO+1NC, Alarm: 1NO	
Contact capacity	5A 250VAC, 3A 380VAC	
Power consumption	≤5VA	
Weight	600g	
Dimensions for MDB-501Z	90 x 70 x 106.5mm (H x W x D)	
Mounting hoze size for MDB-501F	90 x 46 mm (H x W)	

□ Ordering Information

MDB - 501 Z / 0.3-16A , AC220V

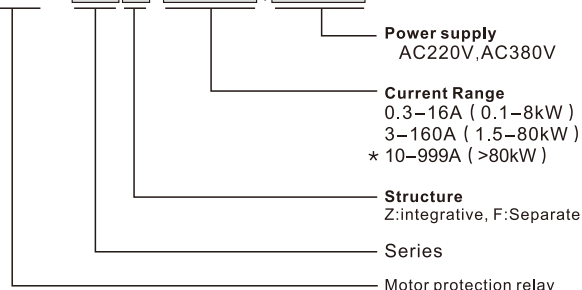

- * For 10-999A type, the relay should couple with external CT.
- * ZCT for ground fault is optional, it should be purchased separately.
- * The connecting cable for MDB-501F is 1.5 meters by default.

□ Inverse time-current characteristic curve (TCC)

trip class	0 (definite time)	1 (class 5)	2 (class 10A)	3 (class 10)	4 (class 20)	5 (class 30)
* In/Is						
< 1.1	5s	not trip				
1.2		63	125	250	500	750
1.5		40	80	160	320	480
2.0		22	45	90	180	270
5.0		36	7.2	14	29	43
6.0		2.5	5	10	20	30
7.2		1.8	3.5	6.9	14	21

- * In-load current, Is-setting overcurrent

□ Front Panel View

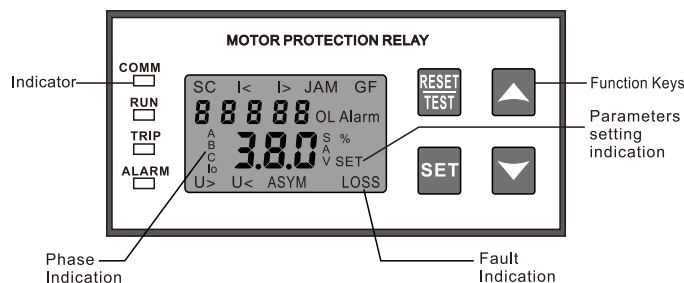

□ Function keys

RESET TEST	Manual reset when the relay is tripped. Long press to self test trip.
SET	Press to query parameters. Long press to set parameters.
Up Arrow / Down Arrow	Change setting value in setting mode. Long press to change quickly. Shift showing current and voltage when motor running

□ Current and voltage display

3 phase currents are displayed every 2 seconds in sequence. Press “ \approx ” “ \approx ” keys to shift showing 3 phase current, leakage current, power voltage.

Intelligent Motor Protection Relay

MDB-501

V2.1

Parameters setting guide

Setting mode is only available in standby status. Long press "SET" for 3s, It will get into parameter setting mode. "SET" LCD will light on. Press "SET" to shift to next parameter, press "▲" or "▼" to set up the values. Long press could accelerate increase or decrease. Press "RESET/TEST" to exit setting. The relay will quit automatically if no operation for 30s.

Display	Parameters	Setting range	Default	Note
	overcurrent threshold	0.3-16A 3-160A 10-999A	5A 20A 100A	
	inverse trip class	0-5	0	0 for definite
	definite delay time of overcurrent	0.5-60.0s	5s	active when trip class is 0
	undercurrent threshold	OFF, 0.3-16A OFF, 3-160A OFF, 10-999A	OFF	OFF for disable
	delay time of undercurrent	0.5-60.0s	5s	
	undercurrent output mode	AL, OL	AL	see below
	start-up delay time	0-200s	5s	LCD shows a countdown
	lock-rotor threshold	OFF, 1.5-8	5	multiples of overcurrent, OFF for disable
	delay time of lock-rotor	0.5-60.0s	3s	
	short circuit threshold	OFF, 3-22	10	multiples of overcurrent, OFF for disable
	current unbalance threshold	OFF, 10-50%	20%	OFF for disable
	delay time of unbalance	0.5-60.0s	5s	
	current unbalance output mode	AL, OL	AL	see below
	delay time of phase loss	OFF, 0.5-60.0s	2s	OFF for disable
	ground fault threshold	65-690V, OFF	OFF	OFF for disable
	delay time of ground fault	0.5-60.0s	1s	

OL & AL OUTPUT mode

OL OUTPUT means when faults occur, trip LED will on, trip contacts (OL) and alarm contact (AL) will all trip.

AL OUTPUT means when faults occur, alarm LED will on, only alarm contact (AL) will trip. Alarm contact will auto reset when fault condition is removed.

Overcurrent, lock-rotor, short circuit, phase loss are OL OUTPUT unchangeable.

Undercurrent, unbalance, ground fault, overvoltage, undervoltage could be set to OL or AL OUTPUT optionally.

Display	Parameters	Setting range	Default	Note
	ground fault output mode	AL, OL	AL	see below
	overvoltage threshold	OFF, 65-600V	OFF	OFF for disable
	delay time of overvoltage	0.5-60.0s	5s	
	overvoltage output mode	AL, OL	AL	see below
	undervoltage threshold	OFF, 0.03-2.5A	OFF	OFF for disable
	delay time of undervoltage	0.5-60.0s	5s	
	undervoltage output mode	AL, OL	AL	see below
	CT ratio	20-200	20	valid for 10-999A type, 20 means 100/5
	auto-reset time	OFF, 0.1-30 minutes	10min	OFF for manual reset see below
	limit of auto-reset in 30 minutes	OFF, 1-10	3	OFF for unlimited see below
	overload alarm threshold	OFF, 20-100%	OFF	AL output only, see below
	communication address	1-247	1	
	4-20mA channel	A, b, c	A	see below
	single phase mode	ON, OFF	OFF	phase loss and current unbalance will be disabled
	restore to defaults	YES, NO	NO	
	version			
	exit	exit setting mode		

4-20mA analog output

4-20mA Output could correspond to any phase current of A, B, C. 20mA full range correspond to 2 times of setting overcurrent. The formula is: $I_{mA} = (I_n / 2I_s) * 16 + 4$

Auto-reset

Auto reset is invalid for phase loss, stall, and short circuit. To prevent the motor from frequently starting, there is a limit of auto reset in 30 minutes. The count will be cleared by manual reset when the count reaches the limitation.



Ginri Power Automation Co., Ltd.

No.337, Kaichuang Road, Baitawang Industrial District,
Beibaixiang Town, Yueqing City, Zhejiang Province, China

Tel: +86-577-57198185
E-mail: info@ginri.com

Fax: +86-577-62982268
http://www.ginri.com

Intelligent Motor Protection Relay

MDB-501

V2.1

□ Fault indication

When the relay is tripped. The cause and current of the trip is displayed and latched until the relay is reset.

Indication	Description	Indication	Description
SC	Short circuit fault indication	U>	Overvoltage fault indication
I<	Undercurrent fault indication	U<	Undervoltage fault indication
I>	Overcurrent fault indication	ASYM	Current unbalance fault indication
JAM	Lock-rotor fault indication	LOSS	Phase loss fault indication
GF	Ground fault indication	OL Alarm	Overload alarm indication

□ Fault history check

Pressing "◀" more than 3sec, it displays the latest fault cause and the fault voltage. Press "SET" to check later fault continually. Press "↔" or "▶" to shift the display of current and voltage. The relay will exit automatically after Log3. The oldest fault record is over written when the number of fault to record exceeds three. The relay will quit automatically if no operation for 30s.

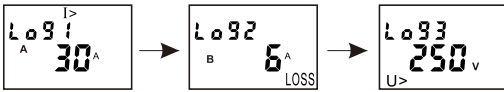

□ Self test trip

This function is disable when the motor is starting or running. Pressing "RESET/TEST" key more than 3s to active self test trip mode, all the output contacts will trip when 3s expires. The display shows "RESET/TEST" and countdown, when the test is done, the display shows "End". By pressing "RESET/TEST" to reset. Before 3s expires, pressing "RESET/TEST" blocks the test trip and return to the voltage display. The relay will quit self test trip mode and reset if no operation for 30s.



□ Wiring Diagram

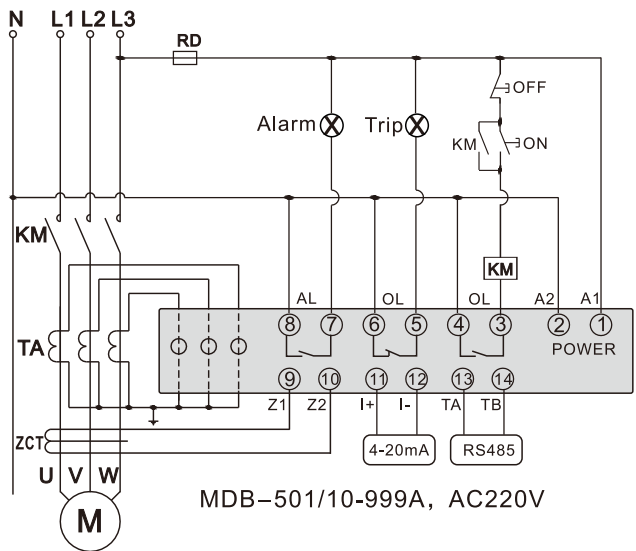
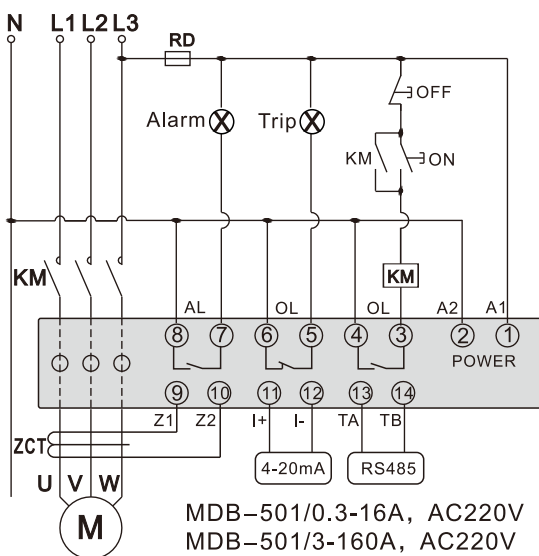

I/O Terminal layout

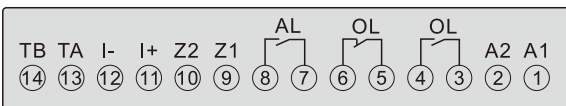

NOTE:

1. ALL the contacts position shown in 'Power off' condition. For OL contacts, position is inverse when powered and under normal operation. For AL contact, the contact is closed when under fault operation.
2. OL is trip contact, AL is alarm contact. (See page 2 OL & AL OUTPUT mode for details.)
3. Z1-Z2 should couple with a ZCT with CT ratio 5A/10mA.
4. For 10-999A type, the relay should couple with external CT and set the CT ratio.

□ Dimensions(mm)

