

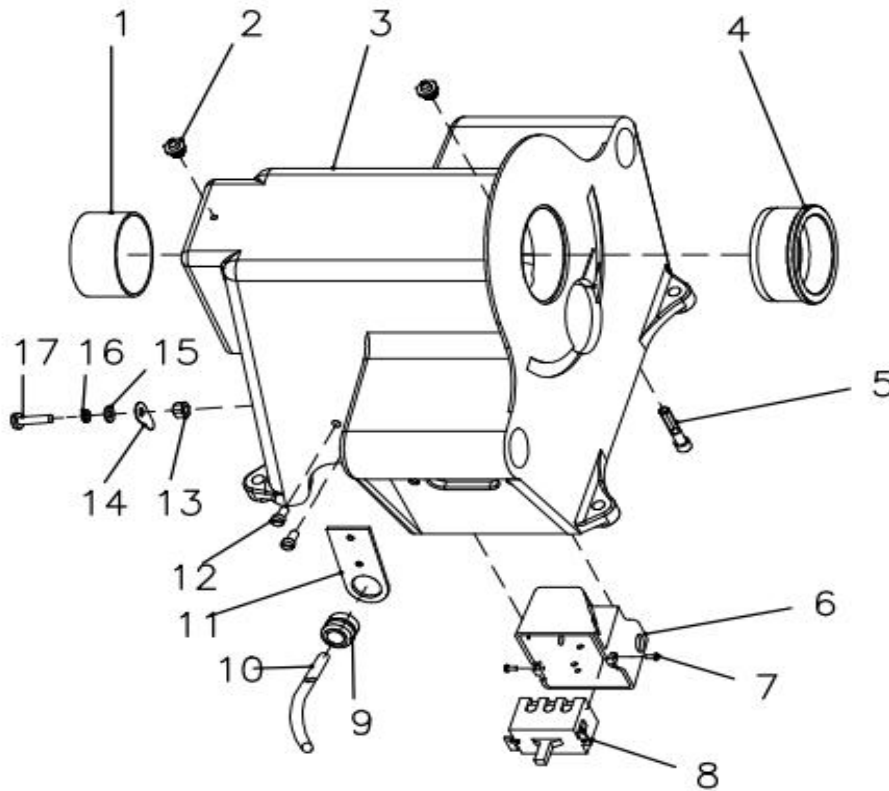

SQ50D 中英文爆炸图 (SQ50D spare parts list)

车头箱部件123 (37100) Main Components



S/N	Ref. No.	品名	Description
1	41501007	后复合轴承	Rear Bearing bronze
2	50804001	直通式压铸油杯 M6 (GB/T7930.1-1995)	Grease Fitting M6
3	30112098	机身 (精铸) (含 1, 2, 4, 9, 11)	Machine Body
4	41501008	前粉末冶金轴承	Front Bearing
5	50103159	内六角圆柱头螺钉 UNC5/16-18x45	Screw UNC5/16-18x45
6	41604001	开关盒	Switch Box
7	50103064	十字盘头螺钉 M4x10 (GB/T818-2000) (2)	Screw M4x10 (2)
8	30402005	拨动开关	For-Rev Switch
9	40403028	线卡	Cord Grommet
10	30402004	美式电源线 (4.5米)	Power cord (4.5M)
11	41404001	电线定位板	Strain Relief Plate
12	50103138	开槽盘头螺钉 UNC1/4-20x1/4 (2)	Screw UNC1/4-20x1/4 (2)
13	50102001	六角头螺母 M4 (GB/T6170-2000)	Nut M4
14	40802001	地线标志	Ground Sign
15	50107001	平垫圈 D=4 (GB/T97.3-2000)	Flat Washer D=4
16	50107016	标准弹性垫圈 D=4 (GB/T93-87)	Spring Washer D=4
17	50103066	十字槽盘头螺钉 M4x16 (GB/T818-2000)	Screw M4x16





车头轴部件 221 (37200) Drive Components

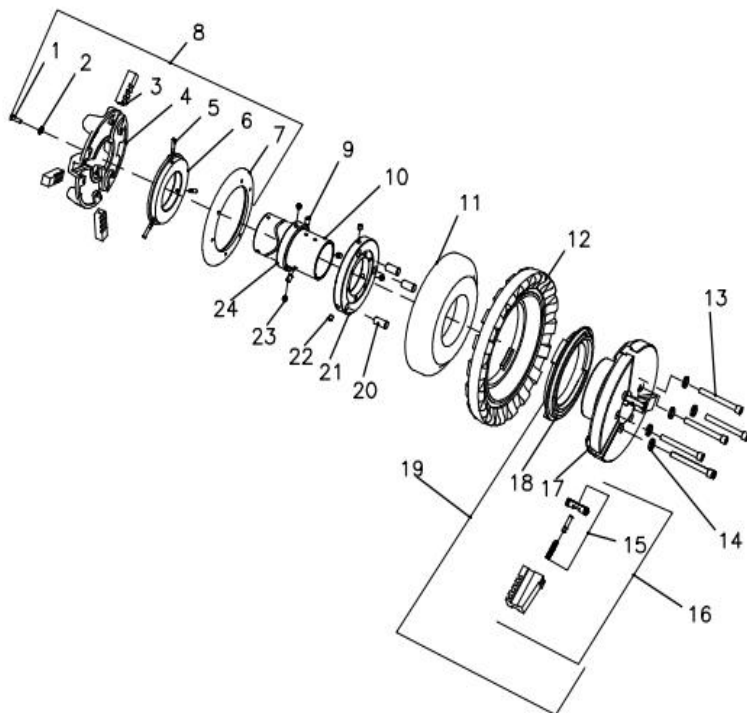

S/N	Ref. No.	品名	Description
1	50103139	开槽沉头螺钉 UNC12#-24x20 (6)	Screw UNC12#-24x20 (6)
2	50107037	锥形垫片D=6 (GB/T956-1) (6)	Lock Washer (6)
3	41802011	后卡爪 (3)	Rear Jaw (3)
4	40303081	后卡盘	Centering Head
5	40402005	小螺盘定位销 (3)	Step Pin
6	40303082	小螺盘	Rear scroll
7	40303024	小螺盘挡板	Back Plate
8	30109030	后卡盘总成	Rear Centering Assembly
9	50103188	内六角平端紧定螺钉 UNF5/16-24x1/4 (3)	Screw UNF5/16-24x1/4 (3)
10	41705017	轴筒	Drive Shaft
11	40201007	大内齿盘	Ring Gear
12	40303084	锤击盘	Hand Wheel
13	50103161	内六角圆柱头螺钉UNC5/16-18x2 3/4 (6)	Screw UNC5/16-18x2 3/4 (6)
14	50107019	弹性垫圈D=8 (GB/T93-87) (6)	Spring Washer D=8 (6)
15	30108022	卡爪尖总成 (3)	Jaw Insert Set (3)
16	30109029	前卡爪总成 (3)	Front chuck Jaw Set (3)
17	30109009	卡盘体	Cap
18	40303025	大螺盘	Front scroll
19	30109028	卡盘体组件	Cap Assembly
20	40402004	圆柱销 (3)	Drive Pin (3)
21	40303083	连接盘	Drive Ring
22	50103185	内六角圆柱端紧定螺钉 UNF5/16-24x1/2 (3)	Screw UNF5/16-24x1/2 (3)
23	50103178	内六角圆柱头紧定螺钉 UNC5/16-18x1/4 (2)	Screw UNC5/16-18x1/4 (2)
24	41502018	轴筒挡圈	Thrust Ring
25	30109031	轴筒挡圈组合件	Thrust Ring with 2 screws





滑架部件 227 (37800) Carriage

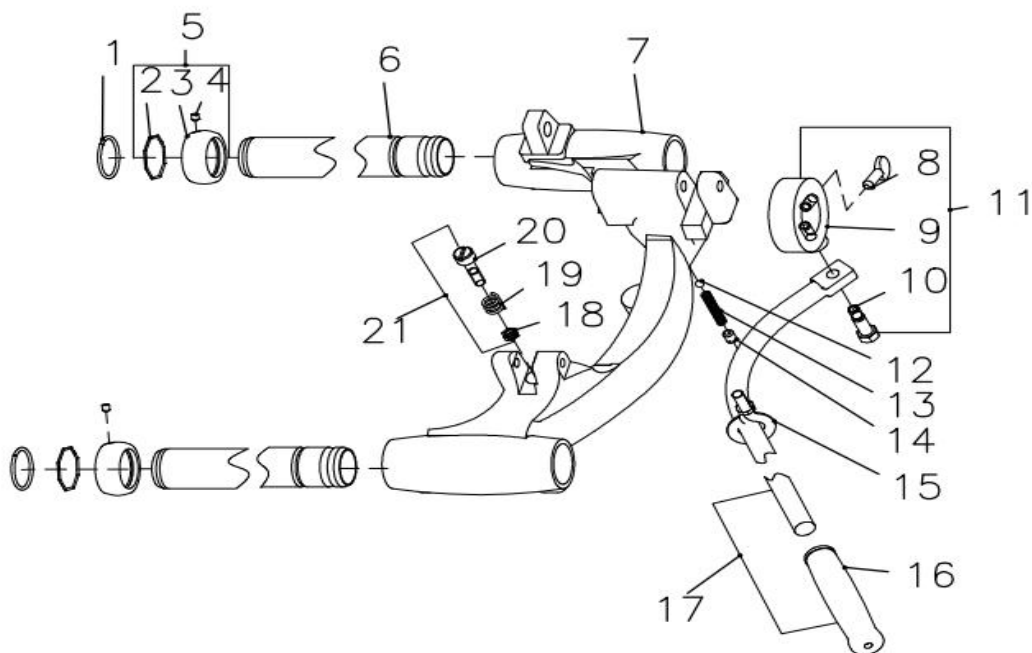

S/N	Ref. No.	品名	Description
1	41502021	轴用钢丝挡圈 (2)	Spring ring (2)
2	41502020	八角钢丝挡圈 (2)	Snap Ring (2)
3	41502022	挡圈 (2)	Check Ring (2)
4	50103174	内六角圆柱端紧定螺钉 UNF 1/4-28x1/4 (2)	Screw UNF 1/4-28x1/4 (2)
5	30108016	定位套总成 (2)	Ring Assembly (2)
6	41703009	导柱 (2) (含1号)	Support bar (2)
7	30109026	滑架总成 (7+21)	Carriage Assembly (7+21)
8	40401014	翼型螺钉	Thumb Screw
9	41502019	定位圈	Collar
10	40401015	定位螺钉	Shoulder bolt
11	30108017	定位圈总成	Collar Assembly (2)
12	50402004	钢球D=6 (GB/T308-84)	Detent assembly
13	50702005	压簧0.5x5x305	
14	50103187	内六角平端紧定螺钉 UNC5/16-18x1/4	
15	40401016	螺栓	Eye Bolt assembly
16	41902001	手柄套	Hand Grip
	30104006	手动杆总成 (17+15+11)	Lever Assembly
17	30104005	手柄组件	Lever arm
18	50102032	六角锁紧螺母 UNC5/16-18	Nut UNC5/16-18
			Adjusting Compression Spring
19	50702006	调整压簧2x14x16x45	2x14x16x45
20	50103169	调整螺丝 UNC5/16-18x18	Adjusting Screw UNC5/16-18x18
21	30108018	缓冲螺钉总成	Stop bolt assembly





变速箱部件 323 (37300) Gear Box Part

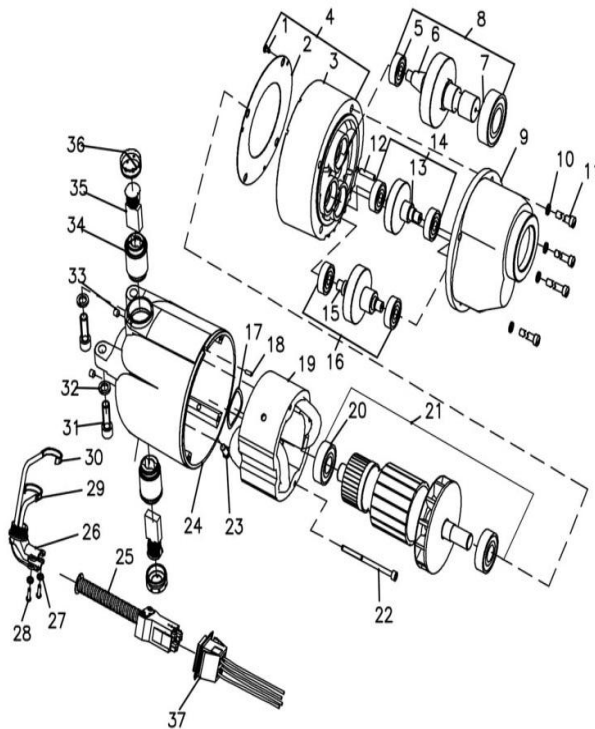

S/N	Ref. No.	品名	Description
1	50103144	十字槽盘头螺钉UNC6#-32x3/8 (3)	Screw UNC6#-32x3/8 (3)
4	30403038	电机端盖总成	Fan Housing Assembly
5	50401002	带密封圈深沟球轴承6200 (GB/T26-94)	Gear Bearing 6200
7	50401015	带密封圈深沟球轴承6205 (GB/T276-94)	Front Bearing 6205
8	30102022	驱动齿轮总成 (38转)	Drive Gear Assembly (38RPM)
	30102023	驱动齿轮总成 (57转)	Drive Gear Assembly (57RPM)
9	40302018	变速箱体	Gear Housing
10	50107043	标准弹性垫圈UNC1/4	Lock Washer UNC1/4
11	50103170	电机长螺钉UNC1/4-20x75 (4)	Screw UNC1/4-20x75 (4)
12	40402006	美制圆柱销	Dowel Pin
14	30102019	一级传动齿轴总成	1st Gear Assembly
16	30102020	二级传动齿轴总成 (38转)	2nd Gear Assembly (38RPM)
	30102021	二级传动齿轴总成 (57转)	2nd Gear Assembly (57RPM)
17	50107036	电机用铜质波形垫圈33.5x39.8x0.3 (GB/T7590-2005)	Loading Spring Washer 33.5x39.8x0.3
18	50105062	美制圆柱销3.15x9	Round Pin 3.15x9
19	30403026	定子总成 (110V)	Field (110V)
	30403030	定子总成 (220V)	Field (220V)
20	50401009	深沟球轴承6203 (GB/T26-1994) (2)	Armature Bearing 6203 (2)
	30403027	转子总成 (110V)	Armature (110V)
21	30403031	转子总成 (220V)	Armature (220V)
22	50103152	内六角圆柱头螺钉UNC10#-24x80 (2)	Mounting Screw UNC10#-24x80 (2)
23	50101026	六角头螺栓	Bolt
24	30402012	电机壳总成 (包括35, 36, 37, 38)	Motor Housing Assembly
25	30403044	专用插头	Plug
26	30403043	弯管接套	Connector 90 degree
27	50107028	外齿垫片D=5 (GB/T862.1-1987)	Spacer D=5
28	50103142	十字槽盘头螺钉UNC10#-24x16 (2)	Locking Screw UNC10#-24x16 (2)
29	30402009	红色刷架引线	Lower Lead Wire
30	30402010	白色刷架引线	Upper Lead Wire
31	50103166	内六角圆柱头螺钉UNC3/8-16x30 (2)	Screw UNC3/8-16x30 (2)
32	50107044	标准弹性垫圈UNC3/8 (2)	Spring Washer UNC3/8 (2)
33	50103182	内六角锥端紧定螺钉UNC1/4-20x1/4 (2)	Screw UNC1/4-20x1/4 (2)
34	30403033	碳刷架 (2)	Brush Holder Assembly (2)
35	30403034	碳刷 (2) (一付)	Carbon Brush Assembly (2)
36	41901032	碳刷盖 (2)	Carbon Brush Cup (2)
37	30402013	电机插座总成	Outlet Jumper Assembly
		电机总成 (220V)	Motor Assembly (220V)
		电机总成 (110V)	Motor Assembly (110V)
		SQ50D电机+齿轮箱总成38转 220V	
		SQ50D电机+齿轮箱总成38转 110V	
		SQ50D电机+齿轮箱总成57转 110V	





板牙头部件 425/811A (37400) Die head

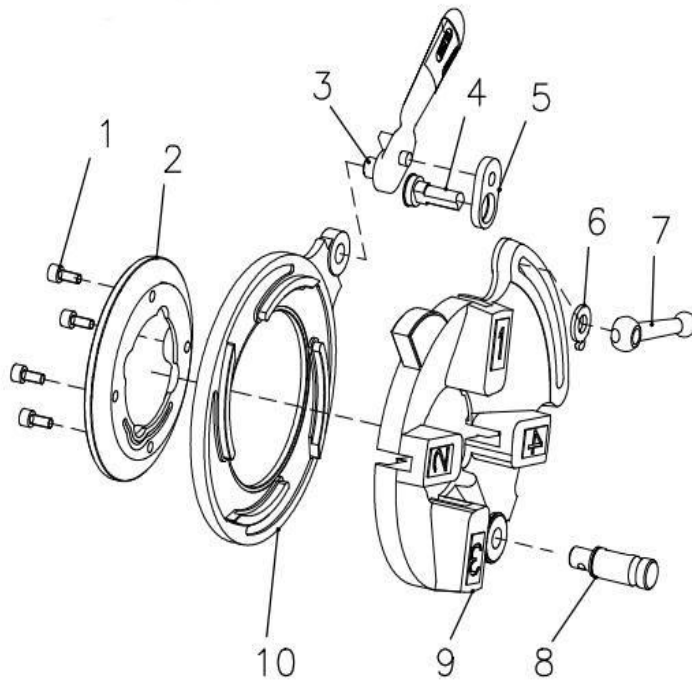

S/N	Ref. No.	品名	Description
1	50103153	内六角圆柱头螺钉UNC1/4-20x5/8	Screw UNC1/4-20x5/8
2	40303028	托盘	Retaining Ring
3	40901028	调整手柄	Throw-Out Lever
4	40401013	夹紧螺钉	Lock Screw
5	41802013	偏心块	Link
6	41001008	垫片	Lever Washer
7	40901027	锁紧手柄	Clamp Lever
8	30108019	支轴组件	Post Component
9	40303027	板牙盘 (包括8号) NPT	Head w/post
		板牙盘 (包括8号) BSPT	
10	40303026	曲线盘	Cam Plate
	10601010	板牙头总成 NPT	
	10601009	板牙头总成 BSPT	





刮刀部件 524 (37500) Reamer

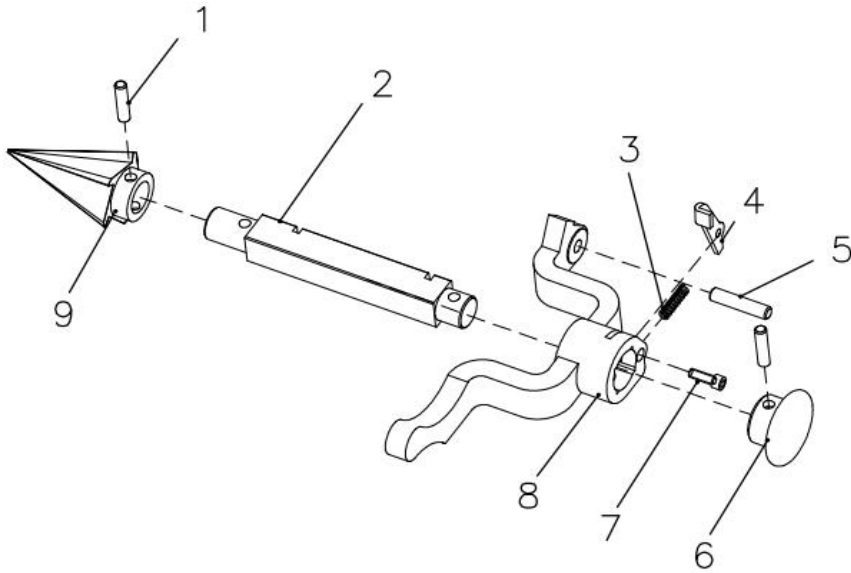

S/N	Ref. No.	品名	Description
1	40402007	直销 (2)	Pin (2)
2	41701007	拉杆	Reamer Bar
3	50702003	弹簧 1x6.5x3012.5	Latch Spring 1x6.5x3012.5
4	41001009	扳手	Reamer Latch
5	42001016	倒角架支轴	Hinge Pin
6	41801009	手柄	Reamer Knob
7	50103154	内六角圆柱头螺钉 UNC1/4-20x3/4	Screw UNC1/4-20x3/4
8	40304017	倒角架	Reamer Arm
9	40602006	五棱刮刀	Cone
	10701004	刮刀总成	Reamer complete





割刀部件 624 (37600) Cutter

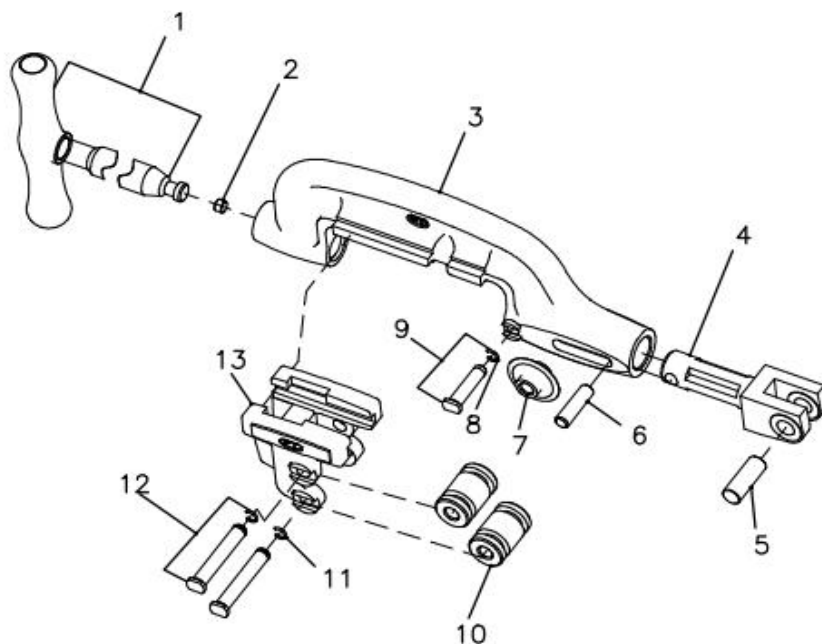

S/N	Ref. No.	品名	Description
1	30104004	手柄组件	Handle Component
2	41801010	顶柱	Support Pillar
3	40304019	割刀架	Cutter Frame
4	42001017	连接轴	Support Arm
5	40402009	支撑销	Pin
6	40402008	定位销	Retaining Pin
7	40601006	割刀片	Cutting Wheel
8	50705005	割刀轴弹簧圈Φ1.4x9	Cutter Shaft Ring Φ1.4x9
9	42001018	割刀轴组件 (1)	Wheel pin
10	40403029	滚轮 (2)	Roll (2)
11	50705006	滚珠轴弹簧圈Φ1.4x10 (2)	Ring Φ1.4x10 (2)
12	42001019	滚轮轴组件 (2)	Roll pin (2)
13	40304018	滚轮架	Roll Housing Assembly
	10801003	割刀总成	Cutter complete





支架部件 660 (38801)

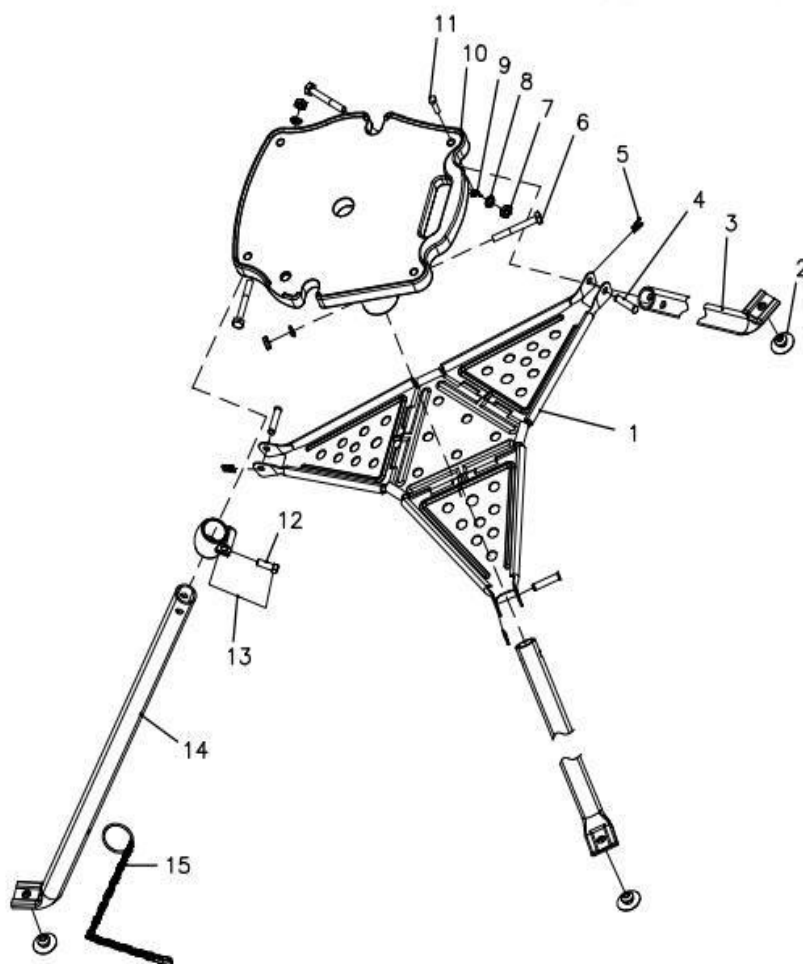

S/N	Ref. No.	品名	Description
1	30202010	支撑板组件	Tool Tray
2	41901008	橡胶脚 (3)	Grommet (3)
3	41701011	前支脚 (2)	Front Leg (2)
4	40402013	支撑销 (3)	Pin (3)
5	41001017	开口挡圈 (3)	X-Washer (3)
6	50101031	六角头螺栓UNC3/8-16x3 1/4 (3)	Bolt UNC3/8-16x3 1/4 (3)
7	50102028	六角螺母UNC3/8-16 (3)	Nut UNC3/8-16 (3)
8	50107044	标准弹性垫圈UNC3/8 (3)	Spring Washer UNC3/8 (3)
9	50102020	蝶型螺母M10 (GB/T62-1988) (4)	Wing Nut (4)
10	40901034	托板	Base
11	50101020	外六角螺栓M10x60 (GB/T5780-86) (4)	Bolt M10x60 (4)
12	50103171	方头凹端紧定螺钉	Screw
13	30108021	滑套组件	Tray & Leg Assembly
14	41702007	后支脚	Rear Leg
15	30101001	链条组件	Leg chain Assembly
	11001005	支架总成	
	30109052	三角支撑板及支脚组合件	





支架部件 661 (38802)

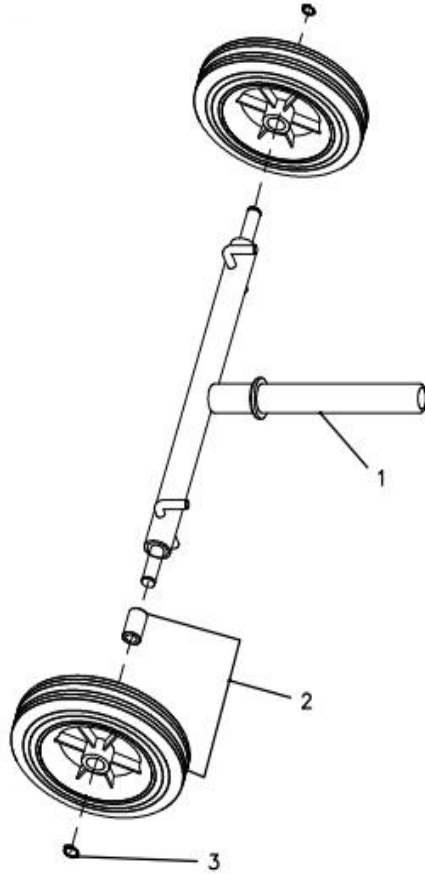

S/N	Ref. No.	品名	Description
1	30202014	轮轴焊接件	Axle & Support Tube Assembly
2	30109056	车轮 (2)	Wheel (2)
3	50108021	轴用弹性挡圈D=10 (GB/T894.1-1986) (2)	Retaining Ring (2)
	11001006	T形车架	T transporter





油枪部件 662 (88400)

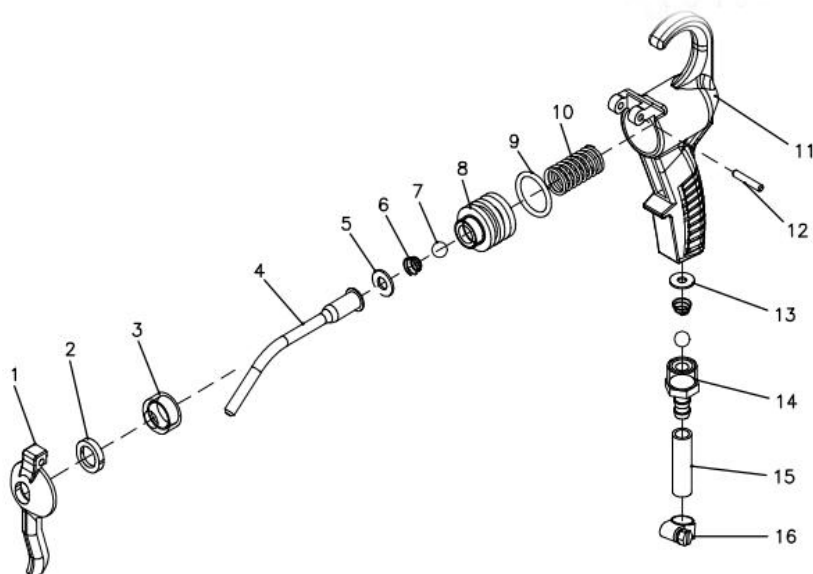

S/N	Ref. No.	品名	Description
1	40901053	油枪盖	trigger
2	41502037	尼龙垫	Nylon Washer
3	41901017	喷嘴盖	Retainer
4	41705046	喷嘴	Oil Spout
5	41502036	橡胶垫9.5x20x3	Rubber Washer 9.5x20x3
6	50702029	宝塔弹簧6x10x14 (2)	Spring 6x10x14 (2)
7	50402007	钢球D=11 (GB/T308-84) (2)	Steel Ball D=11 (2)
8	40402026	活塞	Piston
9	50801016	O型密封圈Φ28x3.55 (GB/T3452.1-2005)	O Ring
10	50702030	大弹簧Φ2x19x69x13	Spring Φ2x19x69x13
11	40901054	油枪体	Oil Gun Body
12	50105011	圆柱销Φ5x28 (GB/T119-86)	Pin Φ5x28
13	50107015	垫片D=6 (GB/T5287-2002)	Spacer D=6
14	40402027	油管接头	Fitting
15	41705047	输油管	oil hose
16	50109005	钢丝卡圈φ16	Wire Clip
	11102004	油枪带皮管	Oil Gun with Hose
	11102001	油枪油桶	oiler complete
	11102002	油枪总成不带皮管	





油桶部件 663 (88401)

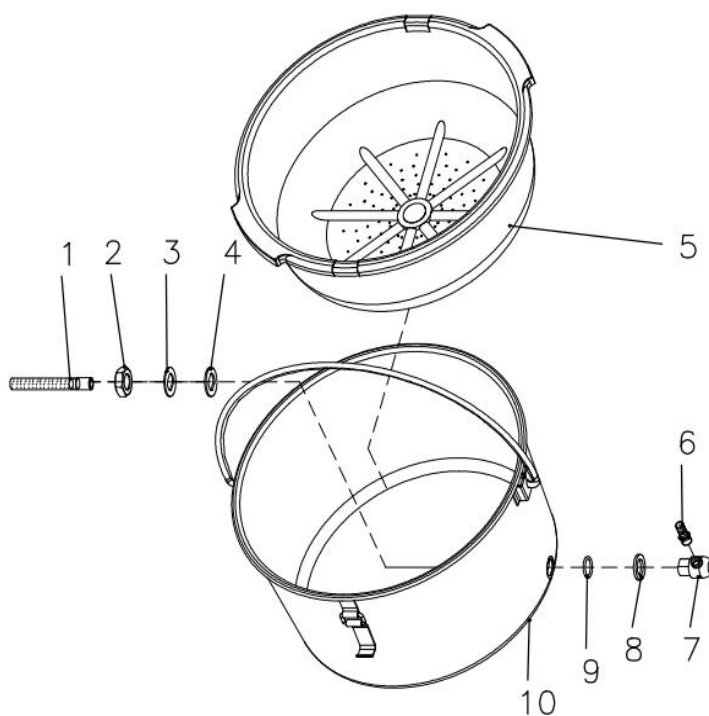

S/N	Ref. No.	品名	Description
1	30110003	滤网组件	strainer
2	50102015	六角薄螺母M20x1.5 (GB/T61782-86)	Nut M20x1.5
3	41502039	止转垫圈	Washer
4	41502038	透明垫圈	Washer
5	41601007	盛屑盘	Drip pan
6	40402029	管接头	Fitting
7	40401038	接头	Coupling
8	41502040	垫圈	Washer
9	50801014	O型密封圈Φ18x2.65 (GB/T3542.1-92)	O Ring Φ18x2.65
10	30112008	油桶组件	Oil Pan Component
11	11102001	油枪油桶	oiler complete
12	30108039	油枪接头组件#1+2+3+4+6+7+8+9.	





脚踏开关部件 711 (37701)

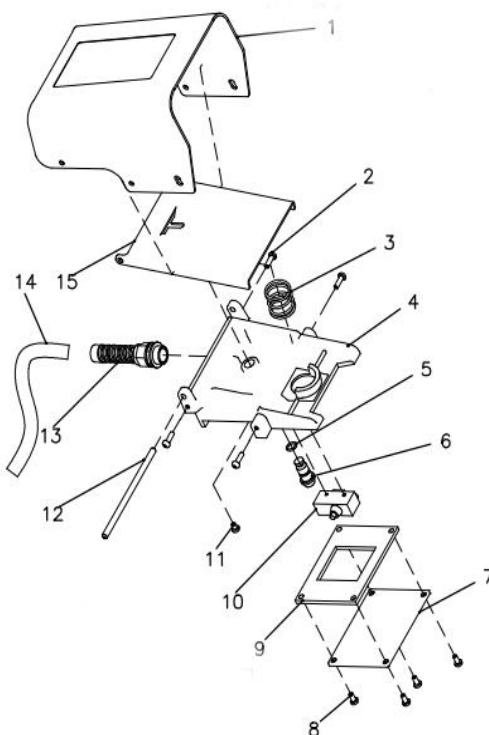

S/N	Ref. No.	Ref. No.	品名	Description
1	37786	41001010	外罩	Cover
2	09110	50103143	十字盘头螺钉UNC10#-24x3/8 (4)	Screw UNC10#-24x3/8 (4)
3	37775	50702004	压缩弹簧2.5x28.5x45	Compression Spring 2.5x28.5x45
4	37785	40901030	壳体	Base
5	04512	50801008	O型密封圈9.5x1.8 (GB/T3452.1-92)	O Ring 9.5x1.8
6	37777	40402010	圆锥销	Poppet
7	37781	41403002	底盖	Bottom Cover
8	09110	50103143	十字盘头螺钉UNC10#-24x3/8 (4)	Bottom Cover Screw UNC10#-24x3/8 (4)
9	37771	41402003	密封垫	Seal
10	37796	30402008	行程开关	Micro Switch
11	37767	#N/A	地线螺钉	Screw
12	37779	40402011	长销	Pivot Pin
13	37795	30402007	螺旋拉不脱20x1.5	Cord Connector 20x1.5
14	37787	30402014	美式连接线	Line Cord
15	37783	41403003	脚踏板	Foot Pedal
	37701	11103001	脚踏开关 42型	Foot Switch



旧货号	旧图号	新号	名称
	37611 62415	41801010	顶柱
	37613 62417	40402008	定位销
	37615 62419	40601003	滚刀片
	37619 62425	40402009	支撑销
	37621 62427	40403029	滚珠
	37623 62429	42001017	连接轴
	37625 62431	40304018	滚珠架
	37627 62433	40304019	割刀架
	37692 62407	30104004	手柄组件
	37629 62451	50705005	滚刀簧圈(50D)
	37631 62453	42001018	滚刀轴
	37633 62461	50705006	滚珠簧圈(50D)
	37635 62463	42001019	滚珠轴