



Standard Specification for Stainless Chromium Steel-Clad Plate¹

This standard is issued under the fixed designation A 263; the number immediately following the designation indicates the year of original adoption or, in the case of revision, the year of last revision. A number in parentheses indicates the year of last approval. A superscript epsilon (ϵ) indicates an editorial change since the last revision or reapproval.

1. Scope

1.1 This specification² covers plate of a carbon steel or low-alloy steel base to which is integrally and continuously bonded on one or both sides a layer of stainless chromium steel. The material is generally intended for pressure vessel use.

1.2 The values stated in inch-pound units are to be regarded as the standard.

2. Referenced Documents

2.1 ASTM Standards:

A 6/A 6M Specification for General Requirements for Rolled Structural Steel Bars, Plates, Shapes, and Sheet Piling³

A 20/A 20M Specification for General Requirements for Steel Plates for Pressure Vessels³

A 240/A 240M Specification for Chromium and Chromium-Nickel Stainless Steel Plate, Sheet, and Strip for Pressure Vessels and for General Applications⁴

A 370 Test Methods and Definitions for Mechanical Testing of Steel Products⁴

A 480/A 480M Specification for General Requirements for Flat-Rolled Stainless and Heat-Resisting Steel Plate, Sheet, and Strip⁴

A 578/A 578M Specification for Straight-Beam Ultrasonic Examination of Plain and Clad Steel Plates for Special Applications³

A 751 Test Methods, Practices, and Terminology for Chemical Analysis of Steel Products⁴

2.2 ASME Code:

Boiler and Pressure Vessel Code, Section IX, Welding Qualifications⁵

3. Terminology

3.1 Definitions of Terms Specific to This Standard:

3.1.1 This material is considered as single-clad or double-clad stainless chromium-steel plate, depending on whether one or both sides are covered.

3.1.2 *base metal (backing steel)*—component to which the alloy cladding is applied, usually the greater percentage of the composite plate.

3.1.3 *alloy cladding*—the stainless chromium steel component of the composite plate.

3.1.4 *integrally and continuously bonded*—a condition in which the alloy cladding and base metal are brought together to form a metallurgical bond at essentially the entire interface of the two metals by means other than those processes that do not produce a homogeneous composite plate.

4. Ordering Information

4.1 It is the responsibility of the purchaser to specify all requirements that are necessary for material ordered under this specification. Such requirements may include, but are not limited to, the following:

4.1.1 Quantity (weight or number of pieces).

4.1.2 Cladding alloy specification (UNS or ASTM Specification A 240/A 240M) and whether cladding is for corrosion allowance only.

4.1.3 Base metal specification.

4.1.4 Bond integrity Class (1, 3, or 5; see Section 13).

4.1.5 Dimensions including the minimum or nominal thicknesses of the cladding alloy and the backing steel, or of the total composite and if more or less restrictive thickness tolerances apply.

4.1.6 Product analysis, if required (see Section 10). Specify whether applicable to the cladding alloy, backing steel, or both.

4.1.7 Mechanical properties including shear test if required (see Sections 7, 8, and 9).

4.1.8 Finish (see Section 12).

4.1.9 Restrictions, if required, on repair by welding (see Section 14).

4.1.10 Additions to the specification or special requirements.

¹ This specification is under the jurisdiction of ASTM Committee A01 on Steel, Stainless Steel and Related Alloys and is the direct responsibility of Subcommittee A01.17 for Flat-Rolled and Wrought Stainless Steel.

Current edition approved February 10, 2003. Published April 2003. Originally approved in 1943. Last previous edition approved in 1999 as A 263 – 94a (1999).

² For ASME Boiler and Pressure Vessel Code applications see related Specification SA-263 in Section II of that Code.

³ *Annual Book of ASTM Standards*, Vol 01.04.

⁴ *Annual Book of ASTM Standards*, Vol 01.03.

⁵ Available from American Society of Mechanical Engineers (ASME), ASME International Headquarters, Three Park Ave., New York, NY 10016-5990.

4.2 In addition to the basic requirements of this specification and the backing steel specification, certain supplementary requirements are available when necessary to meet end use requirements. These include:

- 4.2.1 Nondestructive examination,
- 4.2.2 Impact testing, and
- 4.2.3 Simulated Post-Weld Heat Treatment of Mechanical Test Coupons (SPWHT).

4.3 The purchaser is referred to the listed supplementary requirements in this specification and to the detailed requirements in Specification A 20/A 20M.

4.4 If the requirements of this specification are in conflict with the requirements of Specification A 20/A 20M, the requirements of this specification shall prevail.

5. Materials and Manufacture

5.1 Process:

5.1.1 The steel shall be made by the open-hearth, electric-furnace, or basic-oxygen processes, or by secondary processes whereby steel made from these primary processes is remelted using, but not limited to electroslag remelting or vacuum-arc remelting processes.

5.1.2 The alloy-cladding metal may be metallurgically bonded to the base metal by any method that will produce a clad steel that will conform to the requirements of this specification.

5.2 *Heat Treatment*—Unless otherwise specified or agreed upon between the purchaser and the manufacturer, all plates shall be furnished in the normalized, tempered, normalized and tempered, or quenched and tempered condition as permitted by the backing steel specification. Stress relieving of the composite plate by heating subcritically is permitted, provided the temperature is 75°F [40°C] or more below the minimum tempering temperature (when tempered).

6. Chemical Composition

6.1 The composite plate shall conform to any desired combination of alloy-cladding metal and base metal as described in 6.2 and 6.3 and as agreed upon between the purchaser and the manufacturer.

6.2 *Alloy Cladding Metal*—The alloy-cladding metal specified shall conform to the requirements as to chemical composition prescribed for the respective chromium steel in Specification A 240/A 240M.

6.3 *Base Metal*—The base metal shall be carbon steel or low-alloy steel conforming to the ASTM specifications for steels for pressure vessels or other as agreed by the purchaser and the manufacturer. The base metal shall conform to the chemical requirements of the specification to which it is ordered.

7. Mechanical Properties

7.1 Tensile Requirements:

7.1.1 The tensile properties shall be determined by a tension test of the composite plate for clad plates that meet all of the following conditions.

- (a) The nominal composite gage is less than or equal to 1½ in.

- (b) The specified minimum tensile strength of the base steel is less than or equal to 70 000 psi [485 MPa].

- (c) The specified minimum yield strength of the base steel is less than or equal to 40 000 psi [275 MPa].

The tensile properties thus determined shall be not less than the minimum and not more than 5000 psi [35 MPa] over the maximum prescribed in the specification for the base steel used. All other tensile test requirements of the specification for the base steel shall be met.

7.1.2 The tensile properties shall be determined by a tension test of the base steel only for clad plates that meet one of the following conditions. The properties thus determined shall meet all of the tensile test requirements for the base steel.

- (a) The composite gage is greater than 1½ in.

- (b) The specified minimum tensile strength of the base steel is greater than 70 000 psi [485 MPa].

- (c) The specified minimum yield strength of the base steel is greater than 40 000 psi [275 MPa].

7.1.3 If the cladding is for corrosion allowance only, the cladding need not be included in the tensile test. The tensile properties thus determined shall meet the base steel requirements.

7.2 Tests for strength of the bond, when required, must be specified by the purchaser and shall consist of one of the following.

7.2.1 *Shear Strength*—When required by the purchaser, the minimum shear strength of the alloy cladding and base metals shall be 20 000 psi [140 MPa]. The shear test, when specified, shall be made in the manner indicated in Fig. 1. The minimum cladding thickness for shear testing shall be 0.075 in. [1.9 mm] exclusive as ordered.

7.2.2 *Bond Strength*—As an alternative to the shear strength test provided in 7.2.1, or when agreed upon by the purchaser and the manufacturer, or both, three bend tests shall be made

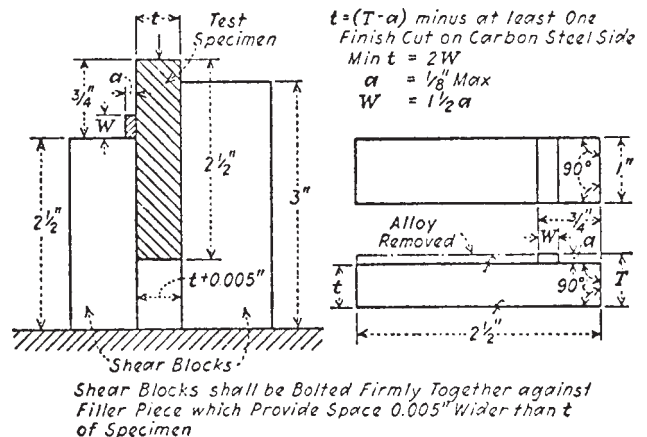

Metric Equivalents

in.	mm	in.	mm
0.005	0.127	1	25.4
1/8	3.18	2 1/2	64.5
3/4	19.1	3	76.2

FIG. 1 Test Specimen and Method of Making Shear Test of Clad Plate

with the alloy cladding in compression to determine the quality of the bond. These bend tests shall be made in the manner of the tension tests indicated in Fig. 2 and shall be bent through an angle of 180° to the bend diameters provided for in either Specification A 6/A 6M or Specification A 20/A 20M, Appendix X4 or equivalent, as applicable. At least two of the three tests shall show not more than 50 % separation on both edges of the bent portion. Greater separation shall be cause for rejection.

7.3 Methods and practices relating to mechanical testing required by this specification shall be in accordance with Test Methods and Definitions A 370.

8. Number of Tests and Retests

8.1 One or more tension tests, as required by the specifications for the base metal and, when specified, one shear test or three bond bend tests shall be made representing each plate as rolled. Each specimen shall be in the final condition of heat treatment required for the plate, including any SPWHT if required.

8.2 If any test specimen shows defective machining or develops flaws, it may be discarded and another specimen substituted.

9. Test Specimens

9.1 The tension test specimens from plate shall conform to the requirements prescribed in the specifications for the base metal.

9.2 Bend test specimens for the alternative bond strength tests shall be taken at right angles to longitudinal axis of the plate.

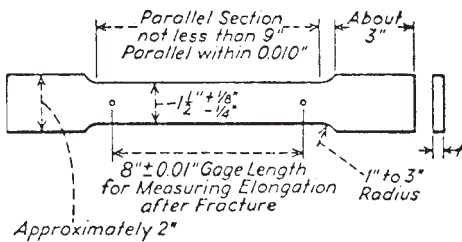

Metric Equivalents			
in.	mm.	in.	mm.
0.01	0.254	1 1/2	38.1
1/8	3.17	2	50.8
1/4	6.35	3	76.2
1	25.4	8	203.2

NOTE 1—When necessary, it is permissible to use a narrower specimen, but in such a case the reduced portion shall be not less than 1 in. in width.

NOTE 2—Punch marks for measuring elongation after fracture shall be made on the flat or on the edge of the specimen and within the parallel section; either a set of nine punch marks 1 in. apart, or one or more sets of 8-in. punch marks may be used.

NOTE 3—The dimension *t* is the thickness of the test specimen as provided for in the applicable material specifications.

FIG. 2 Standard Rectangular Tension Test Specimen with 8-in. Gage Length

9.3 When required by the purchaser, the shear test specimen should be taken near a corner of the plate, parallel to its longitudinal axis, or other location that is representative of the final product.

9.4 For plates 1 1/2 in. [38 mm] and under in thickness tension test specimens shall be full thickness of the material except as specified in 7.1.1 and 7.1.2.

9.5 For plates over 1 1/2 in. [38 mm] in thickness, tension tests shall be of the form shown in Fig. 3 and shall be of all base steel conforming to the requirements of the specification for the base steel.

9.6 The bend test specimen used for bond strength determination shall be 1 1/2 in. wide [38 mm] by not more than 3/4 in. [19 mm] in thickness and shall be machined to the form and dimensions shown in Fig. 2, or may be machined with both edges parallel. In reducing the thickness of the specimen, both the alloy cladding and the base steel shall be machined so as to maintain the same ratio of clad metal to base steel as is maintained in the plate, except that the thickness of the clad metal need not be reduced below 1/8 in. [3.1 mm]. The sides of the bend test specimen used for bond strength determination may have the corners rounded to a radius not over 1/16 in. [1.6 mm] for plates, 2 in. [50 mm] and under in thickness, and not over 1/8 in. [3.1 mm] for plates over 2 in. [50 mm] in thickness.

10. Product Analysis

10.1 Product analysis may be required for the cladding alloy on the finished product. Chemical analysis may be accomplished by wet chemical or instrumental procedures. If wet chemical procedures are used, millings may be taken only when the composite plate thickness is sufficient to permit obtaining millings without danger of contamination from the adjacent layer. If spectrometric procedures are used, the sample shall be exposed on the center line of the cladding when there

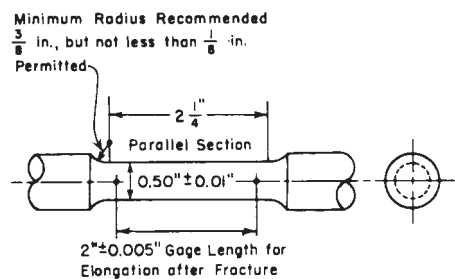

Metric Equivalents			
in.	mm.	in.	mm.
0.003	0.076	3/8	9.53
0.005	0.127	0.50	12.7
0.01	0.254	2	50.8
1/8	3.18	2 1/4	64.5

NOTE—The gage length and fillets shall be as shown, but the ends may be of any shape to fit the holders of the testing machine in such a way that the load shall be axial. The reduced section shall have a gradual taper from the ends toward the center, with the ends 0.003 to 0.005 in. larger in diameter than the center.

FIG. 3 Standard Round Tension Test Specimen with 2-in. Gage Length

is sufficient cladding thickness available so that there is no contamination from the adjacent base metal.

10.2 If product analysis is specified by the purchaser for the cladding alloy, it shall be made from drillings or millings taken from the final piece or a broken test specimen. For wet chemical analysis, in order to avoid contamination by the base plate metal, millings of cladding samples shall be taken from the test coupon by removal and discard of all the base metal plate material, plus 40 % of the cladding thickness from the bonded side, not to exceed $\frac{1}{16}$ in. [1.6 mm]. The material shall be chemically cleaned and sufficient millings shall be taken to represent the full cross-section of the remainder. If there is insufficient cladding thickness available to spectrographically expose on the center line of the cladding without contamination, 50 % of the cladding shall be removed and the sample exposed on this surface.

10.3 Methods and practices relating to chemical analysis required by this specification shall be in accordance with Test Methods, Practices, and Terminology A 751.

10.4 Results of the product analysis shall conform to the requirements of Section 7 of Specification A 480/A 480M.

10.5 Results of the product analysis for the backing steel when required shall conform to the requirements of Section 7 of Specification A 20/A 20M.

11. Permissible Variations

11.1 Permissible variations except for thickness shall be in accordance with Specification A 20/A 20M.

11.2 Minimum thickness of the alloy cladding metal and of the backing steel, or of the total composite plate shall be as required by purchase order documents when ordered to minimum thicknesses.

11.3 Permissible variation in thickness when ordered to nominal thicknesses shall be 0.01 in. [0.3 mm] under each for backing steel or total composite, and 0.03 in. [0.8 mm] under for the alloy cladding.

11.4 Permissible variations for excess thickness of the total composite shall be the greater of 0.125 in. [3 mm] or 10 % of the total composite thickness ordered and may occur in either backing steel, cladding, or both, provided the minimum for each is met.

11.5 More restrictive or less restrictive permissible variations may be agreed upon by the purchaser and the manufacturer.

12. Workmanship, Finish, and Appearance

12.1 The material shall be free of injurious defects, shall have a workmanlike appearance, and shall conform to the designated finish.

12.2 Plate alloy surfaces shall be blasted (descaled by means such as sand or stainless grit, shot or wire, or equivalent), pickled, blast-cleaned and pickled, or 100 % conditioned.

13. Bond Quality

13.1 The cladding metal shall be integrally and continuously bonded to the base metal.

13.2 Inspection

13.2.1 Clad plates less than $\frac{3}{8}$ in. [10 mm] total minimum composite thickness shall be visually inspected for bond integrity prior to shipment.

13.2.2 Clad plates $\frac{3}{8}$ in. [10 mm] and thicker total minimum composite thickness shall be ultrasonically inspected for bond integrity prior to shipment in accordance with the procedures and methods of Specification A 578/A 578M.

13.2.3 Areas of non-bond detected visually shall be explored ultrasonically to determine the extent of the condition per 13.2.2. For purposes of defining non-bond, the cladding shall be interpreted to be unbonded when there is complete loss of back reflection accompanied by an echo indication from the plane of the interface of the clad and backing steel. Areas within 1 in. [25 mm] of a cut edge on the plate that contain indications exceeding 50 % of the back reflection at the bond interface shall be considered to be unbonded.

13.2.4 Extent of ultrasonic examination shall be at the discretion of the manufacturer and sufficient enough to provide the quality level required by the purchaser. Plates may be ordered with 100 % coverage (S1).

13.3 Quality Levels

13.3.1 *Class 1*—No single unbonded area exceeding 1 in. [25 mm] in its longest dimension with total unbonded area not to exceed 1 % of the total clad surface area.

13.3.2 *Class 3*—No single unbonded area exceeding 3 in. [75 mm] in its longest dimension with total unbonded area not to exceed 3 % of the total clad surface area.

13.3.3 *Class 5*—No single unbonded area exceeding 9 in.² [58 cm²] with total unbonded area not to exceed 5 % of the total clad surface area.

13.3.4 The Class to be supplied should be listed on the purchase order. When none has been specified, plates shall be furnished as Class 5 at the option of the manufacturer.

14. Repair of Cladding by Welding

14.1 The material manufacturer may repair defects in cladding by welding provided the following requirements are met:

14.1.1 When specified in the purchase order, prior approval shall be obtained from the purchaser.

14.1.2 The welding procedure and the welders or welding operators shall be qualified in accordance with Section IX of the ASME Code.

14.1.3 The defective area shall be removed and the area prepared for repair shall be examined by a magnetic particle method or a liquid penetrant method to ensure all defective area has been removed. Method of test and acceptance standard shall be as agreed upon between the purchaser and the manufacturer.

14.1.4 The repair weld shall be deposited in accordance with a welding procedure and welding materials suitable for the cladding material. The surface condition of the repaired area shall be restored to a condition similar to the rest of the cladding.

14.1.5 The repaired area shall be examined by a liquid penetrant method.

14.1.6 The location and extent of the weld repairs together with the repair procedure and examination results shall be transmitted as a part of the certification.

14.2 All repairs in Alloy type 410 and any repairs to type 410S penetrating into the backing steel shall be stress relieved to eliminate residual stresses unless otherwise agreed upon.

15. General Requirements for Delivery

15.1 Material furnished under this specification shall conform to the applicable requirements of the current edition of Specification A 20/A 20M.

16. Certification

16.1 The chemical analysis of the base metal and the alloy cladding shall be certified to the purchaser by the clad plate manufacturer.

16.2 The results of the tests in Section 7 and any other tests required by the purchase order shall be reported to the purchaser.

16.3 Compliance with the clad quality level of 13.3 shall be certified. Reports shall include the results of ultrasonic inspection when Supplementary Requirement S.12 is specified.

17. Product Marking

17.1 Except as specified in 17.2, plates shall be marked in accordance with the requirements of Specification A 20/A 20M for the backing steel and the type number of the alloy cladding metal and this specification number.

17.2 For double-clad material or for material under ¼ in. [6.35 mm] in thickness, the marking shall be legibly stenciled instead of stamped.

18. Keywords

18.1 alloy cladding; backing steel; bond strength; carbon steel; clad steel plate; low-alloy steel; pressure vessel; shear strength; stainless chromium steel

SUPPLEMENTARY REQUIREMENTS

Supplementary requirements shall not apply unless specified on the order. A list of standardized supplementary requirements for use at the option of the purchaser are included in Specification A 20/A 20M. Several of those considered suitable for use with this specification are listed below by title. Other tests may be performed by agreement between the supplier and the purchaser.

S2. Product Analysis

S3. Simulated Post-Weld Heat Treatment of Mechanical Test Coupons

S5. Charpy V-Notch Impact Test

S12. Ultrasonic Examination in accordance with Specification A 578/A 578M

SUMMARY OF CHANGES

Committee A01 has identified the location of selected changes to this standard since the last issue (A 263–94a (1999)) that may impact the use of this standard.

(1) A general revision was made, including revisions to the title and scope.

(2) References and tolerances pertaining to sheet and strip clad products have been deleted as not appropriate to be included

with plate products. An improved method of describing quality levels for bond integrity are introduced. More descriptive treatment of permitted variations in clad and backing thickness as well as a general rewording of the specification throughout.

ASTM International takes no position respecting the validity of any patent rights asserted in connection with any item mentioned in this standard. Users of this standard are expressly advised that determination of the validity of any such patent rights, and the risk of infringement of such rights, are entirely their own responsibility.

This standard is subject to revision at any time by the responsible technical committee and must be reviewed every five years and if not revised, either reapproved or withdrawn. Your comments are invited either for revision of this standard or for additional standards and should be addressed to ASTM International Headquarters. Your comments will receive careful consideration at a meeting of the responsible technical committee, which you may attend. If you feel that your comments have not received a fair hearing you should make your views known to the ASTM Committee on Standards, at the address shown below.

This standard is copyrighted by ASTM International, 100 Barr Harbor Drive, PO Box C700, West Conshohocken, PA 19428-2959, United States. Individual reprints (single or multiple copies) of this standard may be obtained by contacting ASTM at the above address or at 610-832-9585 (phone), 610-832-9555 (fax), or service@astm.org (e-mail); or through the ASTM website (www.astm.org).