



Standard Specification for Carbon and Alloy Steel Nuts for Bolts for High Pressure or High Temperature Service, or Both¹

This standard is issued under the fixed designation A 194/A 194M; the number immediately following the designation indicates the year of original adoption or, in the case of revision, the year of last revision. A number in parentheses indicates the year of last reapproval. A superscript epsilon (ε) indicates an editorial change since the last revision or reapproval.

This standard has been approved for use by agencies of the Department of Defense.

Note—Corrections to Table 2 and paragraph S3.1 were made editorially and the year date was changed on October 28, 2003.

1. Scope*

1.1 This specification² covers a variety of carbon, alloy, and martensitic stainless steel nuts in the size range ¼ through 4 in. and metric M6 through M100 nominal. It also covers austenitic stainless steel nuts in the size range ¼ in. and M6 nominal and above. These nuts are intended for high-pressure or high-temperature service, or both. Grade substitutions without the purchaser's permission are not allowed.

1.2 Bars from which the nuts are made shall be hot-wrought. The material may be further processed by centerless grinding or by cold drawing. Austenitic stainless steel may be solution annealed or annealed and strain-hardened. When annealed and strain hardened austenitic stainless steel is ordered in accordance with Supplementary Requirement S1, the purchaser should take special care to ensure that 7.2.2, Supplementary Requirement S1, and Appendix X1 are thoroughly understood.

1.3 Supplementary requirements (S1 through S6) of an optional nature are provided. These shall apply only when specified in the inquiry, contract, and order.

1.4 This specification is expressed in both inch-pound units and in SI units. However, unless the order specifies the applicable "M" specification designation (SI units), the material shall be furnished to inch-pound units.

1.5 The values stated in either inch-pound units or SI units are to be regarded separately as standard. Within the text, the SI units are shown in brackets. The values stated in each system are not exact equivalents; therefore, each system must be used independently of the other. Combining values from the two systems may result in nonconformance with the specification.

¹ This specification is under the jurisdiction of ASTM Committee A01 on Steel, Stainless Steel and Related Alloys and is the direct responsibility of Subcommittee A01.22 on Steel Forgings and Wrought Fittings for Piping Applications and Bolting Materials for Piping and Special Purpose Applications.

Current edition approved Oct. 28, 2003. Published November 2003. Originally approved in 1936. Last previous edition approved in 2003 as A 194/A 194M-03a.

² For ASME Boiler and Pressure Vessel Code applications see related Specification SA-194 in Section II of that code.

2. Referenced Documents

2.1 ASTM Standards:³

- A 153/A 153M Specification for Zinc Coating (Hot-Dip) on Iron and Steel Hardware
 - A 276 Specification for Stainless Steel Bars and Shapes
 - A 320/A 320M Specification for Alloy-Steel Bolting Materials for Low-Temperature Service
 - A 370 Test Methods and Definitions for Mechanical Testing of Steel Products
 - A 962/A 962M Specification for Common Requirements for Steel Fasteners or Fastener Materials, or Both, Intended for Use at Any Temperature from Cryogenic to the Creep Range
 - B 633 Specification for Electrodeposited Coatings of Zinc on Iron and Steel
 - B 695 Specification for Coatings of Zinc Mechanically Deposited on Iron and Steel
 - B 696 Specification for Coatings of Cadmium Mechanically Deposited
 - B 766 Specification for Electrodeposited Coatings of Cadmium
 - E 112 Test Methods for Determining Average Grain Size
- ### 2.2 American National Standards:⁴
- B 1.1 Unified Screw Threads
 - B 1.13M Metric Screw Threads
 - B 18.2.2 Square and Hex Nuts
 - B 18.2.4.6M Metric Heavy Hex Nuts

3. Terminology

3.1 Definitions of Terms Specific to This Standard:

- 3.1.1 *Austenitic Grades*—All grades with a prefix of "8" or "9".

³ For referenced ASTM standards, visit the ASTM website, www.astm.org, or contact ASTM Customer Service at service@astm.org. For *Annual Book of ASTM Standards* volume information, refer to the standard's Document Summary page on the ASTM website.

⁴ Available from American National Standards Institute, 25 W. 43rd St., 4th Floor, New York, NY 10036.

*A Summary of Changes section appears at the end of this standard.

3.1.2 *Ferritic Grades*—Grades 1, 2, 2H, 2HM, 3, 4, 6, 6F, 7, 7M, and 16.

3.1.3 *Lot*:

3.1.3.1 Unless otherwise specified (see 3.1.3.2), a lot is the quantity of nuts of a single nominal size and grade produced by the same manufacturing process.

3.1.3.2 When Supplementary Requirement S5 is invoked on the purchase order, the following definitions of a lot shall apply:

For Grade 8 Nuts—The quantity of all the nuts of a single nominal diameter and grade made from the same heat of steel and made by the same manufacturing process.

For All Other Grade Nuts (see 7.2 and 7.1.2.1)—All the nuts of a single nominal diameter and grade made from the same heat number and heat treated in the same batch if batch-type heat treating equipment is used or heat treated in the same continuous run of not more than 8 h under the same conditions if continuous-type heat treating equipment is used.

3.1.4 *For Grade 8 Nuts*—Variations within the grade designated by a letter and differentiated by chemistry and by manufacturing process.

3.1.5 *For Grade 6 Nuts*—Variations within the grade designated by the letter F as differentiated by chemical additions made for machineability.

3.1.6 *Series*—The dimensional relationship and geometry of the nuts as described in ANSI B 18.2.2 or B 18.2.4.6M.

4. Ordering Information

4.1 The inquiry and order for material under this specification shall include the following as required to describe the material adequately:

4.1.1 Specification designation, year date, and grade, issue date and revision letter,

4.1.2 Quantity, number of pieces,

4.1.3 Dimensions (see Section 8),

4.1.4 Options in accordance with 7.2.2.1, 8.1, 8.2, 9.3, and 11, and

4.1.5 Supplementary Requirements, if any.

4.2 *Coatings*—Coatings are prohibited unless specified by the purchaser. Nuts plated with cadmium or zinc shall be marked as stated in 12.2. When coated nuts are ordered, the purchaser should take special care to ensure that Appendix X2 is thoroughly understood. It is the purchaser's responsibility to specify in the purchase order all information required by the coating facility. Examples of such information may include, but are not limited to, the following:

4.2.1 Reference to the appropriate coating specification: Specifications B 766, B 696, A 153/A 153M, B 695, B 633, or other specifications as agreed upon by the purchaser and manufacturer.

4.2.2 Requirements for coating thickness and local or batch average thickness measurement, or both.

4.2.3 Requirements for selective plating or coating or modification of dimensions to accommodate coating.

4.2.4 Requirements for hydrogen embrittlement relief.

4.3 See Supplementary Requirement S3 for nuts to be used in low temperature applications (Specification A 320/A320M).

5. Common Requirements

5.1 Material and fasteners supplied to this specification shall conform to the requirements of Specification A 962/A 962M. These requirements include test methods, finish, thread dimensions, marking, certification, optional supplementary requirements, and others. Failure to comply with the requirements of Specification A 962/A 962M constitutes nonconformance with this specification. In case of conflict between the requirements of this specification and Specification A 962/A 962M, this specification shall prevail.

6. Manufacture (Process)

6.1 Stainless steels for all types of Grade 6 and 8 nuts shall be made by one of the following processes:

6.1.1 Electric-furnace (with separate degassing and refining optional),

6.1.2 Vacuum induction furnace, or

6.1.3 Either of the above followed by electroslag remelting, or consumable-arc remelting.

6.2 The steel producer shall exercise adequate control to eliminate excessive unhomogeneity, nonmetallics, pipe, porosity, and other defects.

6.3 Grades 1 and 2 nuts shall be hot or cold forged, or shall be machined from hot-forged, hot-rolled, or cold-drawn bars.

6.3.1 All Grade 1 and 2 nuts made by cold forging or by machining from cold-drawn bars shall be stress-relief annealed at a temperature of at least 1000°F [538°C].

6.3.2 Grade 1 and 2 nuts made by hot forging or by machining from hot-forged or hot-rolled bars need not be given any stress relief annealing treatment.

6.4 Grades 2H, 2HM, 3, 4, 6, 6F, 7, 7M, and 16 nuts shall be hot- or cold-forged or shall be machined from hot-forged, hot-rolled, or cold-drawn bars and shall be heat treated to meet the required mechanical properties. These grades shall be reheated above the critical range of the steel, quenched in a suitable medium, and then tempered at a temperature not less than the following:

Grade	Minimum Tempering Temperature, °F	
	[°C]	
2H	850	[455]
2HM	1150	[620]
3	1050	[565]
4	1100	[595]
6 and 6F	1100	[595]
7	1100	[595]
7M	1150	[620]
16	1200	[650]

Nuts machined from bar heat treated in accordance with this specification need not be reheat-treated. For Grade 2HM and 7M nuts, a final stress relief shall be done at or above the minimum tempering temperature after all forming, machining, and tapping operations. This final stress relief may be the tempering operation.

6.4.1 Grade 6 and 6F nuts shall be tempered for a minimum of 1 h at the temperature.

6.5 Grades 8, 8C, 8M, 8T, 8F, 8P, 8N, 8MN, 8R, 8S, 8LN, 8MLN, 8MLCuN, and 9C nuts shall be hot or cold forged, or shall be machined from hot-forged, hot-rolled or cold-drawn bars.



6.6 Grades 8A, 8CA, 8MA, 8TA, 8FA, 8PA, 8NA, 8MNA, 8RA, 8SA, 8LNA, 8MLNA, 8MLCuNA, and 9CA nuts shall be hot- or cold-forged or shall be machined from hot-forged, hot-rolled, or cold-drawn bars and the nuts shall subsequently be carbide-solution treated by heating them for a sufficient time at a temperature to dissolve chromium carbides followed by cooling at a rate sufficient to prevent reprecipitation of the carbides.

7. Mechanical Requirements

7.1 Hardness Test:

7.1.1 Requirements:

7.1.1.1 All nuts shall be capable of meeting the hardness requirements specified in Table 2.

7.1.1.2 Sample nuts of Grades 1, 2, 2H, 2HM, 3, 4, 7, 7M, and 16 which have been given the treatment described in 7.1.5 shall meet the minimum hardness specified in Table 2.

7.1.2 *Number of Tests*— (Grades 1, 2, 2H, 3, 4, 7, and 16 and all types of Grade 6):

7.1.2.1 Tests on the number of sample nuts in accordance with the following table shall be performed by the manufacturer following all production heat treatments:

Lot Size	Samples
Up to 800	1
801 to 8000	2
8001 to 22 000	3
Over 22 000	5

7.1.2.2 In addition, a hardness test shall be performed by the manufacturer in accordance with 7.1.5 on one sample nut selected from each nominal diameter and series from each grade and heat number following completion of all production heat treatments.

7.1.3 Number of Tests, Grades 2HM and 7M:

7.1.3.1 The maximum hardness of Grade 2HM and 7M shall be 235 HB or 99 HRB. Product which has been 100 % tested and found acceptable shall have a line under the “M.”

7.1.3.2 In addition, 7.1.2.2 shall be met.

7.1.4 *Number of Tests, All Types of Grade 8*—Tests on the number of sample nuts in accordance with 7.1.2.1 shall be performed by the manufacturer.

7.1.5 *Test 2*—In addition to the testing required by 7.1.2.1 the manufacturer shall also perform hardness tests on sample nuts after the following test heat treatment. After completion of all production heat treatments heat the specimen nuts to the temperatures indicated below for 24 h, then slow cool. Test at room temperature.

Grade	Temperature, °F [°C]
1	850 [455]
2, 2H, 2HM	1000 [540]
3, 4, 7, 7M	1100 [590]
16	1200 [650]

7.1.5.1 *Special Requirement, Grades 2HM and 7M*—Preparation of Grades 2HM and 7M nuts for hardness test and the hardness test itself shall be performed with consideration to (1) protect legibility of markings; (2) minimize exterior dimensional changes; and (3) maintain thread fit.

7.2 Proof Load Test:

7.2.1 *Requirements*—All nuts shall be capable of withstanding the proof loads specified in Table 3 and Table 4. However, nuts manufactured to dimensions and configurations other than those covered by ANSI B 1.1, ANSI B 1.13M, ANSI B 18.2.2, and B 18.2.4.6M are not subject to the proof load test.

7.2.2 Number of Tests:

7.2.2.1 Tests on the number of sample nuts in accordance with 7.1.2.1 shall be performed by the manufacturer following all production heat treatments except that, unless proof load testing or Supplementary Requirement S1 is specified in the order, nuts which would require a proof load in excess of 120 000 lbf or 530 kN may be furnished on the basis of minimum hardness requirements. Proof load testing of nuts requiring a proof load of over 120 000 lbf or 530 kN is covered in Supplementary Requirement S4.

7.2.3 *Test Method*—The test shall be in accordance with Annex A3, Paragraph A3.5.1, of Test Methods and Definitions A 370.

7.3 Cone Proof Load Test:

7.3.1 *Requirements*—This test shall be performed only when visible surface discontinuities become a matter of issue between the manufacturer and the purchaser. The requirements specified in Table 5 and Table 6 shall be met for the size range ¼ to 1½ in. and M6 to M36. Nuts not in this size range and all types of Grade 8 nuts are not subject to this test. Also, nuts manufactured to dimensions and configurations other than those covered by ANSI B 1.1, ANSI B 1.13M, ANSI B 18.2.2, and ANSI B 18.2.4.6M are not subject to the cone proof load test.

7.3.2 *Number of Tests*—Sample nuts in accordance with 7.1.2.1 shall be tested by the manufacturer.

7.3.3 *Test Method*—The test shall consist of assembling a hardened cone (see Fig. 1) and the nut to be tested on a hardened steel mandrel, and applying the proof load specified in Table 5 and Table 6. The mandrel shall conform to the requirements of Annex A3, Paragraph A3.5.1 of Test Methods and Definitions A 370 except that the threads shall be in accordance with ANSI B 1.1 of the appropriate thread series, Class 3A fit or ANSI B 1.13M of the appropriate thread pitch, tolerance 4H. The hardened cone shall be as described in Fig. 2. The lot shall be considered acceptable if the sample nut withstands application of the proof load without failure.

8. Dimensions

8.1 Nuts shall be hexagonal in shape, and in accordance with the dimensions for the hex or heavy hex series, as required, by ANSI B 18.2.2 and ANSI B 18.2.4.6M. Unless otherwise specified, the American National Standard Heavy Hex Series shall be used and nuts shall be either double chamfered or have a machined or forged washer face, at the option of the manufacturer, and, conform to the angularity requirements of ANSI B 18.2.2 and ANSI B 18.2.4.6M.

8.2 Unless otherwise specified, threads shall be in accordance with ANSI B 1.1 or ANSI B 1.13M, and shall be gaged in accordance with ANSI B 1.2 and ANSI B 1.13M as described in 8.2.1 and 8.2.2.

8.2.1 Nuts up to and including 1 in. nominal size shall be UNC Series Class 2B fit. Metric nuts up to and including M24 nominal size shall be coarse thread series tolerance 6H.



TABLE 1 Chemical Requirements^{A,B,C}

Grade Symbol	Material	UNS Number	Carbon, %	Manganese, %	Phosphorus, %	Sulfur, ^D %	Silicon, %	Chromium, %	Nickel, %	Molybdenum, %	Titanium, %	Columbium and Tantalum, %	Nitrogen, %	Other Elements, %
1	carbon		0.15 min	1.00	0.040	0.050	0.40
2, 2HM, and 2H	carbon		0.40 min	1.00	0.040	0.050	0.40
4	carbon, molybdenum		0.40–0.50	0.70–0.90	0.035	0.040	0.15–0.35	0.20–0.30
3	Type 501		0.10 min	1.00	0.040	0.030	1.00	4.0–6.0	...	0.40–0.65
6	Type 410	S41000	0.15	1.00	0.040	0.030	1.00	11.5–13.5
6F	Type 416	S41600	0.15	1.25	0.060	0.15 min	1.00	12.0–14.0
6F	Type 416Se	S41623	0.15	1.25	0.060	0.060	1.00	12.0–14.0	Selenium, 0.15 min
7, 7M	Type 4140/4142/4145, 4140H, 4142H, 4145H		0.37–0.49	0.65–1.10	0.035	0.04	0.15–0.35	0.75–1.20	...	0.15–0.25
8, 8A	Type 304	S30400	0.08	2.00	0.045	0.030	1.00	18.0–20.0	8.0–11.0
8C, 8CA	Type 347	S34700	0.08	2.00	0.045	0.030	1.00	17.0–19.0	9.0–12.0	10 x carbon content, min
8M, 8MA	Type 316	S31600	0.08	2.00	0.045	0.030	1.00	16.0–18.0	10.0–14.0	2.00–3.00
8T, 8TA	Type 321	S32100	0.08	2.00	0.045	0.030	1.00	17.0–19.0	9.0–12.0	...	5 x (C+N) min - 0.70 max
8F, 8FA	Type 303	S30300	0.15	2.00	0.20	0.15 min	1.00	17.0–19.0	8.0–10.0
8F, 8FA	Type 303Se	S30323	0.15	2.00	0.20	0.06	1.00	17.0–19.0	8.0–10.0	Selenium, 0.15 min
8P, 8PA	Type 305 with restricted carbon	S30500	0.08	2.00	0.045	0.030	1.00	17.0–19.0	11.0–13.0
8N, 8NA	Type 304N	S30451	0.08	2.00	0.045	0.030	1.00	18.0–20.0	8.0–11.0	0.10–0.16	...
8LN, 8LNA	Type 304LN	S30453	0.030	2.00	0.045	0.030	1.00	18.0–20.0	8.0–11.0	0.10–0.16	...
8MN, 8MNA	Type 316N	S31651	0.08	2.00	0.045	0.030	1.00	16.0–18.0	10.0–13.0	2.00–3.00	0.10–0.16	...
8MLN, 8MLNA	Type 316LN	S31653	0.030	2.00	0.045	0.030	1.00	16.0–18.0	10.0–13.0	2.00–3.00	0.10–0.16	...
8R, 8RA ^E	XM19	S20910	0.06	4.0–6.0	0.045	0.030	1.00	20.5–23.5	11.5–13.5	1.50–3.00	...	0.10–0.30	0.20–0.40	Vanadium, 0.10–0.30
8S, 8SA		S21800	0.10	7.0–9.0	0.060	0.030	3.5–4.5	16.0–18.0	8.0–9.0	0.08–0.18	...
8MLCuN, 8MLCuNA	S31254	S31254	0.020	1.00	0.030	0.010	0.80	19.5–20.5	17.5–18.5	6.0–6.5	0.18–0.22	Copper, 0.50–1.00
9C, 9CA	N08367	N08367	0.030	2.00	0.040	0.030	1.00	20.0–22.0	23.5–25.5	6.0–7.0	0.18–0.25	Copper 0.75
16	Chromium Molybdenum Vanadium		0.36–0.47	0.45–0.70	0.035	0.040	0.15–0.35	0.80–1.15	...	0.50–0.65	Vanadium, 0.25–0.35 Aluminum ^B 0.015

^A The intentional addition of Bi, Se, Te, and Pb is not permitted except for Grades 6F, 8F, and 8FA, in which Se is specified and required.

^B Total aluminum, soluble and insoluble.

^C Maximum, unless minimum or range is indicated.

^D Because of the degree to which sulfur segregates, product analysis for sulfur over 0.060 % max is not technologically appropriate.

^E As described in Specification A 276.



TABLE 2 Hardness Requirements

Grade and Type	Completed Nuts			Sample Nut after Treatment as in 7.1.5	
	Brinell Hardness	Rockwell Hardness		Brinell Hardness, min	Rockwell Hardness B Scale, min
		C Scale	B Scale		
1	121 min	...	70 min	121	70
2	159 to 352	...	84 min	159	84
2H	248 to 327	24 to 35	...	179	89
To 1½ in. or M36, incl	248 to 327	24 to 35	...	179	89
Over 1½ in. or M36	212 to 327	35 max	95 min	147	79
2HM and 7M	159 to 237	22 max	...	159	84
3, 4, 7, and 16	248 to 327	24 to 35	...	201	94
6 and 6F	228 to 271	20 to 28
8, 8C, 8M, 8T, 8F, 8P, 8N,	126 to 300	...	60 to 105
8MN, 8LN, 8MLN, 8MLCuN,	126 to 300	...	60 to 105
and 9C					
8A, 8CA, 8MA, 8TA,	126 to 192	...	60 to 90
8FA, 8PA, 8NA, 8MNA,	126 to 192	...	60 to 90
8LNA, 8MLNA, and	126 to 192	...	60 to 90
8MLCuNA					
8R, 8RA, 8S, and 8SA	183 to 271	B 88 to C 25
9C, 9CA	126 to 192	...	60 to 90

8.2.2 Nuts over 1 in. nominal size shall be either UNC Series Class 2B fit or 8 UN Series Class 2B fit. Unless otherwise specified, the 8 UN series shall be furnished. Metric nuts over M24 nominal size shall be coarse thread series tolerance 6H.

9. Workmanship, Finish, and Appearance

9.1 Nuts shall be free of defects and shall be good commercial finish.

9.2 If visible surface imperfections in size ¼ through 1½ in. and M6 through M36 and in any grade other than Grade 8 become a matter of issue between the manufacturer and the purchaser, the cone proof load test described in 7.3 shall be employed.

9.3 If a scale-free bright finish is required, this shall be specified on the purchase order.

10. Retests

10.1 Provisions for retests by the purchaser and his representative are specified in Supplementary Requirement S2.

11. Certification

11.1 The producer of nuts shall furnish a certification to the purchaser or his representative showing the results of the chemical analysis, macroetch examination (Carbon and Alloy Steels Only), mechanical tests, and the minimum tempering temperature for nuts of Grades 2H, 2HM, 3, 4, 6, 6F, 7, and 7M.

11.2 Certification shall also include at least the following:

11.2.1 A statement that the fasteners were manufactured, sampled, tested and inspected in accordance with the specification and any supplementary requirements or other requirements designated in the purchase order or contract and was found to meet those requirements.

11.2.2 The specification number, year date, and identification symbol.

12. Product Marking

12.1 All nuts shall bear the manufacturer's identification mark.

12.2 Nuts shall be legibly marked on one face to indicate the grade and process of the manufacturer, as presented in Table 7. Marking of wrench flats or bearing surfaces is not permitted unless agreed upon between manufacturer and purchaser. Nuts coated with zinc shall have an asterisk (*) marked after the grade symbol. Nuts coated with cadmium shall have a plus sign (+) marked after the grade symbol.

12.3 For purposes of identification marking, the manufacturer is considered the organization that certifies the fastener was manufactured, sampled, tested, and inspected in accordance with the specification and the results have been determined to meet the requirements of this specification.

13. Keywords

13.1 bolting; chemical analysis; coated; marking on fasteners; plated



TABLE 3 Proof Load Using Threaded Mandrel — Inch Series

NOTE 1—Proof loads are not design loads.

Nominal Size, in.	Threads per Inch	Stress Area in. ²	Proof Load, lbf ^A					
			Grade 1		Grades 2, 2HM, 6, 6F, 7M		Grades 2H, 3, 4, 7, 16	
			Heavy Hex ^B	Hex ^C	Heavy Hex ^D	Hex ^E	Heavy Hex ^F	Hex ^G
1/4	20	0.0316	4 130	3 820	4 770	4 300	5 570	4 770
5/16	18	0.0524	6 810	6 290	7 860	7 070	9 170	7 860
3/8	16	0.0774	10 080	9 300	11 620	10 460	13 560	11 620
7/16	14	0.1063	13 820	12 760	15 940	14 350	18 600	15 940
1/2	13	0.1419	18 450	17 030	21 280	19 160	24 830	21 280
9/16	12	0.182	23 660	21 840	27 300	24 570	31 850	27 300
5/8	11	0.226	29 380	27 120	33 900	30 510	39 550	33 900
3/4	10	0.334	43 420	40 080	50 100	45 090	58 450	50 100
7/8	9	0.462	60 060	55 440	69 300	62 370	80 850	69 300
1	8	0.606	78 780	72 720	90 900	81 810	106 000	90 900
1 1/8	8	0.790	102 700	94 800	118 500	106 700	138 200	118 500
1 1/4	8	1.000	130 000	120 000	150 000	135 000	175 000	150 000
1 3/8	8	1.233	160 200	148 000	185 000	166 500	215 800	185 000
1 1/2	8	1.492	194 000	170 040	223 800	201 400	261 100	223 800

All Types of Grade 8, Grades 9C and 9CA								
			Heavy Hex ^H		Hex ^I			
	1/4	20	0.0316	2 540	2 380			
	5/16	18	0.0524	4 190	3 930			
	3/8	16	0.0774	6 200	5 810			
	7/16	14	0.1063	8 500	7 970			
	1/2	13	0.1419	11 350	10 640			
	9/16	12	0.182	14 560	13 650			
	5/8	11	0.226	18 080	16 950			
	3/4	10	0.334	26 720	25 050			
	7/8	9	0.462	36 960	34 650			
	1	8	0.606	48 480	45 450			
	1 1/8	8	0.790	63 200	59 250			
	1 1/4	8	1.000	80 000	75 000			
	1 3/8	8	1.233	98 640	92 450			
	1 1/2	8	1.492	119 360	111 900			

^A See limit for proof load test in 7.2.2.1. The proof load for jam nuts shall be 46 % of the tabulated load.

^B Based on proof stress of 130 000 psi.

^C Based on proof stress of 120 000 psi.

^D Based on proof stress of 150 000 psi.

^E Based on proof stress of 135 000 psi.

^F Based on proof stress of 175 000 psi.

^G Based on proof stress of 150 000 psi.

^H Based on proof stress of 80 000 psi.

^I Based on proof stress of 75 000 psi.



TABLE 4 Proof Load Using Threaded Mandrel — Metric

NOTE 1—Proof loads are not design loads.

Nominal Size, mm	Threads Pitch	Stress Area mm ²	Proof Load, kN ^A					
			Grade 1		Grades 2, 2HM, 6, 6F, 7M		Grades 2H, 3, 4, 7, 16	
			Heavy Hex ^B	Hex ^C	Heavy Hex ^D	Hex ^E	Heavy Hex ^F	Hex ^G
M6	1.0	20.1	18.0	16.6	20.8	18.7	29.2	20.8
M8	1.25	36.6	32.8	30.2	37.9	34.0	44.1	37.9
M10	1.50	58.0	51.9	47.9	60.0	53.9	69.9	60.0
M12	1.75	84.3	75.5	69.5	87.3	78.4	101.6	87.3
M14	2.0	115.0	102.9	94.9	119.0	107.0	138.6	119.0
M16	2.0	157.0	140.5	129.5	162.5	146.0	189.2	162.5
M20	2.5	245.0	219.3	202.1	253.6	227.8	295.2	253.6
M22	2.5	303.0	271.2	249.9	313.6	281.8	365.1	313.6
M24	3.0	353.0	315.9	291.2	365.4	328.3	425.4	365.4
M27	3.0	459.0	411.0	378.7	475.1	426.9	553.4	475.1
M30	3.5	561.0	502.1	462.8	580.6	521.7	676.0	580.6
M36	4.0	817.0	731.2	674.0	845.6	759.8	984.5	845.6

Nominal Size, mm	Thread Pitch	All Types of Grade 8, and Grades 9C and 9CA			
		Stress Area, mm ²	Heavy Hex ^H	Hex ^I	
M6	1.0	20.1	11.1	10.4	
M8	1.25	36.6	20.1	18.8	
M10	1.50	58.0	31.9	29.9	
M12	1.75	84.3	46.4	43.4	
M14	2.0	115.0	63.3	59.2	
M16	2.0	157.0	86.4	80.9	
M20	2.5	245.0	134.8	126.2	
M22	2.5	303.0	166.7	156.0	
M24	3.0	353.0	194.2	181.8	
M27	3.0	459.0	252.5	236.4	
M30	3.5	561.0	308.6	288.9	
M36	4.0	817.0	449.4	420.8	

^A See limit for proof load test in 7.2.2.1. The proof load for jam nuts shall be 46 % of the tabulated load.

^B Based on proof stress of 895 MPa.

^C Based on proof stress of 825 MPa.

^D Based on proof stress of 1035 MPa.

^E Based on proof stress of 930 MPa.

^F Based on proof stress of 1205 MPa.

^G Based on proof stress of 1035 MPa.

^H Based on proof stress of 550 MPa.

^I Based on proof stress of 515 MPa.



A 194/A 194M – 03b

TABLE 5 Proof Load Using 120° Hardened Steel Cone — Inch^A

Nominal Size, in.	Threads per Inch	Stress Area in. ²	Proof Load, lbf					
			Grade 1		Grades 2, 2HM, 6, 6F, 7M		Grades 2H, 3, 4, 7, 16	
			Heavy Hex ^B	Hex ^C	Heavy Hex ^D	Hex ^E	Heavy Hex ^F	Hex ^D
1/4	20	0.0318	3 800	3 550	4 400	4 000	5 150	4 400
5/16	18	0.0524	6 150	5 700	7 100	6 400	8 300	7 100
3/8	16	0.0774	8 950	8 250	10 300	9 300	12 000	10 300
7/16	14	0.1063	12 000	11 100	13 850	12 450	16 150	13 850
1/2	13	0.1419	15 700	14 500	18 100	16 300	21 100	18 100
9/16	12	0.182	19 650	18 150	22 700	20 400	26 500	22 700
5/8	11	0.226	23 900	22 050	27 550	24 800	32 150	27 550
3/4	10	0.334	33 650	31 050	38 850	34 950	45 300	38 850
7/8	9	0.462	44 300	40 900	51 100	46 600	59 650	51 100
1	8	0.606	55 150	50 900	63 650	57 300	74 250	63 650
1 1/8	8	0.790	68 000	62 800	78 500	70 650	91 600	78 500
1 1/4	8	1.000	81 250	75 000	93 750	84 400	109 350	93 750
1 3/8	8	1.233	94 250	86 950	108 750	97 800	126 850	108 750
1 1/2	8	1.492	106 700	98 500	123 100	110 800	143 600	123 100

^A Based upon the following equation (this equation cannot be used for extrapolating values beyond the size ranges listed in this table):

$$CPL = (1 - 0.30D) \times f \times As$$

where:

- CPL = cone stripping proof load lbf,
- D = nominal diameter of nut, in.,
- f = minimum proof stress of nut, psi; see footnote b, c, d, e, and f,
- As = tensile stress area of nut, in.² = 0.7854 [D - 0.9743/n]², and
- n = threads per inch.

- ^B Based on proof stress of 130 000 psi.
- ^C Based on proof stress of 120 000 psi.
- ^D Based on proof stress of 150 000 psi.
- ^E Based on proof stress of 135 000 psi.
- ^F Based on proof stress of 175 000 psi.

TABLE 6 Proof Load Using 120° Hardened Steel Cone — Metric^A

Nominal Size, mm	Thread Pitch	Stress Area mm ²	Proof Load, kN					
			Grade 1		Grades 2, 2HM, 6 6F, 7M		Grades 2H, 3, 4, 7, 16	
			Heavy Hex ^B	Hex ^C	Heavy Hex ^D	Hex ^E	Heavy Hex ^F	Hex ^D
M6	1.0	20.1	16.9	15.4	19.3	17.3	22.5	19.3
M8	1.25	36.6	29.6	27.3	34.2	30.8	39.9	34.2
M10	1.50	58.0	45.7	42.1	52.8	47.5	61.5	52.8
M12	1.75	84.3	64.6	59.5	74.7	67.1	86.9	74.7
M14	2.0	115.0	85.6	78.9	99.0	88.9	115.3	99.0
M16	2.0	157.0	113.5	104.7	131.2	118.0	152.9	131.2
M20	2.5	245.0	166.6	153.6	192.7	173.2	224.4	192.7
M22	2.5	303.0	199.6	183.9	230.8	207.4	268.7	230.8
M24	3.0	353.0	224.9	207.4	260.1	233.7	302.9	260.1
M27	3.0	459.0	277.7	256.0	321.1	288.6	373.9	321.1
M30	3.5	561.0	321.3	296.2	371.6	334.0	432.6	371.6
M36	4.0	817.0	415.3	382.8	480.3	431.6	559.2	480.3

^A Based upon the following equation (this equation cannot be used for extrapolating values beyond the size ranges listed in this table):

$$CPL = (1 - 0.012D) \times f \times As \times 0.001$$

where:

- CPL = cone stripping proof load lbf [kN],
- D = nominal diameter of nut, in. [mm],
- f = minimum proof stress of nut, psi [MPa]; see footnote b, c, d, e, and f,
- As = tensile stress area of nut, mm² = 0.7854 [D - 0.9382P]², and
- n = thread pitch, mm.

- ^B Based on proof stress of 895 MPa.
- ^C Based on proof stress of 825 MPa.
- ^D Based on proof stress of 1035 MPa.
- ^E Based on proof stress of 930 MPa.
- ^F Based on proof stress of 1205 MPa.

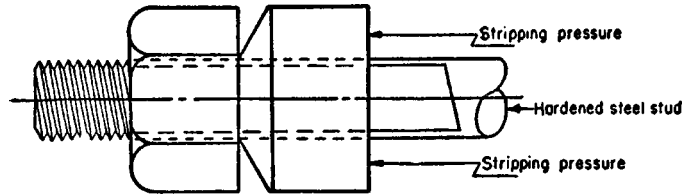

FIG. 1 Application of Hardened Steel Cone to Testing of Nuts

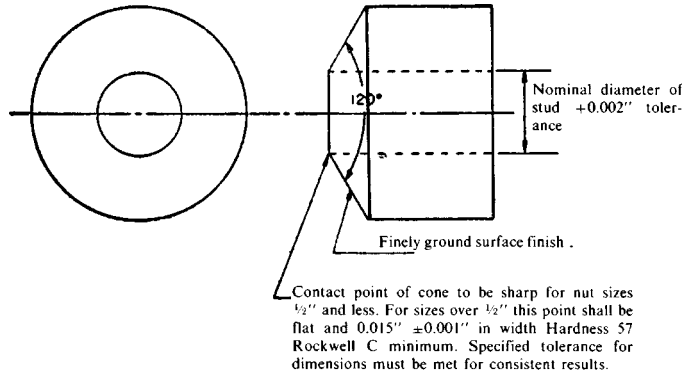

FIG. 2 Hardened Steel Cone

TABLE 7 Marking of Nuts

Grade and Type	Nuts Hot-Forged or Cold-Punched	Nuts Machined from Bar Stock	Nuts Manufactured in Accordance with 6.6
1	1	1B	...
2	2	2B	...
2H ^A	2H	2HB	...
2HM ^A	2HM	2HMB	...
3	3	3B	...
4	4	4B	...
4L ^B	4L	4BL	...
6	6	6B	...
6F	6F	6FB	...
7	7	7B	...
7L ^B	7L	7BL	...
7M ^A	7M	7MB	...
8	8	8B	8A
8C	8C	8CB	8CA
8M	8M	8MB	8MA
8T	8T	8TB	8TA
8F	8F	8FB	8FA
8P	8P	8PB	8PA
8N	8N	8NB	8NA
8MN	8MN	8MNB	8MNA
8R	8R	8RB	8RA
8S	8S	8SB	8SA
8LN	8LN	8LNB	8LNA
8MLN	8MLN	8MLNB	8MLNA
8MLCuN	8MLCuN	8MLCuNB	8MLCuNA
9C	9C	9CB	9CA
16	16	16B	

^A The letters H and M indicate heat-treated nuts (see Section 6).

^B See Supplementary Requirement S3.



SUPPLEMENTARY REQUIREMENTS

One or more of the following supplementary requirements shall be applied only when specified by the purchaser in the inquiry, contract, or order. Details of these supplementary requirements shall be agreed upon in writing by the manufacturer and purchaser. Supplementary requirements shall in no way negate any requirement of the specification itself.

S1. Strain-Hardened Austenitic Steel Nuts

S1.1 Strain hardened Grades 8, 8C, 8T, 8M, 8F, 8P, 8N, or 8MN nuts may be specified. When Supplementary Requirement S1 is invoked in the order, nuts shall be machined from cold drawn bars or shall be cold forged to shape. No subsequent heat treatment shall be performed on the nuts. Nuts made in accordance with this requirement shall be proof load tested in accordance with 7.2.2.1 and shall withstand the proof load specified in Table 8 and Table 9. For nuts requiring proof loads over 120 000 lbf or 530 kN, Supplementary Requirement S4 is invoked. The hardness limits of Table 2 do not apply to strain hardened nuts. Nuts made in accordance with this requirement shall be marked with the Grade symbol underlined.

S2. Retests by Purchaser’s Representative

S2.1 The purchaser’s representative may select two nuts per keg (200-lb unit [90-kg]) for sizes 5/8 in. and M16 and smaller, one nut per keg for sizes over 5/8 in. and M16 up to and including 1 1/2 in. and M36, and one nut per every two kegs for sizes larger than 1 1/2 in. and M36, which shall be subjected to the tests specified in Section 7.

S3. Low-Temperature Requirements for Grade 4, Grade 7 or Grade 7M Nuts

S3.1 When low-temperature requirements are specified for Grade 4 or Grade 7 nuts, the Charpy test procedures and requirements as defined in Specification A 320/A 320M for

Grade L7 shall apply. When low-temperature requirements are specified for Grade 7M nuts, the Charpy test procedures and requirements as defined in Specification A 320/A 320M for Grade L7M shall apply. Depending on the size of nuts, separate test samples of the same heat may be required and shall be processed through heat treatment with the nuts for which the test is to apply. Impact testing is not required when the bar stock or nut is smaller than 5/8 in. in diameter or 16M in diameter.

S3.2 An“ L” shall be added to the marking, as shown in Table 7, for nuts so tested.

S4. Proof Load Tests of Large Nuts

S4.1 Proof load testing of nuts requiring proof loads of over 120 000 lbf or 530 kN may be required. When specified, the test is to be performed in accordance with 7.2 to the loads required by Table 10 and Table 11. The maximum load will be based entirely on the equipment available.

S5. Control of Product by Heat Number

S5.1 When control of nuts by actual heat analysis is required and this supplementary requirement is specified, the manufacturer shall identify the completed nuts in each shipment by the actual heat number. When this supplementary requirement is specified, a certificate including the results of the actual production tests of each test lot together with the heat chemical analysis shall be furnished by the manufacturer.

TABLE 8 Proof Load Testing of Strain Hardened Nuts Using Threaded Mandrel — Inch Series

NOTE 1—Proof loads are not design loads.

Nominal Size, in.	Threads per in.	Stress Area, in. ²	Proof Load, lbf ^A			
			Grade 8M (strain hardened)	Grade 8M (strain hardened)	All Other Types of Grade 8 (strain hardened)	All Other Types of Grade 8 (strain hardened)
			Heavy Hex ^B	Hex ^C	Heavy Hex ^D	Hex ^B
1/4	20	0.0316	3 480	3 160	3 950	3 480
5/16	18	0.0523	5 760	5 240	6 550	5 760
3/8	16	0.0774	8 510	7 740	9 675	8 510
7/16	14	0.1063	11 690	10 630	13 290	11 690
1/2	13	0.1419	15 610	14 190	17 740	15 610
9/16	12	0.182	20 020	18 200	22 750	20 020
5/8	11	0.226	24 860	22 600	28 250	24 860
3/4	10	0.334	36 740	33 400	41 750	36 740
7/8	9	0.462	46 200	41 580	53 130	46 200
1	8	0.606	60 600	54 540	69 690	60 600
1 1/8	8	0.790	75 050	67 150	82 950	75 050
1 1/4	8	1.000	95 000	85 000	105 000	95 000
1 3/8	8	1.233	110 970	98 640	123 300	110 970
1 1/2	8	1.492	134 280	119 360	149 200	134 280

^A The proof load for jam nuts shall be 46 % of the tabulated value.

^B Based on proof stress of 110 000 psi up to 3/4 in.; 100 000 psi 7/8 to 1 in.; 95 000 psi 1 1/8 to 1 1/4 in.; 90 000 psi 1 1/2 to 1 3/4 in.

^C Based on proof stress of 100 000 psi up to 3/4 in.; 90 000 psi 7/8 to 1 in.; 85 000 psi 1 1/8 to 1 1/4 in.; 80 000 psi 1 1/2 to 1 3/4 in.

^D Based on proof stress of 125 000 psi up to 3/4 in.; 115 000 psi 7/8 to 1 in.; 105 000 psi 1 1/8 to 1 1/4 in.; 100 000 psi 1 1/2 to 1 3/4 in.



TABLE 9 Proof Load Testing of Strain Hardened Nuts Using Threaded Mandrel — Metric

NOTE 1—Proof loads are not design loads.

Nominal Size, mm	Thread Pitch	Stress Area, mm ²	Proof Load, kN ^A			
			Grade 8M (strain hardened)	Grade 8M (strain hardened)	All Other Types of Grade 8 (strain hardened)	All Other Types of Grade 8 (strain hardened)
			Heavy Hex ^B	Hex ^C	Heavy Hex ^D	Hex ^B
M6	1.0	20.1	15.3	13.9	17.3	15.3
M8	1.25	36.6	27.8	25.3	31.3	27.8
M10	1.50	58.0	44.1	40.0	49.9	44.1
M12	1.75	84.3	64.1	58.2	72.5	64.1
M14	2.0	115.0	87.4	79.4	98.9	87.4
M16	2.0	157.0	119.3	108.3	135.0	119.3
M20	2.5	245.0	186.2	169.0	210.9	186.2
M22	2.5	303.0	209.0	187.9	240.9	209.0
M24	3.0	353.0	243.5	218.9	280.6	243.5
M27	3.0	459.0	300.6	268.5	332.7	300.6
M30	3.5	561.0	367.5	328.2	406.7	367.5
M36	4.0	817.0	506.5	449.4	563.7	506.5

^A The proof load for jam nuts shall be 46 % of the tabulated value.

^B Based on proof stress of 760 MPa up to M20 mm; 690 MPa M22 to M24 mm; 655 MPa M27 to M30; and 620 MPa for M36.

^C Based on proof stress of 690 MPa up to M20 mm; 620 MPa M22 to M24 mm; 585 MPa M27 to M30; and 550 MPa for M36.

^D Based on proof stress of 860 MPa up to M20 mm; 795 MPa M22 to M24 mm; 725 MPa M27 to M30 mm; and 690 MPa for M36.

TABLE 10 Proof Load for Large Heavy Hex Nuts — Inch^A

Nominal Size, in.	Threads per in.	Stress Area, in. ²	Proof Load, lbf ^B		
			Grade 1 Heavy Hex	Grades 2, 6, 6F Heavy Hex	Grades 2H, 3, 4, 7, 16 Heavy Hex
1½	8	1.78	231 400	267 000	311 500
1¾	8	2.08	270 400	312 000	364 000
1⅞	8	2.41	313 300	361 500	421 800
2	8	2.77	360 100	415 500	484 800
2¼	8	3.56	462 800	534 000	623 000
2½	8	4.44	577 200	666 000	777 000
2¾	8	5.43	705 900	814 500	950 250

^A ANSI B18.2.2 in the size range over 1½ in. provides dimensions only for heavy hex nuts. Refer to 7.3.1.

^B Proof loads for nuts of larger dimensions or other thread series may be calculated by multiplying the thread stress area times the proof stress in the notes to Table 3 or Table 8. The proof load for jam nuts shall be 46 % of the tabulated load.

TABLE 11 Proof Load for Large Heavy Hex Nuts — Metric^A

Nominal Size, mm	Thread Pitch	Stress Area, mm ²	Proof Load, kN ^B		
			Grade 1 Heavy Hex	Grades 2, 6, 6F Heavy Hex	Grades 2H, 3, 4, 7, 16 Heavy Hex
M42	4.5	1120	1002.4	1159.2	1771.4
M48	5	1470	1315.7	1521.4	1771.4
M56	5.5	2030	1816.9	2101.0	2446.2
M64	6	2680	2398.6	2773.8	3229.4
M72	6	3460	3096.7	3581.1	4169.3

^A ANSI B 18.2.4.6M in the size range over M36 provides dimensions only for heavy hex nuts. Refer to 7.3.1.

^B Proof loads for nuts of larger dimensions or other thread series may be calculated by multiplying the thread stress area times the proof stress in the notes to Table 3 or Table 8. The proof load for jam nuts shall be 46 % of the tabulated load.

S6. Grain Size Requirements for Non H Grade Austenitic Steels Used Above 1000°F

S6.1 For design metal temperatures above 1000°F [540°C], the material shall have a grain size of No. 7 or coarser as

determined in accordance with Test Methods E 112. The grain size so determined shall be reported on the Certificate of Test.



APPENDIXES

(Nonmandatory Information)

X1. STRAIN HARDENING OF AUSTENITIC STEELS

X1.1 Strain hardening is the increase in strength and hardness that results from plastic deformation below the recrystallization temperature (cold work). This effect is produced in austenitic stainless steels by reducing oversized bars to the desired final size by cold drawing or other process. The degree of strain hardening achievable in any alloy is limited by its strain hardening characteristics. In addition, the amount of strain hardening that can be produced is further limited by the variables of the process, such as the total amount of cross-

section reduction, die angle and bar size. In large diameter bars, for example, plastic deformation will occur principally in the outer regions of the bar, so that the increased strength and hardness due to strain hardening is achieved predominantly near the surface of the bar. That is, the smaller the bar, the greater the penetration of strain hardening. Thus, the mechanical properties of a given strain hardened fastener are dependent not just on the alloy, but also on the size of bar from which it is machined.

X2. COATINGS AND APPLICATION LIMITS

X2.1 Use of coated fasteners at temperatures above approximately one-half the melting point (Fahrenheit or Celsius) of the coating is not recommended unless consideration is given to the potential for liquid and solid metal embrittlement, or both. The melting point of elemental zinc is approximately

780°F [415°C]. Therefore, application of zinc coated fasteners should be limited to temperatures less than 390°F [210°C]. The melting point of cadmium is approximately 600°F [320°C]. Therefore, application of cadmium coated fasteners should be limited to temperatures less than 300°F [160°C].

SUMMARY OF CHANGES

Committee A01 has identified the location of selected changes to this specification since the last issue, A 194/A 194M – 03a, which may impact the use of this specification. (Approved October 28, 2003)

- (1) Clarified Impact test requirements in S3.1.
- (2) Changed maximum hardness of Grades 2H, 3, 4, 7, and 16 in Table 2.

Committee A01 has identified the location of selected changes to this specification since the last issue, A 194/A 194M – 03, which may impact the use of this specification. (Approved May 10, 2003)

- (1) Added Grade L7M to Supplementary section S3.

ASTM International takes no position respecting the validity of any patent rights asserted in connection with any item mentioned in this standard. Users of this standard are expressly advised that determination of the validity of any such patent rights, and the risk of infringement of such rights, are entirely their own responsibility.

This standard is subject to revision at any time by the responsible technical committee and must be reviewed every five years and if not revised, either reapproved or withdrawn. Your comments are invited either for revision of this standard or for additional standards and should be addressed to ASTM International Headquarters. Your comments will receive careful consideration at a meeting of the responsible technical committee, which you may attend. If you feel that your comments have not received a fair hearing you should make your views known to the ASTM Committee on Standards, at the address shown below.

This standard is copyrighted by ASTM International, 100 Barr Harbor Drive, PO Box C700, West Conshohocken, PA 19428-2959, United States. Individual reprints (single or multiple copies) of this standard may be obtained by contacting ASTM at the above address or at 610-832-9585 (phone), 610-832-9555 (fax), or service@astm.org (e-mail); or through the ASTM website (www.astm.org).