

# Specification for Casing and Tubing

**API Specification 5CT  
Eighth Edition, July 1, 2005**

**ISO 11960:2004, Petroleum and natural gas  
industries—Steel pipes for use as casing or tubing  
for wells**

EFFECTIVE DATE: JANUARY 1, 2006





## Special Notes

API publications necessarily address problems of a general nature. With respect to particular circumstances, local, state, and federal laws and regulations should be reviewed.

API is not undertaking to meet the duties of employers, manufacturers, or suppliers to warn and properly train and equip their employees, and others exposed, concerning health and safety risks and precautions, nor undertaking their obligations under local, state, or federal laws.

Information concerning safety and health risks and proper precautions with respect to particular materials and conditions should be obtained from the employer, the manufacturer or supplier of that material, or the material safety data sheet.

Nothing contained in any API publication is to be construed as granting any right, by implication or otherwise, for the manufacture, sale, or use of any method, apparatus, or product covered by letters patent. Neither should anything contained in the publication be construed as insuring anyone against liability for infringement of letters patent.

Generally, API standards are reviewed and revised, reaffirmed, or withdrawn at least every five years. Sometimes a one-time extension of up to two years will be added to this review cycle. This publication will no longer be in effect five years after its publication date as an operative API standard or, where an extension has been granted, upon republication. Status of the publication can be ascertained from the API Standards department telephone (202) 682-8000. A catalog of API publications, programs and services is published annually and updated biannually by API, and available through Global Engineering Documents, 15 Inverness Way East, M/S C303B, Englewood, CO 80112-5776.

This document was produced under API standardization procedures that ensure appropriate notification and participation in the developmental process and is designated as an API standard. Questions concerning the interpretation of the content of this standard or comments and questions concerning the procedures under which this standard was developed should be directed in writing to the Director of the Standards department, American Petroleum Institute, 1220 L Street, N.W., Washington, D.C. 20005. Requests for permission to reproduce or translate all or any part of the material published herein should be addressed to the Director, Business Services.

API standards are published to facilitate the broad availability of proven, sound engineering and operating practices. These standards are not intended to obviate the need for applying sound engineering judgment regarding when and where these standards should be utilized. The formulation and publication of API standards is not intended in any way to inhibit anyone from using any other practices.

Any manufacturer marking equipment or materials in conformance with the marking requirements of an API standard is solely responsible for complying with all the applicable requirements of that standard. API does not represent, warrant, or guarantee that such products do in fact conform to the applicable API standard.

All rights reserved. No part of this work may be reproduced, stored in a retrieval system, or transmitted by any means, electronic, mechanical, photocopying, recording, or otherwise, without prior written permission from the publisher. Contact the Publisher, API Publishing Services, 1220 L Street, N.W., Washington, D.C. 20005.

*Copyright © 2005 American Petroleum Institute*

## API Foreword

This standard is under the jurisdiction of the API Standards Subcommittee on Tubular Goods (API C1/SC5). This API standard is identical with the English version of ISO 11960:2004. ISO 11960 was prepared by Technical Committee ISO/TC 67, Materials, equipment and offshore structures for petroleum and natural gas industries, SC 5, Casing, Tubing, and Drilling Pipe.

This standard shall become effective on the date printed on the cover but may be used voluntarily from the date of publication.

The bar notations in the margins identify parts of this standard that have been changed from the previous API edition. While efforts have been made to ensure the accuracy of the notations, the user of this standard is responsible for recognizing any differences between this and the previous edition.

API publications may be used by anyone desiring to do so. Every effort has been made by the Institute to assure the accuracy and reliability of the data contained in them; however, the Institute makes no representation, warranty, or guarantee in connection with this publication and hereby expressly disclaims any liability or responsibility for loss or damage resulting from its use or for the violation of any federal, state, or municipal regulation with which this publication may conflict.

Suggested revisions are invited and should be submitted to API, Standards department, 1220 L Street, NW, Washington, DC 20005, [standards@api.org](mailto:standards@api.org).

-----

# Contents

	Page
API Foreword .....	ii
Foreword .....	vi
Introduction .....	vii
<b>1 Scope .....</b>	<b>1</b>
<b>2 Conformance .....</b>	<b>2</b>
<b>2.1 Normative references .....</b>	<b>2</b>
<b>2.2 Units of measurement .....</b>	<b>2</b>
<b>3 Normative references .....</b>	<b>2</b>
<b>4 Terms, definitions, symbols and abbreviated terms .....</b>	<b>4</b>
<b>4.1 Terms and definitions .....</b>	<b>4</b>
<b>4.2 Symbols and abbreviated terms .....</b>	<b>8</b>
<b>5 Information to be supplied by the purchaser .....</b>	<b>9</b>
<b>5.1 Casing .....</b>	<b>9</b>
<b>5.2 Tubing .....</b>	<b>11</b>
<b>5.3 Coupling stock and accessories .....</b>	<b>12</b>
<b>6 Process of manufacture .....</b>	<b>12</b>
<b>6.1 General .....</b>	<b>12</b>
<b>6.2 Heat treatment .....</b>	<b>13</b>
<b>6.3 Straightening .....</b>	<b>13</b>
<b>6.4 Traceability .....</b>	<b>14</b>
<b>6.5 Processes requiring validation .....</b>	<b>15</b>
<b>7 Material requirements .....</b>	<b>15</b>
<b>7.1 Chemical composition .....</b>	<b>15</b>
<b>7.2 Tensile properties .....</b>	<b>15</b>
<b>7.3 Charpy V-notch test — General requirements .....</b>	<b>16</b>
<b>7.4 Charpy V-notch test — Absorbed energy requirements for coupling stock, coupling blanks and couplings .....</b>	<b>17</b>
<b>7.5 Charpy V-notch test — Absorbed energy requirements for pipe .....</b>	<b>18</b>
<b>7.6 Charpy V-notch test — Absorbed energy requirements for casing and tubing accessories .....</b>	<b>20</b>
<b>7.7 Maximum hardness .....</b>	<b>21</b>
<b>7.8 Hardness variation — Grades C90, T95 and Q125 .....</b>	<b>21</b>
<b>7.9 Process control — Grades C90, T95 and Q125 .....</b>	<b>21</b>
<b>7.10 Hardenability — Minimum percentage martensite for quenched and tempered products .....</b>	<b>21</b>
<b>7.11 Grain size — Grades C90 and T95 .....</b>	<b>22</b>
<b>7.12 Surface condition — Grades L80 9Cr and L80 13Cr .....</b>	<b>22</b>
<b>7.13 Flattening — Electric-welded pipe .....</b>	<b>22</b>
<b>7.14 Sulfide stress cracking test — Grades C90 and T95 .....</b>	<b>22</b>
<b>8 Dimensions, masses, tolerances, pipe ends and defects .....</b>	<b>24</b>
<b>8.1 Labels and sizes .....</b>	<b>24</b>
<b>8.2 Dimensions and masses .....</b>	<b>24</b>
<b>8.3 Diameter .....</b>	<b>24</b>
<b>8.4 Wall thickness .....</b>	<b>25</b>
<b>8.5 Mass .....</b>	<b>25</b>
<b>8.6 Length .....</b>	<b>25</b>
<b>8.7 Casing jointers .....</b>	<b>25</b>
<b>8.8 Height and trim of electric-weld flash .....</b>	<b>26</b>
<b>8.9 Straightness .....</b>	<b>26</b>
<b>8.10 Drift requirements .....</b>	<b>27</b>
<b>8.11 Tolerances on dimensions and masses .....</b>	<b>27</b>

8.12	Pipe ends.....	28
8.13	Defects.....	30
8.14	Coupling make-up and thread protection.....	30
9	Couplings.....	31
9.1	General requirements.....	31
9.2	Alternative grades or heat treatments.....	31
9.3	Process of manufacture — Groups 1, 2 and 3.....	32
9.4	Process of manufacture — Grade Q125.....	32
9.5	Mechanical properties.....	32
9.6	Dimensions and tolerances.....	32
9.7	Regular couplings.....	32
9.8	Special-clearance couplings — Groups 1, 2 and 3.....	33
9.9	Combination couplings.....	33
9.10	Reducing couplings — Groups 1, 2 and 3.....	33
9.11	Seal-ring couplings.....	33
9.12	Special-bevel tubing couplings — Groups 1, 2 and 3.....	33
9.13	Threading.....	33
9.14	Surface inspection.....	34
9.15	Measurement of imperfections.....	35
9.16	Repair and removal of imperfections and defects.....	35
9.17	Thread surface treatment — Grade Q125.....	35
9.18	Couplings and coupling blank protection — Grades C90, T95 and Q125.....	35
10	Inspection and testing.....	35
10.1	Test equipment.....	35
10.2	Lot definition for testing of mechanical properties.....	35
10.3	Testing of chemical composition.....	36
10.4	Tensile tests.....	37
10.5	Flattening test.....	39
10.6	Hardness test.....	40
10.7	Impact test.....	44
10.8	Grain size determination — Grades C90 and T95.....	46
10.9	Hardenability — Grades C90 and T95.....	46
10.10	Sulfide stress-cracking test — Grades C90 and T95.....	46
10.11	Metallographic evaluation — EW Grades P110 and Q125.....	46
10.12	Hydrostatic tests.....	46
10.13	Dimensional testing.....	48
10.14	Visual inspection.....	51
10.15	Non-destructive examination (NDE).....	51
11	Marking.....	58
11.1	General.....	58
11.2	Stamp marking requirements.....	59
11.3	Stencil marking requirements.....	60
11.4	Colour identification.....	60
11.5	Thread and end-finish marking — All groups.....	61
11.6	Pipe-threader marking requirements — All groups.....	61
12	Coating and protection.....	62
12.1	Coatings — All groups.....	62
12.2	Thread protectors.....	62
13	Documents.....	63
13.1	Electronic media — All groups.....	63
13.2	Certification — Groups 1, 2 and 3.....	63
13.3	Certification requirements — Grade Q125.....	63
13.4	Retention of records.....	63
14	Minimum facility requirements for various categories of manufacturer.....	64
14.1	Pipe mill.....	64
14.2	Processor.....	64
14.3	Pipe threader.....	64

<b>14.4 Coupling, pup-joint or accessory manufacturer</b> .....	<b>64</b>
<b>Annex A (normative) Supplementary requirements</b> .....	<b>66</b>
<b>Annex B (normative) Purchaser inspection</b> .....	<b>80</b>
<b>Annex C (normative) Tables in SI units</b> .....	<b>81</b>
<b>Annex D (normative) Figures in SI (USC) units</b> .....	<b>154</b>
<b>Annex E (normative) Tables in USC units</b> .....	<b>184</b>
<b>Annex F (informative) Marking instructions for API licensees</b> .....	<b>258</b>
<b>Annex G (informative) Procedures used to convert from USC units to SI units</b> .....	<b>263</b>
<b>Annex H (normative) Product Specification Levels</b> .....	<b>276</b>
<b>Annex I (normative) Requirements for thread protector design validation</b> .....	<b>283</b>
<b>Annex J (informative) Summary of Product Specification Level (PSL) requirements</b> .....	<b>287</b>
<b>Bibliography</b> .....	<b>291</b>

## Foreword

ISO (the International Organization for Standardization) is a worldwide federation of national standards bodies (ISO member bodies). The work of preparing International Standards is normally carried out through ISO technical committees. Each member body interested in a subject for which a technical committee has been established has the right to be represented on that committee. International organizations, governmental and non-governmental, in liaison with ISO, also take part in the work. ISO collaborates closely with the International Electrotechnical Commission (IEC) on all matters of electrotechnical standardization.

International Standards are drafted in accordance with the rules given in the ISO/IEC Directives, Part 2.

The main task of technical committees is to prepare International Standards. Draft International Standards adopted by the technical committees are circulated to the member bodies for voting. Publication as an International Standard requires approval by at least 75 % of the member bodies casting a vote.

Attention is drawn to the possibility that some of the elements of this document may be the subject of patent rights. ISO shall not be held responsible for identifying any or all such patent rights.

ISO 11960 was prepared by Technical Committee ISO/TC 67, *Materials, equipment and offshore structures for petroleum, petrochemical and natural gas industries*, Subcommittee SC 5, *Casing, tubing and drill pipe*.

This third edition cancels and replaces the second edition (ISO 11960:2001), which has been technically revised. It also incorporates the Technical Corrigendum ISO 11960:2001/Cor.1:2002.

It is the intent of TC 67 that the second and third editions of ISO 11960 both be applicable, at the option of the purchaser (as defined in 4.1.35), for a period of six months from the first day of the calendar quarter immediately following the date of publication of this third edition, after which period the second edition will no longer be applicable.



## Introduction

This International Standard is based on API 5CT (Specification for Casing and Tubing).

Users of this International Standard should be aware that further or differing requirements may be needed for individual applications. This International Standard is not intended to inhibit a vendor from offering, or the purchaser from accepting, alternative equipment or engineering solutions for the individual application. This may be particularly applicable where there is innovative or developing technology. Where an alternative is offered, the vendor should identify any variations from this International Standard and provide details.

This International Standard includes requirements of various nature. These are identified by the use of certain verbal forms:

- SHALL is used to indicate that a provision is MANDATORY;
- SHOULD is used to indicate that a provision is not mandatory, but RECOMMENDED as good practice;
- MAY is used to indicate that a provision is OPTIONAL.

11

# Petroleum and natural gas industries — Steel pipes for use as casing or tubing for wells

## 1 Scope

**1.1** This International Standard specifies the technical delivery conditions for steel pipes (casing, tubing, plain-end casing liners and pup joints), coupling stock and accessories and establishes requirements for three Product Specification Levels (PSL-1, PSL-2, PSL-3). The requirements for PSL-1 are the basis of this International Standard. The requirements that define different levels of standard technical requirements for PSL-2 and PSL-3, for all Grades except H-40 and L-80 9Cr, are contained in Annex H.

For pipes covered by this International Standard, the sizes, masses and wall thicknesses as well as grades and applicable end-finishes are listed in Tables C.1 to C.3 and Tables E.1 to E.3.

By agreement between the purchaser and manufacturer, this International Standard can also be applied to other plain-end pipe sizes and wall thicknesses.

This International Standard is applicable to the following connections in accordance with API Spec 5B:

- short round thread casing (STC);
- long round thread casing (LC);
- buttress thread casing (BC);
- extreme-line casing (XC);
- non-upset tubing (NU);
- external upset tubing (EU);
- integral joint tubing (IJ).

For such connections, this International Standard specifies the technical delivery conditions for couplings and thread protection. Supplementary requirements that may optionally be agreed for enhanced leak resistance connections are given in Annex A.11 (SR22).

This International Standard can also be applied to tubulars with connections not covered by ISO/API standards.

**1.2** The four groups of products to which this International Standard is applicable include the following grades of pipe:

- Group 1: All casing and tubing in Grades H, J, K and N;
- Group 2: All casing and tubing in Grades C, L, M and T;
- Group 3: All casing and tubing in Grade P;
- Group 4: All casing in Grade Q.

**1.3** Casing sizes larger than Label 1: 4-1/2 but smaller than Label 1: 10-3/4 may be specified by the purchaser to be used in tubing service, see Tables C.1, C.24, C.30 and C.31 or Tables E.1, E.24, E.30 and E.31.

**1.4** Supplementary requirements that may optionally be agreed between purchaser and manufacturer for non-destructive examination, coupling blanks, upset casing, electric-welded casing, impact testing, seal ring couplings and certificates are given in Annex A.

**1.5** This International Standard is not applicable to threading requirements.

**NOTE** Dimensional requirements on threads and thread gauges, stipulations on gauging practice, gauge specifications, as well as instruments and methods for inspection of threads are given in API Spec 5B.

## 2 Conformance

### 2.1 Normative references

In the interests of world-wide application of this International Standard, ISO/TC 67 has decided, after detailed technical analysis, that certain of the normative documents listed in Clause 3 and prepared by ISO/TC 67 or other ISO Technical Committee are interchangeable in the context of the relevant requirement with the relevant document prepared by the American Petroleum Institute (API), the American Society for Testing and Materials (ASTM) or the American National Standards Institute (ANSI). These latter documents are cited in the running text following the ISO reference and preceded by “or”, for example “ISO XXXX or API YYYY”. Application of an alternative normative document cited in this manner will lead to technical results different from the use of the preceding ISO reference. However, both results are acceptable and these documents are thus considered interchangeable in practice.

### 2.2 Units of measurement

In this International Standard, data are expressed in both the International System (SI) of units and the United States Customary (USC) system of units. For a specific order item, it is intended that only one system of units be used, without combining data expressed in the other system.

Products manufactured to specifications expressed in either of these unit systems shall be considered equivalent and totally interchangeable. Consequently, compliance with the requirements of this International Standard as expressed in one system provides compliance with requirements expressed in the other system.

For data expressed in the SI, a comma is used as the decimal separator and a space as the thousands separator. For data expressed in the USC system, a dot (on the line) is used as the decimal separator and a space as the thousands separator.

In the text, data in SI units are followed by data in USC units in parentheses.

Separate tables for data expressed in SI units and USC units are given in Annex C and Annex E respectively.

Figures are contained in Annex D and express data in both SI and USC units.

## 3 Normative references

The following referenced documents are indispensable for the application of this document. For dated references, only the edition cited applies. For undated references, the latest edition of the referenced document (including any amendments) applies.

ISO 31-0, *Quantities and units — Part 0: General principles*

ISO 643, *Steels — Micrographic determination of the apparent grain size*

ISO 6506-1, *Metallic materials — Brinell hardness test — Part 1: Test method*

ISO 6508-1, *Metallic materials — Rockwell hardness test — Part 1: Test method (Scales A, B, C, D, E, F, G, H, K, N, T)*

ISO 6892, *Metallic materials — Tensile testing at ambient temperature*

ISO 7500-1, *Metallic materials — Verification of static uniaxial testing machines — Part 1: Tension/compression testing machines — Verification and calibration of the force-measuring system*

ISO 8501-1, *Preparation of steel substrates before application of paints and related products — Visual assessment of surface cleanliness — Part 1: Rust grades and preparation grades of uncoated steel substrates and of steel substrates after overall removal of previous coatings*

ISO 9303, *Seamless and welded (except submerged arc-welded) steel tubes for pressure purposes — Full peripheral ultrasonic testing for the detection of longitudinal imperfections*

ISO 9304, *Seamless and welded (except submerged arc-welded) steel tubes for pressure purposes — Eddy current testing for the detection of imperfections*

ISO 9305, *Seamless steel tubes for pressure purposes — Full peripheral ultrasonic testing for the detection of transverse imperfections*

ISO 9402, *Seamless and welded (except submerged arc-welded) steel tubes for pressure purposes — Full peripheral magnetic transducer/flux leakage testing of ferromagnetic steel tubes for the detection of longitudinal imperfections*

ISO 9598, *Seamless steel tubes for pressure purposes — Full peripheral magnetic transducer/flux leakage testing of ferromagnetic steel tubes for the detection of transverse imperfections*

ISO 9764, *Electric resistance and induction welded steel tubes for pressure purposes — Ultrasonic testing of the weld seam for the detection of longitudinal imperfections*

ISO/TR 9769, *Steel and iron — Review of available methods of analysis*

ISO 10400, *Petroleum and natural gas industries — Formulae and calculation for casing, tubing, drill pipe and line pipe properties*

ISO 11484, *Steel tubes for pressure purposes — Qualification and certification of non-destructive testing (NDT) personnel*

ISO 13665, *Seamless and welded steel tubes for pressure purposes — Magnetic particle inspection of the tube body for the detection of surface imperfections*

ISO 13678, *Petroleum and natural gas industries — Evaluation and testing of thread compounds for use with casing, tubing and line pipe*

ANSI-NACE TM0177:1996, *Laboratory testing of metals for resistance to sulfide stress cracking at ambient temperature in H<sub>2</sub>S environment*

API Bull 5C2, *Bulletin on performance properties of casing, tubing and drill pipe*

API Bull 5C3, *Bulletin on formulas and calculations for casing, tubing, drill pipe and line pipe properties (plus Supplement 1)*

API Spec 5B, *Specification for threading, gauging and thread inspection of casing, tubing and line pipe threads*

API Std 5T1, *Imperfection terminology*

ASNT SNT-TC-1A:1984, *Recommended practice, personnel qualification and certification in non destructive testing*

ASTM A370, *Standard test methods and definitions for mechanical testing of steel products*

ASTM A751, *Standard test methods, practices and terminology for chemical analysis of steel products*

ASTM A941, *Terminology relating to steel, stainless steel, related alloys and ferroalloys*

ASTM B117, *Standard practice for operating salt spray (fog) apparatus*

ASTM E4, *Standard practices for force verification of testing machines*

ASTM E10, *Standard test method for Brinell hardness of metallic materials*

ASTM E18, *Standard test methods for Rockwell hardness and Rockwell superficial hardness of metallic materials*

ASTM E23, *Standard test methods for notched bar impact testing of metallic materials*

ASTM E29, *Standard practice for using significant digits in test data to determine conformance with specifications*

ASTM E83, *Standard practice for verification and classification of extensometer system*

ASTM E112, *Standard test methods for determining average grain size*

ASTM E213, *Standard practice for ultrasonic examination of metal pipe and tubing*

ASTM E273, *Standard practice for ultrasonic examination of the weld zone of welded pipe and tubing*

ASTM E309, *Standard practice for eddy-current examination of steel tubular products using magnetic saturation*

ASTM E570, *Standard practice for flux leakage examination of ferromagnetic steel tubular products*

ASTM E709, *Standard guide for magnetic particle examination*

IADC/SPE 11396, B.A. Dale, M.C. Moyer, T.W. Sampson, *A Test Program for the Evaluation of Oilfield Thread Protectors*, IADC/SPE Drilling Conference, New Orleans, LA, 20-23 February 1983

MIL-STD-810c, *Military Environmental Test Methods*, March 10, 1975

## 4 Terms, definitions, symbols and abbreviated terms

### 4.1 Terms and definitions

For the purposes of this document, the terms and definitions in ASTM A941 for heat treatment operations and the following apply.

#### 4.1.1

##### **accessory material**

seamless standard casing or tubing, or seamless thick-wall tubes or mechanical tubes, or bar stock or hot forgings used for the manufacture of accessories

#### 4.1.2

##### **API threads**

threads as specified in API Spec 5B

**4.1.3**

**carload**

quantity of pipe loaded on a railway car for shipment from the pipe-making facilities

**4.1.4**

**casing**

pipe run from the surface and intended to line the walls of a drilled well

**4.1.5**

**casing and tubing accessory**

one-piece tubular section used in a pipe string to provide mechanical and pressure integrity within the pipe string and facilitate the performance of some other function required of that pipe string

EXAMPLES Crossover connectors, swages, nipples, flow couplings, blast joints, etc.

NOTE Accessories exclude the other tubular products specifically defined in this International Standard or products included in other ISO (API) specifications.

**4.1.6**

**connection**

threaded assembly of tubular components

**4.1.7**

**controlled cooling**

cooling from an elevated temperature in a pre-determined manner to avoid hardening, cracking or internal damage, or to produce a desired microstructure or mechanical properties

**4.1.8**

**coupling**

internally threaded cylinder for joining two lengths of threaded pipe

**4.1.9**

**coupling blank**

unthreaded material used to produce an individual coupling

**4.1.10**

**coupling stock**

seamless thick-wall tube or mechanical tube used for the manufacture of coupling blanks

**4.1.11**

**defect**

imperfection of sufficient magnitude to warrant rejection of the product based on criteria defined in this International Standard

**4.1.12**

**electric-welded pipe**

pipe having one longitudinal seam formed by electric-resistance or electric-induction welding, without the addition of filler metal, wherein the edges to be welded are mechanically pressed together and the heat for welding is generated by the resistance to flow of electric current

**4.1.13**

**handling tight**

sufficiently tight that the coupling cannot be removed except by the use of a wrench

**4.1.14**

**heat**

metal produced by a single cycle of a batch melting process

**4.1.15**

**heat analysis**

chemical analysis representative of a heat as reported by the metal producer

**4.1.16**

**imperfection**

discontinuity in the product wall or on the product surface that can be detected by a NDE method included in Table C.62 or Table E.62 of this International Standard

**4.1.17**

**inspection**

process of measuring, examining, testing, gauging or otherwise comparing a unit of product with the applicable requirements

**4.1.18**

**inspection lot**

definite quantity of product manufactured under conditions that are considered uniform for the attribute to be inspected

**4.1.19**

**inspection lot sample**

one or more units of product selected from an inspection lot to represent that inspection lot

**4.1.20**

**inspection lot size**

number of units of product in an inspection lot

**4.1.21**

**interrupted quenching**

quenching in which the pipe being quenched is removed from the quenching medium while the pipe is at a temperature substantially higher than that of the quenching medium

**4.1.22**

**label 1**

dimensionless designation for the size or specified outside diameter that may be used when ordering pipe

**4.1.23**

**label 2**

dimensionless designation for the mass per unit length that may be used when ordering pipe

**4.1.24**

**length**

piece of pipe that may be plain-end, threaded, or threaded and coupled, that is in accordance with the range requirements in Table C.30 or Table E.30 of this International Standard

**4.1.25**

**linear imperfection**

imperfection which includes, but is not limited to, seams, laps, cracks, plug scores, cuts and gouges

NOTE See API Std 5T1.

**4.1.26**

**manufacturer**

one or more of the following, depending on the context: pipe mill; processor; threader; coupling manufacturer, pup-joint manufacturer; accessory manufacturer

NOTE See Clause 14.



**4.1.27**

**non-linear imperfection**

imperfection which includes, but is not limited to, pits and round-bottom die stamping

NOTE See API Std 5T1.

**4.1.28**

**pipe**

casing, tubing, plain-end casing liners and pup joints as a group

**4.1.29**

**pipe mill**

firm, company or corporation that operates pipe-making facilities

**4.1.30**

**plain-end casing liner**

casing provided unthreaded and with a wall thickness often greater than that specified for J55

**4.1.31**

**processor**

firm, company or corporation that operates facilities capable of heat-treating pipe made by a pipe mill

**4.1.32**

**product**

pipe, coupling, accessory, coupling stock or coupling blank, either individually or collectively as applicable

**4.1.33**

**pup joint**

casing, tubing or plain-end casing liner of length shorter than Range 1

**4.1.34**

**pup-joint material**

standard casing or tubing, or thick-wall tubes or mechanical tubes, or bar stock used for the manufacture of pup joints

**4.1.35**

**purchaser**

party responsible for both the definition of requirements for a product order and for payment for that order

**4.1.36**

**quench crack**

crack in steel resulting from stresses produced during the transformation from austenite to martensite

NOTE This transformation is accompanied by an increase in volume.

**4.1.37**

**seamless pipe**

wrought steel tubular product made without a weld seam

NOTE It is manufactured by hot-working steel, and if necessary, by subsequently cold-working or heat-treating, or a combination of these operations, to produce the desired shape, dimensions and properties.

**4.1.38**

**skelp**

hot-rolled steel strip used for manufacturing EW pipe

**4.1.39**

**special end-finish**

threads with thread form and features, manufacturing specifications, dimensions, connection make-up and performance properties which are beyond the scope of this International Standard

**4.1.40****thread protector**

cap or insert used to protect threads and seals during handling, transportation and storage

**4.1.41****tubing**

pipe placed within a well and serving to produce well fluids or to inject fluids

**4.1.42****upper critical temperature**

$A_{r3}$

temperature at which austenite begins to transform to ferrite during cooling

**4.2 Symbols and abbreviated terms**

BC	buttness thread casing connection
$C_V$	Charpy V-notch impact test minimum absorbed energy
CVN	Charpy V-notch
$D$	specified outside diameter for pipe
$d$	calculated inside diameter
EMI	electromagnetic inspection
EU	external upset tubing connection
EW	electric-welded process
FBH	flat-bottomed hole
HBW	Brinell hardness, when testing with a tungsten carbide ball
HRC	Rockwell hardness C-scale
ID	inside diameter
IJ	integral joint tubing connection
$k$	a constant used in the calculation of elongation
LC	long round thread casing connection
N	⟨heat-treat process⟩ full-length normalized
N&T	normalized and tempered
NDE	non-destructive examination
NU	non-upset tubing connection
OD	outside diameter
PSL	product specification level
Q	quenched and tempered
S	seamless process (when not referencing the chemical element sulfur)

Sc	minimum acceptable result of the ANSI-NACE TM0177:1996 Method B test
SCC	special clearance coupling
SSC	sulfide stress cracking
STC	short round thread casing connection
$t$	specified wall thickness
T&C	threaded and coupled
USC	United States customary (units)
UT	ultrasonic testing
$W$	specified outside diameter for couplings with API threads other than special clearance couplings
$W_c$	specified outside diameter of special clearance couplings with API threads
XC	extreme line casing connection
$YS_{max}$	specified maximum yield strength
$YS_{min}$	specified minimum yield strength

## 5 Information to be supplied by the purchaser

### 5.1 Casing

**5.1.1** When enquiring or placing orders for pipe to be manufactured in accordance with this International Standard, the purchaser shall specify the following:

Requirement	Reference
Standard	ISO 11960 or API 5CT
Quantity	
Type of pipe or couplings	
Casing:	
Threaded or plain-end	8.12
Type of connection: round (short or long), buttress, extreme-line threads, or other connection	8.12, Table C.1 or Table E.1
With or without couplings	8.12
Special clearance couplings	9.8, Tables C.1, C.36 or Tables E.1, E.36
Liners:	8.12.1, Table C.2 or Table E.2
Label 1 or specified outside diameter	Tables C.1, C.2 or Tables E.1, E.2
Label 2 or specified mass or wall thickness	Tables C.1, C.2 or Tables E.1, E.2
Grade and type where applicable	Tables C.1, C.2, C.5 or Tables E.1, E.2, E.5
Range length	8.6, Table C.30 or Table E.30
Seamless or electric-welded	6.1, Table C.4 or Table E.4
Critical thickness for special end-finish couplings, stock or blanks	7.6.6
Critical thickness for special end-finish accessories	7.6.6
Wall thickness verification of special end-finish accessories	10.13.4
Delivery date and shipping instructions	
Inspection by purchaser	Annex B

**5.1.2** The purchaser shall also state on the purchase agreement the requirements, where applicable, concerning the following stipulations, which are at the purchaser's option:

<b>Requirement</b>	<b>Reference</b>
Heat treatment	6.2
Lower alternative impact test temperature	7.3.7
Casing jointers	8.7
Alternative drifting requirements	8.10
Casing with couplings detached	8.14
Coupling make-up (other than power-tight)	8.14
Coupling blanks	9.2, A.4 (SR9)
Seal ring couplings	9.11, A.8 (SR13)
Heat and supplementary analyses	10.3
Additional markings	11
Pipe coatings	12.1
Material certification	13.2, A.9 (SR15)
PSL 2 or 3	Annex H

**5.1.3** The following may be agreed between purchaser and manufacturer:

<b>Requirement</b>	<b>Reference</b>
Cold rotary straightening - Grade Q125	6.3.5
Statistical impact testing	7.3.8, A.7 (SR12)
Impact of Group 1 non-heat-treated pipe	7.5.1, A.10 (SR16)
Sulfide stress cracking test - Grades C90 and T95	7.14
Length of accessories	8.6
Thread and storage compound	8.14
Waiving NDE of Group 1 couplings in Grades H40, J55 and K55	9.14.3
Coupling thread plating - Grade Q125 only	9.17
Additional hardness testing - Grades M65 and L80	10.6.2
Additional hardness testing - Grades C90 and T95	10.6.2
Reduced section tensile specimens – Grade Q125	10.4.6
Hydrostatic pressure test for handling-tight make-up, accessories and Group 4 pup-joints	10.12.2
Alternative hydrostatic test pressures	10.12.3
Plain-end Grade Q125 casing hydrostatic testing	10.12.2
Non-destructive examination	10.15, A.2 (SR1), A.3 (SR2), A.5 (SR10) and A.6 (SR11)
Marking requirements	11.1
Thread protectors	12.2
Coupling blanks – Grade Q125 only	A.4 (SR9)
Upset casing – Grade Q125 only	A.5 (SR10)
Electric-weld casing – Grades P110 and Q125	A.6 (SR11)
Alternative <i>F</i> factor in SR 12 – Grade Q125	A.7 (SR12.2)
Special end-finish for casing, couplings, pup joints or accessories	8.12.8, 9.13.2
Quality assurance requirements	
Special size and wall thickness	8.2
Enhanced leak resistance LTC connections	A.11 (SR22)

## 5.2 Tubing

**5.2.1** When enquiring or placing orders for pipe to be manufactured in accordance with this International Standard, the purchaser shall specify the following:

<b>Requirement</b>	<b>Reference</b>
Standard	ISO 11960 or API 5CT
Quantity	
Type of pipe or couplings	
Tubing:	
Non-upset, external-upset or integral joint	Table C.3 or Table E.3
Threaded, plain-end, or other connection	8.12
With or without couplings	8.12
Special bevel couplings	9.12, Tables C.3, C.37 and C.38 or Tables E.3, E.37 and E.38
Special clearance couplings	9.8, Tables C.3, C.38 or Tables E.3 and E.38
Label 1 or specified outside diameter	Table C.3 or Table E.3
Label 2 or specified mass or wall thickness	Table C.3 or Table E.3
Grade and type, where applicable	Table C.3 or Table E.3, Table C.5 or Table E.5
Range length	8.6, Table C.30 or Table E.30
Seamless or electric-welded	6.1, Table C.4 or Table E.4
Critical thickness for special end-finish couplings, stock or blanks	7.4.6
Critical thickness for accessory material	7.6.6
Wall thickness verification of special end-finish accessories	10.13.4
Delivery date and shipping instructions	
Inspection by purchaser	Annex B

**5.2.2** The purchaser shall also state on the purchase agreement the requirements, where applicable, concerning the following stipulations, which are at the purchaser's option:

<b>Requirement</b>	<b>Reference</b>
Heat treatment	6.2
Upset length — Standard or extended	8.11.6
Rounded nose	8.12.4
Coupling make-up (other than power-tight)	8.14
Tubing with couplings detached	8.14
Seal ring couplings	9.11, A.8 (SR13)
Heat and supplementary analyses	10.3
Additional markings	11
Pipe coatings	12.1
Material certification	13.2, A.9 (SR15)
PSL 2 or 3	Annex H

**5.2.3** The following may be agreed between purchaser and manufacturer:

<b>Requirement</b>	<b>Reference</b>
Statistical impact testing	7.3.8, A.7 (SR12)
Impact testing of Group 1 pipe	7.5.1, A.10 (SR16)
Sulfide stress cracking test — Grades C90 and T95	7.14
Length of accessories	8.6
Thread and storage compound	8.14
Special end-finish for tubing, couplings or accessories	8.12.8, 9.13.3
Waiving NDE of Group 1 couplings in Grades H40, J55 and K55	9.14.3
Additional hardness testing — Grades M65 and L80	10.6.2
Additional hardness testing — Grades C90 and T95	10.6.2

Hydrostatic pressure test for handling-tight make-up and pup joints	10.12.2
Alternative hydrostatic test pressures	10.12.3
Non-destructive examination	10.15, A.2 (SR1), A.3 (SR2), A.5 (SR10) and A.6 (SR11)
Marking requirements	11.1
Thread protectors	12.2
Electric-weld tubing — Grade P110	A.6 (SR11)
Special end-finish tubing, couplings, pup joints and accessories	8.12.8, 9.13.3
Quality assurance requirements	
Special size and wall thickness	8.2
Casing used for tubing	8.2, Table C.30 or Table E.30

### 5.3 Coupling stock and accessories

**5.3.1** When enquiring or placing orders for coupling stock or accessories to be manufactured in accordance with this International Standard, the purchaser shall specify the following:

Requirement	Reference
Standard	ISO 11960 or API 5CT
Quantity	
Outside diameter and tolerances	
Wall thickness and tolerances	
Straightness tolerance	
Length	
Grade, type	Tables C.4 & C.5 or Tables E.4 & E.5
Impact requirements or critical thickness	7.4
Inspection by purchaser	Annex B
Delivery date and shipping instructions	

**5.3.2** The purchaser shall also state on the purchase agreement the requirements, where applicable, concerning the following stipulations, which are at the purchaser's option:

Requirement	Reference
Heat treatment	6.2
Heat and supplementary analyses	10.3
Additional markings	11
Material certification	13.2, 13.3, A.9 (SR15)
Product Specification Level (PSL-2 or PSL-3)	Annex H

## 6 Process of manufacture

### 6.1 General

The various grades and groups of pipe furnished to this International Standard shall be made to a fine-grain practice. Steel made to a fine-grain practice contains one or more grain-refining elements, such as aluminium, niobium (columbium), vanadium or titanium in amounts intended to result in the steel having a fine austenitic grain size.

Pipe furnished to this International Standard shall be made by the seamless or electric-weld process as shown in Table C.4 or Table E.4 and as specified on the purchase agreement. Pup joints shall be made from the materials listed in 4.1.34. Material for couplings and coupling stock shall be manufactured by the seamless process. Cold-drawn tubular products without appropriate heat treatment are not acceptable.

Casing and tubing accessories shall be seamless and made from the materials listed in 4.1.1.

Electric-welded Grade P110 pipe and Grade Q125 casing shall be provided only when the supplementary requirement in A.5 (SR11) is specified on the purchase agreement.

Grade Q125 upset casing shall be provided only when the supplementary requirement in A.5 (SR10) is specified on the purchase agreement.

## 6.2 Heat treatment

### 6.2.1 General

Product shall be heat-treated in accordance with a documented procedure as stipulated in Table C.4 or Table E.4 for the particular grade and type specified on the purchase agreement. Heat-treated upset pipe shall be heat-treated full length after upsetting. Product requiring heat treatment shall be heat-treated the full length. Individually heat-treated coupling blanks are acceptable. All pipe processed through a hot-stretch mill (i.e. stretch-reduced) shall be considered normalized, provided the exit temperature is above the upper critical temperature ( $A_{r3}$ ) for the steel being processed and the pipe is air-cooled.

The weld seam of electric-welded pipe shall be heat-treated after welding to a minimum temperature of 540 °C (1 000 °F) or processed in such a manner that no untempered martensite remains.

### 6.2.2 Group 1

Grade N80 Type 1 product shall be normalized or, at the manufacturer's option, shall be normalized and tempered. Grade N80Q product shall be quenched and tempered (including the interrupted quenching followed by controlled cooling method) full length. Grades J55 and K55 casing and Grade J55 tubing shall be heat-treated if so specified on the purchase agreement.

Additional requirements for PSL-2 and PSL-3 products are specified in Annex H.

### 6.2.3 Group 2

When requested by the purchaser, the manufacturer shall produce evidence to show that the tempering practice will result in the pipe attaining the minimum tempering temperature.

Grade L80 13Cr may be subject to embrittlement when tempered below 620 °C (1 150 °F). When all product meets the requirements in 7.3, 7.4.5, 7.5.3 and 10.7, no further precautions are necessary.

NOTE In this International Standard when the symbol L80 is used alone it covers Grades L80 Type 1, L80 9Cr and L80 13Cr.

### 6.2.4 Groups 3 and 4

Product furnished to this International Standard shall be quenched and tempered.

## 6.3 Straightening

### 6.3.1 Groups 1 and 3

No specific methods are required.

Additional requirements for PSL-2 and PSL-3 products are specified in Annex H.

### 6.3.2 Grades M65 and L80

Grades M65 and L80 shall not be subjected to cold working after the final heat treatment, except for that which is incidental to normal straightening operations. Grades M65 and L80 pipe rotary-straightened at

temperatures less than 480 °C (900 °F) shall not contain roll marks that exceed the maximum hardness specified in Table C.6 or Table E.6; however:

- roll marks that are not detectable by feel and have no measurable surface deformation are acceptable without further evaluation;
- roll marks that are not more severe than those previously evaluated and verified by the manufacturer in a documented procedure not to exceed the maximum hardness specified in Table C.6 or Table E.6 are acceptable without further evaluation;
- pipe with severe roll marks shall be either rejected or stress-relieved at 480 °C (900 °F) minimum.

### 6.3.3 Grade C95

Grade C95 pipe shall be subjected to no tensile or expansion cold-working, except that which is incidental to normal straightening operations, and to no more than 3 % compressive cold-working, after the final tempering operation.

| Additional requirements for PSL-2 and PSL-3 products are specified in Annex H.

### 6.3.4 Grades C90 and T95

Grades C90 and T95 pipe may be subjected to cold rotary-straightening if, subsequent to the cold rotary-straightening operation, the pipe is heated to a minimum temperature of 480 °C (900 °F) for stress-relieving. When necessary, light gag-straightening for Grades C90 and T95 shall be permitted.

| Additional requirements for PSL-2 and PSL-3 products are specified in Annex H.

### 6.3.5 Grade Q125

Gag-press straightening or hot rotary-straightening at 400 °C (750 °F) minimum at the end of rotary-straightening is acceptable (unless a higher minimum temperature is specified on the purchase agreement). If hot rotary-straightening is not possible, the pipe may be cold rotary-straightened provided it is then stress-relieved at 510 °C (950 °F) or higher. Pipe may be cold rotary-straightened without subsequent stress-relieving only by agreement between purchaser and manufacturer.

## 6.4 Traceability

### 6.4.1 General

The manufacturer shall establish and follow procedures for maintaining heat and/or lot identity until all required heat and/or lot tests are performed and conformance with specification requirements has been shown.

### 6.4.2 Serialization of Grades C90, T95 and Q125

The serial number shall be marked on products as specified below. It is the responsibility of the manufacturer to maintain the identification of material until it is received by the purchaser.

Each length of pipe shall be uniquely numbered so that test data can be related to individual lengths. In addition, when supplementary requirement A.7 (SR12) is specified, the number shall identify the sequence in which the lengths were tempered in order to allow re-test in accordance with A.7.3 (SR12.3).

| Each length of coupling stock, coupling, pup joint or accessory material shall be uniquely numbered so that test data can be related to individual lengths. When cut from material that has been heat-treated full length, the pieces shall be marked with the serial number of the full length piece. When heat-treated in coupling blank or individual lengths, each heat-treat lot (see 10.2.3) shall be uniquely numbered. Additionally, when coupling,



pup joint or accessory materials in coupling blanks or individual lengths are heat-treated as a unit in a continuous process-run, the pieces within the lot shall be sequentially numbered in the order in which they are heat-treated.

## 6.5 Processes requiring validation

Final operations performed during pipe manufacturing that affect attribute compliance as required in this International Standard (except chemical composition and dimensions) shall have their processes validated.

Those processes requiring validation are:

- for seamless, as-rolled pipe: final reheating practice and hot sizing or stretch-reducing. If applicable, upsetting, cold finishing;
- for seamless, heat-treated pipe: heat treatment;
- for electric-welded, as-rolled pipe: sizing and seam welding. If applicable, seam heat treatment and upsetting;
- for electric-welded, heat-treated pipe: seam welding and full-body heat treatment.

## 7 Material requirements

### 7.1 Chemical composition

Product shall conform to the requirements specified in Table C.5 or Table E.5 for the grade and type specified.

Additional requirements for PSL-2 and PSL-3 products are specified in Annex H.

### 7.2 Tensile properties

#### 7.2.1 General

Product shall conform to the tensile requirements specified in Table C.6 or Table E.6.

The tensile properties of upset casing and tubing, except elongation of the upset ends, shall comply with the requirements given for the pipe body. In case of dispute, the properties (except elongation) of the upset shall be determined from a tensile test specimen cut from the upset. A record of such tests shall be available to the purchaser.

#### 7.2.2 Elongation — All groups

The minimum elongation shall be that determined by the following equation:

$$e = k \times \frac{A^{0,2}}{U^{0,9}}$$

where

$e$  is the minimum gauge length extension in 50,8 mm (2.0 in), expressed in percent, rounded to the nearest 0,5 % below 10 % and to the nearest unit percent for 10 % and larger;

$k$  is a constant: 1 944 (625 000);

- A* is the cross-sectional area of the tensile test specimen, expressed in square millimetres (square inches), based on specified outside diameter or nominal specimen width and specified wall thickness, rounded to the nearest 10 mm<sup>2</sup> (0.01 in<sup>2</sup>), or 490 mm<sup>2</sup> (0.75 in<sup>2</sup>) whichever is smaller;
- U* is the minimum specified tensile strength, in megapascals (pounds per square inch).

The minimum elongation for both round-bar tensile specimens [8,9 mm (0.350 in) diameter with 35,6 mm (1.40 in) gauge length and 12,7 mm (0.500 in) diameter with 50,8 mm (2.0 in) gauge length] shall be determined using an area *A* of 130 mm<sup>2</sup> (0.20 in<sup>2</sup>).

Table C.7 or Table E.7 gives minimum elongation values for various sizes of tensile specimens and for various grades.

### 7.2.3 Yield strength

The yield strength shall be the tensile stress required to produce the elongation under load specified in Table C.6 or Table E.6 as determined by an extensometer.

Additional requirements for PSL-3 products are specified in Annex H.

## 7.3 Charpy V-notch test — General requirements

### 7.3.1 Evaluation of test results

A test shall consist of a set of three specimens taken from one location from a single tubular product length. The average value of the three impact specimens shall equal or exceed the absorbed energy requirement specified in 7.4, 7.5 and 7.6. In addition, not more than one impact specimen shall exhibit an absorbed energy below the absorbed energy requirement, and in no case shall an individual impact specimen exhibit an absorbed energy below two-thirds of the absorbed energy requirement.

Additional requirements for PSL-2 and PSL-3 products are specified in Annex H.

### 7.3.2 Critical thickness

The absorbed energy requirements are based on the critical thickness. The critical thickness for couplings with API threads is the thickness at the root of the thread at the middle of the coupling, based on the specified coupling diameter and the specified thread dimensions. The critical thickness for all couplings with API threads is provided in Table C.8 or Table E.8. For pipe, the critical thickness is the specified wall thickness. For other applications, the critical thickness shall be determined as specified in 7.6.6.

### 7.3.3 Specimen size and orientation

When the use of full-size (10 mm × 10 mm) transverse test specimens is not possible, the largest possible sub-size transverse test specimen listed in Table C.9 or Table E.9 shall be used. When it is not possible (or allowed in accordance with 7.3.6) to test using any of these transverse test specimens, the largest possible longitudinal test specimen listed in Table C.9 or Table E.9 shall be used.

When testing EW pipe using a transverse test specimen, the weld line shall be positioned at the notch in the Charpy test specimen.

When the outside diameter or wall thickness precludes the machining of longitudinal impact test specimens ½-size or larger, the pipe need not be tested; however, the manufacturer shall use a chemical composition and processing that is documented and demonstrated to result in impact-energy absorption which meets or exceeds the minimum specified requirement.

### 7.3.4 Hierarchy of test specimens

The hierarchy of test specimen orientation and size is specified in Table C.10 or Table E.10.

### 7.3.5 Alternative size impact test specimens

At the manufacturer's option, impact test specimens of an alternative size, listed in Table C.9 or Table E.9, may be used in lieu of the minimum size specified in Tables C.11 through C.16, C.21, C.22 and Tables E.11 through E.16, E.21 and E.22. However, the alternative test specimen selected shall be higher on the hierarchy table (Table C.10 or Table E.10) than the specified size, and the absorbed energy requirement shall be adjusted consistent with the orientation and size of the impact specimen.

### 7.3.6 Sub-size test specimens

The minimum CVN absorbed energy requirement for sub-size test specimens shall be that specified for a full-size test specimen multiplied by the reduction factor in Table C.9 or Table E.9; however, in no event shall a sub-size test specimen be used if the reduced absorbed-energy requirement is less than 11 J (8 ft-lb).

### 7.3.7 Test temperature

The test temperature shall be 0 °C (32 °F) for all groups except Group 1, Grades J55 and K55. Grades J55 and K55 shall be tested at 21 °C (70 °F). An alternative lower test temperature may be specified on the purchase agreement or selected by the manufacturer for any grade. The tolerance on the test temperature shall be  $\pm 3$  °C ( $\pm 5$  °F).

A reduction in test temperature may be required for Grades J55 and K55 when sub-size specimens are used. The amount of test-temperature reduction depends on the critical thickness of the connection and the size of the impact test specimen. The test-temperature reduction specified in Table C.11 or Table E.11 shall be used when applicable.

### 7.3.8 Statistical impact testing

By agreement between purchaser and manufacturer, the supplementary requirements for statistical impact testing in A.7 (SR 12) shall apply.

### 7.3.9 Reference information

ISO 10400 or API Bul 5C3 includes reference information on fracture mechanics and equations and tables used in preparing impact requirements.

## 7.4 Charpy V-notch test — Absorbed energy requirements for coupling stock, coupling blanks and couplings

### 7.4.1 General

Coupling stock suitable for more than one type of connection may be qualified by a test to demonstrate conformance to the most stringent requirements. The test specimen orientation and size shall be the highest possible listed on the hierarchy in Table C.10 or Table E.10 and the absorbed energy requirement shall equal or exceed the applicable requirements.

### 7.4.2 Grade H40

There is no mandatory CVN impact energy requirement.

NOTE See A.10 (SR16) for optional CVN requirements.

### 7.4.3 Grades J55 and K55 for API threads

The minimum full-size transverse absorbed energy requirement  $C_V$  is 20 J (15 ft-lb). The minimum full-size longitudinal absorbed energy requirement  $C_V$  is 27 J (20 ft-lb). The impact specimen orientation, minimum size, minimum absorbed energy requirement (that is, adjusted for the size of specimen indicated), and test temperature reduction (as applicable) for couplings are provided in Table C.11 or Table E.11.

### 7.4.4 Grade M65 for API threads

There are no Grade M65 couplings. Grade L80 Type 1 couplings shall be used on Grade M65 pipe.

### 7.4.5 Grades N80 Type 1 and N80Q, Groups 2 (except M65), 3 and 4 for API threads

The impact specimen orientation, minimum size and minimum absorbed energy requirement  $C_V$  (i.e. adjusted for the specimen size indicated) for couplings are provided in Tables C.12 to C.16 or Tables E.12 to E.16.

The minimum absorbed energy requirements,  $C_V$ , for full-size test specimens are calculated based on the equations below, where:

$YS_{max}$  is the specified maximum yield strength for the grade evaluated, in megapascals (thousand pounds per square inch);

$t$  is the critical wall thickness, in millimetres (inches), based on the specified dimensions for couplings.

Unit system	Transverse requirement $C_V$	Longitudinal requirement $C_V$
SI units, joules	$YS_{max} \cdot (0,001\ 18 \cdot t + 0,012\ 59)$ or 20 J, whichever is greater (Table C.17)	$YS_{max} \cdot (0,002\ 36 \cdot t + 0,025\ 18)$ or 41 J, whichever is greater (Table C.18)
USC units, foot-pounds	$YS_{max} \cdot (0.152 \cdot t + 0.064)$ or 15 ft-lb whichever is greater (Table E.17)	$YS_{max} \cdot (0.304 \cdot t + 0.128)$ or 30 ft-lb, whichever is greater (Table E.18)

### 7.4.6 Special end-finish

The critical thickness shall be as specified in 7.6.6. The absorbed energy requirements in 7.4.1 to 7.4.5 shall apply.

## 7.5 Charpy V-notch test — Absorbed energy requirements for pipe

### 7.5.1 Grades H40, J55, K55 and N80 Type 1

There is no mandatory CVN impact requirement.

Additional requirements for PSL-2 and PSL-3 products are specified in Annex H.

NOTE See A.10 (SR16) for optional CVN impact energy requirements.

### 7.5.2 Grade M65

The minimum full-size transverse absorbed energy requirement shall be 20 J (15 ft-lb). The minimum full-size longitudinal absorbed energy requirement shall be 41 J (30 ft-lb).

**7.5.3 Grades N80Q, L80, C90, C95, T95 and P110**

The minimum absorbed energy requirement,  $C_V$ , for full-size test specimens is provided in Tables C.19 and C.20 or Tables E.19 and E.20.

Additional requirements for PSL-2 and PSL-3 products are specified in Annex H.

The requirements are calculated based on the equations given below, where:

$Y_{S_{min}}$  is the specified minimum yield strength, in megapascals (thousand pounds per square inch);

$t$  is the specified wall thickness, in millimetres (inches).

Unit system and grade	Transverse requirement $C_V$	Longitudinal requirement $C_V$
SI units, joules Grades N80Q, L80, C90, C95, T95	$Y_{S_{min}} \cdot (0,001\ 18 \cdot t + 0,012\ 59)$ or 14 J, whichever is greater (Table C.19)	$Y_{S_{min}} \cdot (0,002\ 36 \cdot t + 0,025\ 18)$ or 27 J, whichever is greater (Table C.20)
SI units, joules Grade P110	$Y_{S_{min}} \cdot (0,001\ 18 \cdot t + 0,012\ 59)$ or 20 J, whichever is greater (Table C.19)	$Y_{S_{min}} \cdot (0,002\ 36 \cdot t + 0,025\ 18)$ or 41 J, whichever is greater (Table C.20)
USC units, foot pounds Grades N80Q, L80, C90, C95, T95	$Y_{S_{min}} \cdot (0.152 \cdot t + 0.064)$ or 10 ft-lb, whichever is greater (Table E.19)	$Y_{S_{min}} \cdot (0.304 \cdot t + 0.128)$ or 20 ft-lb, whichever is greater (Table E.20)
USC units, foot pounds Grade P110	$Y_{S_{min}} \cdot (0.152 \cdot t + 0.064)$ or 15 ft-lb, whichever is greater (Table E.19)	$Y_{S_{min}} \cdot (0.304 \cdot t + 0.128)$ or 30 ft-lb, whichever is greater (Table E.20)

**7.5.4 Grade Q125**

The minimum absorbed energy requirement for full-size test specimens is provided in Tables C.19 and C.20 or Tables E.19 and E.20.

Additional requirements for PSL-2 and PSL-3 products are specified in Annex H.

The requirements are calculated based on the equations given below where:

$Y_{S_{max}}$  is the specified maximum yield strength, in megapascals (1 034 MPa) [thousand pounds per square inch (150 ksi)];

$t$  is the specified wall thickness, in millimetres (inches).

Unit system	Transverse requirement $C_V$	Longitudinal requirement $C_V$
SI units, joules Grade Q125	$Y_{S_{max}} \cdot (0,001\ 18 \cdot t + 0,012\ 59)$ or 20 J whichever is greater (Table C.19)	$Y_{S_{max}} \cdot (0,002\ 36 \cdot t + 0,025\ 18)$ or 41 J whichever is greater (Table C.20)
USC units, foot pounds Grade Q125	$Y_{S_{max}} \cdot (0.152 \cdot t + 0.064)$ or 15 ft-lb whichever is greater (Table E.19)	$Y_{S_{max}} \cdot (0.304 \cdot t + 0.128)$ or 30 ft-lb, whichever is greater (Table E.20)

### 7.5.5 Test specimen

Table C.21 or Table E.21 for transverse specimens and Table C.22 or Table E.22 for longitudinal specimens provide the calculated wall thickness required to machine full-size,  $\frac{3}{4}$ -size, and  $\frac{1}{2}$ -size impact test specimens. The impact test specimen size that shall be selected from these tables is the largest impact test specimen having a calculated wall thickness that is less than the specified wall thickness for the pipe tested.

### 7.5.6 Testing conditions

For Grades M65 and Q125 pipe, impact testing in accordance with 10.7 is mandatory. For all other grades except Grades H40, J55, K55 and N80 Type 1 (which have no mandatory impact requirements for pipe), compliance with the requirements of 7.5.3 may be qualified by a documented procedure in lieu of testing, at the manufacturer's option, unless A.10 (SR16) is specified on the purchase agreement, in which case testing is mandatory as specified in 10.7. Pipe qualified by a documented procedure that fails to show conformance to the specified impact energy requirements after shipment shall be rejected.

## 7.6 Charpy V-notch test — Absorbed energy requirements for casing and tubing accessories

### 7.6.1 Accessories — General

If the accessory has an API internally threaded connection, the minimum impact energy requirement for the accessory shall not be less than the requirement for that particular connection.

### 7.6.2 Accessories with internal API threads except integral joint tubing connections and extreme line casing connections

The requirements in 7.4.1 to 7.4.5 apply.

### 7.6.3 Accessories with internal special end-finish tapered interference-type threads

The requirements in 7.4.6 apply.

### 7.6.4 Accessories with external threads

The requirements in 7.5 apply.

### 7.6.5 Accessories with either integral joint tubing connections, extreme line casing connections or internal special end-finish connections that do not have thread interference

By agreement between the manufacturer and purchaser, the provisions of A.10 (SR16) shall apply.

### 7.6.6 Critical thickness for accessory material

If not specified on the purchase agreement, the critical thickness for determining the impact energy requirements shall be based on the thickness of the cross-section of the accessory that has the lowest  $t/D$  ratio, where  $D$  is the specified outside diameter and  $t$  is the calculated wall thickness at that section.

For an accessory with API internal threads, the critical thickness for these API threads is shown in Table C.8 or Table E.8, and  $D$  is the specified outside diameter of the connection as specified in 9.6 and 9.8.

For special end-finish connections, the critical thickness for externally threaded members is the specified pipe body thickness, while for internally threaded members it is the calculated thickness of the internally threaded member at the plane of the small end of the pin (when the connection is made up power-tight).

## 7.7 Maximum hardness

### 7.7.1 Group 2 — All product

The following hardness requirements are applicable if required in accordance with 10.6:

- a) Grades M65, L80 all types, C90 and T95

The hardness numbers and/or mean hardness numbers obtained shall comply with the requirements in Table C.6 or Table E.6.

- b) Grades C90 and T95 — Surface hardness

If the Brinell or Rockwell C-scale hardness number does not exceed 255 HBW or 25,4 HRC respectively, then the length or piece is acceptable. If any of the hardness numbers are over 255 HBW or 25,4 HRC two additional indentations may be made in the immediate area. If either of the second test hardness numbers exceeds 255 HBW or 25,4 HRC the length or piece shall be rejected.

- c) Grades C90 and T95 — Through-wall hardness

Products with mean Rockwell hardness number not exceeding 25,4 HRC are acceptable. If any hardness number from a single indentation exceeds 27,0 HRC, the length or piece shall be rejected. Products with mean hardness numbers between 25,4 HRC and 27,0 HRC shall be retested.

- d) Grades C90 and T95 — Alternative maximum hardness requirements

By agreement between the purchaser and manufacturer, the maximum mean hardness numbers may be altered from those stated above, based on sulfide stress corrosion cracking tests specified in 7.14.

### 7.7.2 Grade Q125 — All products

There are no upper or lower hardness limits for these products.

## 7.8 Hardness variation — Grades C90, T95 and Q125

Material shall conform to the hardness variation requirements of Table C.6 or Table E.6. Hardness variation is defined as the difference between any two mean hardness numbers within one quadrant. This criterion shall not apply between specimens.

## 7.9 Process control — Grades C90, T95 and Q125

All individually heat-treated coupling blanks, pup joints or accessories shall be surface hardness-tested to verify process control. For Grades C90 and T95, the surface hardness test results shall be used in the selection of the pieces for through-wall hardness testing. The process-control hardness test results need not be provided by the manufacturer or processor unless specified on the purchase agreement.

## 7.10 Hardenability — Minimum percentage martensite for quenched and tempered products

### 7.10.1 Grades C90 and T95

For each size, mass, chemical composition and austenitize-and-quench combination, a through-wall hardness test shall be made on products after quenching and prior to tempering for each production run to characterize the hardening response. These tests shall be made on the body of products or, in the case of upset products or accessories, shall be made in the upset or design area of greatest wall thickness. Mean hardness numbers shall equal or exceed the hardness corresponding to a minimum of 90 % martensite, as determined by the following equation:

$$\text{HRC}_{\min} = 58 \times (\% \text{ carbon}) + 27$$

NOTE The above equation was derived from data in reference [2]. Based on these data, the above equation is valid from 0,15 % carbon to 0,50 % carbon.

Additional requirements for PSL-3 products are specified in Annex H.

### 7.10.2 All grades except Grades C90 and T95

For each size, mass, chemical composition and austenitize-and-quench combination, a through-wall hardness test shall be made after quenching and prior to tempering as part of a documented procedure to confirm sufficient hardening. These tests shall be made on the body of products or, in the case of upset products or accessories, shall be made in the upset or design area of greatest wall thickness. Mean hardness numbers shall equal or exceed the hardness corresponding to a minimum of 50 % martensite, as determined by the following equation:

$$\text{HRC}_{\min} = 52 \times (\% \text{ carbon}) + 21$$

Additional requirements for PSL-2 and PSL-3 products are specified in Annex H.

### 7.11 Grain size — Grades C90 and T95

Prior austenitic grain size shall be ASTM 5 or finer (determined in accordance with ISO 643 or ASTM E112).

### 7.12 Surface condition — Grades L80 9Cr and L80 13Cr

The internal surface of the pipe shall be free from scale after the final heat treatment.

Additional requirements for PSL-2 and PSL-3 products are specified in Annex H.

### 7.13 Flattening — Electric-welded pipe

All products that are produced by the electric-weld process of manufacture shall comply with the flattening requirements shown in Table C.23 or Table E.23.

### 7.14 Sulfide stress cracking test — Grades C90 and T95

#### 7.14.1 Test and re-test requirements

For each heat, manufacturers shall demonstrate that the product meets or exceeds the minimum SSC threshold using one of the ANSI-NACE TM0177-96 test methods given below. If the purchaser requires an SSC threshold higher than the minimum, or requires a specific test method from the list below, agreement shall be reached between purchaser and manufacturer. For Methods A and D, sub-size or alternative specimens shall only be used following agreement with the purchaser. When Method D sub-size or alternative specimens are required, acceptance criteria shall be agreed between the purchaser and manufacturer.

Additional requirements for PSL-3 products are specified in Annex H.

The details of a manufacturer's qualification, frequency of sulfide stress cracking testing, re-test procedures and testing practices should be addressed by the purchaser and the manufacturer prior to placing or accepting a purchase order.





- The test solution shall have 0,5 % mass fraction glacial acetic acid dissolved in distilled or de-ionized water.
- The test solution shall be saturated with H<sub>2</sub>S as described in ANSI-NACE TM0177-96.

## 8 Dimensions, masses, tolerances, pipe ends and defects

### 8.1 Labels and sizes

In the dimensional tables in this International Standard, pipe is designated by labels and by size (outside diameter). The outside diameter size of external-upset pipe is the outside diameter of the body of the pipe, not the upset portion.

### 8.2 Dimensions and masses

Pipe shall be furnished in the sizes, wall thicknesses and masses (as shown in Tables C.24 to C.29 inclusive or Tables E.24 to E.29 inclusive) as specified on the purchase agreement. Other plain-end pipe sizes and wall thicknesses may be furnished by agreement between purchaser and manufacturer. Coupling stock shall be furnished in dimensions as specified on the purchase agreement. Coupling stock outside diameter and wall thickness combinations shall exclude those in Tables C.1, C.2, C.3 or Tables E.1, E.2, E.3. All dimensions shown without tolerances are related to the basis for design and are not subject to measurement to determine acceptance or rejection of product.

Casing sizes larger than Label 1: 4-1/2 but smaller than Label 1: 10-3/4 may be specified by the purchaser to be used in tubing service, see Tables C.1, C.24, C.30 and C.31 or Tables E.1, E.24, E.30 and E.31.

The accuracy of all measuring equipment used for acceptance or rejection, except ring-and-plug thread gauges and weighing devices, shall be verified at least every operating shift.

Verifying the accuracy of measuring devices such as snap gauges and drift mandrels shall consist of inspection for wear and conformance to specified dimensions. Verifying the accuracy of rules, length-measuring tapes and other non-adjustable measuring devices shall consist of a visual check for the legibility of markings and general wear of fixed reference points. The adjustable and non-adjustable designations of measuring devices utilized by the manufacturer shall be documented.

The verification procedure for working ring-and-plug thread gauges shall be documented. The accuracy of all weighing devices shall be verified at periods not to exceed those required by the manufacturer's documented procedure in accordance with National Institute of Standards and Technology (NIST) standards or equivalent regulations in the country of manufacture of products made to this International Standard.

If measuring equipment whose calibration or verification is required under the provisions of this International Standard is subjected to unusual or severe conditions sufficient to make its accuracy questionable, re-calibration or re-verification shall be performed before further use of the equipment.

### 8.3 Diameter

#### 8.3.1 Measurement and design

##### a) Using SI units

For measurement of diameter, an accuracy of one decimal place shall be used for sizes larger than Label 1: 6-5/8. In this International Standard two decimal places are used for design purposes to ensure interchangeability.

##### b) Using USC units

The diameter shall be rounded to three decimal places.

### 8.3.2 Requirements

The outside diameter shall be within the tolerances specified in 8.11.1. For threaded pipe, the outside diameter at the threaded ends shall be such that the thread length,  $L_4$ , and the full-crest thread length,  $L_C$ , are within the tolerances and dimensions specified in API Spec 5B. For pipe furnished non-upset and plain-end and which is specified on the purchase agreement for the manufacture of pup joints, the non-upset plain-end tolerances shall apply to the full length.

### 8.4 Wall thickness

For pipe, the wall thickness at any place shall not be less than the tabulated thickness,  $t$ , minus the permissible under-tolerance specified in 8.11.2.

For coupling stock, the wall thickness tolerance shall be as specified on the purchase agreement.

### 8.5 Mass

The masses determined as described in 10.13.7 shall conform to the calculated masses as specified herein (or adjusted calculated masses) for the end-finish specified on the purchase agreement, within the tolerances stipulated in 8.11.3. Calculated masses shall be determined in accordance with the following formula:

$$m_L = (m_{pe} \cdot L) + e_m$$

where

$m_L$  is the calculated mass of a piece of pipe of length  $L$ , in kilograms (pounds);

$m_{pe}$  is the plain-end mass, in kilograms per metre (pounds per foot);

$L$  is the length of pipe, including end-finish, in metres (feet), as defined in 8.6;

$e_m$  is the mass gain or loss due to end-finishing, in kilograms (pounds).  
For plain-end non-upset pipe,  $e_m = 0$ .

NOTE The densities of martensitic chromium steels (L80 Types 9Cr and 13Cr) are less than those of carbon steels. The masses shown are therefore not accurate for martensitic chromium steels. A mass correction factor of 0,989 may be used.

### 8.6 Length

Casing, tubing, plain-end liners, and pup joints shall be furnished in lengths conforming to Table C.30 or Table E.30. The length of coupling stock and accessories, except couplings, shall be as specified on the purchase agreement. The length of each finished pipe shall be determined for conformance to length requirements. Length determination shall be in metres and hundredths of a metre (feet and tenths of a foot).

The accuracy of length-measuring devices for lengths of pipe less than 30 m (100 ft) shall be  $\pm 0,03$  m ( $\pm 0.1$  ft).

### 8.7 Casing jointers

If so specified on the purchase agreement, for round thread casing only, jointers (two pieces coupled to make a standard length) may be furnished to a maximum of 5 % of the order; but no length used in making a jointer shall be less than 1,52 m (5.0 ft).

**8.8 Height and trim of electric-weld flash**

**8.8.1 Trimming electric-weld flash**

The outside flash of electric-welded pipe shall be trimmed to an essentially flush condition.

It shall be the aim of the manufacturer to provide an inside surface at the weld of electric-weld pipe that is:

- a) reasonably close to flush after trimming; and
- b) contains no jagged edges from the original weld flash.

It may be desirable for the manufacturer to provide an inside surface at the trimmed weld with a slight groove in order to meet this aim. The inside flash of electric-welded pipe shall be trimmed as given in 8.8.2 and 8.8.3.

**8.8.2 Groups 1 and 2**

The height of the inside weld flash shall not exceed 1,14 mm (0.045 in) for casing or casing pup joints or 0,38 mm (0.015 in) for tubing or tubing pup joints, measured from the inside surface adjacent to the flash.

The depth of groove resulting from removal of the inside flash shall not be greater than the amount listed below for the various wall thicknesses. Depth of groove is the difference between the wall thickness measured approximately 25 mm (1 in) from the weld line and the remaining wall under the groove.

Wall thickness	Maximum depth of trim
3,84 mm to 7,64 mm (0.151 in to 0.301 in)	0,38 mm (0.015 in)
$\geq 7,64$ mm ( $\geq 0.301$ in)	$0,05 \cdot t$

**8.8.3 Groups 3 and 4**

No inside flash height shall be permitted. The groove on the inside weld surface shall not exceed a depth of 0,38 mm (0.015 in) and shall not contain sharp corners that would interfere with ultrasonic inspection.

**8.8.4 Disposition**

Pipe with weld flash exceeding the limits specified in 8.8.2 or 8.8.3, as applicable, shall be either rejected or repaired by grinding.

**8.9 Straightness**

**8.9.1 Pipe**

Deviation from straight, or chord height, shall not exceed either of the following:

- a) 0,2 % of the total length of the pipe measured from one end of the pipe to the other end, for pipes Label 1: 4-1/2 and larger;
- b) 3,18 mm (1/8 in) maximum drop in the 1,5 m (5.0 ft) length at each end. See Figures D.14 and D.15.

**8.9.2 Coupling stock**

Straightness requirements for coupling stock shall be as agreed between the purchaser and manufacturer.

## 8.10 Drift requirements

Each length of casing and tubing either finished or unfinished shall be drift-tested throughout its entire length. Casing and tubing threaded by an entity other than the pipe manufacturer shall also be drift-tested for a distance of 0,6 m (24 in) from the coupled end on casing and 1,1 m (42 in) from the coupled end on tubing. Drift dimensions (length and diameter) shall comply with Table C.31 or Table E.31.

Casing sizes larger than Label 1: 4-1/2 but smaller than Label 1: 10-3/4 specified by the purchaser to be used in tubing service shall be drift-tested with drift mandrels as indicated hereafter, and marked as specified in Clause 11.

NOTE See ISO 10400 or API Bull 5C3 for the joint strength of casing used in tubing service.

Label 1	Mandrel length	Mandrel diameter
> 4-1/2 to ≤ 8-5/8	1 067 mm (42.0 in)	$d - 3,18 \text{ mm } (d - 1/8 \text{ in})$
> 8-5/8 to < 10-3/4	1 067 mm (42.0 in)	$d - 3,97 \text{ mm } (d - 5/32 \text{ in})$

When specified by the purchaser as "alternative drift casing", casing in the sizes and masses in Table C.32 or Table E.32 shall be tested with the alternative drift mandrels as shown. Pipe which is drifted with the alternative drift mandrels shall be marked as described in Clause 11.

## 8.11 Tolerances on dimensions and masses

### 8.11.1 Outside diameter, $D$

The following tolerances apply to the outside diameter,  $D$ , of pipe:

Label 1	Tolerance on outside diameter, $D$
< 4-1/2	± 0,79 mm (± 0.031 in)
≥ 4-1/2	$\begin{matrix} +1 \\ -0,5 \end{matrix} \% D$

For upset pipe, the following tolerances apply to the outside diameter of the pipe body immediately behind the upset for a distance of approximately 127 mm (5.0 in) for sizes Label 1: 5-1/2 and smaller, and a distance approximately equal to the outside diameter for sizes larger than Label 1: 5-1/2. Measurements shall be made with callipers or snap gauges.

Label 1	Tolerances behind $m_{eu}$ or $L_0$
≥ 3-1/2	$\begin{matrix} +2,38 \\ -0,79 \end{matrix} \text{ mm } \left( \begin{matrix} +3/32 \\ -1/32 \end{matrix} \text{ in} \right)$
> 3-1/2 to ≤ 5	+ 2,78 mm to - 0,75 % $D$ (+ 7/64 in to - 0.75 % $D$ )
> 5 to ≤ 8-5/8	+ 3,18 mm to - 0,75 % $D$ (+ 1/8 in to - 0.75 % $D$ )
> 8-5/8	+ 3,97 mm to - 0,75 % $D$ (+ 5/32 in to - 0.75 % $D$ )

For Label 1: 2-3/8 and larger external-upset tubing, the following tolerances shall apply to the outside diameter at distance  $L_a$  (see Figure D.5) from the end of the pipe.

The measurements shall be made with snap gauges or callipers. Changes in diameter between  $L_a$  and  $L_b$  shall be smooth and gradual. Pipe body OD tolerances do not apply for a distance of  $L_b$  from the end of the pipe.

Label 1	Tolerances
$\geq 2\text{-}3/8$ to $\leq 3\text{-}1/2$	+ 2,38 mm (+ 3/32 in) - 0,79 mm (- 1/32 in)
$> 3\text{-}1/2$ to $\leq 4$	+ 2,78 mm (+ 7/64 in) - 0,79 mm (- 1/32 in)
$> 4$	+ 2,78 mm to - 0,75 % $D$ (+ 7/64 in to - 0.75 % $D$ )

For coupling stock, outside diameter tolerances shall be as specified on the purchase agreement.

### 8.11.2 Wall thickness, $t$

Tolerance for pipe - 12,5 %

For coupling stock, wall thickness tolerances shall be as specified on the purchase agreement.

### 8.11.3 Mass

Amount	Tolerance
Single lengths	+ 6,5 % - 3,5 %
Carload 18 144 kg (40 000 lb) or more	- 1,75 %
Carload less than 18 144 kg (40 000 lb)	- 3,5 %
Order items 18 144 kg (40 000 lb) or more	- 1,75 %
Order items less than 18 144 kg (40 000 lb)	- 3,5 %

### 8.11.4 Inside diameter, $d$

Inside diameter,  $d$ , is governed by the outside diameter and mass tolerances.

### 8.11.5 Upset dimensions

Tolerances on upset dimensions are given in Tables C.26, C.27 and C.28 or Tables E.26, E.27 and E.28.

### 8.11.6 Extended length upsets

External upset tubing may be ordered with extended length upsets ( $L_{el}$ ) as agreed between purchaser and manufacturer. A minimum of 95 % of the number of joints (both ends) shall meet the  $L_{el}$  with the remaining balance meeting  $L_{eu}$  requirements, unless otherwise agreed between purchaser and manufacturer.

## 8.12 Pipe ends

### 8.12.1 Unfinished pipe

Unfinished pipe is pipe furnished unthreaded, either upset or non-upset, but in compliance with all requirements of this International Standard for a particular grade, and shall be marked as specified in 11.5.2.

### 8.12.2 Casing with API threads

Unless otherwise stated on the purchase agreement, casing shall be furnished threaded and coupled, 8-round long or short thread as applicable. If specified on the purchase agreement, casing shall be furnished with one of the following end-finishes:

— 8-round thread without coupling;

- buttress thread with coupling;
- buttress thread without coupling;
- extreme-line thread;
- enhanced leak resistance LTC connections.

Additionally, seal ring configuration in accordance with A.8 (SR13) may be ordered.

Some items of Grades H40, J55, K55 or M65 casing are available in either short or long thread forms (see Table C.1 or Table E.1). If long thread is desired on these items, the purchaser shall so specify on the purchase agreement. Otherwise short-thread casing in accordance with Table C.24 or Table E.24 shall be furnished.

Liners shall be furnished with square-cut plain ends, with all burrs removed from both inside and outside edges.

### 8.12.3 Tubing with API threads

Unless otherwise stated on the purchase agreement, tubing shall be threaded and coupled. If specified on the purchase agreement, tubing shall be furnished with any of the following end-finishes:

- threaded ends without coupling;
- integral joint.

Additionally, seal ring configuration according to A.8 (SR13) may be ordered.

### 8.12.4 Rounded nose

In lieu of the conventional corner breaks on the threaded ends of tubing, the “round” or “bullet-nose” end may be supplied at the manufacturer’s option or may be specified by the purchaser. The modified end shall be rounded to provide for coatable service, and the radius transition shall be smooth with no sharp corners, burrs, or slivers on the ID or OD chamfer surfaces. See Figure D.6 for an illustration and dimensions. It is recognized that the dimensions in Figure D.6 are recommended values but are not subject to measurement to determine acceptance or rejection of the product.

### 8.12.5 Pup joints and accessories

Pup joints and accessories shall be furnished with threaded ends without couplings unless otherwise specified.

### 8.12.6 Threading

Pipe threads, gauging practice and thread inspection shall conform to the requirements of API Spec 5B. Pipe ends shall not be rounded out by hammering to secure conformance with threading requirements.

### 8.12.7 Workmanship of ends

The inside and outside edges of the ends of all pipe shall be free of burrs. The threads of martensitic chromium alloys have shown a tendency toward adhesive wear, or galling during make-up and breakout. Their galling resistance may be improved by surface preparations which are beyond the scope of this International Standard.

Additional requirements for PSL-2 and PSL-3 products are specified in Annex H.

### 8.12.8 Special end-finish

Pipe with end-finish not specified in this International Standard may be furnished if so specified in the purchase agreement. This pipe shall have the body of the pipe manufactured in accordance with the requirements of this International Standard. When threaded by the pipe mill or processor, the pipe shall be marked as specified in 11.5.2.

Completed couplings and completed accessories with end-finish not specified in this International Standard may be furnished if so specified in the purchase agreement. These items shall be manufactured in accordance with the requirements of this International Standard, except for end-finish and dimensions, and shall be marked as specified in 11.5.2.

## 8.13 Defects

### 8.13.1 Pipe and accessories

All pipe and accessories shall be free from defects as listed hereafter:

- a) any quench crack;
- b) any surface-breaking imperfection which is proven to reduce the net effective wall thickness below 87,5 % of the specified wall thickness;
- c) when NDE (except visual) is specified by this International Standard [see 10.15, A.2 (SR1) and A.3 (SR2)] or specified on the purchase agreement, any non-surface-breaking imperfection detected that, when outlined on the outside surface, has an area greater than 260 mm<sup>2</sup> (0.40 in<sup>2</sup>);
- d) any non-surface-breaking weld seam imperfection within 1,6 mm (1/16 in) of either side of the weld line that is proven to reduce the net effective wall thickness below 87,5 % of the specified wall thickness;
- e) any linear imperfection on the outside or inside surface, of any orientation, with a depth greater than tabulated in Table C.33 or Table E.33;
- f) any surface-breaking pipe upset imperfection, of any orientation, with a depth greater than tabulated in Table C.34 or Table E.34;
- g) on the internal upset configuration on all upset products, any sharp corner or drastic change of section that would cause a 90° hook-type tool to hang up (see Figure D.26).

### 8.13.2 Coupling stock

All coupling stock shall be free from any quench crack. All coupling stock shall be free from, or have clearly marked, any outside surface-breaking imperfection with a depth greater than 5 % of the manufactured wall thickness or which is proven to reduce the outside diameter or wall thickness below specified tolerances. Also, the requirement of 8.13.1 c) shall apply.

### 8.13.3 Process control plan

The manufacturer, based on knowledge of the production process and the requirements of Clause 10, shall apply a process control plan that will ensure that the above requirements are fulfilled.

## 8.14 Coupling make-up and thread protection

### 8.14.1 Groups 1, 2 and 3

All casing couplings and regular tubing couplings shall be screwed onto the pipe power-tight, except that they shall be screwed on handling-tight (see Note 1 below) or shipped separately if so specified on the purchase



agreement. Special-clearance tubing couplings shall be screwed onto the pipe handling-tight, except that they shall be shipped separately if so specified on the purchase agreement.

A thread compound shall be applied to cover the full surface on the engaged thread of either the coupling or pipe before making up the joint. Application on both coupling and pipe may be agreed between purchaser and manufacturer. Unless otherwise specified by the purchaser, the thread compound shall conform to ISO 13678. When pipe is furnished threaded and coupled, the field end and the coupling shall be provided with thread protectors. When pipe is furnished threaded, but without couplings attached, each end shall be provided with a thread protector. Thread protectors shall conform to the requirements of 12.2. All exposed threads shall be coated with thread compound. A storage compound of distinct colour may be substituted for this thread compound on all exposed threads. The compound shall be applied to a surface that is clean and reasonably free of moisture and cutting fluids.

NOTE 1 For the purposes of this provision, API RP 5A3 is equivalent to ISO 13678.

NOTE 2 The purpose of making up couplings handling-tight is to facilitate removal of the couplings for cleaning and inspecting threads and applying fresh thread compound before using the pipe. This procedure has been found to result in less chance for thread leakage, because mill-applied couplings made up power-tight, although leak-proof at the time of make-up, may not always remain so after transportation, handling and use.

NOTE 3 Martensitic chromium steels are sensitive to galling. Special precautions may be necessary for thread surface treatment and/or lubrication to minimize galling during hydrostatic testing (plug application and removal).

#### 8.14.2 Group 4

The requirements for Group 4 are the same as that shown in 8.14.1, except that couplings with API threads shall be shipped separately unless power-tight make-up is specified on the purchase agreement.

## 9 Couplings

### 9.1 General requirements

Couplings shall be seamless, be of the same grade and type as the pipe, and be given the same heat treatment as the pipe except as provided in 9.2. This International Standard does not require that coupling blanks be cut from tubulars which have been ordered as coupling stock in accordance with this International Standard.

When couplings are electroplated, the electroplating process should be controlled to minimize hydrogen absorption.

### 9.2 Alternative grades or heat treatments

9.2.1 When heat treatment is not stipulated on the purchase agreement, Grade H40 pipe shall be furnished with Grade H40, J55 or K55 couplings which are either as-rolled, normalized, normalized and tempered, or quenched and tempered.

9.2.2 When heat treatment is not stipulated on the purchase agreement, Grade J55 pipe shall be furnished with Grade J55 or K55 couplings which are either as-rolled, normalized, normalized and tempered, or quenched and tempered.

9.2.3 When heat treatment is not stipulated on the purchase agreement, Grade K55 pipe shall be furnished with Grade K55 couplings which are either as-rolled, normalized, normalized and tempered, or quenched and tempered.

9.2.4 Grade J55 EUE tubing shall be furnished with Grade L80 Type 1 special clearance couplings when specified on the purchase agreement.

**9.2.5** Grades J55 and K55 buttress casing shall be furnished with Grade L80 Type 1 couplings when specified on the purchase agreement.

**9.2.6** Grade M65 products shall be furnished with Grade L80 Type 1 couplings.

**9.2.7** Normalized Grade N80 Type 1 pipe shall be furnished with either Grade N80 Type 1 or N80Q couplings.

**9.2.8** Normalized and tempered Grade N80 Type 1 pipe shall be furnished with either normalized and tempered Grade N80 Type 1 or N80Q couplings.

**9.2.9** Grades N80 Type 1 and N80Q EUE tubing shall be furnished with Grade P110 special clearance couplings when specified on the purchase agreement.

**9.2.10** Grades N80 Type 1 and N80Q buttress casing shall be furnished with Grade P110 couplings when specified on the purchase agreement.

**9.2.11** Grade P110 buttress casing shall be furnished with Grade Q125 couplings when specified on the purchase agreement.

### **9.3 Process of manufacture — Groups 1, 2 and 3**

Couplings made from seamless pipe or hot forgings shall be heat-treated as required in 6.2.

### **9.4 Process of manufacture — Grade Q125**

Grade Q125 couplings shall be made from seamless coupling stock using the same requirements and quality control provisions as Grade Q125 casing manufactured to this International Standard (see Clauses 6 and 7). Couplings and coupling blanks shall be cut from coupling stock. See A.4 (SR9) for optional requirements for coupling blanks.

### **9.5 Mechanical properties**

Couplings shall conform to the mechanical requirements specified in Clauses 7 and 10, including the frequency of testing, re-test provision, etc. A record of these tests shall be open to inspection by the purchaser.

### **9.6 Dimensions and tolerances**

#### **9.6.1 Groups 1, 2 and 3**

Couplings shall conform to the dimensions and tolerances shown in Tables C.35 to C.38 or Tables E.35 to E.38. Unless otherwise specified on the purchase agreement, threaded and coupled casing and tubing shall be furnished with regular couplings.

#### **9.6.2 Group 4**

Couplings may be machined on the complete outside surface in addition to the inside surface. Dimensions shall be as specified on the purchase agreement unless couplings with standard API threads are ordered, in which case the dimensions shall be as shown in Tables C.35 and C.36 or Tables E.35 and E.36.

### **9.7 Regular couplings**

Regular couplings have diameters ( $W$ ) as shown in Tables C.35 to C.38 or Tables E.35 to E.38. The inside and outside edges of the bearing face shall be rounded or broken, but shall not materially reduce the width of the bearing face (dimension  $b$ ) so that enough thickness is left to safely support the mass of the pipe on the elevator. The ends of couplings shall be faced true at right angles to the axis.

## 9.8 Special-clearance couplings — Groups 1, 2 and 3

When specified in the purchase agreement, special-clearance (reduced outside diameter  $W_c$ ) couplings for buttress casing and external upset tubing shall be furnished. Unless otherwise specified, special-clearance external upset tubing couplings shall have a special bevel on both ends as specified in 9.12 and shown on Figure D.5.

When specified in the purchase agreement, special-clearance buttress thread casing couplings shall have a special bevel on both ends as shown on Figure D.3. The inside and outside edges of the bearing face shall be rounded or broken as shown on Figures D.3 and D.5.

The ends (or root face when bevelled) of couplings shall be faced true at right angles to the axis. Special-clearance couplings shall conform to the dimensions (except  $b$ ) and tolerances given in Tables C.36 and C.38 or Tables E.36 and E.38 and as shown on Figures D.3 and D.5.

See Clause 11 for marking and colour identification.

## 9.9 Combination couplings

Combination couplings with different types of thread of the same specified size shall be furnished when specified on the purchase agreement. The minimum length and minimum outside diameter of combination couplings shall be sufficient to accommodate the specified size and type of threads.

## 9.10 Reducing couplings — Groups 1, 2 and 3

Reducing couplings are used to connect two pipes of different diameter with the same or different types of thread on the two ends, and shall be furnished when specified on the purchase agreement. The minimum length and minimum diameter of reducing couplings shall be sufficient to accommodate the specified size and type of threads.

## 9.11 Seal-ring couplings

Seal-ring couplings conforming to the requirements of A.8 (SR13) shall be furnished when specified on the purchase agreement.

Additional requirements for PSL-2 and PSL-3 products are specified in Annex H.

## 9.12 Special-bevel tubing couplings — Groups 1, 2 and 3

When specified in the purchase agreement, special-bevel tubing couplings conforming to the requirements of Tables C.37 and C.38 or Tables E.37 and E.38 shall be furnished for non-upset and external-upset tubing. Unless otherwise specified, special bevel tubing couplings shall be bevelled on both ends as shown on Figures D.4 and D.5. The inside and outside edges of the bearing face shall be rounded or broken as shown on Figures D.4 and D.5. The root faces of the couplings shall be faced true at right angles to the axis.

## 9.13 Threading

### 9.13.1 General requirements

Coupling threads, gauging practice and thread inspection shall conform to the requirements of API Spec 5B. Couplings shall not be expanded to provide the required taper for threads for couplings with API threads.

Additional requirements for PSL-2 and PSL-3 products are specified in Annex H.

**NOTE** Couplings with API threads may not have a leak resistance as high as the internal yield pressure of the pipe body due to inadequate bearing pressure between the coupling and pin.

**9.13.2 Casing couplings — All groups**

Casing couplings shall be furnished with one of the following end-finishes, as specified on the purchase agreement:

- a) long or short 8-round thread;
- b) buttress — regular, special bevel and/or special clearance;
- c) seal-ring configuration A.8 (SR13);
- d) special end-finish.

**9.13.3 Tubing couplings — Groups 1, 2 and 3**

Tubing couplings shall be furnished with one of the following end-finishes as specified on the purchase agreement:

- a) 8- or 10-round thread for upset tubing — regular, special bevel or special clearance;
- b) 8- or 10-round thread for non-upset tubing — regular or special bevel;
- c) seal ring configuration A.8 (SR13);
- d) special end-finish.

**9.14 Surface inspection**

**9.14.1** All finished couplings shall be free from all imperfections that break the continuity of the thread.

**9.14.2** All couplings shall be inspected on the outside and inside surfaces after finish machining and before any inside or outside surface plating, using the wet fluorescent magnetic particle method in accordance with ISO 13665 or ASTM E709 with a circumferentially oriented magnetic field for the detection of longitudinal surface imperfections, or by other non-destructive method of equal sensitivity as demonstrated to the purchaser. Records shall be maintained in accordance with 10.15.4.

**9.14.3** By agreement between purchaser and manufacturer, NDE of Grades H40, J55 and K55 couplings may be waived. However, in this case, the couplings shall be inspected visually on the outside and inside surfaces after finish machining and before plating, and shall be free from all visible seams, cracks and porosity. See Table C.68 or Table E.68 for marking requirements.

**NOTE** Visible seams or cracks are those that can be seen without the aid of magnetic particle inspection, dye penetrant or other non-destructive methods of inspection.

**9.14.4** To ensure adequate plating or coating, the threaded surfaces of all couplings shall be visually inspected after plating or coating.

**9.14.5** All imperfections of any depth, revealed during inspection at the manufacturing facility, except as allowed in Table C.39 or Table E.39, shall be removed.

**9.14.6** Except as stated in 9.14.7, finished couplings re-inspected outside the manufacturer's facility in accordance with 9.14.2 or 9.14.3 shall be free from imperfections with the exception of those external imperfections given in Table C.39 or Table E.39.

**9.14.7** For Grades J55 and K55 material that is impact-tested at or below 0 °C (32 °F), that demonstrates a shear area greater than 80 % and that exceeds the minimum absorbed energy requirements, and for Grades N80 Type 1, N80Q and Groups 2, 3 and 4 material, couplings shall not be rejected for imperfections less than 5 % of the critical wall thickness detected on subsequent re-inspection outside the manufacturer's facility.

The critical thickness is defined in 7.3.2.

## 9.15 Measurement of imperfections

The depth of an imperfection shall be measured from the normal surface or contour of the coupling extended over the imperfection. The outside diameter of the finished coupling shall be measured across the finished surface or contour of the coupling (that is, the initial surface or grind contour resulting from the removal of an imperfection or defect). The outside diameter shall not be measured at the base of an acceptable pit.

## 9.16 Repair and removal of imperfections and defects

Repair welding is not permitted. Non-permissible imperfections defined in 9.14.5 shall be removed. Permissible imperfections, see Table C.39 or Table E.39, may be removed or reduced by machining or grinding on the outer surface, provided the outside diameter of the finished coupling is within the tolerances when measured at the point from where the defect was removed, or the coupling shall be rejected. The machining or grinding shall be approximately blended into the outer contour of the coupling.

After removal of the defect, the affected zone shall be re-inspected by the same inspection method at the same sensitivity used to perform the initial inspection or by a different inspection method of equal or greater sensitivity.

## 9.17 Thread surface treatment — Grade Q125

Thread surface treatment shall be as specified on the purchase agreement.

## 9.18 Couplings and coupling blank protection — Grades C90, T95 and Q125

All loose couplings and all coupling blanks that have been machined to their final outside diameter shall be boxed to prevent contact with one another during shipment. All other coupling blanks shall be boxed to prevent nicks and gouges that will not be removed by subsequent machining. Boxes shall be manufactured from suitable materials that prevent damage to the material surfaces during transportation and shall be designed to be easily handled by forklift.

# 10 Inspection and testing

## 10.1 Test equipment

The manufacturer shall determine the appropriate calibration frequency in order to be able to certify that all products conform to the requirements of this International Standard.

If test or measuring equipment, whose calibration or verification is required under the provisions of this International Standard, is subjected to unusual or severe conditions which make its accuracy questionable, re-calibration or reverification shall be performed before further use of the equipment.

## 10.2 Lot definition for testing of mechanical properties

### 10.2.1 Groups 1, 2 (Grades M65, L80 Type 1, and C95 only) and 3 — Coupling stock and pipe except pup joints heat-treated after cutting to blank or individual length

A lot is defined as all those lengths with the same specified dimensions and grade which are either as-rolled or heat-treated as part of a continuous operation (or batch), and are from a single heat of steel, or from different heats that are grouped according to a documented procedure which will ensure that the appropriate requirements of this International Standard are met.

### 10.2.2 Grades L80 9Cr, L80 13Cr, C90, T95 and Q125 — Coupling stock and pipe except pup joints heat-treated after cutting to blank or individual length

A lot is defined as all those lengths with the same specified dimensions and grade, from the same heat of steel which are heat-treated as part of a continuous operation (or batch).

### 10.2.3 Coupling blanks, pup joints or accessories heat-treated after cutting to blank or individual length

A lot is defined as that group of pieces with the same specified dimensions and grade, from the same heat of steel which has been

- a) batch heat-treated concurrently in the same heat-treating facility or
- b) heat-treated in sequential loads to the same cycle without interruption in the same heat-treating facility equipped with a recording controller to provide documentation of heat-treating control through the run or
- c) individually heat-treated in a continuous production run of 8 h or less in the same heat-treating facility.

In addition, for Grades C90, T95 and Q125, a lot shall not exceed 30 couplings, pup joints or accessories for Label 1: 9-5/8 and larger casing, or 50 couplings, pup joints or accessories for smaller sizes of individually heat-treated pieces.

## 10.3 Testing of chemical composition

### 10.3.1 Couplings, pup joints and accessories

For couplings, pup joints and accessories the analyses requested shall be furnished by the steel manufacturer or processor and shall be taken from material in tubular or bar form.

### 10.3.2 Heat analyses

For Groups 1, 2 and 3, when requested by the purchaser, the manufacturer shall furnish a report giving the heat analysis of each heat of steel used in the manufacture of pipe, coupling stock and couplings furnished on the purchase agreement. In addition the purchaser, upon request, shall be furnished the results of quantitative analyses for other elements used by the manufacturer to control mechanical properties.

For Grade Q125, the manufacturer shall furnish a report giving the heat analysis of each heat of steel used in the manufacture of pipe, coupling stock and couplings furnished on the purchase agreement. The report shall include quantitative analyses for other elements used by the manufacturer to control mechanical properties.

### 10.3.3 Product analyses

Two tubular products from each heat used shall be analysed for product analyses. Product analyses shall be made by the manufacturer on the finished tubular product. For electric-welded products, the chemical analysis may be determined on samples of skelp.

Product analyses shall include the results of quantitative determinations of all elements listed in Table C.5 or Table E.5 plus any other elements used by the manufacturer to control mechanical properties.

For Groups 1, 2 and 3, the product analyses shall be available to the purchaser on request.

For Group 4, the product analyses shall be provided to the purchaser.

### 10.3.4 Test method

Chemical composition shall be determined by any of the procedures commonly used for determining chemical composition, such as emission spectroscopy, X-ray emission, atomic absorption, combustion techniques or wet analytical procedures. The calibration methods used shall be traceable to established standards. In case of conflict, chemical analyses shall be made in accordance with ISO/TR 9769 or ASTM A751.

### 10.3.5 Re-check of product analyses — All groups

If the product analyses of both lengths of tubular product representing the heat fail to conform to the specified requirements, at the manufacturer's option either the heat shall stand rejected or all the remaining lengths in the heat shall be tested individually for conformance to the specified requirements. If only one of two samples fails, at the manufacturer's option either the heat shall stand rejected or two re-check product analyses shall be made on two additional lengths from the same heat. If both re-check product analyses conform to the requirements, the heat shall be accepted except for the length represented by the initial analysis which failed. If one or both of the re-check product analyses fail, at the manufacturer's option the entire heat shall be rejected or each of the remaining lengths shall be tested individually. In the individual testing of the remaining lengths in any heat, analyses for only the rejecting element or elements need be determined. Samples for re-check product analyses shall be taken in the same manner as specified for product analysis samples. The results of all re-check product analyses shall be provided to the purchaser when specified on the purchase agreement.

## 10.4 Tensile tests

### 10.4.1 Stress-relief temperature

For the purpose of tensile test frequency, stress-relief of tempered products shall not be considered "heat treatment" provided the stress-relief temperature is at least 56 °C (100 °F) below the final tempering temperature.

### 10.4.2 Heat-control tensile tests — Groups 1, 2 and 3

One tensile test shall be made as a control on each heat of steel used by the manufacturer for the production of pipe under this International Standard. For electric-welded pipe, these tensile tests shall be made on either the skelp or the finished pipe, at the option of the manufacturer.

A heat-control test made on a length of pipe may also be considered as a product test for the lot being tested.

### 10.4.3 Frequency of testing and location of test specimen — Casing and tubing

The frequency of testing for casing and tubing of all groups is defined in Table C.40 or Table E.40.

Additional requirements for PSL-2 and PSL-3 products are specified in Annex H.

The lengths for testing shall be selected at random and, when more than one test is required, the selection procedures shall provide samples representing the start and end of the heat-treat cycle (as applicable) and front and back ends of the tubes. When more than one test is required, the test specimens shall be from different lengths, except for upset pipe the test specimens may be taken from both ends of one length.

### 10.4.4 Frequency of testing and test specimen location — Coupling stock, couplings, pup joints and accessories

The frequency of testing is defined for coupling stock and couplings in Table C.41 or Table E.41 and for pup joints and accessories in Table C.42 or Table E.42.

For Group 1, Group 2 (except Grades C90 and T95) and Group 3, the test specimens from bar stock shall be taken from a location corresponding to the mid-wall of the finished products for accessories.

For Group 2 (Grades C90 and T95) and Group 4, tensile test specimens for coupling stock, couplings, pup-joint or accessory material heat-treated in tube length shall be removed from locations shown in Figure D.10.

No test is required for pup joints or accessories manufactured from a length of casing, tubing or coupling stock, provided that it has been previously tested and conforms to requirements and there is no subsequent heat treatment.

A heat-control test may also be considered as a product test for the lot being tested.

#### 10.4.5 Test specimens — General

Product-body tensile test specimens shall be either full-section specimens, strip specimens or round bar specimens, as shown in Figure D.9, at the option of the manufacturer. Strip specimens from seamless pipe and coupling stock shall be taken from any location about the pipe circumference at the option of the manufacturer. Round bar specimens shall be taken from the mid-wall. Strip specimens and round bar specimens from welded pipe shall be taken approximately 90° from the weld, or, at the option of the manufacturer, from the skelp parallel to the direction of rolling and approximately midway between the edge and the centre. Tensile test specimens for heat-treated pipe and coupling stock shall be removed from pipe subsequent to final heat treatment on the production line.

All strip specimens shall be approximately 38 mm (1.500 in) wide in the gauge length if suitable curved-face testing grips are used, or if the ends of the specimen are machined or cold-flattened to reduce the curvature in the grip area; otherwise they shall be approximately 19 mm (0.750 in) wide for pipe smaller than Label 1: 4, approximately 25 mm (1.000 in) wide for pipe from Label 1: 4 up to and including Label 1: 7-5/8, and approximately 38 mm (1.500 in) wide for pipe larger than Label 1: 7-5/8.

All product-body tensile specimens shall represent the full wall thickness of the product from which the specimen was cut, except for round bar tensile specimens, and shall be tested without flattening. Round bar specimens shall be 12,7 mm (0.500 in) in diameter when the product size allows, and 8,9 mm (0.350 in) in diameter for other sizes. For product sizes too small to allow a 8,9 mm (0.350 in) diameter specimen, round bar tensile specimens are not permitted. When elongation is recorded or reported, the record or report shall show the nominal width of the test specimen when strip specimens are used, the diameter and gauge length when round bar specimens are used, or shall state when full-section specimens are used.

#### 10.4.6 Test specimens — Additional requirements for couplings, pup joints and accessories — Grade Q125

In addition to the requirements in 10.4.5, longitudinal tensile test specimens shall be removed from coupling, pup-joint or accessory material and individually heat-treated coupling blanks, pup joints or accessories subsequent to final heat treatment. Tensile test specimens shall be either strip specimens or, if the wall thickness of the tubular is over 19,1 mm (0.750 in), a round specimen 12,7 mm (0.500 in) in diameter may be used as shown in Figure D.9.

Tensile test specimens for coupling, pup joint or accessory material heat-treated in coupling blank or individual lengths shall be removed from the piece as illustrated in Figure D.10. Reduced-section strip specimens may be used by agreement between purchaser and manufacturer.

#### 10.4.7 Test method

Tensile properties shall be determined by tests on longitudinal specimens conforming to the requirements of 10.4.5, ISO 6892 or ASTM A370, and 10.4.6 for the Grade Q125 products covered therein. Tensile tests shall be made with the specimens at room temperature. The strain rate during tensile testing shall be in accordance with the requirements of ISO 6892 or ASTM A370.

Tensile test machines shall have been calibrated within the 15 months preceding any test in accordance with the procedures of ISO 7500-1 or ASTM E4. Extensometers shall be calibrated within 15 months preceding any test in accordance with the procedures of ASTM E83. Records retention shall be in accordance with 13.5.



#### 10.4.8 Invalidation of tests

If any tensile specimen shows defective machining or develops flaws, it may be discarded and another specimen substituted.

#### 10.4.9 Re-tests — All products except couplings, coupling stock, pup joints or accessory materials in Grades C90, T95 and Q125

If a tensile test representing a lot fails to conform to the specified requirements, the manufacturer may elect to make re-tests on three additional lengths from the same lot.

If all of the re-tests conform to the requirements, the lot shall be accepted, excepting the failed length.

If more than one of the original test specimens fails or one or more of the re-test specimens fails to conform to the specified requirements, the manufacturer may elect to test each of the remaining lengths in the lot. Specimens for re-tests shall be taken in the same manner as specified in 10.4.5 and 10.4.6. For Grades M65, L80 and C95 the tensile re-test specimens shall be taken from the same end as the original test specimen.

Rejected lots may be re-heat-treated and tested as new lots.

#### 10.4.10 Re-tests — Couplings, coupling stock, pup joints or accessory materials in Grades C90, T95 and Q125

For material heat-treated in tube lengths, if a tensile specimen fails to conform to the specified requirements, the manufacturer shall either make tests on both ends of the tube in question or reject the length. No other additional testing shall be allowed to qualify a length of coupling, pup joint or accessory material. Both test results shall conform to the specified requirements or the length shall be rejected. Rejected lengths may be re-heat-treated and tested as new lots.

For material heat-treated in coupling blank or individual product lengths, if a tensile specimen fails to conform to the specified requirements, the manufacturer shall either re-heat treat that lot in question or make three additional tests from the lot in question. If one or more of them fails, the lot shall be rejected. The manufacturer may elect to re-heat-treat and test as new lots.

### 10.5 Flattening test

#### 10.5.1 General requirement for testing

Flattening tests shall be made for all welded pipe with  $D/t$  ratios as shown in Table C.23 or Table E.23.

In 10.5.2 to 10.5.7, the 0° position shall have the weld contacting the parallel plate (defined as 12 o'clock or 6 o'clock). The 90° position shall have the weld positioned at 3 o'clock or 9 o'clock.

#### 10.5.2 Frequency of testing

The frequency of testing shall be in accordance with Table C.44 or Table E.44.

#### 10.5.3 Test specimens

Test specimens shall be rings or crop ends not less than 63,5 mm (2½ in) long.

On pipe cut from multiple lengths of a coil, the test on one end of one piece shall represent a test on the adjacent end of the next piece of pipe. If the pipe is to be upset, the test specimen shall be taken from the tube prior to upsetting.

The test specimens may be cut before heat treating and given the same type heat treatment as the pipe represented. If lot testing is used, precaution shall be taken so that the test specimens can be identified with respect to the length of pipe from which they are cut. Each heat in each lot shall be subjected to a flattening test.

For electric-welded pipe that is full-body normalized, including pipe that is processed through a hot-stretch mill in accordance with the requirements in 6.2.1, flattening test specimens shall be obtained either prior to or after such treatment at the option of the manufacturer.

#### 10.5.4 Test method for Group 1 — Non-full-body heat-treated pipe

Test specimens shall be flattened between parallel plates. From each pair of flattening test specimens, one shall be flattened with the weld located in the 90° position and the other with the weld located in the 0° position. Test specimens shall be flattened until opposite walls of the pipe meet. No cracks or breaks shall occur anywhere in the specimen until the distance between the plates is less than that specified in Table C.23 or Table E.23; nor shall evidence of poor texture, incomplete fusion in the weld, laminations, burnt metal or extruded metal develop during the entire flattening process.

#### 10.5.5 Test method for Groups 1 and 2 — Full-body heat-treated pipe

Test specimens shall be flattened between parallel plates with the weld at the point of maximum bending; and, at the discretion of the inspector, separate flattening tests shall also be made with the weld located 90° from the point of maximum bending. Test specimens shall be flattened until opposite walls of the pipe meet. No cracks or breaks shall occur anywhere in the specimen until the distance between the plates is less than that specified in Table C.23 or Table E.23; nor shall evidence of poor texture, incomplete fusion in the weld, laminations, burnt metal or extruded metal develop during the entire flattening process.

#### 10.5.6 Test method for Grade P110 pipe and Grade Q125 casing

The requirements in A.6 (SR11) shall apply when ERW pipe and SR11 are specified on the purchase agreement (see 6.1).

#### 10.5.7 Re-tests

If either test specimen representing a single length of pipe fails to meet the requirements specified, the manufacturer may elect to make additional tests on specimens cut from the same end of the same length of pipe, until the requirements are met, except that the finished pipe shall not be shorter than 80 % of its length after the initial cropping. If any test specimen from a length of pipe representing a lot fails to conform to the requirements specified, the manufacturer may elect to repeat the tests on specimens cut from two additional lengths of pipe from the same lot. If such specimens conform to the specified requirements, all the lengths in the lot shall be accepted except the length initially selected for the test. If any of the re-test specimens fails to pass the specified requirements, the manufacturer may elect to test specimens cut from the individual lengths remaining in the lot. Specimens for re-tests shall be taken in the same manner as specified in 10.5.3. At the option of the manufacturer, any lot of pipe may be re-heat-treated and tested as a new lot.

### 10.6 Hardness test

#### 10.6.1 PSL requirements

Additional requirements for PSL-3 product are given in Annex H for Grades N80(Q), C95 and P110.

#### 10.6.2 Frequency of testing — General

The frequency of hardness testing for all products is specified in Table C.43 or Table E.43.

Additional hardness testing on the outside surface and through-wall hardness testing of pipe and upsets may be carried out as agreed between purchaser and manufacturer. Test procedures for this additional testing shall be agreed between purchaser and manufacturer.

No test is required for pup joints or accessories manufactured from a length of Grades M65, L80, C90, T95 or Q125 pup joint or accessory material previously tested, provided there is no subsequent heat treatment.

**10.6.3 Frequency of testing — Heat-control tests — Grades M65 and L80**

A hardness test block from each heat-control tensile test specimen shall be through-wall hardness-tested to verify conformance with hardness requirements.

A heat-control hardness test made on a product may also be considered as a product test for the lot being tested.

**10.6.4 Frequency of testing — Grades M65 and L80**

On pipe, coupling and accessory material, hardness testing shall be carried out at the same frequency as tensile testing for each of these products.

Additional requirements for PSL-3 products are specified in Annex H.

**10.6.5 Frequency of testing and test specimen location — Non-upset pipe — Grades C90 and T95**

On non-upset pipe, one through-wall hardness test in one quadrant shall be made on each length from one end of the pipe. Approximately 50 % of these test rings shall be cut from the front ends and approximately 50 % from the back ends of the pipe.

Additional requirements for PSL-3 product are given in Annex H.

**10.6.6 Frequency of testing and test specimen location — Upset pipe — Grades C90 and T95**

The pipe body of each length tensile-tested as required by 10.4.3 shall also be through-wall hardness-tested in all four quadrants to verify conformance to the requirements. The test frequency of the upset shall be one in every 20 lengths within each lot. One through-wall hardness test in four quadrants shall be made on one upset from that length in the section of that upset with the maximum wall thickness.

In addition to the through-wall hardness tests, an external-surface Brinell or Rockwell C-scale test shall be made on the pipe body and one upset of each length.

**10.6.7 Frequency of testing and test specimen location — Couplings, pup joints and accessories — Grades C90 and T95**

For thick-wall pipe used for making more than one coupling, pup joint or accessory, through-wall hardness tests shall be made on each of two test rings, one from each end.

For couplings, pup joints and accessories heat-treated in individual lengths, the piece having the highest surface hardness in the lot shall be selected for through-wall testing.

For individually heat-treated couplings, the hardness test ring shall be removed from the mid-length as shown in Figure D.10. For individually heat-treated pup joints and accessories, the hardness test ring may be removed from either the mid-length, as shown in Figure D.10, or from a prolongation.

Through-wall hardness tests shall be made in four quadrants.

**10.6.8 Frequency of testing — Grade Q125**

For casing, through-wall hardness tests shall be made on three lengths per lot. The lengths for testing shall be selected at random, provided the selection procedure provides samples representing the start and end of the heat-treat cycle and front and back ends of the tubes.

For coupling, pup-joint or accessory material heat-treated in tube length, one end of each length shall be through-wall hardness tested (approximately 50 % each end).

For couplings, pup joints or accessories heat-treated in coupling blank or individual length, one piece from each lot shall be through-wall hardness tested.

Through-wall hardness tests shall be made in one quadrant.

Additional requirements for PSL-3 product are given in Annex H.

### 10.6.9 Test specimens

Test specimens for hardness testing shall be removed from products according to locations shown in Figure D.10, or removed from the end of the length or from a prolongation as specified in this International Standard. For all grades, through-wall hardness tests shall be made on either rings or blocks.

Through-wall hardness tests for one quadrant shall be made on a block from a ring or the tensile test specimen. Through-wall hardness tests for four quadrants shall be made on a ring or on test blocks cut from a ring. Through-wall hardness test rings shall be prepared as specified in Figure D.11 in either one or four quadrants.

Hardness test surfaces shall be ground parallel and smooth, and shall be free from oxide scale, foreign matter and lubricants.

### 10.6.10 Test method

Hardness tests shall be made in accordance with ISO 6506-1 or ASTM E10 for Brinell hardness tests and ISO 6508-1 or ASTM E18 for Rockwell hardness tests.

Two types of hardness test are used in these standards:

- a) external surface tests involving a single indentation and
- b) through-wall hardness tests involving multiple indentations.

External surface tests may be made using either the Rockwell or the Brinell method, and may be used for product acceptance and process control as specified in this International Standard.

Through-wall hardness tests shall be made by the Rockwell method and used for product acceptance for maximum hardness and allowable hardness variation, and for as-quenched hardenability. Through-wall hardness tests shall be made transverse to the axis of the product. When the hardness ring is removed from the end of the length, the hardness tests shall be made on the side of the specimen farthest from the end of the piece (that is, away from the quenched end surface). The first indentation on each hardness block or ring quadrant may be disregarded in order to reduce the possibility of errors.

When the specified wall thickness of a product is less than 7,62 mm (0.30 in), three indentations in the mid-wall of the specimen are acceptable for through-wall hardness tests. For all other products, in each quadrant three indentations shall be made in each of three positions. The hardness numbers from three indentations in each position, i.e. outer, mid-wall and inner, shall be combined to give a mean hardness number for each position. A through-wall hardness test comprises mean hardness numbers for each position in a quadrant, in either one or four quadrants as specified in this International Standard.

Indentations on the outer and inner positions shall be made between 2,54 mm (0.10 in) and 3,81 mm (0.15 in) from the applicable outer or inner surface, but not closer than 2½ indentation diameters from the centre of an indentation to the edge of the surface. Indentations shall be no closer than 3 indentation diameters from another indentation, measured centre to centre. Alternate spacing of rows of indentations is permitted for thin-wall pipe.

The through-wall hardness test is usually made using the Rockwell C-scale. It is acceptable to use the Rockwell C-scale on materials having a hardness below 20 HRC. Care should be exercised when evaluating hardness below 20 HRC because of a potential lack of precision, but nevertheless these results may be used to determine hardness. The use of the Rockwell B-scale on materials having a hardness below 20 HRC is at

the manufacturer's option or as specified on the purchase agreement. Rockwell hardness numbers and mean hardness numbers shall be reported in Rockwell C, from actual or converted numbers, to the first decimal place. When A.9 SR 15 is specified on the purchase agreement, the manufacturer shall provide these data to the purchaser.

Hardness conversions shall be made in accordance with an appropriate conversion table selected by the manufacturer, unless otherwise specified on the purchase agreement.

Brinell hardness numbers shall be rounded to three significant digits and the test conditions reported if test forces other than 29,42 kN (3 000 kgf), ball diameters other than 10 mm and test force application duration other than 10 s to 15 s are used.

Laboratory Rockwell C scale shall be used as a referee method in cases of disagreement.

#### **10.6.11 Invalidation of tests**

If any hardness specimen shows defective machining or develops flaws, it may be discarded and another specimen substituted.

#### **10.6.12 Periodic checks of hardness-testing machines**

Periodic checks of testing machines shall be made using the procedures in ISO 6506-1 or ASTM E18 part B for Brinell hardness test machines, or ISO 6508-1 or ASTM E10 part B for Rockwell hardness test machines; both relevant ISO texts are entitled "Procedure for periodic checks of the testing machines by the user" and ASTM paragraphs entitled "Procedure for Periodic Checks by the User". The testing machine shall be checked at the beginning and end of a continuous run of testing and at such times as are required to assure the operator of the equipment and the purchaser (or his representative) that the machine is satisfactory. In any event, checks should be made at least every 8 h of a continuous run of testing. Checks shall be made on standardized test blocks with the following hardness ranges:

- a) Group 2: 20 HRC to 25 HRC
- b) Grade Q125: 25 HRC to 35 HRC.

If the checks indicate that the testing machine results are unsatisfactory, the machine shall be verified by indirect verification using standardized test blocks according to the procedures in ISO 6506-2 or ASTM E18 part B for Brinell hardness test machines, or ISO 6508-2 or ASTM E10 part B for Rockwell hardness test machines.

#### **10.6.13 Re-tests — Grades M65 and L80**

For Grades M65 and L80 products, if a through-wall hardness test specimen representing a lot fails to conform to the specified requirements, the manufacturer may elect to make re-tests on two additional lengths from the same lot from the same end as the original test specimen. If all the re-tests conform to the requirements, the lot shall be accepted except the failed length. If one or more of the re-test specimens fails to conform to the specified requirements, the manufacturer may elect to test each of the remaining lengths in the lot or reject the lot.

#### **10.6.14 Re-tests — Grades C90 and T95 products except for coupling blanks, pup joints or accessories heat-treated after cutting to individual lengths**

For Grades C90 and T95, if any mean hardness number falls between 25,4 HRC and 27,0 HRC inclusive, three additional indentations shall be made in the immediate area to determine a new mean hardness number. If the new mean hardness number does not exceed 25,4 HRC, the piece shall be accepted. If the new mean hardness number exceeds 25,4 HRC, the piece shall be rejected.

**10.6.15 Re-tests — Grades C90 and T95 coupling blanks, pup joints or accessories heat-treated after cutting to individual lengths**

For Grades C90 and T95 coupling blanks, pup joints or accessories heat-treated after cutting to blank or individual lengths, if the hardness test specimen representing a lot fails to conform to the specified requirement, the piece or length shall be rejected. The manufacturer shall either re-heat-treat the lot or make three additional tests from the lot using the same selection criteria for the pieces selected in the original test. If any of these three re-tests fail, the entire heat-treat lot shall be rejected.

**10.6.16 Re-tests — Grade Q125 — General**

If the allowable hardness variation as specified in Table C.6 or Table E.6 is exceeded on a specimen, the surface in that quadrant may (at the option of the manufacturer) be re-ground below the initial hardness impressions and re-tested. Only one re-grind and re-test is allowed for each specimen. After re-test, product that fails to comply with the specified requirements shall be rejected.

**10.6.17 Re-tests — Grade Q125 — Casing**

If more than one of the initial three lengths required to qualify a lot of casing is rejected, then the manufacturer may elect to test each of the remaining lengths in the lot. Re-tests of these lengths shall only be allowed as specified in 10.6.16.

If only one of the initial three lengths required to qualify a lot of casing is rejected, then an additional three lengths may be tested to attempt to qualify the lot of casing. Re-tests of the additional lengths shall only be allowed as specified in 10.6.16. If any of the additional three lengths required to qualify a lot of casing is rejected, then the manufacturer may elect to test each of the remaining lengths in the lot or reprocess the lot (that is, five of the six lengths tested shall meet the requirements of 7.8 and Table C.6 or Table E.6 to qualify the casing on a lot basis).

**10.6.18 Re-tests — Grade Q125 — Couplings, pup joints and accessories**

In the case of couplings, pup joints or accessories heat-treated as coupling blank or individual pieces, if the hardness variation as specified in 7.8 and Table C.6 or Table E.6 is exceeded, the manufacturer may carry out through-wall hardness testing of three more pieces from the lot in question. If a specimen from any one of the three pieces exceeds the allowable hardness variation, the lot shall be rejected.

**10.6.19 Rejected lots — Groups 2 and 4**

For all products, rejected lots may be reprocessed (that is, heat-treated again) and hardness-tested again as new lots.

**10.7 Impact test****10.7.1 Sampling — Grades J55, K55 and N80 Type 1**

For accessory material, when required in 7.6, and for coupling stock and accessory material, one set of test specimens shall be taken from each lot.

**10.7.2 Sampling — Grade M65 pipe**

One set of test specimens shall be taken from each lot.

**10.7.3 Sampling — Grades N80Q, L80, C90, C95, T95 and P110**

For pipe, one set of test specimens shall be taken from each lot unless compliance with the requirements is qualified by a documented procedure, see 7.5.6. If A.10 (SR16) is specified in the purchase agreement, testing is mandatory.

For accessory material, when required in 7.6, and for coupling stock and couplings, one set of test specimens shall be taken from each lot.

#### **10.7.4 Sampling and test specimen location — Grade Q125**

For casing, three lengths per lot shall be tested. The lengths for testing shall be selected at random, provided the selection procedures give samples representing the start and end of the heat-treat cycle and the front and back ends, as processed, of the casing.

For coupling stock, pup-joint or accessory material heat-treated in tube length, one piece from an end of each length shall be tested. Front and back ends, as processed, shall be tested on an approximately 50 % basis.

For couplings, pup joints or accessories heat-treated in coupling blank or individual length, one piece from each lot shall be tested.

#### **10.7.5 Test specimens**

For orientation of longitudinal and transverse specimens, see Figure D.12.

Impact test specimens shall not be machined from flattened tubulars.

When testing EW pipe using a transverse test specimen, the weld line shall be positioned at the notch in the CVN test specimen.

The surface of the finish-machined transverse test specimen may contain the outside diameter curvature of the original tubular product, provided that the requirements of Figure D.13 are met. These specimens shall be used only to permit the use of a transverse specimen of maximum possible thickness consistent with Table C.9 or Table E.9.

#### **10.7.6 Test method**

CVN impact tests shall be conducted as specified in ASTM A370 and ASTM E23.

For the purpose of determining conformance with these requirements, the observed result of a test shall be rounded to the nearest whole number. The impact energy value for a set of test specimens (i.e. average of three tests) shall be expressed as a whole number, rounded if necessary. Rounding shall be in accordance with the rounding method of ISO 31-0 or ASTM E29.

#### **10.7.7 Invalidation of tests**

Any test specimen that shows defective preparation or material imperfections unrelated to the intent of the test, whether observed before or after testing, may be discarded and be replaced by another specimen from the same length of product. Specimens shall not be judged defective simply because they failed to exhibit the minimum absorbed energy requirement (see 10.7.7 to 10.7.9).

#### **10.7.8 Re-test of a length — All groups**

If the results of more than one specimen are below the specified minimum absorbed energy requirement, or if the result of one specimen is below two-thirds of the minimum specified absorbed energy requirement, a re-test of three additional specimens shall be made from the same length. The impact energy of each of the re-test specimens shall equal or exceed the specified minimum absorbed energy requirement or the length shall be rejected.

#### **10.7.9 Replacement of a reject length — All groups**

If the results of a test do not meet the requirements of 7.4 to 7.6, as applicable, and do not qualify for re-testing in accordance with 10.7.7, then an additional three test specimens shall be removed from each of three additional lengths from the lot. If all the additional lengths tested conform to the requirements, then the lot shall be qualified except for the length that was initially rejected. If one or more of the additional lengths

tested fail to conform to the specified requirements, the manufacturer may elect to test individually the remaining lengths in the lot or re-heat-treat and test the lot as a new lot.

#### **10.7.10 Multiple length rejection — Grade Q125**

If more than one of the initial three lengths required to qualify a lot of casing is rejected, re-testing to qualify the lot is not permitted. The manufacturer may elect to test each of the remaining pieces in the lot, or to re-heat-treat and test the lot as a new lot.

### **10.8 Grain size determination — Grades C90 and T95**

#### **10.8.1 Sampling**

Grain size determination shall be made on each as-quenched hardenability test sample.

#### **10.8.2 Test method**

Grain size shall be determined by metallurgical evaluations such as the McQuaid-Ehn Test or other methods as specified in ISO 643 or ASTM E112.

### **10.9 Hardenability — Grades C90 and T95**

Hardenability shall be determined on one sample per production run or heat-treatment practice. Through-wall hardness tests in four quadrants shall be made at the beginning of each order and thereafter whenever a size change occurs or the austenitization and quenching process conditions change significantly.

### **10.10 Sulfide stress-cracking test — Grades C90 and T95**

ANSI-NACE Test Method TM0177-96 shall be used in conjunction with the requirements of 7.14 to determine the room temperature sulfide stress-cracking resistance of Grades C90 and T95 products. The level of resistance to sulfide stress-cracking shall be measured using either the tensile method (Method A), the bent beam method (Method B) or the DCB test method (Method D).

For Method A, full-size smooth tensile test specimens shall be used except where sub-size smooth tensile test specimens are required because of pipe geometry constraints.

### **10.11 Metallographic evaluation — EW Grades P110 and Q125**

A metallographic evaluation shall be performed at the beginning of the welding process for each size of tubular, again at least each 4 h during the welding and after any substantial interruption of the welding process. The samples shall be obtained prior to heat treatment.

The manufacturer shall have objective criteria to evaluate the acceptability of the electric-welded zone.

Additional requirements for PSL-2 and PSL-3 product are given in Annex H.

### **10.12 Hydrostatic tests**

#### **10.12.1 Hydrostatic test procedures**

Each length of pipe shall be tested full-length subsequent to upsetting (if applicable) and subsequent to final heat treatment (as applicable) to at least the hydrostatic pressure specified in 10.12.2 without leakage. The test conditions shall be held for not less than 5 s at full pressure. For electric-weld pipe, the pipe seam shall be inspected for leaks and sweats while under full test pressure. The entity performing the threading shall perform a hydrostatic test (or arrange for such a test) on the full length of pipe unless previously tested full



length to at least the pressure required for the final end condition. The test shall be performed in one of the following conditions:

- a) plain-end non-upset provided no upsetting or further heat treatment is to be performed;
- b) plain-end non-upset after heat treatment;
- c) plain-end after upsetting, provided no further heat treatment is to be performed;

If such pipe has been tested full length to the threaded-and-coupled test pressure in the plain-end condition prior to upsetting, the test of the upset portion may be made after upsetting through the use of an end tester which seals behind the portion of the pipe which was heated for upsetting.

- d) plain-end upset after heat treatment;
- e) threaded without couplings applied;
- f) threaded and coupled with couplings applied power-tight;
- g) pup joints, after finish machining and any heat treatment, shall be tested either plain-end or threaded.

For pipe requiring heat treatment, the test shall take place after the final heat treatment. The test pressure shall be at least the threaded-and-coupled test pressure for all pipe with threaded ends. Pipe furnished with extreme-line end-finish shall have been hydro-tested to at least the extreme-line test pressure in one of the above conditions.

The tester shall be equipped with devices for assuring that the specified test pressure and time interval requirements are met. The test pressure-measuring device shall be calibrated by means of a deadweight tester, or equivalent, within four months prior to each use. Calibration and verification records retention shall be as given in 13.4.

NOTE 1 Martensitic chromium steels are sensitive to galling. Special precautions may be necessary for thread surface treatment and/or lubrication to minimize galling during hydrostatic testing (plug application and removal).

NOTE 2 Various types of hydro-test systems are available. The entity performing the hydro-test is responsible for establishing a test procedure which minimizes the potential for damage to the pipe and threads of both the pipe and coupling.

### 10.12.2 Hydrostatic test requirements

Pipe shall comply with the test requirements for the size, grade and end-finish detailed in Tables C.45 to C.61 inclusive or Tables E.45 to E.61 inclusive.

Additional requirements for PSL-2 and PSL-3 product are given in Annex H.

For threaded pipe, the hydrostatic test pressures shall be standard pressures calculated as described in 10.12.3, or a higher pressure as agreed upon between the purchaser and the entity performing the threading.

For plain-end pipe except Grade Q125, the hydrostatic test pressures shall be the pressures calculated as described in 10.12.3, or a higher pressure as agreed upon between purchaser and manufacturer. This does not preclude conducting subsequent hydrostatic tests at a fibre stress not exceeding 80 % of specified minimum yield strength, in accordance with the formula listed below. Failure to pass this hydrostatic test without leakage is basis for rejection.

Plain-end Grade Q125 pipe shall be tested as agreed upon between purchaser and manufacturer.

Testing is not required on coupling stock, accessories or Grade Q125 pup joints, except by agreement between purchaser and manufacturer.

NOTE 1 Hydrostatic test requirements for plain-end casing liners are included in Table C.46 or Table E.46.

NOTE 2 The hydrostatic test pressures specified herein are inspection test pressures, are not intended as a basis for design, and do not necessarily have any direct relationship to working pressures.

NOTE 3 The user should be aware that couplings having API threads with special clearance or standard outside diameters may leak at a pressure less than the alternative test pressure for the plain-end or threaded-and-coupled tube, due to inadequate bearing pressure between the coupling and pin.

### 10.12.3 Test pressure calculation

The standard hydrostatic test pressures shall be calculated using the following formula, rounded to the nearest 0,5 MPa (100 psi) and limited to a maximum of 69,0 MPa (10 000 psi):

$$p = (2 \cdot f \cdot YS_{\min} \cdot t) / D$$

where

$p$  is the hydrostatic test pressure, in megapascals (pounds per square inch);

$f$  is a factor: 0,6 (0.6) for Grades H40, J55 and K55 larger than Label 1: 9-5/8 or 0,8 (0.8) for all other grades and sizes;

$YS_{\min}$  is the specified minimum yield strength for the pipe body, in megapascals (pounds per square inch);

$D$  is the specified outside diameter, in millimetres (inches);

$t$  is the specified wall thickness, in millimetres (inches).

NOTE The above formula for hydrostatic test pressure is applicable to both SI and USC units.

Lower test pressures may be allowed only due to physical limitations of the test equipment. The manufacturer shall have a documented design basis to establish the physical limitations of the hydrostatic test equipment. If the calculated test pressure (based on the outside diameter, thickness and grade) is greater than the physical capability of the hydrostatic test equipment, the manufacturer, upon agreement with the purchaser, shall use a test pressure equal to the physical capability of the test equipment. However, the hydrostatic test capability may be less than 20,5 MPa (3 000 psi) only for those products where the calculated test pressure is less than 20,5 MPa (3 000 psi).

Alternative test pressures for Grades H40, J55 and K55 in sizes larger than Label 1: 9-5/8 are calculated using a factor  $f$  of 0,8. For Grades P110 and Q125, when the calculated test pressure exceeds 69,0 MPa (10 000 psi), the standard test pressure is limited to 69,0 MPa (10 000 psi) and the alternative test pressure is as calculated. The alternative test pressures are given in parentheses in the tables. Alternative test pressures shall be used when specified on the purchase agreement and when agreed by the purchaser and manufacturer.

The hydrostatic test pressures for threaded and coupled pipe are calculated from the above formula, except where a lower pressure is required to avoid leakage due to insufficient coupling strength or interface pressure between pipe and coupling threads. The lower pressures shall be calculated for threaded and coupled pipe as specified in ISO 10400 or API Bull 5C3.

## 10.13 Dimensional testing

### 10.13.1 Diameter — Accuracy of measurement

For measurement of diameter in SI units, an accuracy of two decimal places shall be used for sizes Label 1: 6-5/8 and smaller, and an accuracy of one decimal place shall be used for sizes larger than Label 1: 6-5/8. Diameter measurements in USC units shall have an accuracy of three decimal places.

**NOTE** In this International Standard, the specified pipe outside diameter, expressed in SI units, always uses two decimal places for design purposes to ensure interchangeability of actual product regardless of whether it was produced using dimensions in SI or USC units.

### 10.13.2 Diameter measurement

For pipe and coupling stock, the manufacturer shall demonstrate conformance to the requirements of 8.11.1 in a single diametric plane at a minimum frequency of one length of pipe or coupling stock per one hundred lengths.

For non-upset pipe and coupling stock, the measurements shall be made with pi-tapes (wrap tapes), micrometers, callipers or snap gauges. For upset casing and Label 1: 2-3/8 and larger external upset tubing, the measurements shall be made with micrometers, callipers or snap gauges.

The manufacturer shall measure the diameter of both ends of pipe ordered as plain-end or coupling stock at a minimum frequency of one per one hundred.

If any pipe fails to meet the requirements, the provisions of 10.13.3 shall apply.

In case of dispute of the minimum diameter requirements, micrometer measurements shall govern. In case of dispute of the maximum diameter requirements, pi-tape (wrap tape) measurements shall govern. When using a micrometer, three measurements shall be made in the non-conforming area and averaged. The average of the three readings shall be used to determine the conformance of the diameter.

### 10.13.3 Diameter re-tests

If any pipe or coupling stock fails to meet the specified diameter requirements when measured with callipers, micrometers or snap gauges, the manufacturer may elect to make measurements on three additional lengths from the same lot. If any pipe or coupling stock fails to meet the specified diameter requirements when measured with a pi-tape, and unless the manufacturer can show evidence of a specific problem affecting only that pipe or coupling stock, each pipe or coupling stock from the same lot shall be measured for conformance.

If all re-test measurements conform to the specified diameter requirements, all lengths in the lot shall be accepted except the length initially selected for measurement. If any of the re-test measurements fails to meet the specified requirements, the manufacturer may elect to measure the individual lengths remaining in the lot. Individual lengths which fail to pass the specified requirements may be cut back and measured again for conformance.

At the option of the manufacturer, any lot of pipe or coupling stock may be reprocessed and measured as a new lot.

**NOTE** Once the pipe or coupling stock has proceeded past its last manufacturing quality control point for diameter, some deviations in the maximum and minimum diameters can occur due to handling and storage, and should not be cause for rejection, provided the average diameter as measured by a pi-tape is within the diameter tolerances.

### 10.13.4 Wall thickness

Each length of pipe or coupling stock shall be measured to verify conformance with wall thickness requirements. Wall thickness measurements shall be made with a mechanical calliper, a go/no-go gauge or with a properly calibrated NDE device of appropriate accuracy.

Additional requirements for PSL-2 and PSL-3 product are given in Annex H.

In case of dispute, the measurement determined by use of the mechanical calliper shall govern. The mechanical calliper shall be fitted with contact pins having circular cross-sections of 6,4 mm ( $\frac{1}{4}$  in) diameter. The end of the pin contacting the inside surface of the pipe shall be rounded to a maximum radius of 38,1 mm ( $1\frac{1}{2}$  in) for pipe sizes Label 1: 6-5/8, and larger, a maximum radius of  $d/4$  for pipe less than Label 1: 6-5/8, with a minimum radius of 3,2 mm ( $1/8$  in). The end of the pin contacting the outside surface of the pipe shall be either flat or rounded to a radius of not less than 38,1 mm ( $1\frac{1}{2}$  in).

To ensure conformance to wall thickness requirements, all seamless pipe and coupling stock requiring electromagnetic or ultrasonic inspection as specified in Table C.62 or Table E.62 shall have the wall thickness verified in a helical or longitudinal path over the length of the pipe or coupling stock, excluding end areas not covered by automated systems, in accordance with a documented procedure. The location of the wall-thickness verification equipment shall be at the discretion of the manufacturer.

Accessories shall have the wall thickness verified if so specified in the purchase agreement.

#### 10.13.5 Drift test

All drift testing shall be performed with a drift mandrel containing a cylindrical portion conforming to the requirements shown in Tables C.31 and C.32 or Tables E.31 and E.32 as applicable. See 8.10 for requirements for casing used as tubing. The ends of the drift mandrel extending beyond the specified cylindrical portion shall be shaped to permit easy entry into the pipe. The drift mandrel shall pass freely through pipe by the use of a manual or power drift procedure. In case of dispute, the manual drift procedure shall be used. Pipe shall not be rejected until it has been drift-tested when it is free of all foreign matter and properly supported to prevent sagging.

#### 10.13.6 Length

When pipe is furnished with threads and couplings, the length shall be measured to the outer face of the coupling or, if measured without couplings, proper allowance shall be made to include the length of coupling. For extreme-line casing and integral-joint tubing, the length shall be measured to the outer face of the box end. For pup joints and accessories, the length shall be measured from end to end.

#### 10.13.7 Mass (weight) determination

Each length of casing and each length of tubing in sizes Label 1: 1.660 and larger shall be weighed separately. Lengths of tubing in sizes smaller than Label 1: 1.660 shall be weighed either individually or in convenient bundles.

The pipe manufacturer applying the markings to the pipe body (see Clause 11) shall be responsible for weighing the pipe to determine conformance with mass tolerance. The pipe may be weighed plain-end, upset, non-upset, threaded, or threaded and coupled. Threaded-and-coupled pipe may be weighed with the couplings screwed on or without couplings, provided proper allowance is made for the mass of the couplings. Threaded-and-coupled pipe, integral-joint pipe, and pipe shipped without couplings shall be weighed with or without thread protectors if proper allowances are made for the mass of the thread protectors. Weighing of a pipe by a threader is not mandatory.

NOTE The densities of martensitic chromium steels (L80 Types 9Cr and 13Cr) are different from carbon steels. The masses shown are therefore not accurate for martensitic chromium steels. A mass correction factor of 0,989 may be used.

#### 10.13.8 Straightness

All pipe and coupling stock shall be visually examined. The straightness of questionably bent pipes or crooked extremities shall be measured as follows:

- a) for Label 1: 4-1/2 and larger, using a straightedge or taut string (wire) from one end of the pipe to the other end;
- b) using a straightedge with a minimum length of 1,8 m (6 ft) of which at least 0,3 m (1 ft) shall contact the pipe surface beyond the extent of the hooked extremity or an equivalent method. In the case of dispute, the straightedge measurement shall govern.

The taut string and straightedge shall be positioned to highlight the maximum deviation.

Deviation from the straight, or chord height, shall not exceed the requirements in 8.9. See Figures D.14 and D.15.

Measurement of the deviation shall not be made in the plane of the upset, the upset fade-away or the coupling.

**10.13.9 Internal upset**

Inspection of the internal upset configuration shall be made with a 90° hook-type tool. The contact pin shall have a circular cross-section of 4,8 mm (3/16 in) diameter that is visually determined to be attached perpendicular to the handle. The end of the pin contacting the inside surface of the pipe shall be rounded to a height (between the radius tangent point and the vertical surface of the contact point shaft) that shall not exceed 0,30 mm (0.012 in). The contact point radius shall not exceed the inside radius of the pipe being inspected. Sharp edges on the contact point shall be removed. See Figure D.26. The 90° hook-type tool contact point should be maintained perpendicular to the longitudinal axis of the pipe while the contact point is passed axially throughout the ID upset transition length. Pressure on the contact point shall be no greater than the pressure created by the mass of the 90° hook-type tool.

**10.14 Visual inspection****10.14.1 General**

All visual inspection shall be carried out by trained personnel with satisfactory visual acuity to detect surface imperfections. Documented lighting standards for visual inspection shall be established by the manufacturer. The minimum illumination level at the inspection surface shall be 500 lx (lux) (50 foot-candles).

All visual inspection may be at any appropriate point in the manufacturing process, except that end-area inspection, when required, shall be after all heat treatment.

**10.14.2 Pipe body and coupling stock (excluding pipe ends)**

Each length of pipe or coupling stock shall be visually inspected over the entire outside surface for the detection of imperfections. For roll marks see 6.3.2.

**10.14.3 Pipe ends**

Pipe ends shall be visually inspected on the outside surface for a minimum distance of 450 mm (18 in).

For non-upset products, pipe ends shall be visually inspected on the inside surface for a minimum distance of  $2,5 D$  or 450 mm (18 in), whichever is the lesser.

For upset products, pipe ends shall be visually inspected on the inside surface for a minimum distance of the length of upset including the run-out interval.

If another method is applied with demonstrated capability of detecting defects as defined in 8.13, visual inspection is not required.

If end cropping is performed to remove defects, the end of the pipe revealed after cropping shall be subjected to a repeat internal surface inspection as previously performed.

**10.14.4 Disposition**

Surface imperfections disclosed by visual inspection shall be treated in accordance with 10.15.16.

**10.15 Non-destructive examination (NDE)****10.15.1 General**

Subclause 10.15 specifies the NDE requirements and inspection levels for seamless and electric-welded pipe and accessories and for coupling stock. A summary of the required NDE operations for seamless pipe, coupling stock and the body of welded pipe is given in Table C.62 or Table E.62. All pipe, coupling stock and accessories that require NDE (except visual inspection) shall be inspected full length (end-to-end) for defects.

The NDE tube standards referenced in this clause are based on traditional proven NDE methods and techniques practised and adopted world-wide for the inspection of tubular products. However, other NDE methods/techniques, that have demonstrated capability in detecting defects as defined in 8.13, can be used. Records in accordance with 10.15.4 shall be maintained.

At the discretion of the manufacturer, the notches referenced in Table C.63 or Table E.63 may be oriented at an angle such that detection of defects typical of the manufacturing process is optimized. The technical justification for modification of the orientation shall be documented.

If the provisions for purchaser inspection of pipe and/or witnessing of NDE operations are stated on the purchase agreement, they shall be in accordance with Annex B.

The inspections performed in accordance with 10.15, with the equipment calibrated to the reference indicators in Table C.64 or Table E.64, should not be construed as assuring that the material requirements in 8.13 have been met.

### 10.15.2 NDE personnel

All NDE operations (except visual inspection) referred to in this International Standard shall be conducted by NDE personnel qualified and certified in accordance with ISO 11484 or ASNT SNT-TC-1A:1984.

### 10.15.3 Reference standards

Ultrasonic and electromagnetic inspection systems for verification, other than wall thickness verification, shall use reference standards containing notches or holes as described in Tables C.63 and C.64 or Tables E.63 and E.64 to verify equipment response from artificial reference indicators.

The manufacturer may use any documented procedures to establish the reject threshold for ultrasonic or electromagnetic inspection, provided the artificial reference indicators described in Tables C.63 and C.64 or Tables E.63 and E.64 can be detected dynamically under normal operating conditions. Such detection capability shall be demonstrated dynamically. At the option of the manufacturer, this may be performed either on line or off line.

Tables C.63 and C.64 or Tables E.63 and E.64 list the acceptance (Inspection) levels and associated artificial reference indicators that manufacturers shall use in establishing thresholds for sorting pipe that may contain defects as defined in 8.13. The reference indicators, used during automated ultrasonic or electromagnetic inspection, are not to be construed as being the defect sizes defined in 8.13, or be used by those other than the manufacturer as the only basis for pipe rejection.

When calibrating EMI equipment using drilled holes, the inspection system shall be capable of producing signals from both OD and ID notches that are equal to or greater than the reject threshold established using the drilled hole. Records in accordance with 10.15.4 shall be maintained.

### 10.15.4 NDE system capability records

The manufacturer shall maintain NDE system records verifying the system(s) capabilities in detecting the reference indicators used to establish the equipment test sensitivity.

The verification shall cover, as a minimum, the following criteria:

- a) coverage calculation (i.e. scan plan), including wall thickness verification;
- b) capability for the intended wall thickness;
- c) repeatability;
- d) transducer orientation that provides detection of defects typical of the manufacturing process (see 10.15.1);

- e) documentation demonstrating that defects typical of the manufacturing process are detected using the NDE methods in Table C.62 or Table E.62;
- f) threshold-setting parameters.

In addition, the manufacturer shall maintain documentation relating to:

- g) NDE system operating procedures;
- h) NDE equipment description;
- i) NDE personnel qualification information;
- j) dynamic test data demonstrating the NDE system/operation capabilities under production test conditions.

#### **10.15.5 Pipe body or coupling stock inspection — General**

Unless otherwise agreed, all required NDE operations (except visual inspection, but including the final end-area inspection in accordance with 10.15.12) for pipe and coupling stock shall be carried out after final heat treatment and rotary straightening operations, with the following exceptions:

- a) certain types of pup joint (see 10.15.11);
- b) when more than one pipe-body NDE method is applied, one of these (other than ultrasonic inspection) may take place prior to heat treatment/rotary straightening.

Additional requirements for PSL-2 and PSL-3 product are given in Annex H.

#### **10.15.6 Full-body NDE of casing and tubing — Grades N80Q, M65, L80 and C95**

All pipe shall be inspected for the detection of longitudinal imperfections on the outside and inside surfaces to acceptance level L4 by one or more of the following methods:

- a) ultrasonic testing in accordance with ISO 9303 or ASTM E213;
- b) flux leakage testing in accordance with ISO 9402 or ASTM E570;
- c) eddy current concentric coil testing in accordance with ISO 9304 or ASTM E309;
- d) for pipe outside surface, magnetic particle inspection in accordance with ISO 13665 or ASTM E709.

Additional requirements for PSL-2 and PSL-3 product are given in Annex H.

#### **10.15.7 Full-body NDE of casing and tubing — Grade P110 to A.10 (SR16)**

All pipe shall be inspected for the detection of both longitudinal and transverse imperfections on the outside and inside surfaces to acceptance level L4 by one or more of the following methods:

- a) ultrasonic testing in accordance with ISO 9303 or ASTM E213 (longitudinal) and ISO 9305 or ASTM E213 (transverse);
- b) flux leakage testing in accordance with ISO 9402 or ASTM E570 (longitudinal) and ISO 9598 or ASTM E570 (transverse);
- c) eddy current concentric coil testing in accordance with ISO 9304 or ASTM E309.

Additional requirements for PSL-3 product are given in Annex H.

### 10.15.8 Full-body NDE of casing and tubing — Grade P110 and Grade P110 to A.10 (SR16) and A.3 (SR2)

All pipe shall be inspected for the detection of both longitudinal and transverse imperfections on the outside and inside surfaces to acceptance level L2 by one or more of the following methods:

- a) ultrasonic testing in accordance with ISO 9303 or ASTM E213 (longitudinal) and ISO 9305 or ASTM E213 (transverse);
- b) flux leakage testing in accordance with ISO 9402 or ASTM E570 (longitudinal) and ISO 9598 or ASTM E570 (transverse);
- c) eddy current concentric coil testing in accordance with ISO 9304 or ASTM E309.

Additional requirements for PSL-3 product are given in Annex H.

### 10.15.9 Full-body NDE of casing and tubing — Grades C90, T95 and Q125

All pipe shall be ultrasonically inspected for the detection of both longitudinal and transverse imperfections on the outside and inside surfaces to acceptance level L2 in accordance with ISO 9303 or ASTM E213 (longitudinal) and ISO 9305 or ASTM E213 (transverse)

In addition, all pipes shall be inspected for the detection of imperfections on the outside surface by one of the following methods:

- a) flux leakage testing to acceptance level L2 in accordance with ISO 9402 or ASTM E570 (longitudinal) and ISO 9598 or ASTM E570 (transverse);
- b) eddy current testing to acceptance level L2 in accordance with ISO 9304 or ASTM E309;
- c) magnetic particle inspection in accordance with ISO 13665 or ASTM E709.

### 10.15.10 NDE of the weld seam of welded pipe

Unless otherwise agreed, the timing of the weld seam inspection of welded pipe shall be at the manufacturer's discretion, with the exception that for quenched and tempered welded pipe, the weld seam inspection shall take place after final heat treatment and rotary straightening operations.

NDE of the weld seam of electric-welded pipe shall be carried out using inspection equipment capable of full volumetric inspection over a 3 mm (1/8 in) wide zone centred on the fusion line.

For all grades of Groups 1 and 2, the weld seam shall be inspected for the detection of longitudinal imperfections by one or more of the following methods:

- a) ultrasonic testing to acceptance level L3 in accordance with ISO 9764 or ASTM E273 or ISO 9303 or ASTM E213;
- b) flux leakage testing to acceptance level L3 in accordance with ISO 9402 or ASTM E570;
- c) eddy current testing to acceptance level L3 in accordance with ISO 9304 or ASTM E309.

For Grades P110 and Q125, the requirements of A.6.5 (SR11.5) shall apply.

Additional requirements for PSL-2 and PSL-3 product are given in Annex H.



**10.15.11 Coupling stock, pup joints and accessories**

When NDE is required for coupling stock according to Table C.62 or Table E.62, the inspection shall be for the detection of longitudinal and transverse imperfections on the outside surface to acceptance level L2 by one or more of the following methods:

- ultrasonic testing in accordance with ISO 9303 or ASTM E213
- flux leakage testing in accordance with ISO 9402 or ASTM E570
- eddy current concentric coil testing in accordance with ISO 9304 or ASTM E309
- magnetic particle inspection in accordance with ISO 13665 or ASTM E709

Pup joints and accessories shall be inspected and meet the same requirements as casing and tubing.

- a) For pup joints and accessories made from full-length casing and tubing, the required inspection for inside and outside defects shall take place either before or after cutting into final length, provided there is no subsequent upsetting or heat treatment.
- b) For pup joints and accessories machined from pipe or bar stock, the required inspection shall take place either before or after machining to final product dimensions; however, the outside surface shall be visually inspected subsequent to being machined to final product dimensions.
- c) For all other pup joints and accessories, except for those round thread pup joints and accessories in d), the required inspection shall be performed according to a) above.
- d) For API round thread pup joints and accessories in size designations listed in Table C.3 or Table E.3 in Group 1, Group 2 Grades L80 and C95 and Group 3, the required inspections, unless otherwise agreed upon between purchaser and manufacturer, are as specified in e) and f).
- e) For outside surface and end areas, the required inspection shall be performed following any upset process and final heat treatment. For Group 3 pup joints and accessories, magnetic particle inspection for the detection of longitudinal and transverse defects may be substituted for the required outside surface inspection.
- f) For inside surface, the required inspection may take place before or after cutting to individual lengths, any upset process, or final heat treatment.
- g) The reference indicators used by the manufacturer to calibrate the compression and shear wave ultrasonic equipment may be retained in the coupling stock. If the reference indicators are retained in the reference standard, the OD surface area adjacent to the reference indicators shall be stencilled with the letters "RI". The reference indicators shall be considered defects and marked in accordance with 10.15.17 b).

Additional requirements for PSL-2 and PSL-3 product are given in Annex H.

**10.15.12 Untested pipe ends**

The end-area inspections shall be subsequent to all heat treatment.

It is emphasised that in many of the automatic NDE operations specified in this International Standard, there may be a short length at both pipe ends which cannot be tested. In such cases, the untested ends shall be either:

- a) cropped off, or
- b) subjected to magnetic particle inspection of the outside and inside surfaces around the full periphery and over the length of the untested ends, or

- c) subjected to a manual/semi-automatic test which achieves, as a minimum, the same degree of inspection as the automatic NDE.

Records in accordance with 10.15.4 shall be maintained.

Additional requirements for PSL-3 product are given in Annex H.

#### **10.15.13 Pipe upsets**

Forged upsets (including the upset run-out interval) on all grades, except Grades H40, J55 and K55, shall be subjected, after all heat-treatment operations, to NDE for the detection of transverse defects on the outside and inside surfaces of the upset, using the criteria given in 8.13. For all grades manufactured by the quench-and-temper process, the end-area inspection shall include inspection for longitudinal defects.

Records in accordance with 10.15.4 shall be maintained.

#### **10.15.14 Pipe, coupling stock and accessories requiring further evaluation**

In all cases, indications producing a threshold alarm condition as a result of the specified NDE operation(s) shall have the indications evaluated in accordance with 10.15.15, unless it can be demonstrated that the imperfection causing the indication is not a defect as described in 8.13.

#### **10.15.15 Evaluation of indications (prove-up)**

For an indication which is greater than or equal to the reject threshold, the manufacturer shall either evaluate it in accordance with this subclause or dispose of the indication as a defect in accordance with 10.15.16. Evaluation of indications shall be performed by NDE Level I certified inspectors under the supervision of NDE Level II or III certified inspectors, or by NDE Level II or III certified inspectors. Evaluation of indications shall be performed in accordance with documented procedures.

When no imperfection is found in the area of the original indication and there is no explanation for the indication, then the pipe shall be rejected or, at the manufacturer's option, re-inspected full-length either using the same inspection method or using ultrasonic inspection methods. At the manufacturer's option, the inspection equipment shall be adjusted either to the same sensitivity level as that used to perform the original inspection or to a reduced sensitivity that meets the specified requirements.

For the evaluation of an indicated imperfection, the depth shall be measured by one of the following methods:

- a) using a mechanical measuring device (for example, pit gauge, callipers, etc.). Removal of material by grinding or other means to facilitate measurement shall not, for pipe, reduce the remaining wall thickness below 87,5 % of the specified wall thickness or, for coupling stock, reduce the remaining outside diameter or wall thickness below the minimum specified on the purchase agreement. Abrupt changes in wall thickness caused by material removal during prove-up shall be removed.
- b) using an ultrasonic technique(s) (time- and/or amplitude-based), or other comparable techniques. Verification of the ultrasonic technique(s) shall be documented, and shall show capability to differentiate imperfection sizes larger and smaller than the appropriate defect size stated in 8.13.

If the purchaser and manufacturer do not agree on the evaluation test results, either party may require destructive evaluation of the material; after which disposition shall be as described in B.4.

Imperfections that have been evaluated and found to be defects shall be given a disposition in accordance with 10.15.16.

**10.15.16 Disposition of pipe containing defects**

Imperfections that satisfy the material requirements and are less than the defect size stated in 8.13 are allowed to remain in the pipe. Repair welding is not permitted. Pipe containing defects shall be given one of the following dispositions:

## a) grinding or machining

Grinding or machining of quench cracks is not permitted. Defects shall be completely removed by grinding or machining, provided the remaining wall thickness is within specified limits. Grinding or machining shall be carried out in such a way that the dressed area blends smoothly into the contour of the tube. Where the depth of the removal exceeds 10 % of the specified wall thickness, the remaining wall thickness shall be verified in accordance with 10.13.4. After removal of the defect, the affected area shall be re-inspected to verify that the defect was completely removed. The re-inspection shall be either

- 1) by the same inspection unit at the same sensitivity that performed the initial inspection, or
- 2) by another NDE method, or combination of methods, that demonstrate equal or greater sensitivity than the original NDE.

When method 2) above is used, the NDE method (or combination of methods) shall be documented and shall demonstrate equal or greater sensitivity than the original NDE. In addition, method 2) shall address the possibility that there may be other coincident defects in the affected area.

## b) cut-off

The section of pipe containing the defect shall be cut off within the limits of requirements on length of the intended product.

## c) rejection.

The pipe shall be rejected.

**10.15.17 Disposition of coupling stock containing defects**

Imperfections that satisfy the material requirements and are less than the defect size stated in 8.13 are allowed to remain in the coupling stock. Repair welding is not permitted. Coupling stock containing defects shall be given one of the following dispositions:

## a) grinding or machining

Defects shall be completely removed by grinding or machining, provided the remaining outside diameter is within specified limits. Grinding or machining shall be carried out in such a way that the dressed area blends smoothly into the contour of the tube. After removal of the defect, the outside diameter shall be measured in the dressed area for conformance to specification limits. The affected area shall also be re-inspected to verify that the defect was completely removed.

## b) marking the area of defect

If a defect is not removed from coupling stock within acceptable limits, then the area shall be marked to indicate the presence of a defect. The marking shall consist of a paint band encircling the tube body that covers the entire defect area if this area is equal to or less than 50 mm (2 in) in axial length, or bands in a cross-hatched pattern if this area is greater than 50 mm (2 in) in length. The band colour shall be agreed between the purchaser and manufacturer.

## c) cut off

The section of coupling stock containing the defect shall be cut off within the limits of requirements on length of the intended product.

d) rejection.

The coupling stock shall be rejected.

## 11 Marking

### 11.1 General

**11.1.1** Products manufactured in conformance with this International Standard shall be marked by the manufacturer as specified herein.

**11.1.2** For all manufacturers except threaders, the marking instructions in Clause 11, except those in 11.6, are applicable. For threaders, the marking instructions in 11.5 and 11.6 and Table C.68 or Table E.68 are applicable. Processors shall remove any identity that is not indicative of the new condition of the product as a result of heat treatment (for example, prior grade identity and original pipe manufacturer's name or logo).

**11.1.3** Products shall be colour-coded as specified in 11.4.

**11.1.4** Products shall be marked by stencilling, or a combination of stencilling and stamping, at the option of the manufacturer, as stipulated, with two exceptions:

- by agreement between purchaser and manufacturer, stamping can be required, in which case a combination of stamping and stencil marking shall be used;
- at the option of the manufacturer, hot-rolled or hot-stamped markings on pipe and couplings may be substituted for die-stamped markings and are permitted at intervals along the length.

**11.1.5** Requirements for optional stamp markings are specified in 11.2, and stencil markings shall be as specified in 11.3. Marking instructions and sequence of markings are specified in Table C.68 or Table E.68, which includes only those items that are stamped or stencilled for product identification. If die stamp marking is selected, it is not required to also stencil mark the information. Examples of markings are shown in Figure D.16. Marking shall not overlap and shall be applied in such a manner as not to injure the product.

**11.1.6** Additional markings for compatible standards shall be listed after "ISO 11960".

**11.1.7** In a circumstance where it is necessary to re-mark product with the original marking information, the accuracy and traceability of the transferred markings shall be the responsibility of the entity re-marking the product. The transferred markings shall include the words "transferred by « »", with the name of the entity responsible for transferring the markings shown between the « ».

**11.1.8** The date of manufacture is defined for marking purposes as either

- a) a two-digit number, consisting of the last digit of the year followed by the calendar quarter in which the markings of Clause 11 are completed, or
- b) a three-digit number, consisting of the last digit of the year followed by a two-digit number indicating the month in which the markings of Clause 11 are completed.

**11.1.9** Products manufactured in accordance with this third edition of ISO 11960 during the period of overlap of application (see Foreword) with the second edition shall be identified by using either "0" as the overlap period designation rather than the quarter, or "00" as the overlap period designation rather than the month. The overlap period designation "0" or "00" applies to the pipe body characteristics and does not apply to changes in API Spec 5B.

**11.1.10** Other additional markings are allowed and may be applied as desired by the manufacturer or as requested by the purchaser, but shall be applied after the markings specified in Table C.68 or Table E.68.

## 11.2 Stamp marking requirements

### 11.2.1 Methods

Permitted methods of stamp marking are as follows:

Number	Method
1	Hot-rolled or hot-stamped markings
2	Cold die stamping with standard dies
3	Cold die stamping with interrupted dot-face dies
4	Cold die stamping with rounded-face dies
5	Vibratory

After stamp marking, Group 2 and Group 4 products may require subsequent heat treatment as specified in 11.2.5. Such heat treatment shall be in accordance with 6.2. The sequence of stamp markings shall be as shown in Table C.68 or Table E.68.

### 11.2.2 Size

Sizes of stamp markings shall be as shown in Table C.65 or Table E.65.

### 11.2.3 Location

Placements of these markings on casing, liners and tubing sizes Label 1: 1.660 and larger shall be on the outside surface of each length within approximately 0,3 m (1 ft) from the coupling or box, either end of plain-end pipe or either end of pin-by-pin threaded pipe. The optional stamp marking on sizes smaller than Label 1: 1.660 may be on a metal tag affixed to each length or, for bundled tubing, stamped on a metal tag affixed to each bundle.

### 11.2.4 Groups 1 and 3

When specified on the purchase agreement, products shall be stamped by one or more of the methods in 11.2.1 at the option of the manufacturer.

### 11.2.5 Groups 2 and 4

When specified on the purchase agreement, products shall be stamped by one or more of the methods in 11.2.1 at the option of the manufacturer. In addition, the following apply:

- Group 2 (except Grades C90 and T95) shall be heat-treated subsequent to using method 2 in 11.2.1.
- Group 2 (Grades C90 and T95 only) and Group 4 products shall be heat-treated subsequent to using methods 2 and 4 in 11.2.1, with the following exceptions:
  - stamping of the make-up triangle;
  - when the stamp markings are removed by cropping or by grinding, machining, threading to a depth not less than twice the depth of the stamping;
  - by agreement between purchaser and manufacturer, the stamp marks may be left in the product.

### 11.2.6 Make-up triangle marking

For buttress casing in all sizes and grades and for round thread casing in sizes Label 1: 16 and larger in Grades H40, J55, K55 and M65, the make-up triangle shall be stamped on the outside of each length on both ends. By agreement between purchaser and manufacturer, the make-up triangle may be replaced with a transverse white paint band 10 mm (3/8 in) wide by 76 mm (3 in) long. To assist in locating the triangle or transverse white paint band on buttress casing, a 25 mm (1 in) wide by 610 mm (24 in) long longitudinal white paint stripe shall be placed adjacent to the triangle or transverse paint band on the field end; additionally, a 25 mm (1 in) wide by 100 mm (4 in) long longitudinal white paint stripe shall be placed adjacent to the triangle or transverse paint band on the mill end.

For Groups 1 and 3, the triangle shall be stamped by method 2 or 4 only.

For Group 2 (Grades C90 and T95 only), the triangle shall be stamped by method 3 only.

For Group 2 (except Grades C90 and T95) and Group 4, the triangle shall be stamped by method 3 or 4 only.

### 11.3 Stencil marking requirements

Stencil markings shall be placed on the outside surface of each length of pipe, beginning at least 0,6 m (2 ft) from the coupling or box or from either end of plain-end pipe, pin-by-pin threaded pipe or coupling stock. For accessories and pup joints less than 1,8 m (6 ft) in length, the required stencil markings may be placed on a decal attached to the outside surface within 0,3 m (1 ft) of the end. These markings shall be separated by a dash or shall be adequately spaced.

The sequence of stencil markings shall be as specified in Table C.68 or Table E.68, except the thread marking shall be at a location convenient to the manufacturer.

### 11.4 Colour identification

#### 11.4.1 Colour coding

Each product shall be colour-coded as specified in 11.4.2 to 11.4.6, unless otherwise specified on the purchase agreement.

#### 11.4.2 Product 1,8 m (6 ft) and longer

One or more of the following methods shall be used.

- a) For threaded pipe, pup joints and accessories: paint a band encircling the product at a distance not greater than 0,6 m (24 in) from the coupling or internally threaded end.
- b) For plain-end or pin-by-pin threaded product: paint a band encircling the product at a distance not greater than 0,6 m (24 in) from either end.
- c) Coupling: paint the entire outside surface of the coupling, including the appropriate coupling colour bands.
- d) If the pipe is furnished with special-clearance couplings or if the pipe and couplings are of a different grade (except Grades H40, J55 and K55 applied in accordance with 9.2.1), paint both the pipe and couplings as specified in items a), b) and c) above.

#### 11.4.3 Loose couplings

Paint the entire surface of the coupling, including the appropriate colour bands.

#### 11.4.4 Special-clearance couplings

Paint the coupling using the colours indicative of the steel grade from which the coupling is manufactured, and also paint a black band around the centre.

#### 11.4.5 Pup joints and accessories shorter than 1,8 m (6 ft) in length

Paint the entire surface except the threads, including the appropriate colour bands.

#### 11.4.6 Grade colour-codes

The colour and number of bands for each grade shall be as shown in Table C.66 or Table E.66.

### 11.5 Thread and end-finish marking — All groups

#### 11.5.1 API thread marking

For manufacturers, thread identification shall be stencilled on casing with round, buttress or extreme-line threads. For threaders, thread identification is required on casing and tubing. This thread identification shall be as shown in Table C.67 or Table E.67.

#### 11.5.2 Unfinished and special end-finish markings

Different marking is required for

- a) plain-end pipe furnished either upset or non-upset, or
- b) pipe with special end-finish not specified herein but having the body of the pipe manufactured in accordance with the requirements specified herein, or
- c) completed couplings and completed accessories furnished with special end-finish not specified herein but which meet all the other requirements specified herein for these products except dimensions.

This marking shall be as shown in Table C.68 or Table E.68.

### 11.6 Pipe-threader marking requirements — All groups

Pipe threaded by a facility other than the original pipe manufacturer shall be identified, by a stamp or stencil consistent with 11.1, 11.2 and 11.3 adjacent to the threads, with the name or mark of the threader, the specification mark, and size and type of thread as listed in 11.5 and Table C.67 or Table E.67.

The threader shall mark on the body of the pipe the actual hydrostatic test pressure, unless the pipe has been previously tested to the pressure required for the thread as shown in Tables C.45 to C.61 or Tables E.45 to E.61 and marked as specified in Table C.68 or Table E.68.

**EXAMPLE** For Label 1: 7, Label 2: 29.00, C95, long thread coupling:

**Case 1)** If the pipe manufacturer produced UF pipe and hydrostatic pressure-tested to 34,5 MPa (5 000 psi) based on the documented design basis of the tester for 177,8 mm (7 in) pipe (see 10.12.3), and marked P34,5 (P5000), then the threader shall pressure-test the pipe to 60,5 MPa (8 800 psi) and mark the pipe in accordance with Figure D.16.

**Case 2)** If the pipe manufacturer produced UF pipe and hydrostatic pressure-tested to 61,0 MPa (8 900 psi) and marked the pipe P61,0 (P8900), then the threader is not required to pressure-test the pipe or mark the test pressure.

The markings applied to the body of the pipe by the original pipe manufacturer shall not be removed or altered.

Use of the letters “API” to identify or certify that threads on tubular goods comply with API Spec 5B is not permitted.

## 12 Coating and protection

### 12.1 Coatings — All groups

#### 12.1.1 Coatings for protection during transit

Unless otherwise specified in the purchase agreement, pipe and couplings shall be given an external coating for protection from rust while in transit. An attempt should be made to make these coatings smooth, hard to the touch, and with minimum sags. The coating shall be rated to protect the pipe for at least three months. Unless otherwise specified on the purchase agreement, coupling stock shall be supplied without external coating (bare), except for a protective coating that may be applied over the stencil.

If bare pipe or specially coated pipe is desired, the purchase agreement should so state. For special coatings, the purchase agreement should state further whether the coating is to be applied to the full length or whether a certain specific distance from the end is to be left un-coated. Unless otherwise specified, such bare ends are commonly given a coating with oil for protection in transit.

NOTE 13 % Cr tubulars have shown a tendency toward localized pitting corrosion when stored in moist environments. Special precautions during coating, shipping and storage are worthwhile.

#### 12.1.2 Coatings for long-term storage

By agreement between purchaser and manufacturer, protective coatings, internal and external, may be required for pipe for long-term storage to protect against corrosion, especially when stored in a marine environment.

The following points shall apply.

- a) The protection shall be effective against corrosion in a marine environment during the long-term storage period defined by the purchaser and manufacturer; minor surface discolouration shall be acceptable.
- b) There shall be no need for removal of the protective coating before the running of the tubulars.
- c) Correct application of the coating is essential and the following parameters shall be assessed:
  - dryness of the pipe;
  - cleanliness of the pipe;
  - temperature at application;
  - thickness of the coating film.

## 12.2 Thread protectors

### 12.2.1 General

The entity performing the threading shall apply external and internal thread protectors of such design, material and mechanical strength to protect the thread and end of the pipe from damage under normal handling and transportation. External thread protectors shall cover the full length of the thread on the pipe, and internal thread protectors shall cover the equivalent total pipe thread length of the internal thread. Thread protectors shall be of such design and material to inhibit infiltration of dust and water to the threads during transportation and normal storage period. Normal storage period shall be considered as approximately one year. The thread forms in protectors shall be such that the product threads are not damaged by the protectors. Thread protectors are not required for pup joints and accessories provided they are packaged in a manner that protects the threads.



Additional requirements for PSL-2 and PSL-3 product are given in Annex H.

### **12.2.2 Material**

Protector material shall contain no compounds capable of causing corrosion or promoting adherence of the protectors to the threads and shall be suitable for service temperatures from  $-46\text{ }^{\circ}\text{C}$  to  $+66\text{ }^{\circ}\text{C}$  ( $-50\text{ }^{\circ}\text{F}$  to  $+150\text{ }^{\circ}\text{F}$ ).

### **12.2.3 Grade L80 Types 9Cr and 13Cr**

Bare steel thread protectors shall not be used on Grade L80 Types 9Cr and 13Cr tubulars.

### **12.2.4 Driftable thread protectors**

By agreement between purchaser and manufacturer, open-ended, driftable protectors may be supplied. Thread compound shall cover the entire thread and seal surfaces of the connection.

## **13 Documents**

### **13.1 Electronic media — All groups**

A material test report, certificate of compliance or similar document printed from or used in electronic form from an electronic data interchange (EDI) transmission shall be regarded as having the same validity as a counterpart printed in the certifier's facility. The content of the EDI-transmitted document shall meet the requirements of this International Standard and conform to any existing EDI agreement between purchaser and manufacturer.

### **13.2 Certification — Groups 1, 2 and 3**

A record of heat control tests shall be available to the purchaser.

The manufacturer shall, upon request by the purchaser, furnish to the purchaser a certificate of compliance stating that the material has been manufactured, sampled, tested and inspected in accordance with this International Standard and has been found to meet the requirements.

Additional requirements for PSL-2 and PSL-3 product are given in Annex H.

Where additional information is required, including the results of mechanical testing, the supplementary requirement in A.9 (SR15) shall be specified in the purchase agreement.

### **13.3 Certification requirements — Grade Q125**

A certification shall be provided by the manufacturer for all pipe shipped meeting Group 4 requirements. The requirements in A.9 (SR15) shall apply.

### **13.4 Retention of records**

Tests and inspections requiring retention of records in this International Standard are shown in Table C.69 or Table E.69. Such records shall be retained by the manufacturer and shall be available to the purchaser on request for a period of three years after the date of purchase from the manufacturer.

## 14 Minimum facility requirements for various categories of manufacturer

### 14.1 Pipe mill

A pipe mill shall operate one or more pipe-making facilities capable of producing products as described in Clause 6 of this International Standard. A pipe mill shall also have suitable equipment for, and be responsible for, weighing and marking pipe or coupling stock.

A pipe mill shall also have facilities for conducting all required tests and inspections. Alternatively, and at the option of the pipe mill, any of these tests or inspections may be provided by a subcontractor and may be located off-site. In the event that a subcontractor performs any of these services, the conduct of such inspections and tests shall be controlled and monitored by the pipe mill in accordance with a documented procedure.

### 14.2 Processor

A processor shall operate heat-treating facilities capable of heat-treating full lengths of pipe or coupling stock. A processor shall also have suitable equipment for, and be responsible for, weighing and marking pipe or coupling stock.

A processor shall also have facilities for conducting all required tests and inspections. Alternatively, and at the option of the processor, any of these tests or inspections may be provided by a subcontractor and may be located off site. In the event that a subcontractor performs any of these services, the conduct of such inspections and tests shall be controlled and monitored by the processor in accordance with a documented procedure.

### 14.3 Pipe threader

A pipe threader shall operate one or more threading machines capable of threading pipe ends to the dimensions and tolerances specified in API Spec 5B. A threader shall also have suitable equipment for, and be responsible for, markings. A threader shall also have access to master plug and ring gauges, as well as the required working gauges, for each size and type of thread.

A threader shall either have or have access to facilities for:

- a) applying couplings to specified make-up,
- b) hydrostatic testing the entire length to the pressure required for finished pipe,
- c) drift-testing the ends after threading and coupling in accordance with specification requirements, and
- d) measuring length.

In the event that a subcontractor performs any of items a), b), c) or d), such services shall be carried out in accordance with documented procedures and shall be controlled and monitored by the threader.

A threader (or a subcontractor) shall not change or alter the markings on the pipe body or certify that the pipe body complies with any ISO/API specification. When subcontract work is performed for the threader, it shall be the responsibility of the threader to ensure that such work complies with the requirements of this International Standard.

### 14.4 Coupling, pup-joint or accessory manufacturer

A coupling, pup-joint or accessory manufacturer shall operate equipment capable of machining and threading products in accordance with the dimensions and tolerances provided in the applicable specifications. The manufacturer shall also have access to master plug and ring gauges, as well as the required working gauges, for each size and type of thread produced on products marked by the manufacturer in accordance with Clause 11.

A coupling, pup-joint or accessory manufacturer shall have access to facilities for conducting all other aspects of the manufacturing process for the products (e.g. heat treatment). In the event that subcontractors perform these services, the conduct of inspections and tests shall be controlled and monitored by the coupling, pup-joint or accessory manufacturer in accordance with documented procedures.

Pup-joint manufacturers shall either have or have access to facilities for:

- a) hydrostatic testing and
- b) drift-testing finished products

in accordance with the requirements of this International Standard.

In the event that a subcontractor performs any of items a) or b), such services shall be carried out in accordance with documented procedures and shall be controlled and monitored by the manufacturer.

Coupling manufacturers shall be capable of inspecting couplings by the magnetic particle inspection or other adequate non-destructive testing method.

A manufacturer (or a subcontractor) shall not change or alter the markings on the pipe body or certify that the pipe body complies with any ISO/API specification. When subcontract work is performed for the manufacturer, it shall be the responsibility of the manufacturer to ensure that such work complies with the requirements of this International Standard.

## Annex A (normative)

### Supplementary requirements

#### A.1 General

This annex describes supplementary requirements that may be specified by the purchaser or agreed between purchaser and manufacturer. These requirements apply only when stated on the purchase agreement.

#### A.2 SR1 Supplementary non-destructive examination for Grades H40, J55, K55 and N80 Type 1

The specified casing and tubing shall be inspected for imperfections that are greater than 12,5 % of the specified wall thickness or which reduce the net effective wall thickness below 87,5 % of the specified wall thickness.

These imperfections shall be considered defects and shall be given a disposition in accordance with 10.15.16. The inspection(s), including forged upsets, shall be performed to minimum requirements stated in 10.15 for Grades N80Q, M65, L80 and C95.

#### A.3 SR2 Supplementary non-destructive examination for Grades H40, J55, K55, N80 Type 1, N80Q, M65, L80, C95 and P110 to A.10 (SR16)

The specified casing and tubing shall be inspected for imperfections that are greater than 5 % of the specified wall thickness or which reduce the net effective wall thickness below 87,5 % of the specified wall thickness. These imperfections shall be considered defects and shall be given a disposition in accordance with 10.15.16. The inspection(s), including forged upsets, shall be performed to the minimum requirements stated in 10.15 for Grade P110.

#### A.4 SR9 Coupling blanks — Grade Q125 only

##### A.4.1 SR9.1 Coupling blank size

Coupling blank dimensions shall be adequate to yield a fully machined cylinder with uniform wall thickness with an outside diameter, inside diameter and length as specified on the purchase agreement. The coupling blanks shall be provided fully machined by the manufacturer only when specified on the purchase agreement.

##### A.4.2 SR9.2 Dimensional tolerances

For fully machined coupling blanks, the tolerance on outside diameter shall be  ${}^{+2,38}_0$  mm ( ${}^{+3/32}_0$  in) and the tolerance on the inside diameter shall be  ${}^0_{-2,38}$  mm ( ${}^0_{-3/32}$  in), unless otherwise agreed upon between purchaser and manufacturer.

Coupling blanks ordered with as-rolled outside diameter surface shall have an outside diameter tolerance of  $\pm 1\%$ , but not greater than  $\begin{matrix} +3,18 \\ -1,59 \end{matrix}$  mm ( $\begin{matrix} +1/8 \\ -1/16 \end{matrix}$  in).

### **A.4.3 SR9.3 Imperfections**

Coupling blanks that will not be fully machined by either the manufacturer or the purchaser shall be inspected and meet the same requirements as finished couplings. Coupling blanks that will be fully machined by either the manufacturer or the purchaser may have imperfections on the as-rolled surface; however, the machined surface shall meet the surface inspection criteria of 9.14 and be to the specified dimensions.

### **A.4.4 SR9.4 Marking**

All coupling blanks meeting the requirements of A.4 (SR9) shall be marked as specified in Table C.68 or E.68 or Table C.81 or E.81.

## **A.5 SR10 Upset casing — Grade Q125 only**

### **A.5.1 SR10.1 Dimensions**

Grade Q125 casing shall be provided with upset end(s). Dimensions of the upset, if other than extreme-line (including tolerances), shall be specified on the purchase agreement.

### **A.5.2 SR10.2 Material properties**

Tensile, impact and hardness properties of the pipe and upset shall comply with the requirements of Clause 7. The allowable hardness variation of the upset shall be based on the nominal wall thickness of the upset specified on the purchase agreement. The tensile test specimens for the upset shall be the largest round specimen feasible. The size to be used shall be agreed by the purchaser and manufacturer prior to testing.

### **A.5.3 SR10.3 Heat treatment**

Upset pipe shall be heat-treated full length after upsetting.

### **A.5.4 SR10.4 Other testing considerations**

The frequency of testing, re-test provisions, identification, etc., for both the pipe body and the upset material shall be as specified in Clause 10.

### **A.5.5 SR10.5 End area inspection**

The outside and inside surfaces of the ends of upset pipe shall be inspected after final heat treatment and before threading for transverse and longitudinal defects by the magnetic particle method.

### **A.5.6 SR10.6 Machined surface inspection of extreme-line casing**

#### **A.5.6.1 SR10.6.1 Requirements for inspection**

The machined surface of extreme-line casing shall be visually examined for imperfections. The maximum permissible depth of imperfection measured from the surface shall be as specified in A.5.6.2 to A.5.6.4.

**A.5.6.2 SR10.6.2 Pin end**

Location of imperfection	Permissible depth
External surface:	12,5 % of specified pipe body wall thickness
Internal surface:	
From end of pipe to plane of external shoulder (bored):	0,38 mm (0.015 in)
From plane of external shoulder to upset run-out:	12,5 % of specified pipe body wall thickness

**A.5.6.3 SR10.6.3 Box end**

Location of imperfection	Permissible depth
External surface:	
From the end of the pipe to a plane 120,60 mm (4¾ in) from the end of pipe Label 1: 7-5/8 and smaller, and 165,10 mm (6½ in) from the end of pipe Label 1: 8-5/8 and larger:	0,25 mm (0.010 in)
From a plane 120,60 mm (4¾ in) from the end for pipe Label 1: 7-5/8 and smaller and 165,10 mm (6½ in) from the end for pipe Label 1: 8-5/8 and larger, to the upset run-out:	12,5 % of specified pipe body wall thickness
Internal surface:	12,5 % of specified pipe body wall thickness

**A.5.6.4 SR10.6.4**

All machined surfaces of the box shall be free of seams and cracks. All threads and seals shall be free of any imperfections which break the continuity.

**A.5.6.5 SR10.6.5**

The minimum wall thickness in the upset run-out interval, see Figure D.8, shall not be less than 87,5 % of the specified pipe body wall thickness.

**A.5.6.6 SR10.7 Dimensions and masses**

Dimensions and masses for extreme-line casing are shown in Tables C.24 and C.26 or Tables E.24 and E.26.

**A.6 SR11 Electric-welded casing, tubing and pup joints, Grade P110 and electric-welded casing and pup joints, Grade Q125****A.6.1 SR11.1 General**

Casing (Grades P110 and Q125) and tubing (Grade P110) may be produced by the electric-weld process only when detailed quality control provisions are jointly agreed by purchaser and manufacturer prior to the manufacture of the pipe. Tensile, impact and hardness testing shall be performed as frequently as required for seamless casing.

**A.6.2 SR11.2 Flattening test frequency****A.6.2.1 SR11.2.1 — Grade P110**

The flattening test frequency shall be as specified in 10.5.2.

**A.6.2.2 SR11.2.2 — Grade Q125**

Flattening tests shall be performed on each end of each length of pipe. On one end, flattening tests shall be made with weld at 6 o'clock and on the other end with weld at 3 o'clock. All inspection shall be performed and imperfections removed (cut-backs made) prior to removal of flattening test specimens.

**A.6.3 SR11.3 Flattening test procedures****A.6.3.1 SR11.3.1 — Grade P110**

The test specimens shall be flattened as specified in 10.5.3, 10.5.5 and 10.5.7.

**A.6.3.2 SR11.3.2 — Grade Q125**

Test specimens shall be rings or crop ends not less than 63,5 mm (2½ in) long, cut from each end of each length of pipe. Precautions shall be taken so that the test specimens can be identified with respect to the lengths of pipe from which they are cut. Flattening tests shall be conducted with the weld line located at the 6 o'clock or 3 o'clock position. Minimum acceptable flattening without cracking at any location shall be as shown in Table C.70 (SR11.1) or Table E.70 (SR11.1) or 0,85*D*, whichever requires the greater flattening.

No cracks or breaks shall occur anywhere in the specimen until the distance between the plates is less than that specified above; nor shall evidence of poor texture, incomplete fusion in the weld or laminations develop during the entire flattening process.

**A.6.4 SR11.4 Other material properties**

Electric-welded pipe shall meet the same tensile, impact and hardness requirements as seamless pipe. The impact test specimen shall be machined with the notch at the weld line. The requirements of Clause 10 (for seamless pipe) shall also apply to electric-welded pipe.

**A.6.5 SR11.5 Inspection and rejection****A.6.5.1 SR11.5.1 Non-weld area inspection**

The pipe body shall be inspected in the same manner as the seamless product as specified in Clause 10.

**A.6.5.2 SR11.5.2 Non-destructive examination of weld seam**

The weld seam of pipe (except upset ends) furnished to this International Standard shall be inspected non-destructively full length (100 %) by ultrasonic methods. The inspection shall be performed after all heat treatment and any subsequent rotary straightening operation. Pipe upsets shall be inspected as specified in 10.15.13.

**A.6.5.3 SR11.5.3 Equipment**

Any equipment utilizing the ultrasonic principles capable of continuous and uninterrupted inspection of the weld seam shall be used. The equipment shall be checked with an applicable reference standard as described in A.6.5.4 (SR11.5.4) at least once every working shift to demonstrate the effectiveness of the inspection equipment and procedures. The equipment shall be adjusted to produce well-defined indications when the reference standard is scanned by the inspection unit in a manner simulating the inspection of the product, and shall be capable of inspecting 1,6 mm (1/16 in) on either side of the weld line for the entire wall thickness.

**A.6.5.4 SR11.5.4 Reference standards**

A reference standard having the same specified diameter and thickness as the product being inspected shall be used to demonstrate the effectiveness of the inspection equipment and procedures at least once every working shift. The reference standard may be of any convenient length as determined by the manufacturer. It

shall be scanned by the inspection unit in a manner simulating the inspection of the product. For ultrasonic inspection, the reference standard shall contain two notches, one on the outer and one on the inner surface as specified in Figure D.17 (SR 11.1). The 1,6 mm (1/16 in) diameter hole shall be drilled radially through the wall of the reference standard. The inspection equipment shall be adjusted to produce a well-defined indication when the reference standard is scanned by the inspection unit.

#### **A.6.5.5 SR11.5.5 Rejection limits**

Any imperfection that produces a signal greater than or equal to the signal received from the reference standard shall be considered a defect unless it can be demonstrated by the manufacturer that the imperfection does not exceed the provisions of A.6.5.6 (SR11.5.6).

#### **A.6.5.6 SR11.5.6 Disposition**

Imperfections revealed by magnetic particle inspection and determined to be greater in depth than 5 % but not greater than 12,5 % of the specified wall thickness shall be removed by grinding or machining, or the pipe shall be rejected. All imperfections classified as defects by the ultrasonic or electromagnetic equipment which do not exceed 12,5 % of the specified wall thickness in depth shall be removed by grinding or machining, or the pipe shall be rejected.

Pipe with defects whose removal requires grinding or machining to a depth in excess of 12,5 % of the specified wall thickness shall be disposed of in accordance with 10.15.16. Where grinding or machining is done, generous radii shall be used to prevent abrupt changes in wall thickness, and such areas shall be re-inspected by one of the non-destructive inspection methods specified herein to verify complete removal of the defect.

### **A.7 SR12 Statistical impact testing**

#### **A.7.1 SR12.1 General**

This supplementary requirement specifies a statistical approach to testing. It is applicable only to those items that are accepted or rejected on a lot basis. The frequency of testing is based on standard statistical techniques for properties that have a normal distribution and where the standard deviation for a particular manufacturer, size, chemistry, etc., is not well established. The statistical acceptance and rejection procedures are required only for impact properties; however, the tensile and hardness properties shall be measured on all tubulars where impact samples are taken. Tensile, impact and hardness requirements are as required in Clause 7. The basis of the testing procedure is explained in Note 1 in A.7.5 (SR12.5).

#### **A.7.2 SR12.2 Frequency of testing**

Every length of casing shall be uniquely numbered. This number shall be used for all subsequent identification. Tensile, impact and hardness test specimens for casing shall be taken at the same frequency from locations shown in Figure D.10. The sample size for each lot of casing shall be selected by the manufacturer from Table C.71 (SR12.1) or Table E.71 (SR12.1).

The factor  $F$  shown for the sample size selected shall be used in A.7.4 (SR12.4) to determine acceptance or rejection of a lot based on the applicable transverse or longitudinal impact requirements. The number of samples is not dependent on the size of the lot. The lengths for testing shall be selected at random, provided the selection procedure provides samples representing at least the start and end of the heat treat cycle and both ends of the tubes (approximately 50 % each end).

By agreement between purchaser and manufacturer, a factor  $F$  of 3,090 may be used in lieu of the values given in Table C.71 (SR12.1) or Table E.71 (SR12.1) provided the standard deviation of the new lot of material is consistent with past experience.



### A.7.3 SR12.3 Re-test

If a tensile test specimen fails to conform to the specified requirements, the manufacturer shall make additional tests on each end of the tubular. If an impact test specimen fails to conform to the specified requirements, the manufacturer shall follow the re-test provisions of 10.7.7, 10.7.8 and 10.7.9 (as applicable). If a hardness test specimen fails to conform to the specified requirements, the manufacturer shall follow the re-test provisions of 10.6.10, 10.6.11, 10.6.12 and 10.6.13 (as applicable).

If any pipe is rejected from a lot due to failure to demonstrate acceptable tensile, impact or hardness requirements, then the pipe tempered immediately before and after the length rejected shall be tested on the same end as the pipe that was rejected. If one or both of the additional test lengths fail to conform to the specified requirements, the manufacturer may elect to test individually all remaining lengths in the lot, in which case determinations are required only for the particular requirement with which the specimens failed to comply in the preceding tests (i.e. a lot which meets the hardness and impact criteria but which has been rejected due to low elongation shall be re-tested to verify tensile properties). Specimens for all re-tests shall be taken in the same manner as the initial test specimen. Tubulars that fail to meet the requirements of Clause 7 shall be rejected.

### A.7.4 SR12.4 Acceptable impact energy for any lot of casing

Subsequent to impact testing, the mean and standard deviation shall be calculated for the average transverse impact energy values. This calculation shall be made including the data for all lengths rejected due to low impact energy. The lot minimum impact energy  $S_{\min}$  shall then be estimated (based on the sample data) as follows:

$$S_{\min} = \bar{S} - F \cdot \sigma_{\text{lot}}$$

where

$\bar{S}$  is the test lot mean impact energy;

$F$  is the factor determined from Table C.71 (SR12.1) or Table E.71 (SR12.1);

$\sigma_{\text{lot}}$  is the lot standard deviation.

### A.7.5 SR12.5 Lot acceptance/rejection

The lot shall be accepted provided  $S_{\min}$  is greater than or equal to  $C_V$  determined in 7.4, 7.5 or 7.6 (as applicable). If  $S_{\min}$  is less than  $C_V$ , then additional random joints may be selected for testing. The  $\bar{S}$ ,  $\sigma_{\text{lot}}$ , and  $S_{\min}$  shall be determined as above based on all the data and the new  $F$  value. The new  $S_{\min}$  shall exceed  $C_V$  determined in 7.4, 7.5 or 7.6, otherwise the lot shall be rejected. Additional random samples may be taken from additional pipes as many times as necessary. If the casing is rejected as a lot, then each length may be tested to demonstrate that it meets the minimum impact energy requirements of 7.4, 7.5 or 7.6 (as applicable).

NOTE 1 Explanation of testing frequency [see A.7.2 (SR12.2)]: Since a string of casing consists of more than one length of pipe, analysis should consider the probability that the string includes one or more lengths whose impact properties do not meet the desired minimum.

Table C.72 (SR12.2) or Table E.72 (SR12.2) gives the probability of a pipe string of 100 lengths including one or more unacceptable lengths. If the probability of any length being unacceptable is 1 in 1 000 then there is a 10 % chance that the pipe string will include one or more unacceptable lengths. If the probability of any length being unacceptable is 1 in 10 000, then there is a 1 % chance that the pipe string will include one or more unacceptable lengths. The statistical model used for the examination frequency is designed to yield an individual tube reliability of 99,9 %. A typical confidence limit of 95 % is used with a tolerance interval approach, since the standard deviation is neither well established nor expected to be consistent for all manufacturers, product sizes, heat treatments, chemistries, etc.

The tolerance interval approach assumes that the standard deviation is not well known. The factor  $F$  is large because it includes variations that can be expected in the standard deviation. For example, if the impact requirement is 27 J (20 ft-lb), 5 lengths are sampled and the standard deviation is determined to be 4,1 then the factor  $F$  is 7,501 (7.501). For the lot to

be acceptable, the average transverse impact value shall exceed  $27 + (7,501 \times 4,1)$  or 58 J [ $20 + (7.501 \times 3.0)$  or 43 ft-lb]. If 10 lengths had been sampled and the standard deviation was still 4,1, then the average impact value shall exceed  $27 + (5,203 \times 4,1)$  or 48 J [ $20 + (5.203 \times 3.0)$  or 36 ft-lb]. If the standard deviation from a mill is well known, then the factor  $F$  is taken for an infinite number of samples of  $F = 3,090$  (3.090). Assuming the standard deviation for an infinite number of samples from a given size tubular and one mill is 4,1, then the average impact value shall exceed  $27 + (3,090 \times 4,1)$  or 40 J [ $20 + (3.090 \times 3.0)$  or 29 ft-lb]. The method is applicable to both SI and USC units.

NOTE 2 The procedure in A.7 (SR 12) is taken from reference [5]. Table C.71 (SR12.1) or Table E.71 (SR12.1) is taken from Table A-7 in reference [5]. The procedure to calculate the mean and standard deviation for the average transverse impact energy for the lot can also be found in reference [5], Chapter 1, Clause 1-6.

## A.8 SR13 Seal-ring couplings

### A.8.1 SR13.1 Seal-ring groove

Seal-ring couplings shall be grooved in accordance with dimensions and tolerance specified in Figures D.18 (SR13.1) to D.21 (SR13.4). Grooves may be cut before or after threading at manufacturer's option. Grooves and threads shall be free of fins, wickers and ribbons that are loose or can become loose and fold into the thread form. Couplings shall be inspected after final machining of the groove. The inspection shall be by the wet fluorescent magnetic particle method, using a circumferentially oriented magnetic field, or by another non-destructive method of equal sensitivity as demonstrated to the purchaser. The inspection shall encompass both the inside and outside surfaces. The inspection shall exclude the dry magnetic particle method.

NOTE The seal-ring groove dimensions are not the same as those used historically and may not be interchangeable with them.

### A.8.2 SR13.2 Non-metallic ring

Dimensions and tolerances of non-metallic rings for seal-ring couplings shall be as specified in Figures D.18 (SR13.1) to D.21 (SR13.4). Rings shall be made from virgin polytetrafluoroethylene (PTFE) with 25 % fibreglass filler. The starting PTFE shall be free of filler.

Additional requirements for PSL-2 and PSL-3 product are given in Annex H.

NOTE The seal-ring dimensions are not the same as those used historically and may not be interchangeable with them.

### A.8.3 SR13.3 Marking

All couplings that meet the requirements of A.8 (SR13) shall be marked "S13".

## A.9 SR15 Test certificates

### A.9.1 SR15.1

The manufacturer shall provide the following data, as applicable, for each item for which this Supplementary Requirement is specified on the purchase agreement. The manufacturer's certificate shall cite this International Standard, and revision date thereof, to which the product was manufactured.

#### a) SR15.1.1

Specified diameter, wall thickness, grade, process of manufacture and type of heat treatment.

#### b) SR.15.1.2

The minimum tempering temperature allowed by the documented heat treatment procedure for each lot of quenched and tempered or normalized and tempered casing and tubing (except coupling stock).

## c) SR15.1.3

Chemical analyses (heat, product, control, and re-check) showing the mass fraction, expressed as a percent, of all elements whose limits or reporting requirements are set in this International Standard.

## d) SR15.1.4

Test data for all tensile tests required by this International Standard, including yield strength, ultimate tensile strength, elongation. The type, size and orientation of specimens shall be shown.

If elongation is recorded or reported, the record or report shall show the nominal width of the test specimen when strip specimens are used, the diameter and gauge length when round-bar specimens are used, or it shall state when full-section specimens are used.

## e) SR15.1.5

Impact test results [including the test criteria, and the size, location and orientation of the test specimen, the nominal test temperature (i.e. the actual test temperature, including the sub-size temperature reduction if applicable), the absorbed energy measured for each test specimen, the percent shear area, and the average absorbed energy for each test], where such testing is required by this International Standard.

## f) SR15.1.6

Hardness test results (including Rockwell hardness numbers and mean hardness numbers, test type and criterion, and specimen location and orientation) where such testing is required.

## g) SR15.1.7

The grain size and the test method used to determine the grain size.

## h) SR15.1.8

Minimum hydrostatic test pressure and duration.

## i) SR15.1.9

For welded pipe for which NDE of the weld seam is required by this International Standard, the method of NDE employed (ultrasonic, electromagnetic and/or magnetic particle) and the type of reference standard.

## j) SR15.1.10

For seamless product for which NDE is specified by the purchaser (either in the body of this International Standard, in the Supplementary Requirements, or in the purchase agreement), the method of inspection employed (ultrasonic, electromagnetic, or magnetic particle) and the type and size of the reference standard used.

## k) SR15.1.11

For electric-welded pipe, the minimum temperature for heat treatment of the weld seam. If such heat treatment is not performed, "No Seam Heat Treatment" shall be stated on the certificate.

## l) SR15.1.12

Results of any supplemental testing required by the purchaser.

## A.9.2 SR15.2

The manufacturer shall establish and follow procedures for maintaining heat and lot identity of all product covered by this Supplementary Requirement. The procedures shall provide means for tracing the product to the proper heat and lot, and to all applicable chemical and mechanical test results.

## A.10 SR 16 Impact testing (Charpy V-notch) for pipe

### A.10.1 SR16.1 Testing requirements

When A.10 (SR16) is specified on the purchase agreement for Group 1 Grade N80Q, Group 2 (except M65), and Group 3, the testing provisions of 10.7, which are optional for the manufacturer in accordance with 7.5.6, become mandatory. When A.10 (SR16) is specified on the purchase agreement for Group 1 Grades H40, J55, K55 and N80 Type 1, the requirements in A.10.2 are mandatory.

### A.10.2 SR16.2 Charpy V-notch test — General requirements

#### A.10.2.1 General

A test shall consist of three specimens from a pipe, taken from each lot in accordance with 10.2. The average result from the three impact specimens shall equal or exceed the absorbed energy requirement specified in A.10.3 (SR16.3). In addition, not more than one impact specimen shall exhibit an absorbed energy below the absorbed energy requirement, and in no case shall an individual impact specimen exhibit an absorbed energy below two-thirds of the absorbed energy requirement.

#### A.10.2.2 SR16.2.1 Specimen size

Table C.73 (SR16.1) or Table E.73 (SR16.1) provides the calculated wall thickness required to machine full-size,  $\frac{3}{4}$ -size, and  $\frac{1}{2}$ -size transverse impact test specimens. Table C.74 (SR16.2) or Table E.74 (SR16.2) provides the same information for longitudinal impact test specimens. The impact test specimen size that shall be selected from Table C.73 (SR16.1) or Table C.74 (SR16.2) or Table E.73 (SR16.1) or Table E.74 (SR16.2) is the largest impact test specimen having a calculated wall thickness that is less than the specified wall thickness for the pipe tested.

When the use of full-size (10 mm × 10 mm) transverse test specimens is not possible, the largest possible sub-size transverse test specimen listed in Table C.75 (SR16.3) or Table E.75 (SR16.3) shall be used. When it is not possible [or allowed in accordance with A.10.2.4 (SR16.2.4)] to test using any of these transverse test specimens, the largest possible longitudinal test specimen listed in Table C.75 (SR16.3) or Table E.75 (SR16.3) shall be used.

When the outside diameter or wall thickness precludes machining longitudinal impact test specimens  $\frac{1}{2}$ -size or larger, the pipe need not be tested; however, the manufacturer shall use a chemical composition and processing that is documented and demonstrated to result in impact energy absorption in excess of the minimum specified requirement.

#### A.10.2.3 SR16.2.2 Specimen allowance for outside diameter curvature

The surface of the finish-machined transverse test specimens may contain the outside diameter curvature of the original tubular product provided that the requirements of Figure D.22 (SR16.1) are met. These specimens shall be used only to permit the use of a transverse specimen of maximum thickness.

#### A.10.2.4 SR16.2.3 Hierarchy of test specimens

The hierarchy of test specimen orientation and size is as specified in Table C.76 (SR16.4) or Table E.76 (SR16.4).

**A.10.2.5 SR16.2.4 Alternative-size impact test specimens**

At the manufacturer's option, alternative-size impact test specimens, listed in Table C.75 (SR16.3) or Table E.75 (SR16.3), may be used in lieu of the minimum size specified in the tables referenced in A.10.2.1 (SR16.2.1). However, the alternative test specimen size shall be higher on the hierarchy table [Table C.76 (SR16.4) or Table E.76 (SR16.4)] than the specified size, and the absorbed energy requirement shall be adjusted consistent with the impact specimen orientation and size selected.

**A.10.2.6 SR16.2.5 Absorbed energy requirement for sub-size specimens**

The minimum CVN absorbed energy requirement,  $C_V$ , for sub-size test specimens shall be that specified for a full-size test specimen multiplied by the reduction factor in Table C.75 (SR16.3) or Table E.75 (SR16.3); however, in no event shall a sub-size test specimen be used if the reduced absorbed energy requirement is less than 11 J (8 ft-lb).

**A.10.3 SR16.3 Charpy V-notch test — Impact requirements for pipe and for externally threaded accessory material**

**A.10.3.1 SR16.3.1 Grade H40 only**

The minimum full-size transverse CVN absorbed energy requirement,  $C_V$ , is 16 J (12 ft-lb) for all wall thicknesses.

The minimum full-size longitudinal CVN absorbed energy requirement,  $C_V$ , is 20 J (15 ft-lb) for all wall thicknesses.

**A.10.3.2 SR16.3.2 Grades J55 and K55 only**

The minimum full-size transverse CVN absorbed energy requirement,  $C_V$ , is 20 J (15 ft-lb) for all wall thicknesses.

The minimum full-size longitudinal CVN absorbed energy requirement,  $C_V$ , is 27 J (20 ft-lb) for all wall thicknesses.

**A.10.3.3 SR16.3.3 Grade N80 Type 1**

The minimum CVN absorbed energy requirement for full-size test specimens for pipe is provided in Table C.77 (SR16.5) or Table C.78 (SR16.6), or Table E.77 (SR16.5) or Table E.78 (SR16.6).

The requirements are calculated based on the equations given below, where:

$Y_{S_{min}}$  is the minimum specified yield strength, in megapascals (552 MPa) [thousands of pounds per square inch (80 ksi)], and

$t$  is the specified wall thickness, in millimetres (inches).

Unit system	Transverse requirement $C_V$	Longitudinal requirement $C_V$
SI units, joules	$Y_{S_{min}} (0,001\ 18\ t + 0,012\ 59)$ or 14 J whichever is greater (Table C.77)	$Y_{S_{min}} (0,002\ 36\ t + 0,025\ 18)$ or 27 J whichever is greater (Table C.78)
USC units, foot pounds	$Y_{S_{min}} (0.152\ t + 0.064)$ or 10 ft-lb whichever is greater (Table E.77)	$Y_{S_{min}} (0.304\ t + 0.128)$ or 20 ft-lb whichever is greater (Table E.78)

#### **A.10.4 SR16.4 Accessories with integral joint API tubing connections and extreme line casing connections**

The requirements in 7.4 shall apply. The critical thickness shall be as specified in 7.3.2 and 7.6.6.

#### **A.10.5 SR16.5 Accessories with internal special end-finish connections that do not have thread interference**

The requirements in A.10.3 (SR16.3) apply. The critical thickness shall be as specified in 7.3.2 and 7.6.6.

#### **A.10.6 SR16.6 Impact test procedures**

##### **A.10.6.1 SR16.6.1 General procedures**

CVN Type A impact tests shall be conducted as specified in ASTM A370 and ASTM E23. When transverse impact test specimens are used for EW pipe, the test specimen shall be machined with the notch at the weld line. When longitudinal impact test specimens are used for EW pipe, the test specimens shall be taken from a location approximately 90° from the weld. Impact test specimens shall not be machined from flattened tubulars.

##### **A.10.6.2 SR16.6.2 Specimen orientation**

Specimen orientation shall be in accordance with Figure D.12.

##### **A.10.6.3 SR16.6.3 Test temperature**

The test temperature for full-size test specimens shall be specified by the purchaser as:

- a) + 21 °C (+ 70 °F), or
- b) 0 °C (+ 32 °F), or
- c) – 10 °C (+ 14 °F), or
- d) other temperature as specified on the purchase agreement.

The tolerance on the test temperature for full-size test specimens shall be  $\pm 3$  °C ( $\pm 5$  °F).

The test temperature shall be reduced as specified in A.10.6.5 (SR16.5.5) for Grades H40, J55 and K55 when sub-size test specimens are required.

Additional requirements for PSL-2 and PSL-3 product are given in Annex H.

**NOTE** The Grades H40, J55 and K55 are low strength steels considered to be loading-rate sensitive. Increasing the loading rate from that generally occurring in the use of the product to the loading rate occurring in the impact testing of the Charpy specimens results in shifting the fracture transition to higher temperatures. Thus, the fracture transition behaviour of the product would be expected to occur at temperatures lower than those obtained with Charpy testing. In most applications, testing Grades H40, J55 and K55 at + 21 °C (+ 70 °F) and higher strength grades at 0 °C (+ 32 °F) should be adequate. If the pipe will be handled at temperatures below – 18 °C (0 °F), a lower impact test temperature may be appropriate.

##### **A.10.6.4 SR16.6.4 Defective specimens**

Any test specimen that shows defective preparation or material imperfections unrelated to the intent of the test, whether observed before or after testing, may be discarded and be replaced by another specimen from the same length of pipe. Specimens shall not be judged defective simply because they failed to exhibit the minimum absorbed energy requirement.

**A.10.6.5 SR16.6.5 Sub-size test temperature reduction — Grades H40, J55 and K55 only**

A test temperature reduction may be required when sub-size test specimens are used. The test temperature reduction depends on the thickness of the pipe and the size of the impact test specimen.

The test temperature reduction specified in Table C.79 (SR16.7) or Table E.79 (SR 16.7) shall be used when applicable.

**A.10.6.6 SR16.6.6 Frequency of testing**

One test shall be made on one pipe from each lot.

**A.10.6.7 SR16.6.7 Reject of a pipe or accessory**

If the results from more than one specimen are below the specified minimum absorbed energy requirement or if one value is below two-thirds of the specified minimum absorbed energy requirement, a re-test shall be carried out on three additional specimens from the same pipe. The impact energy of each of the re-test specimens shall equal or exceed the specified minimum absorbed energy requirement or the pipe shall be rejected.

**A.10.6.8 SR16.6.8 Replacement of a reject pipe or accessory**

If the results of a test do not meet the requirements of A.10.3 (SR16.3), A.10.4 (SR16.4) or A.10.5 (SR16.5) as applicable and do not qualify for re-testing accordance with A.10.6.7 (SR16.6.7), then an additional three test specimens shall be removed from each of three additional pipes from the lot. If all the additional pipes tested conform to the requirements, then the lot shall be qualified except for the pipe that was initially rejected. If one or more of the additional test pipes fail to conform to the specified requirements, the manufacturer may elect to test individually the remaining pipe in the lot or re-heat-treat and test the lot as a new lot.

**A.10.6.9 SR16.6.9 Rounding procedures**

For purposes of determining conformance with these requirements, an observed value shall be rounded to the nearest whole number in accordance with the rounding method of ISO 31-0 or ASTM E29. Further, limiting values as specified or calculated shall be expressed as whole numbers, rounded if necessary.

**A.10.7 SR16.7 Reporting**

The size and orientation of the test specimen (i.e. full-size,  $\frac{3}{4}$ -size or  $\frac{1}{2}$ -size), the actual test temperature (i.e. specified temperature less the test temperature reduction that may be applicable for Grades H40, J55, and K55), the results of the individual specimens (i.e. the impact energy absorption and the percentage shear), and the average absorbed energy shall be reported to the purchaser.

**A.10.8 SR16.8 Marking**

Pipe tested in accordance with this supplementary requirement shall be marked to indicate A.10 (SR16), the minimum full-size energy absorption requirement, and the specified test temperature (i.e. not including the test temperature reduction that may be applicable for Grades H40, J55 and K55) preceded by a positive or negative sign. This marking shall be paint-stencilled after the grade designation.

Example for SI units:           S16-20-10C

Example for USC units:       S16-15+14F

## A.11 SR22 Enhanced leak resistance LTC

### A.11.1 General

By agreement between purchaser and manufacturer, the Supplementary Requirements for enhanced leak resistance LTC in SR22 shall apply. It should be noted that the SR22 product is fully interchangeable with standard API LTC connections. However, the SR22 design criteria concerning leak resistance shall not apply for such mixed product.

Liquid metal embrittlement may result if thread compound containing lead is used with tin-plated couplings at elevated temperatures for some materials. Use of thread compounds containing lead in applications involving temperatures in excess of 135 °C (275 °F) is cautioned.

NOTE The application of API connections or pipe at elevated temperature or in sour service conditions is beyond the scope of this International Standard.

### A.11.2 SR22 Enhanced leak resistance

#### A.11.2.1 SR22.1

Casings and couplings shall be furnished with enhanced leak resistance LTC connections in accordance with the requirements specified in API Spec 5B SR22 for dimensions, inspection and coupling thread coatings.

#### A.11.2.2 SR22.2.a Die stamp-marking the end of the pipe

An equilateral triangle die stamp 6,35 mm ( $\frac{1}{4}$  in) high shall be placed at a distance of  $L_g$  from each end of each pipe using Method 3, 4 or 5 of 11.2.1. See Figure D.24 SR22-1.

#### A.11.2.3 SR22.2.b Paint-marking the end of the pipe

High-visibility green paint marks shall be applied on the field end of each pipe. See Figure D.24 SR22-1.

#### A.11.2.4 SR22.2.c Die stamp-marking the couplings

All couplings shall be marked "S22" using Method 3 or 5 of 11.2.1.

#### A.11.2.5 SR22.2.d Colour-banding the couplings

Couplings shall be colour-banded with the colour(s) indicative of the steel grade from which the couplings are manufactured, and shall also be painted with a high-visibility green band around the outside surface near one end of the coupling.

#### A.11.2.6 SR22.3 Optional tapered bore requirement for casing with special drift requirements

For casing ordered with a drift mandrel of diameter larger than standard (see 8.10), the manufacturer may drift or bore along the inside diameter of the ends of the pipe. This option requires either of the following treatments for both ends of the pipe:

- a) to be drifted with a special end drift with a minimum diameter in accordance with the "special end drift diameter" column of Option 1 in Figure D.25 (SR22.2). The drift shall be inserted a distance equal to or greater than  $L_g$ . Pipe ends that are too small to accept the special end drift shall be bored along the inside diameter in accordance with b) below.
- b) to be finished with a tapered bore along the inside diameter with a taper between 2° and 15°, the maximum diameter of the machined surface at the end of the pipe "(chamfer diameter  $d_0$ )", and the angle of the tapered bore shall be in accordance with Option 2 in Figure D.25 SR22-2. The tapered bore machined surface need not run continuously around the inside circumference. The bore shall run



smoothly to the pipe inside diameter. If bored, the inside diameter of every pin end shall meet the requirements of Option 2 “ $d_0$ ”.

#### **A.11.2.7 SR22.4.1 Application of thread compound**

ISO 13678 thread compound shall be applied in one of the three following locations:

- to the pin end only;
- to the coupling thread only;
- to the pin in a band approximately 25 mm (1 in) wide at the large end of the thread and to the entire coupling thread.

In all cases, the full thread-form outline shall be clearly discernible after applying thread compound evenly over the surface.

It should be recognised by the user that compliance with ISO 13678 does not ensure adequate thread compound system performance in field service. The user has the responsibility of evaluating the results obtained from the procedures and test protocols and determining if the thread compound system in question meets the anticipated requirements of that particular field service application.

NOTE For the purposes of this provision, API RP 5A3 is equivalent to ISO 13678.

#### **A.11.2.8 SR22.4.2 Coupling make-up**

SR22 requires make-up based on power turns and position, not torque. Torque is not a basis for acceptance or rejection, but is an indicator of process control. Make-up shall be rejected when the coupling does not achieve the position criteria with minimum power-turns.

#### **A.11.2.9 SR22.4.3 Coupling make-up speed**

Power make-up speed shall not exceed 10 r/min.

#### **A.11.2.10 SR22.4.4 Coupling make-up acceptance criteria**

Options are allowed for SR22 connection make-up. Make-up shall be rejected when the coupling does not make the position criteria with minimum power-turns. Any connection in which the face of the coupling advances beyond the apex of the triangle shall be rejected. The coupling make-up shall be verified by one of the following methods:

- a) by power turns: the number of power turns shall equal or exceed the minimum number of power turns specified in Table C.80 or Table E.80 SR22-1. Counting power turns should start at a reference start torque specified in Table C.80 or Table E.80 SR22-1. Ensure proper alignment in make-up equipment and identity, and minimize abnormal sources of torque oscillation;
- b) by position: make up the face of the coupling within the triangle mark. Verify that the number of power turns equals or exceeds the number of power turns specified in Table C.80 or Table E.80 SR22-1 during operations.

#### **A.11.2.11 SR22.4.5 Coupling break-out and make-up**

If a connection is broken out, subsequent make-up shall be in accordance with A.11.2.10 (SR22.4.4).

## **Annex B** (normative)

### **Purchaser inspection**

#### **B.1 Inspection notice**

If the inspector representing the purchaser desires to inspect the pipe or witness a test, reasonable notice shall be given of the time at which the run is to be made.

#### **B.2 Plant access**

The inspector representing the purchaser shall have unrestricted access, at all times while work on the contract of the purchaser is being performed, to all parts of the manufacturer's works which will concern the manufacturer of the pipe or couplings ordered. The manufacturer shall afford the inspector all reasonable facilities to satisfy the inspector that the pipe is being manufactured in accordance with this International Standard. All inspections should be made prior to shipment at the place of manufacture or processing, unless otherwise specified on the purchase agreement, and shall be so conducted as not to interfere unnecessarily with the operation of the works.

#### **B.3 Compliance**

The manufacturer is responsible for complying with all of the provisions of this International Standard. The purchaser may make any investigation necessary to ensure compliance by the manufacturer and may reject any material that does not comply with this International Standard.

#### **B.4 Rejection**

Unless otherwise provided, material which shows defects on inspection or subsequent to acceptance at manufacturer's works, or which proves defective when properly applied in service, may be rejected, and the manufacturer so notified. If tests that require the destruction of material are made, any product which is proven not to meet the requirements of this International Standard shall be rejected. Disposition of rejected product shall be a matter of agreement between purchaser and manufacturer.

## Annex C (normative)

### Tables in SI units

**Table C.1 — ISO/API casing list**  
**Sizes, masses, wall thickness, grade and applicable end-finish**

Labels <sup>a</sup>		Outside diameter <i>D</i> mm	Nominal linear mass <sup>b, c</sup> T&C kg/m	Wall thickness <i>t</i> mm	Type of end-finish							
					H40	J55 K55	M65	L80 C95	N80 Type 1,Q	C90 T95	P110	Q125
1	2	3	4	5	6	7	8	9	10	11	12	13
4-1/2	9.50	114,30	14,14	5,21	PS	PS	PS	—	—	—	—	—
4-1/2	10.50	114,30	15,63	5,69	—	PSB	PSB	—	—	—	—	—
4-1/2	11.60	114,30	17,26	6,35	—	PSLB	PLB	PLB	PLB	PLB	PLB	—
4-1/2	13.50	114,30	20,09	7,37	—	—	PLB	PLB	PLB	PLB	PLB	—
4-1/2	15.10	114,30	22,47	8,56	—	—	—	—	—	—	PLB	PLB
5	11.50	127,00	17,11	5,59	—	PS	PS	—	—	—	—	—
5	13.00	127,00	19,35	6,43	—	PSLB	PSLB	—	—	—	—	—
5	15.00	127,00	22,32	7,52	—	PSLBE	PLB	PLBE	PLBE	PLBE	PLBE	—
5	18.00	127,00	26,79	9,19	—	—	PLB	PLBE	PLBE	PLBE	PLBE	PLBE
5	21.40	127,00	31,85	11,10	—	—	PLB	PLB	PLB	PLB	PLB	PLB
5	23.20	127,00	34,53	12,14	—	—	—	PLB	PLB	PLB	PLB	PLB
5	24.10	127,00	35,86	12,70	—	—	—	PLB	PLB	PLB	PLB	PLB
5-1/2	14.00	139,70	20,83	6,20	PS	PS	PS	—	—	—	—	—
5-1/2	15.50	139,70	23,07	6,98	—	PSLBE	PSLB	—	—	—	—	—
5-1/2	17.00	139,70	25,30	7,72	—	PSLBE	PLB	PLBE	PLBE	PLBE	PLBE	—
5-1/2	20.00	139,70	29,76	9,17	—	—	PLB	PLBE	PLBE	PLBE	PLBE	—
5-1/2	23.00	139,70	34,23	10,54	—	—	PLB	PLBE	PLBE	PLBE	PLBE	—
5-1/2	26.80	139,70	39,88	12,70	—	—	—	—	—	P	—	PLBE
5-1/2	29.70	139,70	44,20	14,27	—	—	—	—	—	P	—	—
5-1/2	32.60	139,70	48,51	15,88	—	—	—	—	—	P	—	—
5-1/2	35.30	139,70	52,53	17,45	—	—	—	—	—	P	—	—
5-1/2	38.00	139,70	56,55	19,05	—	—	—	—	—	P	—	—
5-1/2	40.50	139,70	60,27	20,62	—	—	—	—	—	P	—	—
5-1/2	43.10	139,70	64,14	22,22	—	—	—	—	—	P	—	—
6-5/8	20.00	168,28	29,76	7,32	PS	PSLB	PSLB	—	—	—	—	—
6-5/8	24.00	168,28	35,72	8,94	—	PSLBE	PLB	PLBE	PLBE	PLBE	PLBE	—
6-5/8	28.00	168,28	41,67	10,59	—	—	PLB	PLBE	PLBE	PLBE	PLBE	—
6-5/8	32.00	168,28	47,62	12,06	—	—	—	PLBE	PLBE	PLBE	PLBE	PLBE
7	17.00	177,80	25,30	5,87	PS	—	—	—	—	—	—	—
7	20.00	177,80	29,76	6,91	PS	PS	PS	—	—	—	—	—
7	23.00	177,80	34,23	8,05	—	PSLBE	PLB	PLBE	PLBE	PLBE	—	—
7	26.00	177,80	38,69	9,19	—	PSLBE	PLB	PLBE	PLBE	PLBE	PLBE	—
7	29.00	177,80	43,16	10,36	—	—	PLB	PLBE	PLBE	PLBE	PLBE	—
7	32.00	177,80	47,62	11,51	—	—	PLB	PLBE	PLBE	PLBE	PLBE	—
7	35.00	177,80	52,09	12,65	—	—	—	PLBE	PLBE	PLBE	PLBE	PLBE
7	38.00	177,80	56,55	13,72	—	—	—	PLBE	PLBE	PLBE	PLBE	PLBE
7	42.70	177,80	63,54	15,88	—	—	—	—	—	P	—	—
7	46.40	177,80	69,05	17,45	—	—	—	—	—	P	—	—
7	50.10	177,80	74,56	19,05	—	—	—	—	—	P	—	—
7	53.60	177,80	79,77	20,62	—	—	—	—	—	P	—	—
7	57.10	177,80	84,97	22,22	—	—	—	—	—	P	—	—

See notes at end of table.

Table C.1 (continued)

Labels <sup>a</sup>		Outside diameter <i>D</i> mm	Nominal linear mass <sup>b, c</sup> T&C kg/m	Wall thickness <i>t</i> mm	Type of end-finish							
1	2				H40	J55 K55	M65	L80 C95	N80 Type 1,Q	C90 T95	P110	Q125
1	2	3	4	5	6	7	8	9	10	11	12	13
7-5/8	24.00	193,68	35,72	7,62	PS	—	—	—	—	—	—	—
7-5/8	26.40	193,68	39,29	8,33	—	PSLBE	PSLB	PLBE	PLBE	PLBE	—	—
7-5/8	29.70	193,68	44,20	9,52	—	—	PLB	PLBE	PLBE	PLBE	PLBE	—
7-5/8	33.70	193,68	50,15	10,92	—	—	PLB	PLBE	PLBE	PLBE	PLBE	—
7-5/8	39.00	193,68	58,04	12,70	—	—	—	PLBE	PLBE	PLBE	PLBE	PLBE
7-5/8	42.80	193,68	63,69	14,27	—	—	—	PLB	PLB	PLB	PLB	PLB
7-5/8	45.30	193,68	67,41	15,11	—	—	—	PLB	PLB	PLB	PLB	PLB
7-5/8	47.10	193,68	70,09	15,88	—	—	—	PLB	PLB	PLB	PLB	PLB
7-5/8	51.20	193,68	76,19	17,45	—	—	—	—	—	P	—	—
7-5/8	55.30	193,68	82,30	19,05	—	—	—	—	—	P	—	—
7-3/4	46.10	196,85	68,60	15,11	—	—	—	P	P	P	P	P
8-5/8	24.00	219,08	35,72	6,71	—	PS	PS	—	—	—	—	—
8-5/8	28.00	219,08	41,67	7,72	PS	—	PS	—	—	—	—	—
8-5/8	32.00	219,08	47,62	8,94	PS	PSLBE	PSLB	—	—	—	—	—
8-5/8	36.00	219,08	53,57	10,16	—	PSLBE	PSLB	PLBE	PLBE	PLBE	—	—
8-5/8	40.00	219,08	59,53	11,43	—	—	PLB	PLBE	PLBE	PLBE	PLBE	—
8-5/8	44.00	219,08	65,48	12,70	—	—	—	PLBE	PLBE	PLBE	PLBE	—
8-5/8	49.00	219,08	72,92	14,15	—	—	—	PLBE	PLBE	PLBE	PLBE	PLBE
9-5/8	32.30	244,48	48,07	7,92	PS	—	—	—	—	—	—	—
9-5/8	36.00	244,48	53,57	8,94	PS	PSLB	PSLB	—	—	—	—	—
9-5/8	40.00	244,48	59,53	10,03	—	PSLBE	PSLB	PLBE	PLBE	PLBE	—	—
9-5/8	43.50	244,48	64,73	11,05	—	—	PLB	PLBE	PLBE	PLBE	PLBE	—
9-5/8	47.00	244,48	69,94	11,99	—	—	PLB	PLBE	PLBE	PLBE	PLBE	PLBE
9-5/8	53.50	244,48	79,62	13,84	—	—	—	PLBE	PLBE	PLBE	PLBE	PLBE
9-5/8	58.40	244,48	86,91	15,11	—	—	—	PLB	PLB	PLB	PLB	PLB
9-5/8	59.40	244,48	88,40	15,47	—	—	—	—	—	P	—	—
9-5/8	64.90	244,48	96,58	17,07	—	—	—	—	—	P	—	—
9-5/8	70.30	244,48	104,62	18,64	—	—	—	—	—	P	—	—
9-5/8	75.60	244,48	112,50	20,24	—	—	—	—	—	P	—	—
10-3/4	32.75	273,05	48,74	7,09	PS	—	—	—	—	—	—	—
10-3/4	40.50	273,05	60,27	8,89	PS	PSB	PSB	—	—	—	—	—
10-3/4	45.50	273,05	67,71	10,16	—	PSBE	PSB	—	—	—	—	—
10-3/4	51.00	273,05	75,90	11,43	—	PSBE	PSB	PSBE	PSBE	PSBE	PSBE	—
10-3/4	55.50	273,05	82,59	12,57	—	—	PSB	PSBE	PSBE	PSBE	PSBE	—
10-3/4	60.70	273,05	90,33	13,84	—	—	—	—	—	PSBE	PSBE	PSBE
10-3/4	65.70	273,05	97,77	15,11	—	—	—	—	—	PSB	PSB	PSB
10-3/4	73.20	273,05	108,93	17,07	—	—	—	—	—	P	—	—
10-3/4	79.20	273,05	117,86	18,64	—	—	—	—	—	P	—	—
10-3/4	85.30	273,05	126,94	20,24	—	—	—	—	—	P	—	—
11-3/4	42.00	298,45	62,50	8,46	PS	—	—	—	—	—	—	—
11-3/4	47.00	298,45	69,94	9,53	—	PSB	PSB	—	—	—	—	—
11-3/4	54.00	298,45	80,36	11,05	—	PSB	PSB	—	—	—	—	—
11-3/4	60.00	298,45	89,29	12,42	—	PSB	PSB	PSB	PSB	PSB	PSB	PSB
11-3/4	65.00	298,45	96,73	13,56	—	—	—	P	P	P	P	P
11-3/4	71.00	298,45	105,66	14,78	—	—	—	P	P	P	P	P
13-3/8	48.00	339,72	71,43	8,38	PS	—	—	—	—	—	—	—
13-3/8	54.50	339,72	81,10	9,65	—	PSB	PSB	—	—	—	—	—
13-3/8	61.00	339,72	90,78	10,92	—	PSB	PSB	—	—	—	—	—
13-3/8	68.00	339,72	101,19	12,19	—	PSB	PSB	PSB	PSB	PSB	PSB	—
13-3/8	72.00	339,72	107,15	13,06	—	—	—	PSB	PSB	PSB	PSB	PSB

See notes at end of table.

**Table C.1 (continued)**

Labels <sup>a</sup>		Outside diameter	Nominal linear mass <sup>b, c</sup> T&C	Wall thickness	Type of end-finish							
					H40	J55 K55	M65	L80 C95	N80 Type 1,Q	C90 T95	P110	Q125
1	2	D mm	kg/m	t mm	6	7	8	9	10	11	12	13
1	2	3	4	5	6	7	8	9	10	11	12	13
16	65.00	406,40	96,73	9,53	PS	—	—	—	—	—	—	—
16	75.00	406,40	111,61	11,13	—	PSB	PSB	—	—	—	—	—
16	84.00	406,40	125,01	12,57	—	PSB	PSB	—	—	—	—	—
16	109.00	406,40	162,21	16,66	—	P	—	P	P	—	P	P
18-5/8	87.50	473,08	130,21	11,05	PS	PSB	PSB	—	—	—	—	—
20	94.00	508,00	139,89	11,13	PSL	PSLB	PSLB	—	—	—	—	—
20	106.50	508,00	158,49	12,70	—	PSLB	PSLB	—	—	—	—	—
20	133.00	508,00	197,93	16,13	—	PSLB	—	—	—	—	—	—

P = Plain end, S = Short round thread, L = Long round thread, B = Buttress thread, E = Extreme-line.

<sup>a</sup> Labels are for information and assistance in ordering.

<sup>b</sup> Nominal linear masses, threaded and coupled (col. 2) are shown for information only.

<sup>c</sup> The densities of martensitic chromium steels (L80 types 9Cr and 13Cr) are different from carbon steels. The masses shown are therefore not accurate for martensitic chromium steels. A mass correction factor of 0,989 may be used.

**Table C.2 — ISO/API plain-end casing liner list — Grade J55**

Labels		Outside diameter	Plain-end linear mass	Wall thickness
1	2	D mm	kg/m	t mm
1	2	3	4	5
3-1/2	9.92	88,90	14,76	7,34
4	11.35	101,60	16,89	7,26
4-1/2	13.05	114,30	19,42	7,37
5	17.95	127,00	26,71	9,19
5-1/2	19.83	139,70	29,51	9,17
6-5/8	27.66	168,28	41,18	10,59

**Table C.3 — ISO/API tubing list**  
**Sizes, masses, wall thickness, grade and applicable end-finish**

Labels				Outside diameter	Nominal linear masses <sup>a, b</sup>			Wall thickness	Type of end finish <sup>c</sup>						
1	2				D mm	Non-upset T&C kg/m	Ext. upset T&C kg/m		Integ. joint kg/m	t mm	H40	J55	L80	N80 Type 1,Q	C90
	NU T&C	EU T&C	IJ	10				11							
1	2	3	4	5	6	7	8	9	10	11	12	13	14	15	16
1.050	1.14	1.20	—	26,67	1,70	1,79	—	2,87	PNU	PNU	PNU	PNU	PNU	PNU	—
1.050	1.48	1.54	—	26,67	2,20	2,29	—	3,91	PU	PU	PU	PU	PU	PU	PU
1.315	1.70	1.80	1.72	33,40	2,53	2,68	2,56	3,38	PNU	PNU	PNU	PNU	PNU	PNU	—
1.315	2.19	2.24	—	33,40	3,26	3,33	—	4,55	PU	PU	PU	PU	PU	PU	PU
1.660	2.09	—	2.10	42,16	—	—	3,13	3,18	PI	PI	—	—	—	—	—
1.660	2.30	2.40	2.33	42,16	3,42	3,57	3,47	3,56	PNU	PNU	PNU	PNU	PNU	PNU	—
1.660	3.03	3.07	—	42,16	4,51	4,57	—	4,85	PU	PU	PU	PU	PU	PU	PU
1.900	2.40	—	2.40	48,26	—	—	3,57	3,18	PI	PI	—	—	—	—	—
1.900	2.75	2.90	2.76	48,26	4,09	4,32	4,11	3,68	PNU	PNU	PNU	PNU	PNU	PNU	—
1.900	3.65	3.73	—	48,26	5,43	5,55	—	5,08	PU	PU	PU	PU	PU	PU	PU
1.900	4.42	—	—	48,26	6,58	—	—	6,35	—	—	P	—	P	P	—
1.900	5.15	—	—	48,26	7,66	—	—	7,62	—	—	P	—	P	P	—
2.063	3.24	—	3.25	52,40	—	—	4,84	3,96	PI	PI	PI	PI	PI	PI	—
2.063	4.50	—	—	52,40	—	—	—	5,72	P	P	P	P	P	P	P
2-3/8	4.00	—	—	60,32	5,95	—	—	4,24	PN	PN	PN	PN	PN	PN	—
2-3/8	4.60	4.70	—	60,32	6,85	6,99	—	4,83	PNU	PNU	PNU	PNU	PNU	PNU	PNU
2-3/8	5.80	5.95	—	60,32	8,63	8,85	—	6,45	—	—	PNU	PNU	PNU	PNU	PNU
2-3/8	6.60	—	—	60,32	9,82	—	—	7,49	—	—	P	—	P	P	—
2-3/8	7.35	7.45	—	60,32	10,94	11,09	—	8,53	—	—	PU	—	PU	PU	—
2-7/8	6.40	6.50	—	73,02	9,52	9,67	—	5,51	PNU	PNU	PNU	PNU	PNU	PNU	PNU
2-7/8	7.80	7.90	—	73,02	11,61	11,76	—	7,01	—	—	PNU	PNU	PNU	PNU	PNU
2-7/8	8.60	8.70	—	73,02	12,80	12,95	—	7,82	—	—	PNU	PNU	PNU	PNU	PNU
2-7/8	9.35	9.45	—	73,02	13,91	14,06	—	8,64	—	—	PU	—	PU	PU	—
2-7/8	10.50	—	—	73,02	15,63	—	—	9,96	—	—	P	—	P	P	—
2-7/8	11.50	—	—	73,02	17,11	—	—	11,18	—	—	P	—	P	P	—
3-1/2	7.70	—	—	88,90	11,46	—	—	5,49	PN	PN	PN	PN	PN	PN	—
3-1/2	9.20	9.30	—	88,90	13,69	13,84	—	6,45	PNU	PNU	PNU	PNU	PNU	PNU	PNU
3-1/2	10.20	—	—	88,90	15,18	—	—	7,34	PN	PN	PN	PN	PN	PN	—
3-1/2	12.70	12.95	—	88,90	18,90	19,27	—	9,52	—	—	PNU	PNU	PNU	PNU	PNU
3-1/2	14.30	—	—	88,90	21,28	—	—	10,92	—	—	P	—	P	P	—
3-1/2	15.50	—	—	88,90	23,07	—	—	12,09	—	—	P	—	P	P	—
3-1/2	17.00	—	—	88,90	25,30	—	—	13,46	—	—	P	—	P	P	—
4	9.50	—	—	101,60	14,14	—	—	5,74	PN	PN	PN	PN	PN	PN	—
4	10.70	11.00	—	101,60	—	16,37	—	6,65	PU	PU	PU	PU	PU	PU	—
4	13.20	—	—	101,60	19,64	—	—	8,38	—	—	P	—	P	P	—
4	16.10	—	—	101,60	23,96	—	—	10,54	—	—	P	—	P	P	—
4	18.90	—	—	101,60	28,13	—	—	12,70	—	—	P	—	P	P	—
4	22.20	—	—	101,60	33,04	—	—	15,49	—	—	P	—	P	P	—
4-1/2	12.60	12.75	—	114,30	18,75	18,97	—	6,88	PNU	PNU	PNU	PNU	PNU	PNU	—
4-1/2	15.20	—	—	114,30	22,62	—	—	8,56	—	—	P	—	P	P	—
4-1/2	17.00	—	—	114,30	25,30	—	—	9,65	—	—	P	—	P	P	—
4-1/2	18.90	—	—	114,30	28,13	—	—	10,92	—	—	P	—	P	P	—
4-1/2	21.50	—	—	114,30	32,00	—	—	12,70	—	—	P	—	P	P	—
4-1/2	23.70	—	—	114,30	35,27	—	—	14,22	—	—	P	—	P	P	—
4-1/2	26.10	—	—	114,30	38,84	—	—	16,00	—	—	P	—	P	P	—

P = Plain end, N = Non-upset threaded and coupled, U = External upset threaded and coupled, I = Integral joint.

<sup>a</sup> Nominal linear masses, threads and coupling (col. 2, 3, 4) are shown for information only.

<sup>b</sup> The densities of martensitic chromium steels (L80 types 9Cr and 13Cr) are different from carbon steels. The masses shown are therefore not accurate for martensitic chromium steels. A mass correction factor of 0,989 may be used.

<sup>c</sup> Non-upset tubing is available with regular couplings or special bevel couplings. External-upset tubing is available with regular, special-bevel, or special clearance couplings.

**Table C.4 — Process of manufacture and heat treatment**

Group	Grade	Type	Manufacturing process <sup>a</sup>	Heat treatment	Tempering temperature °C min.
1	2	3	4	5	6
1	H40	—	S or EW	None	—
	J55	—	S or EW	None <sup>b</sup>	—
	K55	—	S or EW	None <sup>b</sup>	—
	N80	1	S or EW	<sup>c</sup>	—
	N80	Q	S or EW	Q&T	—
2	M65	—	S or EW	<sup>d</sup>	—
	L80	1	S or EW	Q&T	566
	L80	9Cr	S	Q&T <sup>e</sup>	593
	L80	13Cr	S	Q&T <sup>e</sup>	593
	C90	1	S	Q&T	621
	C90	2	S	Q&T	621
	C95	—	S or EW	Q&T	538
	T95	1	S	Q&T	649
	T95	2	S	Q&T	649
	3	P110	—	S or EW <sup>f, g</sup>	Q&T
4	Q125	1	S or EW <sup>g</sup>	Q&T	—
	Q125	2	S or EW <sup>g</sup>	Q&T	—
	Q125	3	S or EW <sup>g</sup>	Q&T	—
	Q125	4	S or EW <sup>g</sup>	Q&T	—

<sup>a</sup> S = seamless process; EW = electric-welded process.

<sup>b</sup> Full length normalized (N), normalized and tempered (N&T), or quenched and tempered (Q&T), at the manufacturer's option or as specified on the purchase agreement.

<sup>c</sup> Full length normalized or normalized and tempered at the manufacturer's option.

<sup>d</sup> All pipe shall be full body heat-treated. Full length normalized (N), normalized and tempered (N&T), or quenched and tempered (Q&T), at the manufacturer's option or as specified on the purchase agreement.

<sup>e</sup> Type 9Cr and 13Cr may be air-quenched.

<sup>f</sup> Special chemical requirements for electric-welded P110 casing are specified in Table C.5.

<sup>g</sup> Special requirements unique to electric-welded P110 and Q125 are specified in A.6 (SR11).

**Table C.5 — Chemical composition, mass fraction (%)**

Group	Grade	Type	C		Mn		Mo		Cr		Ni	Cu	P	S	Si
			min.	max.	min.	max.	min.	max.	min.	max.	max.	max.	max.	max.	max.
1	2	3	4	5	6	7	8	9	10	11	12	13	14	15	16
1	H40	—	—	—	—	—	—	—	—	—	—	—	0,030	0,030	—
	J55	—	—	—	—	—	—	—	—	—	—	—	0,030	0,030	—
	K55	—	—	—	—	—	—	—	—	—	—	—	0,030	0,030	—
	N80	1	—	—	—	—	—	—	—	—	—	—	0,030	0,030	—
	N80	Q	—	—	—	—	—	—	—	—	—	—	0,030	0,030	—
2	M65	—	—	—	—	—	—	—	—	—	—	—	0,030	0,030	—
	L80	1	—	0,43 <sup>a</sup>	—	1,90	—	—	—	—	0,25	0,35	0,030	0,030	0,45
	L80	9Cr	—	0,15	0,30	0,60	0,90	1,10	8,00	10,0	0,50	0,25	0,020	0,010	1,00
	L80	13Cr	0,15	0,22	0,25	1,00	—	—	12,0	14,0	0,50	0,25	0,020	0,010	1,00
	C90	1	—	0,35	—	1,20	0,25 <sup>b</sup>	0,85	—	1,50	0,99	—	0,020	0,010	—
	C90	2	—	0,50	—	1,90	—	NL	—	NL	0,99	—	0,030	0,010	—
	C95	—	—	0,45 <sup>c</sup>	—	1,90	—	—	—	—	—	—	0,030	0,030	0,45
	T95	1	—	0,35	—	1,20	0,25 <sup>d</sup>	0,85	0,40	1,50	0,99	—	0,020	0,010	—
T95	2	—	0,50	—	1,90	—	—	—	—	0,99	—	0,030	0,010	—	
3	P110	e	—	—	—	—	—	—	—	—	—	—	0,030 <sup>e</sup>	0,030 <sup>e</sup>	—
4	Q125	1	—	0,35	—	1,35	—	0,85	—	1,50	0,99	—	0,020	0,010	—
	Q125	2	—	0,35	—	1,00	—	NL	—	NL	0,99	—	0,020	0,020	—
	Q125	3	—	0,50	—	1,90	—	NL	—	NL	0,99	—	0,030	0,010	—
	Q125	4	—	0,50	—	1,90	—	NL	—	NL	0,99	—	0,030	0,020	—

<sup>a</sup> The carbon content for L80 may be increased up to 0,50 % maximum if the product is oil-quenched.  
<sup>b</sup> The molybdenum content for Grade C90 Type 1 has no minimum tolerance if the wall thickness is less than 17,78 mm.  
<sup>c</sup> The carbon content for C95 may be increased up to 0,55 % maximum if the product is oil-quenched.  
<sup>d</sup> The molybdenum content for T95 Type 1 may be decreased to 0,15 % minimum if the wall thickness is less than 17,78 mm.  
<sup>e</sup> For EW Grade P110, the phosphorus content shall be 0,020 % maximum and the sulfur content 0,010 % maximum.  
 NL = no limit. Elements shown shall be reported in product analysis.



**Table C.6 — Tensile and hardness requirements**

Group	Grade	Type	Total elongation under load %	Yield strength MPa		Tensile strength min. MPa	Hardness <sup>a</sup> max.		Specified wall thickness mm	Allowable hardness variation <sup>b</sup> HRC
				min.	max.		HRC	HBW		
1	2	3	4	5	6	7	8	9	10	11
1	H40	—	0,5	276	552	414	—	—	—	—
	J55	—	0,5	379	552	517	—	—	—	—
	K55	—	0,5	379	552	655	—	—	—	—
	N80	1	0,5	552	758	689	—	—	—	—
	N80	Q	0,5	552	758	689	—	—	—	—
2	M65	—	0,5	448	586	586	22	235	—	—
	L80	1	0,5	552	655	655	23	241	—	—
	L80	9Cr	0,5	552	655	655	23	241	—	—
	L80	13Cr	0,5	552	655	655	23	241	—	—
	C90	1 & 2	0,5	621	724	689	25,4	255	≤ 12,70	3,0
	C90	1 & 2	0,5	621	724	689	25,4	255	12,71 to 19,04	4,0
	C90	1 & 2	0,5	621	724	689	25,4	255	19,05 to 25,39	5,0
	C90	1 & 2	0,5	621	724	689	25,4	255	≥ 25,40	6,0
	C95	—	0,5	655	758	724	—	—	—	—
	T95	1 & 2	0,5	655	758	724	25,4	255	≤ 12,70	3,0
	T95	1 & 2	0,5	655	758	724	25,4	255	12,71 to 19,04	4,0
	T95	1 & 2	0,5	655	758	724	25,4	255	19,05 to 25,39	5,0
T95	1 & 2	0,5	655	758	724	25,4	255	≥ 25,40	6,0	
3	P110	—	0,6	758	965	862	—	—	—	—
4	Q125	All	0,65	862	1034	931	b	—	≤ 12,70	3,0
	Q125	All	0,65	862	1034	931	b	—	12,71 to 19,04	4,0
	Q125	All	0,65	862	1034	931	b	—	≥ 19,05	5,0

<sup>a</sup> In case of dispute, laboratory Rockwell C hardness testing shall be used as the referee method.

<sup>b</sup> No hardness limits are specified, but the maximum variation is restricted as a manufacturing control in accordance with 7.8 and 7.9.

**Table C.7 — Elongation table**

Tensile test specimen				Minimum elongation in 50,8 mm							
				%							
				Grade							
				H40	J55	M65	K55 L80	N80 Type 1 N80Q C90	C95 T95	P110	Q125
Specimen area mm <sup>2</sup>	Specified wall thickness mm			Specified minimum tensile strength MPa							
	Specimen width 19 mm	Specimen width 25 mm	Specimen width 38 mm	414	517	586	655	689	724	862	931
1	2	3	4	5	6	7	8	9	10	11	12
490	≥ 25,53	≥ 19,41	≥ 12,77	30	24	22	20	19	18	15	14
480	25,00-25,52	19,00-19,40	12,51-12,76	29	24	22	20	19	18	15	14
470	24,48-24,99	18,61-18,99	12,24-12,50	29	24	21	19	19	18	15	14
460	23,95-24,47	18,20-18,60	11,98-12,23	29	24	21	19	18	18	15	14
450	23,43-23,94	17,81-18,19	11,72-11,97	29	24	21	19	18	18	15	14
440	22,90-23,42	17,40-17,80	11,45-11,71	29	24	21	19	18	18	15	14
430	22,37-22,89	17,01-17,39	11,19-11,44	29	24	21	19	18	17	15	14
420	21,85-22,36	16,60-17,00	10,93-11,18	29	24	21	19	18	17	15	14
410	21,32-21,84	16,21-16,59	10,66-10,92	29	23	21	19	18	17	15	14
400	20,79-21,31	15,80-16,20	10,40-10,65	28	23	21	19	18	17	15	14
390	20,27-20,78	15,41-15,79	10,14-10,39	28	23	21	19	18	17	15	14
380	19,74-20,26	15,00-15,40	9,87-10,13	28	23	21	19	18	17	15	14
370	19,22-19,73	14,61-14,99	9,61-9,86	28	23	20	19	18	17	14	13
360	18,69-19,21	14,20-14,60	9,35-9,60	28	23	20	18	18	17	14	13
350	18,16-18,68	13,81-14,19	9,08-9,34	28	23	20	18	18	17	14	13
340	17,64-18,15	13,40-13,80	8,82-9,07	28	23	20	18	17	17	14	13
330	17,11-17,63	13,01-13,39	8,56-8,81	27	22	20	18	17	17	14	13
320	16,58-17,10	12,60-13,00	8,29-8,55	27	22	20	18	17	16	14	13
310	16,06-16,57	12,21-12,59	8,03-8,28	27	22	20	18	17	16	14	13
300	15,53-16,05	11,80-12,20	7,77-8,02	27	22	20	18	17	16	14	13
290	15,01-15,52	11,41-11,79	7,51-7,76	27	22	20	18	17	16	14	13
280	14,48-15,00	11,00-11,40	7,24-7,50	26	22	19	18	17	16	14	13
270	13,95-14,47	10,61-10,99	6,98-7,23	26	22	19	17	17	16	14	13
260	13,43-13,94	10,20-10,60	6,72-6,97	26	21	19	17	16	16	13	13
250	12,90-13,42	9,81-10,19	6,45-6,71	26	21	19	17	16	16	13	12
240	12,37-12,89	9,40-9,80	6,19-6,44	26	21	19	17	16	16	13	12
230	11,85-12,36	9,01-9,39	5,93-6,18	25	21	19	17	16	15	13	12
220	11,32-11,84	8,60-9,00	5,66-5,92	25	21	18	17	16	15	13	12
210	10,79-11,31	8,21-8,59	5,40-5,65	25	20	18	17	16	15	13	12
200	10,27-10,78	7,80-8,20	5,14-5,39	25	20	18	16	16	15	13	12
190	9,74-10,26	7,41-7,79	4,87-5,13	24	20	18	16	15	15	13	12
180	9,22-9,73	7,00-7,40	4,61-4,86	24	20	18	16	15	15	13	12
170	8,69-9,21	6,61-6,99	4,35-4,60	24	20	18	16	15	14	12	12
160	8,16-8,68	6,20-6,60	4,08-4,34	24	19	17	16	15	14	12	11
150	7,64-8,15	5,81-6,19	3,82-4,07	23	19	17	15	15	14	12	11
140	7,11-7,63	5,40-5,80	3,56-3,81	23	19	17	15	15	14	12	11
130	6,58-7,10	5,01-5,39	3,29-3,55	23	19	17	15	14	14	12	11
120	6,06-6,57	4,60-5,00	3,03-3,28	22	18	16	15	14	14	12	11
110	5,53-6,05	4,21-4,59	2,77-3,02	22	18	16	15	14	13	11	11
100	5,01-5,52	3,80-4,20	2,51-2,76	22	18	16	14	14	13	11	10
90	4,48-5,00	3,41-3,79	2,24-2,50	21	17	15	14	13	13	11	10
80	3,95-4,47	3,00-3,40	1,98-2,23	21	17	15	14	13	12	11	10
70	3,43-3,94	2,61-2,99	1,72-1,97	20	16	15	13	13	12	10	10
60	2,90-3,42	2,20-2,60	1,45-1,71	19	16	14	13	12	12	10	9,5
50	2,37-2,89	1,81-2,19	1,19-1,44	19	15	14	12	12	11	9,5	9

**Table C.8 — Critical thickness for couplings with API threads**

Dimensions in millimetres

Label 1	Critical thickness for couplings						
	NU	EU	Special clearance		BC	LC	STC
			EU	BC			
1	2	3	4	5	6	7	8
1.050	4,29	5,36	—	—	—	—	—
1.315	5,36	6,55	—	—	—	—	—
1.660	6,07	6,10	—	—	—	—	—
1.900	4,98	6,38	—	—	—	—	—
2-3/8	7,72	7,62	5,69	—	—	—	—
2-7/8	9,65	9,09	6,45	—	—	—	—
3-1/2	11,46	11,53	7,47	—	—	—	—
4	11,53	11,63	—	—	—	—	—
4-1/2	11,05	12,52	—	6,58	8,18	8,86	8,56
5	—	—	—	6,76	9,14	9,96	9,45
5-1/2	—	—	—	6,81	9,04	9,88	9,40
6-5/8	—	—	—	6,96	11,91	12,90	12,32
7	—	—	—	7,11	10,67	11,63	10,92
7-5/8	—	—	—	8,84	13,61	14,55	13,87
8-5/8	—	—	—	8,94	15,29	16,43	15,54
9-5/8	—	—	—	8,94	15,29	16,69	15,60
10-3/4	—	—	—	8,94	15,29	—	15,70
11-3/4	—	—	—	—	15,29	—	15,70
13-3/8	—	—	—	—	15,29	—	15,70
16	—	—	—	—	16,94	—	16,05
18-5/8	—	—	—	—	21,69	—	20,80
20	—	—	—	—	16,94	17,09	16,10

NOTE The coupling blank thickness is greater than indicated above, due to thread height and manufacturing allowance to avoid black crest threads.

**Table C.9 — Acceptable size impact specimens and absorbed energy reduction factor**

Test specimen size	Specimen dimensions mm	Reduction factor
Full-size	10,0 × 10,0	1,00
¾-size	10,0 × 7,5	0,80
½-size	10,0 × 5,0	0,55

**Table C.10 — Hierarchy of test specimen orientation and size**

Choice	Orientation	Size
1st	Transverse	Full-size
2nd	Transverse	¾-size
3rd	Transverse	½-size
4th	Longitudinal	Full-size
5th	Longitudinal	¾-size
6th	Longitudinal	½-size

**Table C.11 — Charpy impact test specimen requirements for couplings Grades J55 and K55**

Label 1	API connection type and CVN specimen orientation, size, energy and temperature reduction						
	NU	EU	Special clearance <sup>b</sup>		BC	LC	STC
			EU	BC			
1	2	3	4	5	6	7	8
1.050	a	L-5-15-A	—	—	—	—	—
1.315	L-5-15-A	L-7-22-A	—	—	—	—	—
1.660	L-5-15-B	L-5-15-B	—	—	—	—	—
1.900	L-5-15-A	L-7-22-B	—	—	—	—	—
2-3/8	L-7-22-A	L-7-22-A	L-7-22-A	—	—	—	—
2-7/8	L-10-27-A	L-10-27-A	L-10-27-A	—	—	—	—
3-1/2	T-5-11-E	T-5-11-E	T-5-11-D	—	—	—	—
4	T-7-16-B	T-7-16-B	—	—	—	—	—
4-1/2	T-7-16-B	T-7-16-B	—	L-7-22-A	L-7-22-A	L-10-27-A	L-10-27-A
5	—	—	—	T-5-11-C	T-5-11-D	T-5-11-D	T-5-11-D
5-1/2	—	—	—	T-5-11-C	T-5-11-D	T-5-11-D	T-5-11-D
6-5/8	—	—	—	T-10-20-A	T-10-20-A	T-10-20-A	T-10-20-A
7	—	—	—	T-7-16-A	T-7-16-A	T-10-20-A	T-7-16-B
7-5/8	—	—	—	T-10-20-A	T-10-20-A	T-10-20-A	T-10-20-A
8-5/8	—	—	—	T-10-20-A	T-10-20-A	T-10-20-A	T-10-20-A
9-5/8	—	—	—	T-10-20-A	T-10-20-A	T-10-20-A	T-10-20-A
10-3/4	—	—	—	T-10-20-A	T-10-20-A	—	T-10-20-A
11-3/4	—	—	—	—	T-10-20-A	—	T-10-20-A
13-3/8	—	—	—	—	T-10-20-A	—	T-10-20-A
16	—	—	—	—	T-10-20-A	—	T-10-20-A
18-5/8	—	—	—	—	T-10-20-A	—	T-10-20-A
20	—	—	—	—	T-10-20-A	T-10-20-A	T-10-20-A

NOTE In this table, the specimen orientation (T or L) is followed by the minimum specimen size (10, 7 or 5) which is followed by the minimum absorbed energy requirement (joules) and the temperature reduction (A, B, C, D or E), according to the following code. Both the absorbed energy requirement and the test temperature reduction requirement are adjusted for the test specimen size indicated.

- T is the transverse specimen orientation (see Figure D.12)
- L is the longitudinal specimen orientation (see Figure D.12)
- 10 = full-size (i.e. 10 mm × 10 mm)
- 7 = ¾-size (i.e. 10 mm × 7,5 mm)
- 5 = ½-size (i.e. 10 mm × 5 mm)
- A = no temperature reduction
- B = 3 °C reduction
- C = 6 °C reduction
- D = 8 °C reduction
- E = 11 °C reduction

<sup>a</sup> Not thick enough to test.  
<sup>b</sup> The above assumes that special-clearance couplings are machined from standard couplings.

**Table C.12 — Charpy impact test specimen requirements for couplings Grade L80 all types**

Label 1	API connection type and CVN specimen orientation, size and energy						
	NU	EU	Special clearance <sup>b</sup>		BC	LC	STC
			EU	BC			
1	2	3	4	5	6	7	8
1.050	a	L-5-22	—	—	—	—	—
1.315	L-5-22	L-7-32	—	—	—	—	—
1.660	L-5-22	L-5-22	—	—	—	—	—
1.900	L-5-22	L-7-32	—	—	—	—	—
2-3/8	L-7-32	L-7-32	L-7-32	—	—	—	—
2-7/8	L-10-40	L-10-40	L-10-40	—	—	—	—
3-1/2	T-5-11	T-5-11	T-5-11	—	—	—	—
4	T-7-16	T-7-16	—	—	—	—	—
4-1/2	T-7-16	T-7-16	—	L-7-32	L-7-32	L-10-40	—
5	—	—	—	T-5-11	T-5-11	T-5-11	—
5-1/2	—	—	—	T-5-11	T-5-11	T-5-11	—
6-5/8	—	—	—	T-10-20	T-10-20	T-10-20	—
7	—	—	—	T-7-16	T-7-16	T-10-20	—
7-5/8	—	—	—	T-10-20	T-10-20	T-10-20	—
8-5/8	—	—	—	T-10-20	T-10-20	T-10-21	—
9-5/8	—	—	—	T-10-20	T-10-20	T-10-21	—
10-3/4	—	—	—	T-10-20	T-10-20	—	T-10-20
11-3/4	—	—	—	—	T-10-20	—	T-10-20
13-3/8	—	—	—	—	T-10-20	—	T-10-20
16	—	—	—	—	T-10-21	—	T-10-21
18-5/8	—	—	—	—	T-10-25	—	T-10-24
20	—	—	—	—	T-10-21	T-10-21	T-10-21

NOTE In this table, the specimen orientation (T or L) is followed by the minimum specimen size (10, 7 or 5) which is followed by the minimum absorbed energy requirement (joules) according to the following code. The absorbed energy requirement is adjusted for the test specimen size indicated.

T is the transverse specimen orientation (see Figure D.12)  
L is the longitudinal specimen orientation (see Figure D.12)  
10 = full-size (i.e. 10 mm × 10 mm)  
7 = ¾-size (i.e. 10 mm × 7,5 mm)  
5 = ½-size (i.e. 10 mm × 5 mm)

<sup>a</sup> Not thick enough to test.  
<sup>b</sup> The above assumes that special clearance couplings are machined from standard couplings.

**Table C.13 — Charpy impact test specimen requirements for couplings Grade C90**

Label 1	API connection type and CVN specimen orientation, size and energy						STC
	NU	EU	Special clearance <sup>b</sup>		BC	LC	
			EU	BC			
1	2	3	4	5	6	7	8
1.050	a	L-5-22	—	—	—	—	—
1.315	L-5-22	L-7-32	—	—	—	—	—
1.660	L-5-22	L-5-22	—	—	—	—	—
1.900	L-5-22	L-7-32	—	—	—	—	—
2-3/8	L-7-32	L-7-32	L-7-32	—	—	—	—
2-7/8	L-10-40	L-10-40	L-10-40	—	—	—	—
3-1/2	T-5-11	T-5-11	T-5-11	—	—	—	—
4	T-7-16	T-7-16	—	—	—	—	—
4-1/2	T-7-16	T-7-16	—	L-7-32	L-7-32	L-10-40	—
5	—	—	—	T-5-11	T-5-11	T-5-11	—
5-1/2	—	—	—	T-5-11	T-5-11	T-5-11	—
6-5/8	—	—	—	T-10-20	T-10-20	T-10-20	—
7	—	—	—	T-7-16	T-7-16	T-10-20	—
7-5/8	—	—	—	T-10-20	T-10-21	T-10-22	—
8-5/8	—	—	—	T-10-20	T-10-22	T-10-23	—
9-5/8	—	—	—	T-10-20	T-10-22	T-10-23	—
10-3/4	—	—	—	T-10-20	T-10-22	—	T-10-23
11-3/4	—	—	—	—	T-10-22	—	T-10-23
13-3/8	—	—	—	—	T-10-22	—	T-10-23
16	—	—	—	—	—	—	—
18-5/8	—	—	—	—	—	—	—
20	—	—	—	—	—	—	—

NOTE In this table, the specimen orientation (T or L) is followed by the minimum specimen size (10, 7 or 5) which is followed by the minimum absorbed energy requirement (joules) according to the following code. The absorbed energy requirement is adjusted for the test specimen size indicated.

T is the transverse specimen orientation (see Figure D.12)  
L is the longitudinal specimen orientation (see Figure D.12)  
10 = full-size (i.e. 10 mm × 10 mm)  
7 = ¾-size (i.e. 10 mm × 7,5 mm)  
5 = ½-size (i.e. 10 mm × 5 mm)

<sup>a</sup> Not thick enough to test.  
<sup>b</sup> The above assumes that special-clearance couplings are machined from standard couplings.

**Table C.14 — Charpy impact test specimen requirements for couplings —  
Grades N80 Type 1, N80Q, C95 and T95**

Label 1	API connection type and CVN specimen orientation, size and energy						
	NU	EU	Special clearance <sup>b</sup>		BC	LC	STC
			EU	BC			
1	2	3	4	5	6	7	8
1.050	a	L-5-22	—	—	—	—	—
1.315	L-5-22	L-7-32	—	—	—	—	—
1.660	L-5-22	L-5-22	—	—	—	—	—
1.900	L-5-22	L-7-32	—	—	—	—	—
2-3/8	L-7-32	L-7-32	L-7-32	—	—	—	—
2-7/8	L-10-40	L-10-40	L-10-40	—	—	—	—
3-1/2	T-5-11	T-5-11	T-5-11	—	—	—	—
4	T-7-16	T-7-16	—	—	—	—	—
4-1/2	T-7-16	T-7-21	—	L-7-32	L-7-32	L-10-40	—
5	—	—	—	T-5-11	T-5-11	T-5-11	—
5-1/2	—	—	—	T-5-11	T-5-11	T-5-11	—
6-5/8	—	—	—	T-10-20	T-10-20	T-10-21	—
7	—	—	—	T-7-16	T-7-16	T-10-20	—
7-5/8	—	—	—	T-10-20	T-10-22	T-10-23	—
8-5/8	—	—	—	T-10-20	T-10-23	T-10-24	—
9-5/8	—	—	—	T-10-20	T-10-23	T-10-24	—
10-3/4	—	—	—	T-10-20	T-10-23	—	T-10-24
11-3/4	—	—	—	—	T-10-23	—	T-10-24
13-3/8	—	—	—	—	T-10-23	—	T-10-24
16	—	—	—	—	—	—	—
18-5/8	—	—	—	—	—	—	—
20	—	—	—	—	—	—	—

NOTE In this table, the specimen orientation (T or L) is followed by the minimum specimen size (10, 7 or 5) which is followed by the minimum absorbed energy requirement (joules) according to the following code. The absorbed energy requirement is adjusted for the test specimen size indicated.

T is the transverse specimen orientation (see Figure D.12)  
L is the longitudinal specimen orientation (see Figure D.12)  
10 = full-size (i.e. 10 mm × 10 mm)  
7 = ¾-size (i.e. 10 mm × 7,5 mm)  
5 = ½-size (i.e. 10 mm × 5 mm)

<sup>a</sup> Not thick enough to test.  
<sup>b</sup> The above assumes that special clearance couplings are machined from standard couplings.

**Table C.15 — Charpy impact test specimen requirements for couplings Grade P110**

Label 1	API connection type and CVN specimen orientation, size and energy						
	NU	EU	Special clearance <sup>b</sup>		BC	LC	STC
			EU	BC			
1	2	3	4	5	6	7	8
1.050	a	L-5-22	—	—	—	—	—
1.315	L-5-22	L-7-32	—	—	—	—	—
1.660	L-5-22	L-5-22	—	—	—	—	—
1.900	L-5-22	L-7-32	—	—	—	—	—
2-3/8	L-7-34	L-7-33	L-7-32	—	—	—	—
2-7/8	L-10-46	L-10-45	L-10-40	—	—	—	—
3-1/2	T-5-14	T-5-14	T-5-11	—	—	—	—
4	T-7-20	T-7-20	—	—	—	—	—
4-1/2	T-7-20	T-7-21	—	L-7-32	L-7-34	L-10-44	—
5	—	—	—	T-5-11	T-5-12	T-5-13	—
5-1/2	—	—	—	T-5-11	T-5-12	T-5-13	—
6-5/8	—	—	—	T-10-20	T-10-26	T-10-26	—
7	—	—	—	T-7-16	T-7-19	T-10-25	—
7-5/8	—	—	—	T-10-22	T-10-28	T-10-29	—
8-5/8	—	—	—	T-10-22	T-10-30	T-10-31	—
9-5/8	—	—	—	T-10-22	T-10-30	T-10-31	T-10-30
10-3/4	—	—	—	T-10-22	T-10-30	—	T-10-30
11-3/4	—	—	—	—	T-10-30	—	T-10-30
13-3/8	—	—	—	—	T-10-30	—	—
16	—	—	—	—	—	—	—
18-5/8	—	—	—	—	—	—	—
20	—	—	—	—	—	—	—

NOTE In this table, the specimen orientation (T or L) is followed by the minimum specimen size (10, 7 or 5) which is followed by the minimum absorbed energy requirement (joules) according to the following code. The absorbed energy requirement is adjusted for the test specimen size indicated.

- T is the transverse specimen orientation (see Figure D.12)
- L is the longitudinal specimen orientation (see Figure D.12)
- 10 = full-size (i.e. 10 mm × 10 mm)
- 7 = ¾-size (i.e. 10 mm × 7,5 mm)
- 5 = ½-size (i.e. 10 mm × 5 mm)

<sup>a</sup> Not thick enough to test.  
<sup>b</sup> The above assumes that special-clearance couplings are machined from standard couplings.



**Table C.16 — Charpy impact test specimen requirements for couplings Grade Q125**

Label 1	API connection type and CVN specimen orientation, size and energy			
	Special clearance <sup>a</sup>	BC	LC	STC
	BC			
1	2	3	4	5
4-1/2	L-7-34	L-7-34	L-10-48	—
5	T-5-12	T-5-13	T-5-14	—
5-1/2	T-5-12	T-5-13	T-5-14	—
6-5/8	T-10-22	T-10-28	T-10-29	—
7	T-7-17	T-7-21	T-10-27	—
7-5/8	T-10-24	T-10-30	T-10-31	—
8-5/8	T-10-24	T-10-32	T-10-33	—
9-5/8	T-10-24	T-10-32	T-10-33	—
10-3/4	T-10-24	T-10-32	—	T-10-32
11-3/4	—	T-10-32	—	T-10-32
13-3/8	—	T-10-32	—	T-10-32
16	—	—	—	—
18-5/8	—	—	—	—
20	—	—	—	—

NOTE In this table, the specimen orientation (T or L) is followed by the minimum specimen size (10, 7 or 5) which is followed by the minimum absorbed energy requirement (joules) according to the following code. The absorbed energy requirement is adjusted for the test specimen size indicated.

T is the transverse specimen orientation (see Figure D.12)  
L is the longitudinal specimen orientation (see Figure D.12)  
10 = full-size (i.e. 10 mm × 10 mm)  
7 = ¾-size (i.e. 10 mm × 7,5 mm)  
5 = ½-size (i.e. 10 mm × 5 mm)

<sup>a</sup> The above assumes that special-clearance couplings are machined from standard couplings.

**Table C.17 — Transverse Charpy absorbed energy requirements for couplings**

Maximum critical thickness for various grades mm					Minimum transverse absorbed energy J
L80	C90	N80Q, C95, T95	P110	Q125	
1	2	3	4	5	6
15,85	13,32	12,24	7,33	6,13	20
17,14	14,49	13,36	8,21	6,95	21
18,44	15,66	14,48	9,08	7,77	22
19,73	16,83	15,60	9,96	8,59	23
21,02	18,00	16,72	10,84	9,41	24
22,32	19,17	17,83	11,72	10,23	25
23,61	20,34	18,95	12,60	11,04	26
24,91	21,51	20,07	13,48	11,86	27
26,20	22,69	21,19	14,35	12,68	28
	23,86	22,31	15,23	13,50	29
	25,03	23,43	16,11	14,32	30
	26,20	24,54	16,99	15,14	31
		25,66	17,87	15,96	32
			18,75	16,78	33
			19,62	17,60	34
			20,50	18,42	35
			21,38	19,24	36
			22,26	20,06	37
			23,14	20,88	38
			24,01	21,70	39
			24,89	22,52	40
			25,77	23,34	41
				24,16	42
				24,98	43
				25,80	44

For critical thickness greater than shown above, the requirements shall be according to the equations for the wall thickness and grade.

NOTE 1 Critical thicknesses greater than shown in Table C.8 are not applicable for couplings with API threads and are shown here for information for special applications.

NOTE 2 Grade M65 is not mentioned in this table, because it is furnished with Grade L80 Type 1 couplings.

**Table C.18 — Longitudinal Charpy absorbed energy requirements for couplings**

Maximum critical thickness mm					Minimum longitudinal absorbed energy J
L80	C90	N80Q, C95, T95	P110	Q125	
1	2	3	4	5	6
16,17	13,61	12,52	7,55	6,33	41
16,82	14,20	13,08	7,99	6,74	42
17,47	14,78	13,64	8,43	7,15	43
18,11	15,37	14,20	8,87	7,56	44
18,76	15,95	14,76	9,30	7,97	45
19,41	16,54	15,32	9,74	8,38	46
20,05	17,13	15,88	10,18	8,79	47
20,70	17,71	16,44	10,62	9,20	48
21,35	18,30	17,00	11,06	9,61	49
21,99	18,88	17,56	11,50	10,02	50
22,64	19,47	18,11	11,94	10,43	51
23,29	20,05	18,67	12,38	10,84	52
23,94	20,64	19,23	12,82	11,25	53
24,58	21,22	19,79	13,26	11,66	54
25,23	21,81	20,35	13,70	12,07	55
25,88	22,39	20,91	14,13	12,48	56
	22,98	21,47	14,57	12,89	57
	23,56	22,03	15,01	13,30	58
	24,15	22,59	15,45	13,71	59
	24,73	23,15	15,89	14,12	60
	25,32	23,70	16,33	14,53	61
	25,90	24,26	16,77	14,94	62
		24,82	17,21	15,35	63
		25,38	17,65	15,76	64
		25,94	18,09	16,17	65
			18,53	16,58	66
			18,96	16,99	67
			19,40	17,40	68
			19,84	17,81	69
			20,28	18,22	70

For critical thickness greater than shown above, the requirements shall be according to the equations for the wall thickness and grade.

NOTE 1 Critical thicknesses greater than shown in Table C.8 are not applicable for couplings with API threads and are shown here for information for special applications.

NOTE 2 Grade M65 is not mentioned in this table, because it is furnished with Grade L80 Type 1 couplings.

**Table C.19 — Transverse Charpy absorbed energy requirements for pipe**

Maximum specified wall thickness mm					Minimum transverse absorbed energy J
N80Q, L80	C90	C95, T95	P110	Q125	
1	2	3	4	5	6
11,59	9,11	8,09	—	—	14
13,12	10,48	9,38	—	—	15
14,66	11,84	10,67	—	—	16
16,19	13,21	11,97	—	—	17
17,73	14,57	13,26	—	—	18
19,26	15,94	14,56	—	—	19
20,80	17,30	15,85	12,24	6,13	20
22,33	18,67	17,14	13,36	6,95	21
23,87	20,03	18,44	14,48	7,77	22
25,40	21,40	19,73	15,60	8,59	23
	22,76	21,02	16,72	9,41	24
	24,12	22,32	17,83	10,23	25
	25,49	23,61	18,95	11,04	26
		24,91	20,07	11,86	27
			21,19	12,68	28
			22,31	13,50	29
			23,43	14,32	30
			24,54	15,14	31
			25,66	15,96	32
				16,78	33
				17,60	34
				18,42	35
				19,24	36
				20,06	37
				20,88	38
				21,70	39
				22,52	40
				23,34	41
				24,16	42
				24,98	43
				25,80	44

For wall thicknesses greater than shown above, the requirements shall be according to the equations for the wall thickness and grade.

NOTE Wall thicknesses greater than those of standard ISO/API pipe are shown here for information for special applications.

**Table C.20 — Longitudinal Charpy absorbed energy requirements for pipe**

Maximum specified wall thickness mm					Minimum longitudinal absorbed energy J
N80Q, L80	C90	C95, T95	P110	Q125	
1	2	3	4	5	6
10,44	8,09	7,12	—	—	27
11,20	8,77	7,76	—	—	28
11,97	9,45	8,41	—	—	29
12,74	10,14	9,06	—	—	30
13,51	10,82	9,70	—	—	31
14,27	11,50	10,35	—	—	32
15,04	12,18	11,00	—	—	33
15,81	12,87	11,64	—	—	34
16,58	13,55	12,29	—	—	35
17,34	14,23	12,94	—	—	36
18,11	14,91	13,58	—	—	37
18,88	15,60	14,23	—	—	38
19,65	16,28	14,88	—	—	39
20,41	16,96	15,53	—	—	40
21,18	17,64	16,17	12,52	6,33	41
21,95	18,32	16,82	13,08	6,74	42
22,72	19,01	17,47	13,64	7,15	43
23,48	19,69	18,11	14,20	7,56	44
24,25	20,37	18,76	14,76	7,97	45
25,02	21,05	19,41	15,32	8,38	46
25,79	21,74	20,05	15,88	8,79	47
	22,42	20,70	16,44	9,20	48
	23,10	21,35	17,00	9,61	49
	23,78	21,99	17,56	10,02	50
	24,47	22,64	18,11	10,43	51
	25,15	23,29	18,67	10,84	52
	25,83	23,94	19,23	11,25	53
		24,58	19,79	11,66	54
		25,23	20,35	12,07	55
		25,88	20,91	12,48	56
			21,47	12,89	57
			22,03	13,30	58
			22,59	13,71	59
			23,15	14,12	60
			23,70	14,53	61
			24,26	14,94	62
			24,82	15,35	63
			25,38	15,76	64
			25,94	16,17	65
				16,58	66
				16,99	67
				17,40	68
				17,81	69
				18,22	70
				18,63	71
				19,04	72

For wall thicknesses greater than shown above, the requirements shall be according to the equations for the wall thickness and grade.

NOTE Wall thicknesses greater than those of standard ISO/API pipe are shown here for information for special applications.

**Table C.21 — Transverse impact specimen size required for pipe in quenched and tempered grades**

Label 1	Calculated wall thickness required to machine transverse Charpy impact specimens mm		
	Full-size	¾-size	½-size
1	2	3	4
3-1/2	20,53	18,03	15,53
4	19,09	16,59	14,09
4-1/2	18,05	15,55	13,05
5	17,26	14,76	12,26
5-1/2	16,64	14,14	11,64
6-5/8	15,62	13,12	10,62
7	15,36	12,86	10,36
7-5/8	14,99	12,49	9,99
7-3/4	14,92	12,42	9,92
8-5/8	14,51	12,01	9,51
9-5/8	14,13	11,63	9,13
10-3/4	13,80	11,30	8,80
11-3/4	13,56	11,06	8,56
13-3/8	13,24	10,74	8,24
16	12,87	10,37	7,87
18-5/8	12,60	10,10	7,60
20	12,49	9,99	7,49

NOTE The wall thicknesses in columns 2, 3 and 4 that are in excess of the maximum wall thicknesses for ISO/API pipe are for information only. The above provides a 0,50 mm ID and a 0,50 mm OD machining allowance.

**Table C.22 — Longitudinal impact specimen size required for pipe in quenched and tempered grades**

Label 1	Calculated wall thickness required to machine longitudinal Charpy impact specimens mm		
	Full-size	¾-size	½-size
1	2	3	4
1.050	11,97	9,47	6,97
1.315	11,77	9,27	6,77
1.660	11,60	9,10	6,60
1.900	11,52	9,02	6,52
2.063	11,48	8,98	6,48
2-3/8	11,42	8,92	6,42
2-7/8	11,34	8,84	6,34
3-1/2	11,28	8,78	6,28
4	11,25	8,75	6,25
4-1/2	11,22	8,72	6,22
5	11,20	8,70	6,20
5-1/2	11,18	8,68	6,18
6-5/8	11,15	8,65	6,15
7	11,14	8,64	6,14
7-5/8	11,13	8,63	6,13
7-3/4	11,13	8,63	6,13
8-5/8	11,11	8,61	6,11
9-5/8	11,10	8,60	6,10
10-3/4	11,09	8,59	6,09
11-3/4	11,08	8,58	6,08
13-3/8	11,07	8,57	6,07
16	11,06	8,56	6,06
18-5/8	11,05	8,55	6,05
20	11,05	8,55	6,05

NOTE The wall thicknesses in columns 2, 3 and 4 that are in excess of the maximum wall thicknesses for ISO/API pipe are for information only. The above provides a 0,50 mm ID and a 0,50 mm OD machining allowance.

**Table C.23 — Distance between plates for electric-weld flattening tests**

Grade	<i>D/t</i> ratio	Maximum distance between plates mm
H40	≥ 16	0,5 × <i>D</i>
	< 16	<i>D</i> × (0,830 – 0,020 6 <i>D/t</i> )
J55 & K55	≥ 16	0,65 × <i>D</i>
	3,93 to 16	<i>D</i> × (0,980 – 0,020 6 <i>D/t</i> )
	< 3,93	<i>D</i> × (1,104 – 0,051 8 <i>D/t</i> )
M65 N80 Type 1, N80Q <sup>a</sup> L80 Type 1 C95 <sup>a</sup> P110 <sup>b</sup> Q125 <sup>b</sup>	All	<i>D</i> × (1,074 – 0,019 4 <i>D/t</i> )
	9 to 28	<i>D</i> × (1,074 – 0,019 4 <i>D/t</i> )
	9 to 28	<i>D</i> × (1,074 – 0,019 4 <i>D/t</i> )
	9 to 28	<i>D</i> × (1,080 – 0,017 8 <i>D/t</i> )
	All	<i>D</i> × (1,086 – 0,016 3 <i>D/t</i> )
	All	<i>D</i> × (1,092 – 0,014 0 <i>D/t</i> )
<i>D</i> is the specified outside diameter of pipe, in millimetres.		
<i>t</i> is the specified wall thickness of the pipe, in millimetres.		
<sup>a</sup> If the flattening test fails at 12 o'clock or 6 o'clock, the flattening shall continue until the remaining portion of the specimen fails at the 3 o'clock or 9 o'clock position. Premature failure at 12 o'clock or 6 o'clock shall not be considered basis for rejection.		
<sup>b</sup> See A.6 (SR11). Flattening shall be at least 0,85 × <i>D</i> .		

**Table C.24 — Dimensions and masses for standard casing and for casing threaded with API round thread, buttress thread and extreme-line connections**

Labels <sup>a</sup>		Outside diameter	Nominal linear mass T&C <sup>b, c</sup>	Wall thickness	Inside diameter	Drift diameter	Plain end	Calculated mass <sup>c</sup>					
								$e_m$ , mass gain or loss due to end finishing <sup>d</sup>					
		<i>D</i> mm	kg/m	<i>t</i> mm	<i>d</i> mm	mm	$w_{pe}$ kg/m	kg		kg		kg	
1	2							Round thread	Buttress thread	Extreme-line			
							Short	Long	Reg. OD	SCC	Standard	Optional	
1	2	3	4	5	6	7	8	9	10	11	12	13	14
4-1/2	9.50	114,30	14,14	5,21	103,88	100,70	14,02	1,91	—	—	—	—	—
4-1/2	10.50	114,30	15,63	5,69	102,92	99,74	15,24	1,72	—	2,27	1,16	—	—
4-1/2	11.60	114,30	17,26	6,35	101,60	98,42	16,91	1,54	1,72	2,09	0,98	—	—
4-1/2	13.50	114,30	20,09	7,37	99,56	96,38	19,44	—	1,45	1,81	0,71	—	—
4-1/2	15.10	114,30	22,47	8,56	97,18	94,00	22,32	—	1,27	1,45	0,34	—	—
5	11.50	127,00	17,11	5,59	115,82	112,64	16,74	2,45	—	—	—	—	—
5	13.00	127,00	19,35	6,43	114,14	110,96	19,12	2,18	2,63	2,99	1,10	—	—
5	15.00	127,00	22,32	7,52	111,96	108,78	22,16	1,91	2,36	2,63	0,73	2,09	—
5	18.00	127,00	26,79	9,19	108,62	105,44	26,70	—	1,91	2,00	0,10	0,64	—
5	21.40	127,00	31,85	11,10	104,80	101,62	31,73	—	1,34	1,12	-0,78	—	—
5	23.20	127,00	34,53	12,14	102,72	99,54	34,39	—	1,04	0,93	-0,95	—	—
5	24.10	127,00	35,86	12,70	101,60	98,42	35,80	—	0,88	0,56	-1,33	—	—
5-1/2	14.00	139,70	20,83	6,20	127,30	124,12	20,41	2,45	—	—	—	—	—
5-1/2	15.50	139,70	23,07	6,98	125,74	122,56	22,85	2,18	2,63	2,90	0,95	2,63	1,91
5-1/2	17.00	139,70	25,30	7,72	124,26	121,08	25,13	2,00	2,45	2,63	0,68	2,18	1,45
5-1/2	20.00	139,70	29,76	9,17	121,36	118,18	29,52	—	2,00	2,09	0,14	0,64	-0,09
5-1/2	23.00	139,70	34,23	10,54	118,62	115,44	33,57	—	1,45	1,54	-0,41	0,00	-0,73
5-1/2	26.80	139,70	39,88	12,70	114,30	111,12	39,78	—	—	—	—	—	—
5-1/2	29.70	139,70	44,20	14,27	111,16	107,98	44,14	—	—	—	—	—	—
5-1/2	32.60	139,70	48,51	15,88	107,94	104,76	48,49	—	—	—	—	—	—
5-1/2	35.30	139,70	52,53	17,45	104,80	101,62	52,61	—	—	—	—	—	—
5-1/2	38.00	139,70	56,55	19,05	101,60	98,42	56,68	—	—	—	—	—	—
5-1/2	40.50	139,70	60,27	20,62	98,46	95,28	60,55	—	—	—	—	—	—
5-1/2	43.10	139,70	64,14	22,22	95,26	92,08	64,38	—	—	—	—	—	—
6-5/8	20.00	168,28	29,76	7,32	153,64	150,46	29,06	4,99	6,17	6,53	1,08	—	—
6-5/8	24.00	168,28	35,72	8,94	150,40	147,22	35,13	4,35	5,44	5,72	0,26	1,54	0,82
6-5/8	28.00	168,28	41,67	10,59	147,10	143,92	41,18	—	4,63	4,81	-0,64	0,09	-0,64
6-5/8	32.00	168,28	47,62	12,06	144,16	140,98	46,46	—	3,99	4,08	-1,37	-0,64	-1,36
7	17.00	177,80	25,30	5,87	166,06	162,88	24,89	4,54	—	—	—	—	—
7	20.00	177,80	29,76	6,91	163,98	160,80	29,12	4,26	—	—	—	—	—
7	23.00	177,80	34,23	8,05	161,70	158,75 <sup>e</sup>	33,70	3,63	4,72	4,99	0,73	2,72	1,91
7	23.00	177,80	34,23	8,05	161,70	158,52	33,70	3,63	4,72	4,99	0,73	2,72	1,91
7	26.00	177,80	38,69	9,19	159,42	156,24	38,21	3,27	4,26	4,35	0,09	1,27	0,45
7	29.00	177,80	43,16	10,36	157,08	153,90	42,78	—	3,63	3,72	-0,54	0,27	-0,54
7	32.00	177,80	47,62	11,51	154,78	152,40 <sup>e</sup>	47,20	—	2,99	3,08	-1,18	-0,27	-1,09
7	32.00	177,80	47,62	11,51	154,78	151,60	47,20	—	2,99	3,08	-1,18	-0,27	-1,09
7	35.00	177,80	52,09	12,65	152,50	149,32	51,52	—	2,54	2,54	-1,72	0,45	-0,82
7	38.00	177,80	56,55	13,72	150,36	147,18	55,52	—	2,00	1,91	-2,36	-0,09	-1,36
7	42.70	177,80	63,54	15,88	146,04	142,86	63,41	—	—	—	—	—	—
7	46.40	177,80	69,05	17,45	142,90	139,72	69,01	—	—	—	—	—	—
7	50.10	177,80	74,56	19,05	139,70	136,52	74,58	—	—	—	—	—	—
7	53.60	177,80	79,77	20,62	136,56	133,38	79,93	—	—	—	—	—	—
7	57.10	177,80	84,97	22,22	133,36	130,18	85,25	—	—	—	—	—	—

See notes at end of table.



Table C.24 (continued)

Labels <sup>a</sup>		Outside diameter	Nominal linear mass T&C <sup>b, c</sup>	Wall thickness	Inside diameter	Drift diameter	Calculated mass <sup>c</sup>						
							Plain end	$e_m$ , mass gain or loss due to end finishing <sup>d</sup>					
1	2	D mm	kg/m	t mm	d mm	mm		$w_{pe}$ kg/m	kg		kg		kg
							Round thread		Buttress thread	Extreme-line			
1	2	3	4	5	6	7	8	Short	Long	Reg. OD	SCC	Standard	Optional
1	2	3	4	5	6	7	8	9	10	11	12	13	14
7-5/8	24.00	193,68	35,72	7,62	178,44	175,26	34,96	7,17	—	—	—	—	—
7-5/8	26.40	193,68	39,29	8,33	177,02	173,84	38,08	6,89	8,62	9,34	2,82	2,90	1,81
7-5/8	29.70	193,68	44,20	9,52	174,64	171,46	43,24	—	7,89	8,53	2,00	1,18	0,09
7-5/8	33.70	193,68	50,15	10,92	171,84	168,66	49,22	—	7,17	7,71	1,18	0,00	-1,09
7-5/8	39.00	193,68	58,04	12,70	168,28	165,10	56,68	—	6,17	6,62	0,10	-1,00	-2,09
7-5/8	42.80	193,68	63,69	14,27	165,14	161,96	63,14	—	5,45	5,17	-1,37	—	—
7-5/8	45.30	193,68	67,41	15,11	163,46	160,28	66,54	—	5,01	5,01	-1,52	—	—
7-5/8	47.10	193,68	70,09	15,88	161,92	158,74	69,63	—	4,61	4,19	-2,35	—	—
7-5/8	51.20	193,68	76,19	17,45	158,78	155,60	75,84	—	—	—	—	—	—
7-5/8	55.30	193,68	82,30	19,05	155,58	152,40	82,04	—	—	—	—	—	—
7-3/4	46.10	196,85	68,60	15,11	166,63	165,10 <sup>e</sup>	67,72	—	—	—	—	—	—
7-3/4	46.10	196,85	68,60	15,11	166,63	163,45	67,72	—	—	—	—	—	—
8-5/8	24.00	219,08	35,72	6,71	205,66	202,48	35,14	10,70	—	—	—	—	—
8-5/8	28.00	219,08	41,67	7,72	203,64	200,46	40,24	10,07	—	—	—	—	—
8-5/8	32.00	219,08	47,62	8,94	201,20	200,02 <sup>e</sup>	46,33	9,43	12,52	12,79	2,74	5,99	3,99
8-5/8	32.00	219,08	47,62	8,94	201,20	198,02	46,33	9,43	12,52	12,79	2,74	5,99	3,99
8-5/8	36.00	219,08	53,57	10,16	198,76	195,58	52,35	8,80	11,61	11,88	1,83	3,45	1,91
8-5/8	40.00	219,08	59,53	11,43	196,22	193,68 <sup>e</sup>	58,53	—	10,80	10,98	0,92	1,81	0,27
8-5/8	40.00	219,08	59,53	11,43	196,22	193,04	58,53	—	10,80	10,98	0,92	1,81	0,27
8-5/8	44.00	219,08	65,48	12,70	193,68	190,50	64,64	—	9,89	10,07	0,01	0,73	-0,82
8-5/8	49.00	219,08	72,92	14,15	190,78	187,60	71,51	—	8,89	8,98	-1,08	-0,36	-1,91
9-5/8	32.30	244,48	48,07	7,92	228,60	224,66	46,20	11,07	—	—	—	—	—
9-5/8	36.00	244,48	53,57	8,94	226,60	222,63	51,93	10,43	14,51	14,06	2,94	—	—
9-5/8	40.00	244,48	59,53	10,03	224,40	222,25 <sup>e</sup>	57,99	9,71	13,61	13,15	2,03	4,81	3,27
9-5/8	40.00	244,48	59,53	10,03	224,40	220,45	57,99	9,71	13,61	13,15	2,03	4,81	3,27
9-5/8	43.50	244,48	64,74	11,05	222,40	218,41	63,61	—	12,79	12,34	1,22	2,45	0,91
9-5/8	47.00	244,48	69,94	11,99	220,50	216,54	68,75	—	12,07	11,61	0,49	1,00	-0,54
9-5/8	53.50	244,48	79,62	13,84	216,80	215,90 <sup>e</sup>	78,72	—	10,61	10,16	-0,96	-0,54	-2,09
9-5/8	53.50	244,48	79,62	13,84	216,80	212,83	78,72	—	10,61	10,16	-0,96	-0,54	-2,09
9-5/8	58.40	244,48	86,91	15,11	214,25	212,72 <sup>e</sup>	85,47	—	9,75	9,13	-2,00	—	—
9-5/8	58.40	244,48	86,91	15,11	214,25	210,29	85,47	—	9,75	9,13	-2,00	—	—
9-5/8	59.40	244,48	88,40	15,47	213,50	209,58	87,37	—	—	—	—	—	—
9-5/8	64.90	244,48	96,58	17,07	210,30	206,38	95,73	—	—	—	—	—	—
9-5/8	70.30	244,48	104,62	18,64	207,20	203,23	103,82	—	—	—	—	—	—
9-5/8	75.60	244,48	112,51	20,24	204,00	200,02	111,93	—	—	—	—	—	—
10-3/4	32.75	273,05	48,74	7,09	258,90	254,91	46,50	13,15	—	—	—	—	—
10-3/4	40.50	273,05	60,27	8,89	255,30	251,31	57,91	11,97	—	15,60	3,27	—	—
10-3/4	45.50	273,05	67,71	10,16	252,70	250,82 <sup>e</sup>	65,87	11,07	—	14,42	2,09	9,62	—
10-3/4	45.50	273,05	67,71	10,16	252,70	248,77	65,87	11,07	—	14,42	2,09	9,62	—
10-3/4	51.00	273,05	75,90	11,43	250,20	246,23	73,75	10,25	—	13,34	1,00	8,35	—
10-3/4	55.50	273,05	82,59	12,57	247,90	244,48 <sup>e</sup>	80,75	9,43	—	12,25	-0,09	7,17	—
10-3/4	55.50	273,05	82,59	12,57	247,90	243,94	80,75	9,43	—	12,25	-0,09	7,17	—
10-3/4	60.70	273,05	90,33	13,84	245,40	241,40	88,47	8,53	—	11,07	—	5,90	—
10-3/4	65.70	273,05	97,77	15,11	242,80	238,86	96,12	7,62	—	9,98	—	—	—
10-3/4	73.20	273,05	108,93	17,07	238,90	234,95	107,76	—	—	—	—	—	—
10-3/4	79.20	273,05	117,86	18,64	235,80	231,80	116,95	—	—	—	—	—	—
10-3/4	85.30	273,05	126,94	20,24	232,60	228,60	126,19	—	—	—	—	—	—

See notes at end of table.

Table C.24 (continued)

Labels <sup>a</sup>		Outside diameter	Nominal linear mass T&C <sup>b, c</sup>	Wall thickness	Inside diameter	Drift diameter	Calculated mass <sup>c</sup>						
							Plain end	$e_m$ , mass gain or loss due to end finishing <sup>d</sup>					
1	2	D mm	kg/m	t mm	d mm	mm		$w_{pe}$ kg/m	kg		kg		kg
							Round thread		Buttress thread		Extreme-line		
1	2	3	4	5	6	7	8	Short	Long	Reg. OD	SCC	Standard	Optional
1	2	3	4	5	6	7	8	9	10	11	12	13	14
11-3/4	42.00	298,45	62,50	8,46	281,50	279,40 <sup>e</sup>	62,56	13,43	—	—	—	—	—
11-3/4	42.00	298,45	62,50	8,46	281,50	277,50	62,56	13,43	—	—	—	—	—
11-3/4	47.00	298,45	69,94	9,52	279,41	275,44	67,83	12,52	—	16,24	—	—	—
11-3/4	54.00	298,45	80,36	11,05	276,40	272,39	78,32	11,34	—	14,70	—	—	—
11-3/4	60.00	298,45	89,29	12,42	273,60	269,88 <sup>e</sup>	87,61	10,25	—	13,43	—	—	—
11-3/4	60.00	298,45	89,29	12,42	273,60	269,65	87,61	10,25	—	13,43	—	—	—
11-3/4	65.00	298,45	96,73	13,56	271,30	269,88 <sup>e</sup>	95,27	—	—	—	—	—	—
11-3/4	65.00	298,45	96,73	13,56	271,30	267,36	95,27	—	—	—	—	—	—
11-3/4	71.00	298,45	105,66	14,78	268,90	264,92	103,40	—	—	—	—	—	—
13-3/8	48.00	339,72	71,43	8,38	322,96	318,99	68,48	15,06	—	—	—	—	—
13-3/8	54.50	339,72	81,10	9,65	320,42	316,45	78,55	13,97	—	18,23	—	—	—
13-3/8	61.00	339,72	90,78	10,92	317,88	313,91	88,55	12,88	—	16,69	—	—	—
13-3/8	68.00	339,72	101,19	12,19	315,34	311,37	98,46	11,70	—	15,24	—	—	—
13-3/8	72.00	339,72	107,15	13,06	313,60	311,15 <sup>e</sup>	105,21	10,98	—	14,33	—	—	—
13-3/8	72.00	339,72	107,15	13,06	313,60	309,63	105,21	10,98	—	14,33	—	—	—
16	65.00	406,40	96,73	9,53	387,40	382,57	96,73	19,32	—	—	—	—	—
16	75.00	406,40	111,61	11,13	384,10	379,37	108,49	17,33	—	20,68	—	—	—
16	84.00	406,40	125,01	12,57	381,30	376,48	122,09	15,51	—	17,96	—	—	—
16	109.00	406,40	162,21	16,66	373,10	368,30	160,13	—	—	—	—	—	—
18-5/8	87.50	473,08	130,21	11,05	450,98	446,22	125,91	33,38	—	39,19	—	—	—
20	94.00	508,00	139,89	11,13	485,70	480,97	136,38	21,32	27,76	24,86	—	—	—
20	106.50	508,00	158,49	12,70	482,60	477,82	155,13	18,87	24,86	21,95	—	—	—
20	133.00	508,00	197,93	16,13	475,70	470,97	195,66	13,61	18,42	15,97	—	—	—

See also Figures D.1, D.2, D.3 and D.8.

<sup>a</sup> Labels are for information and assistance in ordering.

<sup>b</sup> Nominal linear masses, threaded and coupled (Col. 4) are shown for information only.

<sup>c</sup> The densities of martensitic chromium steels (L80 Types 9Cr and 13Cr) are less than those of carbon steels. The masses shown are therefore not accurate for martensitic chromium steels. A mass correction factor of 0,989 may be used.

<sup>d</sup> Mass gain or loss due to end finishing. See 8.5.

<sup>e</sup> Drift diameter for most common bit size. This drift diameter shall be specified on the purchase agreement and marked on the pipe. See 8.10 for drift requirements.

**Table C.25 — Dimensions and masses for standard tubing and for tubing threaded with API non-upset, external upset and integral joint tubing connections**

Labels <sup>a</sup>				Outside dia.	Nominal linear masses <sup>b, c</sup>			Wall thickness	Inside dia.	Calculated mass <sup>c</sup>				
										Plain end	$e_m$ , mass gain or loss due to end finishing <sup>d</sup>			
1	2			<i>D</i> mm	Non-upset T&C kg/m	Ext upset T&C kg/m	Integral joint kg/m	<i>t</i> mm	<i>d</i> mm		$w_{pe}$ kg/m	Non-upset	External upset <sup>e</sup>	
	NU T&C	EU T&C	IJ							Regular			Special clear	
1	2	3	4	5	6	7	8	9	10	11	12	13	14	15
1.050	1.14	1.20	—	26,67	1,70	1,79	—	2,87	20,93	1,68	0,09	0,64	—	—
1.050	1.48	1.54	—	26,67	2,20	2,29	—	3,91	18,85	2,19	—	0,60	—	—
1.315	1.70	1.80	1.72	33,40	2,53	2,68	2,56	3,38	26,64	2,50	0,18	0,64	—	0,09
1.315	2.19	2.24	—	33,40	3,26	3,33	—	4,55	24,30	3,24	—	0,61	—	—
1.660	2.09	—	2.10	42,16	—	—	3,13	3,18	35,80	3,06	—	—	—	0,09
1.660	2.30	2.40	2.33	42,16	3,42	3,57	3,47	3,56	35,04	3,39	0,36	0,73	—	0,09
1.660	3.03	3.07	—	42,16	4,51	4,57	—	4,85	32,46	4,46	—	0,68	—	—
1.900	2.40	—	2.40	48,26	—	—	3,57	3,18	41,90	3,54	—	—	—	0,09
1.900	2.75	2.90	2.76	48,26	4,09	4,32	4,11	3,68	40,90	4,05	0,27	0,91	—	0,09
1.900	3.65	3.73	—	48,26	5,43	5,55	—	5,08	38,10	5,41	—	0,92	—	—
1.900	4.42	—	—	48,26	6,58	—	—	6,35	35,56	6,56	—	—	—	—
1.900	5.15	—	—	48,26	7,66	—	—	7,62	33,02	7,64	—	—	—	—
2.063	3.24	—	3.25	52,40	—	—	4,84	3,96	44,48	4,73	—	—	—	0,09
2.063	4.50	—	—	52,40	—	—	—	5,72	40,96	6,58	—	—	—	—
2-3/8	4.00	—	—	60,32	5,95	—	—	4,24	51,84	5,86	0,73	—	—	—
2-3/8	4.60	4.70	—	60,32	6,85	6,99	—	4,83	50,66	6,61	0,73	1,81	1,34	—
2-3/8	5.80	5.95	—	60,32	8,63	8,85	—	6,45	47,42	8,57	0,64	1,63	1,16	—
2-3/8	6.60	—	—	60,32	9,82	—	—	7,49	45,34	9,76	—	—	—	—
2-3/8	7.35	7.45	—	60,32	10,94	11,09	—	8,53	43,26	10,89	—	—	—	—
2-7/8	6.40	6.50	—	73,02	9,52	9,67	—	5,51	62,00	9,17	1,45	2,54	1,71	—
2-7/8	7.80	7.90	—	73,02	11,61	11,76	—	7,01	59,00	11,41	1,27	2,63	1,78	—
2-7/8	8.60	8.70	—	73,02	12,80	12,95	—	7,82	57,38	12,57	1,18	2,27	1,43	—
2-7/8	9.35	9.45	—	73,02	13,91	14,06	—	8,64	54,74	13,72	—	—	—	—
2-7/8	10.50	—	—	73,02	15,63	—	—	9,96	53,10	15,49	—	—	—	—
2-7/8	11.50	—	—	73,02	17,11	—	—	11,18	50,66	17,05	—	—	—	—
3-1/2	7.70	—	—	88,90	11,46	—	—	5,49	77,92	11,29	2,45	—	—	—
3-1/2	9.20	9.30	—	88,90	13,69	13,84	—	6,45	76,00	13,12	2,27	4,17	2,45	—
3-1/2	10.20	—	—	88,90	15,18	—	—	7,34	74,22	14,76	2,18	—	—	—
3-1/2	12.70	12.95	—	88,90	18,90	19,27	—	9,52	69,86	18,64	1,81	3,72	2,00	—
3-1/2	14.30	—	—	88,90	21,28	—	—	10,92	67,06	21,00	—	—	—	—
3-1/2	15.50	—	—	88,90	23,07	—	—	12,09	64,72	22,90	—	—	—	—
3-1/2	17.00	—	—	88,90	25,30	—	—	13,46	61,98	25,04	—	—	—	—
4	9.50	—	—	101,60	14,14	—	—	5,74	90,12	13,57	2,81	—	—	—
4	10.70	11.00	—	101,60	—	16,37	—	6,65	88,30	15,57	—	4,81	—	—
4	13.20	—	—	101,60	19,64	—	—	8,38	84,84	19,27	—	—	—	—
4	16.10	—	—	101,60	23,96	—	—	10,54	80,52	23,67	—	—	—	—
4	18.90	—	—	101,60	28,13	—	—	12,70	76,20	27,84	—	—	—	—
4	22.20	—	—	101,60	33,04	—	—	15,49	70,62	32,89	—	—	—	—
4-1/2	12.60	12.75	—	114,30	18,75	18,97	—	6,88	100,54	18,23	2,72	—	—	—
4-1/2	15.20	—	—	114,30	22,62	—	—	8,56	97,18	22,32	—	—	—	—
4-1/2	17.00	—	—	114,30	25,30	—	—	9,65	95,00	24,90	—	—	—	—
4-1/2	18.90	—	—	114,30	28,13	—	—	10,92	92,46	27,84	—	—	—	—
4-1/2	21.50	—	—	114,30	32,00	—	—	12,70	88,90	31,82	—	—	—	—
4-1/2	23.70	—	—	114,30	35,27	—	—	14,22	85,86	35,10	—	—	—	—
4-1/2	26.10	—	—	114,30	38,84	—	—	16,00	82,30	38,79	—	—	—	—

See also Figures D.4, D.5 and D.7.

<sup>a</sup> Labels are for information and assistance in ordering.

<sup>b</sup> Nominal linear masses, threaded and coupled (Col. 6,7 and 8) are shown for information only.

<sup>c</sup> The densities of martensitic chromium (L80 Types 9Cr and 13Cr) are different from carbon steels. The masses shown are therefore not accurate for martensitic chromium steels. A mass correction factor of 0,989 may be used.

<sup>d</sup> Mass gain or loss due to end finishing. See 8.5.

<sup>e</sup> The length of the upset may alter the mass gain or loss due to end finishing.

**Table C.26 — API extreme-line casing upset end dimensions**

Labels		Outside diameter <i>D</i>  mm	Nominal linear mass upset and threaded  kg/m	Finished pin-and-box dimensions <sup>a</sup>								
				Pin-and-box outside diameter (turned) +0,51 -0,25  mm		Pin inside diameter (bored) ± 0,38  mm	Box inside diameter (bored) +0,76 0  mm	Pin-and-box made-up (power-tight) <sup>b</sup>  mm			Drift dia. for finished upset member  mm	Drift diameter for full length drifting min.  mm
				Standard  <i>M</i>	Optional  <i>M</i>	Standard and optional  <i>B</i>	Standard and optional  <i>D</i>	Outside diameter, +0,51 mm -0,25 mm		Inside diameter, +0,25 mm -0,13 mm	Standard and optional	Standard and optional
1	2							Standard <sup>c</sup>	Optional <sup>c</sup>	Standard and optional		
1	2	3	4	5	6	7	8	9	10	11	12	13
5	15.00	127,00	22,32	136,14	—	106,88	107,57	136,14	—	106,63	106,25	105,44
5	18.00	127,00	26,79	136,14	—	106,88	107,57	136,14	—	106,63	106,25	105,44
5-1/2	15.50	139,70	23,07	148,84	146,81	120,55	121,23	148,84	146,81	120,29	119,91	118,19
5-1/2	17.00	139,70	25,30	148,84	146,81	119,66	120,35	148,84	146,81	119,41	119,02	118,19
5-1/2	20.00	139,70	29,76	148,84	146,81	119,66	120,35	148,84	146,81	119,41	119,02	118,19
5-1/2	23.00	139,70	34,23	148,84	146,81	117,32	118,03	148,84	146,81	117,09	116,71	115,44
6-5/8	24.00	168,28	35,72	177,80	176,02	147,12	147,78	177,80	176,02	146,84	146,46	145,54
6-5/8	28.00	168,28	41,67	177,80	176,02	145,82	146,51	177,80	176,02	145,57	145,19	143,92
6-5/8	32.00	168,28	47,62	177,80	176,02	142,85	143,56	177,80	176,02	142,62	142,24	140,97
7	23.00	177,80	34,23	187,71	185,67	157,02	157,68	187,71	185,67	156,74	156,36	156,24
7	26.00	177,80	38,69	187,71	185,67	157,02	157,68	187,71	185,67	156,74	156,36	156,24
7	29.00	177,80	43,16	187,71	185,67	155,80	156,46	187,71	185,67	155,52	155,14	153,90
7	32.00	177,80	47,62	187,71	185,67	153,47	154,15	187,71	185,67	153,21	152,83	151,61
7	35.00	177,80	52,09	191,26	187,71	151,10	151,82	191,26	187,71	150,88	150,50	149,33
7	38.00	177,80	56,55	191,26	187,71	149,07	149,78	191,26	187,71	148,84	148,46	147,19
7-5/8	26.40	193,68	39,29	203,45	201,17	172,26	172,90	203,45	201,17	171,96	171,58	171,45
7-5/8	29.70	193,68	44,20	203,45	201,17	172,26	172,90	203,45	201,17	171,96	171,58	171,45
7-5/8	33.70	193,68	50,15	203,45	201,17	170,59	171,25	203,45	201,17	170,31	169,93	168,66
7-5/8	39.00	193,68	58,04	203,45	201,17	167,00	167,69	203,45	201,17	166,75	166,37	165,10
8-5/8	32.00	219,08	47,62	231,65	229,36	196,52	197,15	231,65	229,36	196,22	195,83	195,58
8-5/8	36.00	219,08	53,57	231,65	229,36	196,52	197,16	231,65	229,36	196,22	195,83	195,58
8-5/8	40.00	219,08	59,53	231,65	229,36	194,92	195,58	231,65	229,36	194,64	194,26	193,04
8-5/8	44.00	219,08	65,48	231,65	229,36	192,40	193,09	231,65	229,36	192,15	191,77	190,50
8-5/8	49.00	219,08	72,92	231,65	229,36	189,48	190,20	231,65	229,36	189,26	188,87	187,60
9-5/8	40.00	244,48	59,53	256,54	254,51	220,40	221,03	256,54	254,51	220,09	219,71	218,41
9-5/8	43.50	244,48	64,73	256,54	254,51	220,40	221,03	256,54	254,51	220,09	219,71	218,41
9-5/8	47.00	244,48	69,94	256,54	254,51	219,28	219,91	256,54	254,51	218,97	218,59	216,54
9-5/8	53.50	244,48	79,62	256,54	254,51	215,52	216,20	256,54	254,51	215,27	214,88	212,83
10%	45.50	273,05	67,71	291,08	—	249,66	250,29	291,08	—	249,40	249,02	248,77
10%	51.00	273,05	75,90	291,08	—	247,12	247,75	291,08	—	246,86	246,48	246,23
10%	55.50	273,05	82,59	291,08	—	244,83	245,47	291,08	—	244,58	244,20	243,94
10%	60.70	273,05	90,33	291,08	—	242,29	242,93	291,08	—	242,04	241,66	241,40

See also Table C.24 and Figure D.8.

<sup>a</sup> Due to the nature of extreme-line casing, certain dimensional symbols and nomenclature differ from those for similar details for other pipe covered by this International Standard.

<sup>b</sup> Shown for reference.

<sup>c</sup> Made-up joint *D* is the same as the outside diameter dimension *M*.

**Table C.27 — External upset tubing dimensions for API connections, Groups 1, 2, and 3**

Labels <sup>a</sup>		Outside diameter <i>D</i>	Nominal linear mass threaded and coupled <sup>b</sup>	Upset			
				Outside diameter <sup>c</sup> <i>D</i> <sub>4</sub>	Length from end of pipe to start of taper <sup>d, e</sup> <i>L</i> <sub>eu</sub>	Length from end of pipe to end of taper <sup>e</sup> <i>L</i> <sub>a</sub>	Length from end of pipe to start of pipe body <sup>e</sup> <i>L</i> <sub>b</sub>
1	2	mm	kg/m	mm +1,59 0	mm +0 -25,4	mm	mm max.
1	2	3	4	5	6	7	8
1.050	1.20	26,67	1,79	33,40	60,32	—	—
1.050	1.54	26,67	2,29	33,40	60,32	—	—
1.315	1.80	33,40	2,68	37,31	63,50	—	—
1.315	2.24	33,40	3,33	37,31	63,50	—	—
1.660	2.40	42,16	3,57	46,02	66,68	—	—
1.660	3.07	42,16	4,57	46,02	66,68	—	—
1.900	2.90	48,26	4,32	53,19	68,26	—	—
1.900	3.73	48,26	5,55	53,19	68,26	—	—
2-3/8	4.70	60,32	6,99	65,89	101,60	152,40	254,00
2-3/8	5.95	60,32	8,85	65,89	101,60	152,40	254,00
2-3/8	7.45	60,32	11,09	65,89	101,60	152,40	254,00
2-7/8	6.50	73,02	9,67	78,59	107,95	158,75	260,35
2-7/8	7.90	73,02	11,76	78,59	107,95	158,75	260,35
2-7/8	8.70	73,02	12,95	78,59	107,95	158,75	260,35
2-7/8	9.45	73,02	14,06	78,59	107,95	158,75	260,35
3-1/2	9.30	88,90	13,84	95,25	114,30	165,10	266,70
3-1/2	12.95	88,90	19,27	95,25	114,30	165,10	266,70
4	11.00	101,60	16,37	107,95	114,30	165,10	266,70
4-1/2	12.75	114,30	18,97	120,65	120,65	171,45	273,05

See also Figures D.5 and D.6.

<sup>a</sup> Labels are for information and assistance in ordering.

<sup>b</sup> The densities of martensitic chromium steels (L80 9Cr and 13Cr) are different from carbon steels. The masses shown are therefore not accurate for chromium steels. A mass correction factor of 0,989 may be used.

<sup>c</sup> The minimum outside diameter of upset *D*<sub>4</sub> is limited by the minimum length of full-crest threads. See API Spec 5B.

<sup>d</sup> For pup joints only, the length tolerance on *L*<sub>eu</sub> is + 101,6 mm to - 25,4 mm. The length on *L*<sub>b</sub> may be 101,6 mm longer than specified.

<sup>e</sup> For extended-length upsets on external upset tubing, add 25,4 mm to the dimensions in columns 6, 7 and 8.

**Table C.28 — Integral joint tubing dimensions for API connections, Groups 1 and 2**

Labels		Outside dia. <i>D</i>	Nominal linear mass <sup>a</sup> T&C	Upset dimensions								
				Pin				Box				
				Outside dia. <sup>b</sup> <i>D</i> <sub>4</sub>	Inside dia. <sup>c</sup> <i>d</i> <sub>iu</sub>	Length <i>L</i> <sub>iu</sub>	Length of taper <i>m</i> <sub>iu</sub>	Outside diameter <i>W</i> <sub>b</sub>	Length <i>L</i> <sub>eu</sub>	Length of taper <i>m</i> <sub>eu</sub>	Diameter of recess <i>Q</i>	Width of face <i>b</i>
mm	mm	mm	mm	mm	mm	mm	mm	mm	mm			
1	2			+1,59 0	+0,38 0	mm min.	mm min.	+0,13 -0,64	mm min.	mm	mm	mm min.
1	2	3	4	5	6	7	8	9	10	11	12	13
1.315	1.72	33,40	2,56	—	24,64	34,92	6,35	39,37	44,45	25,40	35,00	0,79
1.660	2.10	42,16	3,13	—	33,05	38,10	6,35	47,75	47,62	25,40	43,76	0,79
1.660	2.33	42,16	3,47	—	33,05	38,10	6,35	47,75	47,62	25,40	43,76	0,79
1.900	2.40	48,26	3,57	—	38,89	41,28	6,35	53,59	50,80	25,40	49,86	0,79
1.900	2.76	48,26	4,11	—	38,89	41,28	6,35	53,59	50,80	25,40	49,86	0,79
2.063	3.25	52,40	4,84	53,19	42,47	42,86	6,35	59,06	53,98	25,40	54,76	0,79

See also Figure D.7.

- <sup>a</sup> Nominal linear masses, upset and threaded, are shown for information only.
- <sup>b</sup> The minimum outside diameter *D*<sub>4</sub> is limited by the minimum length of full-crest threads. See API Spec 5B.
- <sup>c</sup> The minimum diameter *d*<sub>iu</sub> is limited by the drift test.

**Table C.29 — Plain-end liners — Dimensions and masses for Grade J55**

Labels		Outside diameter <i>D</i>	Plain-end linear mass	Wall thickness <i>t</i>	Inside diameter <i>d</i>
1	2	mm	kg/m	mm	mm
1	2	3	4	5	6
3-1/2	9.92	88,90	14,76	7,34	74,22
4	11.35	101,60	16,89	7,26	87,08
4-1/2	13.05	114,30	19,44	7,37	99,56
5	17.95	127,00	26,70	9,19	108,62
5-1/2	19.83	139,70	29,52	9,17	121,36
6-5/8	27.67	168,28	41,18	10,59	147,10

**Table C.30 — Range lengths**

Dimensions in metres

	Range 1	Range 2	Range 3
<b>CASING AND LINERS</b>			
Total range length, inclusive	4,88 to 7,62	7,62 to 10,36	10,36 to 14,63
Range length for 95 % or more of carload: <sup>a</sup>			
Permissible variation, max.	1,83	1,52	1,83
Permissible length, min.	5,49	8,53	10,97
<b>THREADED AND COUPLED TUBING AND CASING USED AS TUBING</b>			
Total range length, inclusive	6,10 to 7,32 <sup>b</sup>	8,53 to 9,75 <sup>c</sup>	11,58 to 12,80 <sup>d</sup>
Range length for 100 % of carload: <sup>a</sup>			
Permissible variation, max.	0,61	0,61	0,61
<b>INTEGRAL JOINT TUBING (including IJ/UF and IJ/SF)</b>			
Total range length, inclusive	6,10 to 7,92 <sup>b</sup>	8,53 to 10,36	11,58 to 13,72
Range length for 100 % of carload: <sup>a</sup>			
Permissible variation, max.	0,61	0,61	0,61
<b>PUP JOINTS</b>	Lengths 0,61; 0,91; 1,22; 1,83; 2,44; 3,05 and 3,66 <sup>e</sup>		
	Tolerance ± 0,076		
<sup>a</sup> Carload tolerances shall not apply to order items of less than 18 144 kg of pipe. For any carload of 18 144 kg or more of pipe that is shipped to the final destination without transfer or removal from the car, the tolerance shall apply to each car. For any order item consisting of more than 18 144 kg of pipe that is shipped from the manufacturer's facility by rail, but not to the final destination, the carload tolerance shall apply to the overall quantity of pipe shipped on the order item, but not to the individual carloads. <sup>b</sup> By agreement between purchaser and manufacturer, the maximum length may be increased to 8,53 m. <sup>c</sup> By agreement between purchaser and manufacturer, the maximum length may be increased to 10,36 m. <sup>d</sup> By agreement between purchaser and manufacturer, the maximum length may be increased to 13,72 m. <sup>e</sup> 0,61 m pup joints may be furnished up to 0,91 m long by agreement between purchaser and manufacturer, and lengths other than those listed may be furnished by agreement between purchaser and manufacturer.			

**Table C.31 — Standard drift size**

Dimensions in millimetres

Product and Label 1	Standard drift mandrel size	
	min.	
	Length	Diameter
Casing <sup>a</sup> and liners		
< 9-5/8	152	$d - 3,18$
$\geq 9-5/8$ to $\leq 13-3/8$	305	$d - 3,97$
> 13-3/8	305	$d - 4,76$
Tubing <sup>b</sup>		
$\leq 2-7/8$	1 067	$d - 2,38$
> 2-7/8	1 067	$d - 3,18$
<sup>a</sup> The minimum diameter of the drift mandrel for extreme-line casing shall be as shown in cols. 12 and 13, Table C.26. <sup>b</sup> Integral-joint tubing shall be tested before upsetting with a drift mandrel as shown, and shall also be drift tested at the pin end, after upsetting, with a cylindrical drift mandrel 1 067 mm in length and $d_{iu} - 0,38$ mm in diameter (see Table C.28, Col. 6 for $d_{iu}$ ).		

**Table C.32 — Alternative drift size**

Labels		Outside diameter <i>D</i> mm	Product linear mass kg/m	Alternative drift mandrel size mm min.	
1	2			Length	Diameter
1	2	3	4	5	6
7	23.00	177,80	34,23	152	158,75
7	32.00	177,80	47,62	152	152,40
7-3/4	46.10	196,85	68,60	152	165,10
8-5/8	32.00	219,08	47,62	152	200,02
8-5/8	40.00	219,08	59,53	152	193,68
9-5/8	40.00	244,48	59,53	305	222,25
9-5/8	53.50	244,48	79,62	305	215,90
9-5/8	58.40	244,48	86,91	305	212,72
10-3/4	45.50	273,05	67,71	305	250,82
10-3/4	55.50	273,05	82,59	305	244,48
11-3/4	42.00	298,45	62,50	305	279,40
11-3/4	60.00	298,45	89,29	305	269,88
11-3/4	65.00	298,45	96,73	305	269,88
13-3/8	72.00	339,72	107,15	305	311,15

**Table C.33 — Maximum permissible depth of linear imperfections**

Grade	Depth as % of specified wall thickness	
	External	Internal
H40 – J55 – K55 – M65 – N80 Type 1 – N80Q L80 – C95 – P110 to A.10 (SR16)	12,5 %	12,5 %
C90 – T95 – P110 – Q125	5 %	5 %
P110 to A.10 (SR16) and A.3 (SR2)	5 %	5 %



**Table C.34 — Upset products — Maximum permissible depth of imperfections**

	Surface	Depth	Measurement notes
<b>A Extreme-line casing, integral joint and external upset tubing (see Figures D.5, D.7 and D.8)</b>			
A.1	All surfaces of upset and upset run-out interval, except as stated below	12,5 % $t$	Percentage of specified pipe body wall thickness $t$ ; for non-linear imperfections; for all groups of pipe
		12,5 % $t$	Percentage of specified pipe body wall thickness $t$ ; for linear imperfections; for Group 1 and Group 2 (except C90 and T95) pipe
		5 % $t$	Percentage of specified pipe body wall thickness $t$ ; for linear imperfections; for Group 3, Group 4 and Grades C90 and T95 pipe
A.2 The minimum wall thickness in the upset run-out interval, and the maximum combined effect of coincident internal and external imperfections in all areas, shall not total less than 87,5 % of the specified wall thickness.			
<b>B Extreme-line casing (see Figure D.8)</b>			
B.1	Box end external surface	0,25 mm	For Label 1: 7-5/8 and smaller sizes. From end of pipe to a plane 120,6 mm from the end.
		0,25 mm	For Label 1: Larger than 7-5/8. From end of pipe to a plane 165,1 mm from the end.
B.2	Pin end internal surface	0,38 mm	From end of pipe to plane of external shoulder (bored)
B.3 All machined surfaces of the box shall be free of seams, laps and cracks. The pin-and-box shall be free of any imperfections which break the continuity of the threads or seals.			
<b>C Integral joint tubing (see Figure D.7)</b>			
C.1	Box end external surface	0,25 mm	From end of pipe to a plane at a distance equal to the specified minimum dimension $L_{eu}$ (Figure D.7) from end of pipe.
C.2	Pin end internal surface	0,38 mm	From end of pipe to a plane at a distance equal to the specified minimum dimension $L_{iu}$ (Figure D.7) from end of pipe.
			For Grades C90 and T95, the maximum permissible depth for linear imperfections shall be 5 % of the specified pipe body wall thickness.
C.3 Upset underfill in the upset run-out intervals shall not be considered a defect unless the remaining wall thickness (at the upset underfill) is less than 87,5 % of the specified pipe body wall thickness.			

**Table C.35 — API round-thread casing coupling — Dimensions, tolerances and masses**

Label 1	Size <sup>a</sup>	Outside diameter $W$ <sup>b, c</sup>	Minimum length		Diameter of recess $Q$ <sup>d</sup>	Width of bearing face $b$	Mass	
	Outside diameter $D$		mm				kg	
	$D$		Short $N_L$	Long $N_L$			Short	Long
	mm	mm			mm	mm		
1	2	3	4	5	6	7	8	9
4-1/2	114,30	127,00	158,75	177,80	116,68	3,97	3,62	4,15
5	127,00	141,30	165,10	196,85	129,38	4,76	4,66	5,75
5-1/2	139,70	153,67	171,45	203,20	142,08	3,18	5,23	6,42
6-5/8	168,28	187,71	184,15	222,25	170,66	6,35	9,12	11,34
7	177,80	194,46	184,15	228,60	180,18	4,76	8,39	10,83
7-5/8	193,70	215,90	190,50	234,95	197,64	5,56	12,30	15,63
8-5/8	219,08	244,48	196,85	254,00	223,04	6,35	16,23	21,67
9-5/8	244,48	269,88	196,85	266,70	248,44	6,35	18,03	25,45
10-3/4	273,05	298,45	203,20	—	277,02	6,35	20,78	—
11-3/4	298,45	323,85	203,20	—	302,42	6,35	22,64	—
13-3/8	339,72	365,12	203,20	—	343,69	5,56	25,66	—
16	406,40	431,80	228,60	—	411,96	5,56	34,91	—
18-5/8	473,08	508,00	228,60	—	478,63	5,56	54,01	—
20	508,00	533,40	228,60	292,10	513,56	5,56	43,42	57,04

See also Figures D.1 and D.2.

<sup>a</sup> The size designation for the coupling is the same as the size designation for the pipe on which the coupling is used.

<sup>b</sup> Groups 1, 2 and 3 — Tolerance on outside diameter  $W$ ,  $\pm 1\%$  but not greater than  $\pm 3,18$  mm.

<sup>c</sup> Group 4 — Tolerance on outside diameter  $W$ ,  $\pm 1\%$  but not greater than  $\begin{matrix} +3,18 \\ -1,59 \end{matrix}$  mm.

<sup>d</sup> Tolerance on diameter of recess,  $Q$ , for all groups is  $\begin{matrix} +0,79 \\ 0 \end{matrix}$  mm.

**Table C.36 — API buttress thread casing coupling — Dimensions, tolerances and masses**

Label 1	Size <sup>a</sup>	Outside diameter		Minimum length $N_L$ mm	Diameter of counterbore $Q$ mm	Width of bearing face $b$ mm	Mass kg	
	Outside diameter $D$ mm	Regular $W$ <sup>b, c</sup> mm	Special clearance <sup>d</sup> $W_C$ mm				Regular	Special clearance
1	2	3	4	5	6	7	8	9
4-1/2	114,30	127,00	123,82	225,42	117,86	3,18	4,55	3,48
5	127,00	141,30	136,52	231,78	130,56	3,97	5,85	4,00
5-1/2	139,70	153,67	149,22	234,95	143,26	3,97	6,36	4,47
6-5/8	168,28	187,71	177,80	244,48	171,83	6,35	11,01	5,65
7	177,80	194,46	187,32	254,00	181,36	5,56	10,54	6,28
7-5/8	193,68	215,90	206,38	263,52	197,23	7,94	15,82	9,29
8-5/8	219,08	244,48	231,78	269,88	222,63	9,52	20,86	10,80
9-5/8	244,48	269,88	257,18	269,88	248,03	9,52	23,16	12,02
10-3/4	273,05	298,45	285,75	269,88	276,61	9,52	25,74	13,39
11-3/4	298,45	323,85	—	269,88	302,01	9,52	28,03	—
13-3/8	339,72	365,12	—	269,88	343,28	9,52	31,77	—
16	406,40	431,80	—	269,88	410,31	9,52	40,28	—
18-5/8	473,08	508,00	—	269,88	476,99	9,52	62,68	—
20	508,00	533,40	—	269,88	511,91	9,52	50,10	—

See also Figure D.3.

<sup>a</sup> The size designation for the coupling is the same as the size designation for the pipe on which the coupling is used.

<sup>b</sup> Groups 1, 2 and 3 : Tolerance on outside diameter  $W$ ,  $\pm 1\%$  but not greater than  $\pm 3,18$  mm.

<sup>c</sup> Group 4 : Tolerance on outside diameter  $W$ ,  $\pm 1\%$  but not greater than  $\begin{matrix} +3,18 \\ -1,59 \end{matrix}$  mm.

<sup>d</sup> Groups 1, 2 and 3 — Tolerance on outside diameter  $W_C$ ,  $\begin{matrix} +0,79 \\ -0,40 \end{matrix}$  mm.

**Table C.37 — API non-upset tubing coupling — Dimensions, tolerances and masses**

Label 1	Size <sup>a</sup>	Outside diameter $W$ <sup>b</sup> mm	Minimum length $N_L$ mm	Diameter of recess $Q$ mm	Width of bearing face $b$ mm	Maximum bearing face diameter, special bevel $B_f$ mm	Mass kg
	Outside diameter $D$ mm						
1	2	3	4	5	6	7	8
1.050	26,67	33,35	80,96	28,27	1,59	30,00	0,23
1.315	33,40	42,16	82,55	35,00	2,38	37,80	0,38
1.660	42,16	52,17	88,90	43,76	3,18	47,17	0,59
1.900	48,26	55,88	95,25	49,86	1,59	52,07	0,56
2-3/8	60,32	73,02	107,95	61,93	4,76	66,68	1,28
2-7/8	73,02	88,90	130,18	74,63	4,76	80,98	2,34
3-1/2	88,90	107,95	142,88	90,50	4,76	98,42	3,71
4	101,60	120,65	146,05	103,20	4,76	111,12	4,35
4-1/2	114,30	132,08	155,58	115,90	4,76	123,19	4,89

See also Figure D.4.

<sup>a</sup> The size designation for the coupling is the same as the size designation for the pipe on which the coupling is used.

<sup>b</sup> Tolerance on outside diameter  $W$ ,  $\pm 1\%$ .

**Table C.38 — API external-upset tubing coupling — Dimensions, tolerances and masses**

Label 1	Size <sup>a</sup>	Outside diameter		Minimum length	Diameter of recess	Width of bearing face, regular	Maximum bearing face diameter <i>B<sub>f</sub></i>		Mass kg	
	Outside diameter <i>D</i> mm	Regular & special bevel <i>W<sup>b</sup></i> mm	Special clearance <i>W<sub>C</sub><sup>c</sup></i> mm				Special bevel mm	Special clearance mm	Regular	Special clearance
1	2	3	4	5	6	7	8	9	10	11
1.050	26,67	42,16	—	82,55	35,00	2,38	37,80	—	0,38	—
1.315	33,40	48,26	—	88,90	38,89	2,38	42,77	—	0,57	—
1.660	42,16	55,88	—	95,25	47,63	3,18	50,95	—	0,68	—
1.900	48,26	63,50	—	98,42	54,76	3,18	58,34	—	0,84	—
2-3/8	60,32	77,80	73,91	123,82	67,46	3,97	71,83	69,90	1,55	1,07
2-7/8	73,02	93,17	87,88	133,35	80,16	5,56	85,88	83,24	2,40	1,55
3-1/2	88,90	114,30	106,17	146,05	96,85	6,35	104,78	100,71	4,10	2,38
4	101,60	127,00	—	152,40	109,55	6,35	117,48	—	4,82	—
4-1/2	114,30	141,30	—	158,75	122,25	6,35	130,96	—	6,05	—

See also Figure D.5.

<sup>a</sup> The size designation for the coupling is the same as the size designation for the pipe on which the coupling is used.

<sup>b</sup> Tolerance on outside diameter *W*, ± 1 %.

<sup>c</sup> Tolerance on outside diameter *W<sub>C</sub>*, ± 0,38 mm.

**Table C.39 — Permissible depth of external imperfections on coupling**

Coupling for Label 1		Group 1 Group 2 (except C90 and T95) Group 3		Group 2 (C90 and T95) Group 4
		Pits and round-bottom gouges	Grip marks and sharp-bottom gouges	Pits, round-bottom gouges, sharp-bottom gouges, grip marks
1	2	3	4	5
Tubing	< 3-1/2	0,76	0,64	0,76
	≥ 3-1/2 to ≤ 4-1/2	1,14	0,76	0,89
Casing <sup>a</sup>	< 6-5/8	0,89	0,76	0,76
	≥ 6-5/8 to ≤ 7-5/8	1,14	1,02	0,89
	> 7-5/8	1,52	1,02	0,89

<sup>a</sup> Includes casing used as tubing.

**Table C.40 — Frequency of tensile tests — Casing and tubing**

Group	Label 1	Maximum number of pieces in a lot	Number of tests	
			per lot	per heat
1	2	3	4	5
1	< 6-5/8	400 <sup>a, b</sup>	1	1
	≥ 6-5/8	200 <sup>a, b</sup>	1	1
2	≤ 4-1/2 – Grades M65, L80 Type 1, C95	200 <sup>a, b</sup>	2 <sup>c</sup>	1
	≤ 4-1/2 – Grades L80 9Cr, L80 13Cr	200 <sup>b, d</sup>	2 <sup>c</sup>	—
	≤ 4-1/2 – Grades C90, T95	200 <sup>b, d</sup>	1	—
	> 4-1/2 – Grades M65, L80 Type 1, C95	100 <sup>a, b</sup>	2 <sup>c</sup>	1
	> 4-1/2 – Grades L80 9Cr, L80 13Cr	100 <sup>b, d</sup>	2 <sup>c</sup>	—
	> 4-1/2 – Grades C90, T95	100 <sup>b, d</sup>	1	—
3	< 6 5/8	200 <sup>a, b</sup>	1	1
	≥ 6 5/8	100 <sup>a, b</sup>	1	1
4	All sizes	— <sup>d</sup>	3 <sup>c</sup>	—

For Groups 1, 2 and 3 multiple-length seamless pipe, a length shall be considered as all of the sections cut from a particular multiple length, provided the pipe receives no additional heat treatment after being cut into individual lengths.

NOTE Table includes casing used as tubing.

- <sup>a</sup> See 10.2.1.
- <sup>b</sup> See 10.4.2.
- <sup>c</sup> See 10.4.3.
- <sup>d</sup> See 10.2.2.

**Table C.41 — Frequency of tensile tests — Coupling stock and couplings**

Group	Source of coupling		Maximum number of pieces in a lot	Number of tests	
	Material	Condition when heat-treated		per lot	per heat
1	2	3	4	5	6
Groups 1 & 3	Coupling stock	Coupling stock for pipe ≤ Label 1: 4-1/2	200 <sup>a</sup>	1	1 <sup>b</sup>
		Coupling stock for pipe > Label 1: 4-1/2	100 <sup>a</sup>	1	1 <sup>b</sup>
		Coupling blank	400 <sup>c</sup>	1	—
	Hot forging	Coupling blank	400 <sup>c</sup>	1	—
Group 2 Grades L80 Type 1 and C95	Coupling stock	Coupling stock for pipe ≤ Label 1: 4-1/2	200 <sup>a</sup>	2 <sup>d</sup>	2 <sup>d</sup>
		Coupling stock for pipe > Label 1: 4-1/2	100 <sup>a</sup>	2 <sup>d</sup>	2 <sup>d</sup>
		Coupling blank	400 <sup>c</sup>	2	—
	Hot forging	Coupling blank	400 <sup>c</sup>	2	—
Group 2 Grades L80 9Cr and L80 13Cr	Coupling stock	Coupling stock for pipe ≤ Label 1: 4-1/2	200 <sup>d</sup>	2 <sup>d</sup>	—
		Coupling stock for pipe > Label 1: 4-1/2	100 <sup>d</sup>	2 <sup>d</sup>	—
		Coupling blank	400 <sup>c</sup>	2	—
	Hot forging	Coupling blank	400 <sup>c</sup>	2	—
Group 2 Grades C90 and T95	Coupling stock	Coupling stock for pipe Label 1: All sizes	1 <sup>b</sup>	1	—
		Coupling blank	Label 1: < 9-5/8: 50 <sup>c</sup> Label 1: ≥ 9-5/8: 30 <sup>c</sup>	1	—
	Hot forging	Coupling blank	Label 1: < 9-5/8: 50 <sup>c</sup> Label 1: ≥ 9-5/8: 30 <sup>c</sup>	1	—
Group 4	Coupling stock	Coupling stock for pipe Label 1: All sizes	1 <sup>b</sup>	1	—
		Coupling blank	Label 1: < 9-5/8: 50 <sup>c</sup> Label 1: ≥ 9-5/8: 30 <sup>c</sup>	1	—

<sup>a</sup> See 10.2.1.  
<sup>b</sup> Approximately 50 % from each end.  
<sup>c</sup> See 10.2.3.  
<sup>d</sup> See 10.2.2.

**Table C.42 — Frequency of tensile testing — Pup joints and accessories**

Group	Material <sup>a</sup>		Maximum number of pieces in a lot	Number of tests	
				per lot	per heat
1	2	3	4	5	6
Groups 1 & 3	Group 1: Full-length standard tubing or casing from one or more heats		Label 1: < 6-5/8: 400 Label 1: ≥ 6-5/8: 200	1	1
	Group 3: Full-length standard tubing or casing from one or more heats		Label 1: < 6-5/8: 200 Label 1: ≥ 6-5/8: 100	1	1
	Thick-wall mechanical tube or bar stock from a single heat		Label 1: ≤ 4-1/2: 200 Label 1: > 4-1/2: 100	1	1
	Heat-treated in blanks or individual lengths or hot forgings	Batch heat treatment	100 pup joints or 400 accessories	1	—
Heat-treated in sequential loads or continuous heat treatment		In accordance with 10.2.3	1	—	
Group 2 Grades M65, L80 Type 1, C95	Full-length standard tubing or casing from one or more heats		Label 1: ≤ 4-1/2: 200 Label 1: > 4-1/2: 100	2 <sup>b</sup>	2 <sup>b</sup>
	Thick-wall mechanical tube or bar stock from a single heat		Label 1: ≤ 4-1/2: 200 Label 1: > 4-1/2: 100	2 <sup>b</sup>	2 <sup>b</sup>
	Heat-treated in blanks or individual lengths or hot forgings	Batch heat treatment	100 pup joints or 400 accessories	2	—
		Heat-treated in sequential loads or continuous heat treatment	In accordance with 10.2.3	2	—
Group 2 Grades L80 9Cr L80 13Cr	Full-length standard tubing or casing from one or more heats		Label 1: ≤ 4-1/2: 200 Label 1: > 4-1/2: 100	2 <sup>b</sup>	—
	Thick-wall mechanical tube or bar stock from a single heat		Label 1: ≤ 4-1/2: 200 Label 1: > 4-1/2: 100	2 <sup>b</sup>	—
	Heat-treated in blanks or individual lengths or hot forgings	Batch heat treatment	100 pup joints or 400 accessories	2	—
		Heat-treated in sequential loads or continuous heat treatment	In accordance with 10.2.3	2	—
Group 2 Grades C90 and T95	Full-length standard tubing or casing from one or more heats		Label 1: ≤ 4-1/2: 200 Label 1: > 4-1/2: 100	1	—
	Thick-wall mechanical tube or bar stock from a single heat		1	1 <sup>b</sup>	—
	Heat-treated in blanks or individual lengths or hot forgings	Batch heat treatment	Label 1: < 9-5/8: 50 <sup>c</sup> Label 1: ≥ 9-5/8: 30 <sup>c</sup>	1	—
		Heat-treated in sequential loads or continuous heat treatment	Label 1: < 9-5/8: 50 <sup>c</sup> Label 1: ≥ 9-5/8: 30 <sup>c</sup>	1	—
Group 4 Grade Q125	Full-length standard tubing or casing from one or more heats		In accordance with 10.2.3	3 <sup>b</sup>	—
	Thick-wall mechanical tube or bar stock from a single heat		1	1 <sup>b</sup>	—
	Heat-treated in blanks or individual lengths or hot forgings	Batch heat treatment	Label 1: < 9-5/8: 50 <sup>c</sup> Label 1: ≥ 9-5/8: 30 <sup>c</sup>	1	—
		Heat-treated in sequential loads or continuous heat treatment	Label 1: < 9-5/8: 50 <sup>c</sup> Label 1: ≥ 9-5/8: 30 <sup>c</sup>	1	—

<sup>a</sup> Accessories shall be made from seamless material or hot forgings.

<sup>b</sup> Approximately 50 % from each end.

<sup>c</sup> Each lot shall be from the same heat of steel for Grades L80 9Cr, L80 13Cr, C90, T95 and Q125. See 10.2.3.

**Table C.43 — Frequency of hardness testing**

Grade	Product		Number of tests per lot	Maximum number of pieces in a lot	Type of test	Location	
1	2		3	4	5	6	
Grades M65, L80	Pipe, coupling stock, thick-wall mechanical tubes, bar stock	Label 1: ≤ 4-1/2	2 <sup>a</sup>	200 <sup>b, c</sup>	Through-wall, 1 quadrant	Pipe, tube or stock body tensile test	
		Label 1: > 4-1/2	2 <sup>a</sup>	100 <sup>b, c</sup>	Through-wall, 1 quadrant	Pipe, tube or stock body tensile test	
	Coupling blanks or hot forgings		2 <sup>a</sup>	Heat-treat lot or 400 couplings <sup>b, c</sup>	Through-wall, 1 quadrant	Coupling blank tensile test	
	Pup joints and accessories (heat-treated in blank or individual lengths)	Batch heat treatment (method a, 10.2.3)	2 <sup>a</sup>	100 pup joints or 400 accessories <sup>b, c</sup>	Through-wall, 1 quadrant	Pup joint or accessory tensile test	
		Heat-treated in sequential loads (method b, 10.2.3)	2 <sup>a</sup>	Lot (see 10.2) <sup>b, c</sup>	Through-wall, 1 quadrant	Pup joint or accessory tensile test	
		Continuous heat treatment (method c, 10.2.3)	2 <sup>a</sup>	Lot (see 10.2) <sup>b, c</sup>	Through-wall, 1 quadrant	Pup joint or accessory tensile test	
Grades C90, T95	As-quenched product		1	Each production run or heat treatment practice	Through-wall, 4 quadrants	Design area of greatest thickness	
	Non-upset pipe		1	Each length	Through-wall, 1 quadrant	Approx. 50 % from each end	
	Upset pipe			1	Each length	Surface – HRC or HBW	Pipe body and one upset <sup>d</sup>
				1	20 <sup>c</sup>	Through-wall, 4 quadrants	One upset
				1	Label 1: ≤ 4-1/2: 200 Label 1: > 4-1/2: 100	Through-wall, 4 quadrants	Pipe body tensile test
	Couplings, pup joints and accessories	Tube-length heat treatment	2	Each length	Through-wall, 4 quadrants	One from each end	
		Individual heat treatment	1	Each piece	Surface – HRC or HBW	Each piece	
			1	Label 1: < 9-5/8: 50 <sup>c</sup> Label 1: ≥ 9-5/8: 30 <sup>c</sup>	Through-wall, 4 quadrants	From a piece with the highest surface hardness number in the lot	
Grade Q125	Casing		3	Lot (see 10.2) <sup>b, c</sup>	Through-wall, 1 quadrant	Pipe body	
	Couplings, pup joints and accessories	Tube-length heat treatment	1	Each length	Through-wall, 1 quadrant	Approx. 50 % from each end	
		Individual heat treatment	1	Each piece	Surface – HRC or HBW	Each piece	
			1	Label 1: < 9-5/8: 50 <sup>c</sup> Label 1: ≥ 9-5/8: 30 <sup>c</sup>	Through-wall, 1 quadrant	Randomly selected piece	
<sup>a</sup>	Lots which include more than one heat shall have two hardness tests from each heat.						
<sup>b</sup>	The lengths tested shall be selected randomly and represent the start and end of the heat treatment cycle.						
<sup>c</sup>	Each lot shall be from the same heat of steel for Grades L80 9Cr, L80 13Cr, C90, T95 and Q125.						
<sup>d</sup>	One upset approximately 50 % from each end if both ends are upset.						



**Table C.44 — Frequency of flattening tests**

Casing and tubing					
Group	Type of heat treatment		Number of tests		
1	2	3	4		
1, 2 and 3	Non-full-body		As described in footnote a		
	Full body	≤ Label 1: 4-1/2	Same as non-full-body heat-treated or 1 per lot of 100 lengths or less		
		> Label 1: 4-1/2 <sup>b</sup>	Same as non-full-body heat-treated or 1 per lot of 20 lengths or less		
4	All		1 on each end of each length of pipe [see A.5 (SR11)]		
Pup joints					
Group	Source of pup joint		Maximum number of pieces in a lot	Number of tests	
				per lot	per heat
1	2	3	4	5	6
1, 2 and 3	Treated separately	Batch heat-treated	100 pup joints	1	1
		Continuously heat-treated	—		
	Manufactured from EW pipe	≤ Label 1: 4-1/2	200 lengths		
		> Label 1: 4-1/2 <sup>b</sup>	100 lengths		
4	All		1 on each end of each length of pipe		
<p><sup>a</sup> The leading end of the first pipe of each coil shall have two test specimens flattened: one in the 90° position and one in the 0° position. Two test specimens shall be flattened from an intermediate pipe of each coil: one in the 90° position and one in the 0° position. The trailing end of the last pipe of each coil shall have two test specimens flattened: one in the 90° position and one in the 0° position. When a weld stop condition occurs during production of a multiple length, flattening tests with the weld at the 90° position and 0° position shall be made from the crop end resulting from each side of the weld stop, and may be substituted for the intermediate flattening tests. 90° position: the weld is positioned at 3 o'clock or at 9 o'clock. 0° position: the weld is positioned at 6 o'clock or at 12 o'clock.</p> <p><sup>b</sup> Includes casing used as tubing.</p>					

**Table C.45 — Hydrostatic test pressure for Grade H40 casing**

Labels		Test pressure MPa		
		Plain end	Round thread <sup>a</sup>	
1	2			STC
1	2	3	4	5
4-1/2	9.50	20,0	20,0	—
5-1/2	14.00	19,5	19,5	—
6-5/8	20.00	19,0	19,0	—
7	17.00	14,5	14,5	—
7	20.00	17,0	17,0	—
7-5/8	24.00	17,5	17,5	—
8-5/8	28.00	15,5	15,5	—
8-5/8	32.00	18,0	18,0	—
9-5/8	32.30	14,5	14,5	—
9-5/8	36.00	16,0	16,0	—
10-3/4	32.75	8,5 (11,5)	8,5 (11,5)	— —
10-3/4	40.50	11,0 (14,5)	11,0 (14,5)	— —
11-3/4	42.00	9,5 (12,5)	9,5 (12,5)	— —
13-3/8	48.00	8,0 (11,0)	8,0 (11,0)	— —
16	65.00	8,0 (10,5)	8,0 (10,5)	— —
18-5/8	87.50	7,5 (10,5)	7,5 (10,5)	— —
20	94.00	7,5 (9,5)	7,5 (9,5)	7,5 (9,5)

NOTE Alternative test pressures are given in parentheses.

<sup>a</sup> The test pressures shown are for threaded and coupled pipe furnished with H40, J55 or K55 couplings.

**Table C.46 — Hydrostatic test pressure for Grades J55 and K55 casing**

Labels		Test pressure MPa							
		Plain end	Round thread		Buttress thread				XC
STC	LC		Regular coupling		Special-clearance coupling				
			J55 K55	L80	J55 K55	L80			
1	2	3	4	5	6	7	8	9	10
3-1/2 <sup>a</sup>	9.91	50,0	—	—	—	—	—	—	—
4 <sup>a</sup>	11.34	43,5	—	—	—	—	—	—	—
4-1/2	9.50	27,5	27,5	—	—	—	—	—	—
4-1/2	10.50	30,0	30,0	—	30,0	30,0	30,0	30,0	—
4-1/2	11.60	33,5	33,5	33,5	33,5	33,5	30,5	33,5	—
4-1/2 <sup>a</sup>	13.04	39,0	—	—	—	—	—	—	—
5	11.50	26,5	26,5	—	—	—	—	—	—
5	13.00	30,5	30,5	30,5	30,5	30,5	28,5	30,5	—
5	15.00	36,0	36,0	36,0	36,0	36,0	28,0	36,0	36,0
5 <sup>a</sup>	17.93	44,0	—	—	—	—	—	—	—
5-1/2	14.00	27,0	27,0	—	—	—	—	—	—
5-1/2	15.50	30,5	30,5	30,5	30,5	30,5	26,0	30,5	30,5
5-1/2	17.00	33,5	33,5	33,5	33,5	33,5	26,0	33,5	33,5
5-1/2 <sup>a</sup>	19.81	40,0	—	—	—	—	—	—	—
6-5/8	20.00	26,5	26,5	26,5	26,5	26,5	22,5	26,5	—
6-5/8	24.00	32,0	32,0	32,0	32,0	32,0	22,5	32,0	32,0
6-5/8 <sup>a</sup>	27.65	38,0	—	—	—	—	—	—	—
7	20.00	23,5	23,5	—	—	—	—	—	—
7	23.00	27,5	27,5	27,5	27,5	27,5	21,5	27,5	27,5
7	26.00	31,5	31,5	31,5	31,5	31,5	21,5	31,5	31,5
7-5/8	26.40	26,0	26,0	26,0	26,0	26,0	25,0	26,0	—
8-5/8	24.00	18,5	18,5	—	—	—	—	—	—
8-5/8	32.00	24,5	24,5	24,5	24,5	24,5	22,5	24,5	24,5
8-5/8	36.00	28,0	28,0	28,0	28,0	28,0	22,5	28,0	28,0
9-5/8	36.00	22,0	22,0	22,0	22,0	22,0	20,0	22,0	—
9-5/8	40.00	25,0	25,0	25,0	25,0	25,0	20,0	25,0	25,0
10-3/4	40.50	15,0 (19,5)	15,0 (19,5)	—	15,0 (19,5)	15,0 (19,5)	15,0 (18,0)	15,0 (19,5)	—
10-3/4	45.50	17,0 (22,5)	17,0 (22,5)	—	17,0 (22,5)	17,0 (22,5)	17,0 (18,0)	17,0 (22,5)	17,0 (22,5)
10-3/4	51.00	19,0 (25,5)	19,0 (25,5)	—	19,0 (25,5)	19,0 (25,5)	18,0 (18,0)	19,0 (25,5)	19,0 (25,5)
11-3/4	47.00	14,5 (19,5)	14,5 (19,5)	—	14,5 (19,5)	14,5 (19,5)	—	—	—
11-3/4	54.00	17,0 (22,5)	17,0 (22,5)	—	17,0 (22,5)	17,0 (22,5)	—	—	—
11-3/4	60.00	19,0 (25,0)	19,0 (25,0)	—	19,0 (25,0)	19,0 (25,0)	—	—	—
13-3/8	54.50	13,0 (17,0)	13,0 (17,0)	—	13,0 (17,0)	13,0 (17,0)	—	—	—
13-3/8	61.00	14,5 (19,5)	14,5 (19,5)	—	14,5 (19,5)	14,5 (19,5)	—	—	—
13-3/8	68.00	16,5 (22,0)	16,5 (22,0)	—	16,5 (22,0)	16,5 (22,0)	—	—	—
16	75.00	12,5 (16,5)	12,5 (16,5)	—	12,5 (16,5)	12,5 (16,5)	—	—	—
16	84.00	14,0 (19,0)	14,0 (19,0)	—	14,0 (19,0)	14,0 (19,0)	—	—	—
16	109.00	18,5 (25,0)	—	—	—	—	—	—	—
18-5/8	87.50	10,5 (14,0)	10,5 (14,0)	—	10,5 (14,0)	10,5 (14,0)	—	—	—
20	94.00	10,0 (13,5)	10,0 (13,5)	10,0 (13,5)	10,0 (13,5)	10,0 (13,5)	—	—	—
20	106.50	11,5 (15,0)	11,5 (15,0)	11,5 (15,0)	11,5 (15,0)	11,5 (15,0)	—	—	—
20	133.00	14,5 (19,5)	14,5 (16,5)	14,5 (16,5)	14,5 (16,0)	14,5 (16,0)	—	—	—

NOTE Alternative test pressures are given in parentheses.

<sup>a</sup> Used as plain-end casing liner.

**Table C.47 — Hydrostatic test pressure for Grade M65 casing**

Labels		Test pressure MPa				
		Plain end	Round thread		Buttress thread <sup>a</sup>	
1	2		STC	LC	Regular coupling	Special-clearance coupling
1	2	3	4	5	6	7
4-1/2	9.50	32,5	32,5	—	—	—
4-1/2	10.50	35,5	35,5	—	35,5	35,5
4-1/2	11.60	40,0	—	40,0	40,0	40,0
4-1/2	13.50	46,0	—	46,0	46,0	44,0
5	11.50	31,5	31,5	—	—	—
5	13.00	36,5	36,5	36,5	36,5	36,5
5	15.00	42,5	—	42,5	42,5	41,0
5	18.00	52,0	—	52,0	52,0	41,0
5	21.40	62,5	—	59,5	54,5	41,0
5-1/2	14.00	32,0	32,0	—	—	—
5-1/2	15.50	36,0	36,0	36,0	36,0	36,0
5-1/2	17.00	39,5	—	39,5	39,5	38,0
5-1/2	20.00	47,0	—	47,0	47,0	38,0
5-1/2	23.00	54,0	—	54,0	49,5	38,0
6-5/8	20.00	31,0	31,0	31,0	31,0	31,0
6-5/8	24.00	36,0	—	36,0	36,0	32,5
6-5/8	28.00	45,0	—	45,0	45,0	32,5
7	20.00	28,0	28,0	—	—	—
7	23.00	32,5	—	32,5	32,5	31,5
7	26.00	37,0	—	37,0	37,0	31,5
7	29.00	42,0	—	42,0	42,0	31,5
7	32.00	46,5	—	46,5	46,5	31,5
7-5/8	26.40	31,0	31,0	31,0	31,0	31,0
7-5/8	29.70	35,0	—	35,0	35,0	35,0
7-5/8	33.70	40,5	—	40,5	40,5	36,0
8-5/8	24.00	22,0	22,0	—	—	—
8-5/8	28.00	25,5	25,5	—	—	—
8-5/8	32.00	29,5	29,5	29,5	29,5	29,5
8-5/8	36.00	33,0	33,0	33,0	33,0	32,5
8-5/8	40.00	37,5	—	37,5	37,5	32,5
9-5/8	36.00	26,0	26,0	26,0	26,0	26,0
9-5/8	40.00	29,5	29,5	29,5	29,5	29,5
9-5/8	43.50	32,5	—	32,5	32,5	29,5
9-5/8	47.00	35,0	—	35,0	35,0	29,5
10-3/4	40.50	23,5	23,5	—	23,5	23,5
10-3/4	45.50	26,5	26,5	—	26,5	26,5
10-3/4	51.00	30,0	30,0	—	30,0	26,5
10-3/4	55.50	33,0	33,0	—	33,0	26,5
11-3/4	47.00	23,0	23,0	—	23,0	—
11-3/4	54.00	26,5	26,5	—	26,5	—
11-3/4	60.00	30,0	30,0	—	30,0	—
13-3/8	54.50	20,5	20,5	—	20,5	—
13-3/8	61.00	23,0	23,0	—	23,0	—
13-3/8	68.00	25,5	25,5	—	25,5	—
16	75.00	19,5	19,5	—	19,5	—
16	84.00	22,0	22,0	—	22,0	—
18-5/8	87.50	16,5	16,5	—	16,5	—
20	94.00	15,5	14,5	15,5	15,5	—
20	106.50	18,0	14,5	16,5	16,0	—

<sup>a</sup> Threaded and coupled grade M65 casing shall be furnished with grade L80 Type 1 couplings.

**Table C.48 — Hydrostatic test pressure for Grade L80 casing**

Labels		Test pressure MPa						XC
		Plain end	Round thread		Buttress thread			
1	2		STC	LC	Regular coupling	Special-clearance coupling		
1	2	3	4	5	6	7	8	
4-1/2	11.60	49,0	—	49,0	49,0	44,0	—	
4-1/2	13.50	57,0	—	57,0	54,0	44,0	—	
5	15.00	52,5	—	52,5	52,5	41,0	52,5	
5	18.00	64,0	—	59,5	54,5	41,0	64,0	
5	21.40	69,0	—	59,5	54,5	41,0	—	
5	23.20	69,0	—	59,5	54,5	41,0	—	
5	24.10	69,0	—	59,5	54,5	41,0	—	
5-1/2	17.00	49,0	—	49,0	49,0	38,0	49,0	
5-1/2	20.00	58,0	—	54,5	49,5	38,0	58,0	
5-1/2	23.00	66,5	—	54,5	49,5	38,0	66,5	
6-5/8	24.00	47,0	—	47,0	47,0	32,5	47,0	
6-5/8	28.00	55,5	—	55,5	54,0	32,5	55,5	
6-5/8	32.00	63,5	—	59,0	54,0	32,5	63,5	
7	23.00	40,0	—	40,0	40,0	31,5	40,0	
7	26.00	45,5	—	45,5	45,5	31,5	45,5	
7	29.00	51,5	—	51,0	46,5	31,5	51,5	
7	32.00	57,0	—	51,0	46,5	31,5	57,0	
7	35.00	63,0	—	51,0	46,5	31,5	63,0	
7	38.00	68,0	—	51,0	46,5	31,5	68,0	
7-5/8	26.40	38,0	—	38,0	38,0	36,0	38,0	
7-5/8	29.70	43,5	—	43,5	43,5	36,0	43,5	
7-5/8	33.70	50,0	—	50,0	50,0	36,0	50,0	
7-5/8	39.00	58,0	—	58,0	54,0	36,0	58,0	
7-5/8	42.80	65,0	—	58,0	54,0	36,0	—	
7-5/8	45.30	69,0	—	58,0	54,0	36,0	—	
7-5/8	47.10	69,0	—	58,0	54,0	36,0	—	
7-3/4	46.10	68,0	—	—	—	—	—	
8-5/8	36.00	41,0	—	41,0	41,0	32,5	41,0	
8-5/8	40.00	46,0	—	46,0	46,0	32,5	46,0	
8-5/8	44.00	51,0	—	51,0	51,0	32,5	51,0	
8-5/8	49.00	57,0	—	57,0	54,0	32,5	57,0	
9-5/8	40.00	36,0	—	36,0	36,0	29,5	36,0	
9-5/8	43.50	40,0	—	40,0	40,0	29,5	40,0	
9-5/8	47.00	43,5	—	43,5	43,5	29,5	43,5	
9-5/8	53.50	50,0	—	50,0	49,0	29,5	50,0	
9-5/8	58.40	54,5	—	53,0	49,0	29,5	—	
10-3/4	51.00	37,0	37,0	—	37,0	26,5	37,0	
10-3/4	55.50	40,5	40,5	—	40,5	26,5	40,5	
11-3/4	60.00	37,0	37,0	—	37,0	—	—	
11-3/4	65.00	40,0	—	—	—	—	—	
11-3/4	71.00	43,5	—	—	—	—	—	
13-3/8	68.00	31,5	31,5	—	31,5	—	—	
13-3/8	72.00	34,0	31,5	—	34,0	—	—	
16	109.00	36,0	—	—	—	—	—	

**Table C.49 — Hydrostatic test pressure for Grade N80 Type 1 and N80Q casing**

Labels		Test pressure MPa							XC
		Plain end	Round thread		Buttress thread				
STC	LC		Regular coupling		Special-clearance coupling				
			N80	P110	N80	P110			
1	2	3	4	5	6	7	8	9	10
4-1/2	11.60	49,0	—	49,0	49,0	49,0	44,0	49,0	—
4-1/2	13.50	57,0	—	57,0	54,0	57,0	44,0	57,0	—
5	15.00	52,5	—	52,5	52,5	52,5	41,0	52,5	52,5
5	18.00	64,0	—	59,5	54,5	64,0	41,0	56,5	64,0
5	21.40	69,0	—	59,5	54,5	69,0	41,0	56,5	—
5	23.20	69,0	—	59,5	54,5	69,0	41,0	56,5	—
5	24.10	69,0	—	59,5	54,5	69,0	41,0	56,5	—
5-1/2	17.00	49,0	—	49,0	49,0	49,0	38,0	49,0	49,0
5-1/2	20.00	58,0	—	54,5	49,5	58,0	38,0	52,0	58,0
5-1/2	23.00	66,5	—	54,5	49,5	66,5	38,0	52,0	66,5
6-5/8	24.00	47,0	—	47,0	47,0	47,0	32,5	45,0	47,0
6-5/8	28.00	55,5	—	55,5	54,0	55,5	32,5	45,0	55,5
6-5/8	32.00	63,5	—	59,0	54,0	63,5	32,5	45,0	63,5
7	23.00	40,0	—	40,0	40,0	40,0	31,5	40,0	40,0
7	26.00	45,5	—	45,5	45,5	45,5	31,5	43,5	45,5
7	29.00	51,5	—	51,0	46,5	51,5	31,5	43,5	51,5
7	32.00	57,0	—	51,0	46,5	57,0	31,5	43,5	57,0
7	35.00	63,0	—	51,0	46,5	63,0	31,5	43,5	63,0
7	38.00	68,0	—	51,0	46,5	64,0	31,5	43,5	68,0
7-5/8	26.40	38,0	—	38,0	38,0	38,0	36,0	38,0	38,0
7-5/8	29.70	43,5	—	43,5	43,5	43,5	36,0	43,5	43,5
7-5/8	33.70	50,0	—	50,0	50,0	50,0	36,0	49,5	50,0
7-5/8	39.00	58,0	—	58,0	54,0	58,0	36,0	49,5	58,0
7-5/8	42.80	65,0	—	58,0	54,0	65,0	36,0	49,5	—
7-5/8	45.30	69,0	—	58,0	54,0	69,0	36,0	49,5	—
7-5/8	47.10	69,0	—	58,0	54,0	69,0	36,0	49,5	—
7-3/4	46.10	68,0	—	—	—	—	—	—	—
8-5/8	36.00	41,0	—	41,0	41,0	41,0	32,5	41,0	41,0
8-5/8	40.00	46,0	—	46,0	46,0	46,0	32,5	44,0	46,0
8-5/8	44.00	51,0	—	51,0	51,0	51,0	32,5	44,0	51,0
8-5/8	49.00	57,0	—	57,0	54,0	57,0	32,5	44,0	57,0
9-5/8	40.00	36,0	—	36,0	36,0	36,0	29,5	35,5	36,0
9-5/8	43.50	40,0	—	40,0	40,0	40,0	29,5	35,5	40,0
9-5/8	47.00	43,5	—	43,5	43,5	43,5	29,5	35,5	43,5
9-5/8	53.50	50,0	—	50,0	49,0	50,0	29,5	35,5	50,0
9-5/8	58.40	54,5	—	53,0	49,0	54,5	29,5	35,5	—
10-3/4	51.00	37,0	37,0	—	37,0	37,0	26,5	28,5	37,0
10-3/4	55.50	40,5	40,5	—	40,5	40,5	26,5	28,5	40,5
11-3/4	60.00	37,0	37,0	—	37,0	37,0	—	—	—
11-3/4	65.00	40,0	—	—	—	—	—	—	—
11-3/4	71.00	43,5	—	—	—	—	—	—	—
13-3/8	68.00	31,5	31,5	—	31,5	31,5	—	—	—
13-3/8	72.00	34,0	31,5	—	34,0	34,0	—	—	—
16	109.00	36,0	—	—	—	—	—	—	—

**Table C.50 — Hydrostatic test pressure for Grade C90 casing**

Labels		Test pressure MPa					
		Plain end	Round thread		Buttress thread		XC
1	2		STC	LC	Regular coupling	Special-clearance coupling	
1	2	3	4	5	6	7	8
4-1/2	11.60	55,0	—	55,0	55,0	49,5	—
4-1/2	13.50	64,0	—	64,0	61,0	49,5	—
5	15.00	59,0	—	59,0	59,0	46,5	59,0
5	18.00	69,0	—	67,0	61,5	46,5	69,0
5	21.40	69,0	—	67,0	61,5	46,5	—
5	23.20	69,0	—	67,0	61,5	46,5	—
5	24.10	69,0	—	67,0	61,5	46,5	—
5-1/2	17.00	55,0	—	55,0	55,0	42,5	55,0
5-1/2	20.00	65,0	—	61,5	56,0	42,5	65,0
5-1/2	23.00	69,0	—	61,5	56,0	42,5	69,0
5-1/2	26.80	69,0	—	—	—	—	—
5-1/2	29.70	69,0	—	—	—	—	—
5-1/2	32.60	69,0	—	—	—	—	—
5-1/2	35.30	69,0	—	—	—	—	—
5-1/2	38.00	69,0	—	—	—	—	—
5-1/2	40.50	69,0	—	—	—	—	—
5-1/2	43.10	69,0	—	—	—	—	—
6-5/8	24.00	53,0	—	53,0	53,0	36,5	53,0
6-5/8	28.00	62,5	—	62,5	61,0	36,5	62,5
6-5/8	32.00	69,0	—	66,5	61,0	36,5	69,0
7	23.00	45,0	—	45,0	45,0	35,5	45,0
7	26.00	51,5	—	51,5	51,5	35,5	51,5
7	29.00	58,0	—	57,5	52,5	35,5	58,0
7	32.00	64,5	—	57,5	52,5	35,5	64,5
7	35.00	69,0	—	57,5	52,5	35,5	69,0
7	38.00	69,0	—	57,5	52,5	35,5	69,0
7	42.70	69,0	—	—	—	—	—
7	46.40	69,0	—	—	—	—	—
7	50.10	69,0	—	—	—	—	—
7	53.60	69,0	—	—	—	—	—
7	57.10	69,0	—	—	—	—	—
7-5/8	26.40	42,5	—	42,5	42,5	40,5	42,5
7-5/8	29.70	49,0	—	49,0	49,0	40,5	49,0
7-5/8	33.70	56,0	—	56,0	56,0	40,5	56,0
7-5/8	39.00	65,0	—	65,0	61,0	40,5	65,0
7-5/8	42.80	69,0	—	65,0	61,0	40,5	—
7-5/8	45.30	69,0	—	65,0	61,0	40,5	—
7-5/8	47.10	69,0	—	65,0	61,0	40,5	—
7-5/8	51.20	69,0	—	—	—	—	—
7-5/8	55.30	69,0	—	—	—	—	—
7-3/4	46.10	69,0	—	—	—	—	—
8-5/8	36.00	46,0	—	46,0	46,0	36,5	46,0
8-5/8	40.00	52,0	—	52,0	52,0	36,5	52,0
8-5/8	44.00	57,5	—	57,5	57,5	36,5	57,5
8-5/8	49.00	64,0	—	64,0	60,5	36,5	64,0

Table C.50 (continued)

Labels		Test pressure MPa					XC
		Plain end	Round thread		Buttress thread		
1	2		STC	LC	Regular coupling	Special-clearance coupling	
1	2	3	4	5	6	7	8
9-5/8	40.00	41,0	—	41,0	41,0	33,0	41,0
9-5/8	43.50	45,0	—	45,0	45,0	33,0	45,0
9-5/8	47.00	48,5	—	48,5	48,5	33,0	48,5
9-5/8	53.50	56,0	—	56,0	55,0	33,0	56,0
9-5/8	58.40	61,5	—	58,5	55,0	33,0	—
9-5/8	59.40	63,0	—	—	—	—	—
9-5/8	64.90	69,0	—	—	—	—	—
9-5/8	70.30	69,0	—	—	—	—	—
9-5/8	75.60	69,0	—	—	—	—	—
10-3/4	51.00	41,5	41,5	—	41,5	28,5	41,5
10-3/4	55.50	45,5	45,5	—	45,5	28,5	45,5
10-3/4	60.70	50,5	47,5	—	49,5	28,5	50,5
10-3/4	65.70	55,0	47,5	—	49,5	28,5	—
10-3/4	73.20	62,0	—	—	—	—	—
10-3/4	79.20	68,0	—	—	—	—	—
10-3/4	85.30	69,0	—	—	—	—	—
11-3/4	60.00	41,5	40,0	—	41,5	—	—
11-3/4	65.00	45,0	—	—	—	—	—
11-3/4	71.00	49,0	—	—	—	—	—
13-3/8	68.00	35,5	31,5	—	34,0	—	—
13-3/8	72.00	38,0	31,5	—	34,0	—	—



**Table C.51 — Hydrostatic test pressure for Grade C95 casing**

Labels		Test pressure MPa					
		Plain end	Round thread		Buttress thread		XC
1	2		STC	LC	Regular coupling	Special-clearance coupling	
1	2	3	4	5	6	7	8
4-1/2	11.60	58,0	—	58,0	58,0	52,5	—
4-1/2	13.50	67,5	—	67,5	64,0	52,5	—
5	15.00	62,0	—	62,0	62,0	49,0	62,0
5	18.00	69,0	—	69,0	65,0	49,0	69,0
5	21.40	69,0	—	69,0	65,0	49,0	—
5	23.20	69,0	—	69,0	65,0	49,0	—
5	24.10	69,0	—	69,0	65,0	49,0	—
5-1/2	17.00	58,0	—	58,0	58,0	45,0	58,0
5-1/2	20.00	69,0	—	64,5	59,0	45,0	69,0
5-1/2	23.00	69,0	—	64,5	59,0	45,0	69,0
6-5/8	24.00	55,5	—	55,5	55,5	38,5	55,5
6-5/8	28.00	66,0	—	66,0	64,5	38,5	66,0
6-5/8	32.00	69,0	—	69,0	64,5	38,5	69,0
7	23.00	47,5	—	47,5	47,5	37,5	47,5
7	26.00	54,0	—	54,0	54,0	37,5	54,0
7	29.00	61,0	—	60,5	55,5	37,5	61,0
7	32.00	68,0	—	60,5	55,5	37,5	68,0
7	35.00	69,0	—	60,5	55,5	37,5	69,0
7	38.00	69,0	—	60,5	55,5	37,5	69,0
7-5/8	26.40	45,0	—	45,0	45,0	43,0	45,0
7-5/8	29.70	51,5	—	51,5	51,5	43,0	51,5
7-5/8	33.70	59,0	—	59,0	59,0	43,0	59,0
7-5/8	39.00	68,5	—	68,5	64,0	43,0	68,5
7-5/8	42.80	69,0	—	68,5	64,0	43,0	—
7-5/8	45.30	69,0	—	68,5	64,0	43,0	—
7-5/8	47.10	69,0	—	68,5	64,0	43,0	—
7-3/4	46.10	69,0	—	—	—	—	—
8-5/8	36.00	48,5	—	48,5	48,5	38,5	48,5
8-5/8	40.00	54,5	—	54,5	54,5	38,5	54,5
8-5/8	44.00	61,0	—	61,0	61,0	38,5	61,0
8-5/8	49.00	67,5	—	67,5	64,0	38,5	67,5
9-5/8	40.00	43,0	—	43,0	43,0	35,0	43,0
9-5/8	43.50	47,5	—	47,5	47,5	35,0	47,5
9-5/8	47.00	51,5	—	51,5	51,5	35,0	51,5
9-5/8	53.50	59,5	—	58,5	58,0	35,0	59,5
9-5/8	58.40	65,0	—	58,5	58,0	35,0	—
10-3/4	51.00	44,0	44,0	—	44,0	28,5	44,0
10-3/4	55.50	48,0	47,5	—	48,0	28,5	48,0
11-3/4	60.00	43,5	40,0	—	43,5	—	—
11-3/4	65.00	47,5	—	—	—	—	—
11-3/4	71.00	52,0	—	—	—	—	—
13-3/8	68.00	37,5	31,5	—	34,0	—	—
13-3/8	72.00	40,5	31,5	—	34,0	—	—
16	109.00	43,0	—	—	—	—	—

**Table C.52 — Hydrostatic test pressure for Grade T95 casing**

Labels		Test pressure MPa					XC
		Plain end	Round thread		Buttress thread		
1	2		STC	LC	Regular coupling	Special-clearance coupling	
1	2	3	4	5	6	7	8
4-1/2	11.60	58.0	—	58.0	58.0	52.5	—
4-1/2	13.50	67,5	—	67,5	64,0	52,5	—
5	15.00	62,0	—	62,0	62,0	49,0	62,0
5	18.00	69,0	—	69,0	65,0	49,0	69,0
5	21.40	69,0	—	69,0	65,0	49,0	—
5	23.20	69,0	—	69,0	65,0	49,0	—
5	24.10	69,0	—	69,0	65,0	49,0	—
5-1/2	17.00	58,0	—	58,0	58,0	45,0	58,0
5-1/2	20.00	69,0	—	64,5	59,0	45,0	69,0
5-1/2	23.00	69,0	—	64,5	59,0	45,0	69,0
5-1/2	26.80	69,0	—	—	—	—	—
5-1/2	29.70	69,0	—	—	—	—	—
5-1/2	32.60	69,0	—	—	—	—	—
5-1/2	35,30	69,0	—	—	—	—	—
5-1/2	38.00	69,0	—	—	—	—	—
5-1/2	40.50	69,0	—	—	—	—	—
5-1/2	43.10	69,0	—	—	—	—	—
6-5/8	24.00	55,5	—	55,5	55,5	38,5	55,5
6-5/8	28.00	66,0	—	66,0	64,5	38,5	66,0
6-5/8	32.00	69,0	—	69,0	64,5	38,5	69,0
7	23.00	47,5	—	47,5	47,5	37,5	47,5
7	26.00	54,0	—	54,0	54,0	37,5	54,0
7	29.00	61,0	—	60,5	55,5	37,5	61,0
7	32.00	68,0	—	60,5	55,5	37,5	68,0
7	35.00	69,0	—	60,5	55,5	37,5	69,0
7	38.00	69,0	—	60,5	55,5	37,5	69,0
7	42.70	69,0	—	—	—	—	—
7	46.40	69,0	—	—	—	—	—
7	50.10	69,0	—	—	—	—	—
7	53.60	69,0	—	—	—	—	—
7	57.10	69,0	—	—	—	—	—
7-5/8	26.40	45,0	—	45,0	45,0	43,0	45,0
7-5/8	29.70	51,5	—	51,5	51,5	43,0	51,5
7-5/8	33.70	59,0	—	59,0	59,0	43,0	59,0
7-5/8	39.00	68,5	—	68,5	64,0	43,0	68,5
7-5/8	42.80	69,0	—	68,5	64,0	43,0	—
7-5/8	45.30	69,0	—	68,5	64,0	43,0	—
7-5/8	47.10	69,0	—	68,5	64,0	43,0	—
7-5/8	51.20	69,0	—	—	—	—	—
7-5/8	55.30	69,0	—	—	—	—	—
7-3/4	46.10	69,0	—	—	—	—	—
8-5/8	36.00	48,5	—	48,5	48,5	38,5	48,5
8-5/8	40.00	54,5	—	54,5	54,5	38,5	54,5
8-5/8	44.00	61,0	—	61,0	61,0	38,5	61,0
8-5/8	49.00	67,5	—	67,5	64,0	38,5	67,5

Table C.52 (continued)

Labels		Test pressure MPa					
		Plain end	Round thread		Buttress thread		XC
1	2		STC	LC	Regular coupling	Special-clearance coupling	
1	2	3	4	5	6	7	8
9-5/8	40.00	43,0	—	43,0	43,0	35,0	43,0
9-5/8	43.50	47,5	—	47,5	47,5	35,0	47,5
9-5/8	47.00	51,5	—	51,5	51,5	35,0	51,5
9-5/8	53.50	59,5	—	58,5	58,0	35,0	59,5
9-5/8	58.40	65,0	—	58,5	58,0	35,0	—
9-5/8	59.40	66,5	—	—	—	—	—
9-5/8	64.90	69,0	—	—	—	—	—
9-5/8	70.30	69,0	—	—	—	—	—
9-5/8	75.60	69,0	—	—	—	—	—
10-3/4	51.00	44,0	44,0	—	44,0	28,5	44,0
10-3/4	55.50	48,0	47,5	—	48,0	28,5	48,0
10-3/4	60.70	53,0	47,5	—	51,5	28,5	53,0
10-3/4	65.70	58,0	47,5	—	51,5	28,5	—
10-3/4	73.20	65,5	—	—	—	—	—
10-3/4	79.20	69,0	—	—	—	—	—
10-3/4	85.30	69,0	—	—	—	—	—
11-3/4	60.00	43,5	40,0	—	43,5	—	—
11-3/4	65.00	47,5	—	—	—	—	—
11-3/4	71.00	52,0	—	—	—	—	—
13-3/8	68.00	37,5	31,5	—	34,0	—	—
13-3/8	72.00	40,5	31,5	—	34,0	—	—

**Table C.53 — Hydrostatic test pressure for Grade P110 casing**

Labels		Test pressure MPa							
		Plain end	Round thread		Buttress thread				XC
			STC	LC	Regular coupling		Special-clearance coupling		
1	2				P110	Q125	P110	Q125	
1	2	3	4	5	6	7	8	9	10
4-1/2	11.60	67,5	—	67,5	67,5	67,5	60,5	67,5	—
4-1/2	13.50	69,0 (78,0)	—	69,0 (78,0)	69,0 (74,0)	69,0 (78,0)	60,5 (60,5)	69,0 (69,0)	—
4-1/2	15.10	69,0 (91,0)	—	69,0 (80,5)	69,0 (74,0)	69,0 (84,5)	60,5 (60,5)	69,0 (69,0)	—
5	15.00	69,0 (72,0)	—	69,0 (72,0)	69,0 (72,0)	69,0 (72,0)	56,5 (56,5)	64,5 (64,5)	69,0 (72,0)
5	18.00	69,0 (88,0)	—	69,0 (82,0)	69,0 (75,0)	69,0 (85,5)	56,5 (56,5)	64,5 (64,5)	69,0 (88,0)
5	21.40	69,0 (106,0)	—	69,0 (82,0)	69,0 (75,0)	69,0 (85,5)	56,5 (56,5)	64,5 (64,5)	—
5	23.20	69,0 (116,0)	—	69,0 (82,0)	69,0 (75,0)	69,0 (85,5)	56,5 (56,5)	64,5 (64,5)	—
5	24.10	69,0 (121,5)	—	69,0 (82,0)	69,0 (75,0)	69,0 (85,5)	56,5 (56,5)	64,5 (64,5)	—
5-1/2	17.00	67,0	—	67,0	67,0	67,0	52,0	59,5	67,0
5-1/2	20.00	69,0 (79,5)	—	69,0 (75,0)	68,0 (68,0)	69,0 (77,5)	52,0 (52,0)	59,5 (59,5)	69,0 (79,5)
5-1/2	23.00	69,0 (91,5)	—	69,0 (75,0)	68,0 (68,0)	69,0 (77,5)	52,0 (52,0)	59,5 (59,5)	69,0 (91,5)
6-5/8	24.00	64,5	—	64,5	64,5	64,5	45,0	51,0	64,5
6-5/8	28.00	69,0 (76,5)	—	69,0 (76,5)	69,0 (74,5)	69,0 (76,5)	45,0 (45,0)	51,0 (51,0)	69,0 (76,5)
6-5/8	32.00	69,0 (87,0)	—	69,0 (81,0)	69,0 (74,5)	69,0 (84,5)	45,0 (45,0)	51,0 (51,0)	69,0 (87,0)
7	26.00	62,5	—	62,5	62,5	62,5	43,5	49,5	62,5
7	29.00	69,0 (70,5)	—	65,5 (65,5)	64,0 (64,0)	69,0 (70,5)	43,5 (43,5)	49,5 (49,5)	69,0 (70,5)
7	32.00	69,0 (78,5)	—	65,5 (65,5)	64,0 (64,0)	69,0 (73,0)	43,5 (43,5)	49,5 (49,5)	69,0 (78,5)
7	35.00	69,0 (86,5)	—	65,5 (65,5)	64,0 (64,0)	69,0 (73,0)	43,5 (43,5)	49,5 (49,5)	69,0 (86,5)
7	38.00	69,0 (93,5)	—	65,5 (65,5)	64,0 (64,0)	69,0 (73,0)	43,5 (43,5)	49,5 (49,5)	69,0 (93,5)
7-5/8	29.70	59,5	—	59,5	59,5	59,5	49,5	55,5	59,5
7-5/8	33.70	68,5	—	68,5	68,5	68,5	49,5	55,5	68,5
7-5/8	39.00	69,0 (79,5)	—	69,0 (79,5)	69,0 (74,0)	69,0 (79,5)	49,5 (49,5)	55,5 (55,5)	69,0 (79,5)
7-5/8	42.80	69,0 (89,5)	—	69,0 (79,5)	69,0 (74,0)	69,0 (84,5)	49,5 (49,5)	55,5 (55,5)	—
7-5/8	45.30	69,0 (94,5)	—	69,0 (79,5)	69,0 (74,0)	69,0 (84,5)	49,5 (49,5)	55,5 (55,5)	—
7-5/8	47.10	69,0 (99,5)	—	69,0 (79,5)	69,0 (74,0)	69,0 (84,5)	49,5 (49,5)	55,5 (55,5)	—
7-3/4	46.10	69,0 (93,0)	—	—	—	—	—	—	—
8-5/8	40.00	63,5	—	63,5	63,5	63,5	44,0	44,0	63,5
8-5/8	44.00	69,0 (70,5)	—	69,0 (70,5)	69,0 (70,5)	69,0 (70,5)	44,0 (44,0)	44,0 (44,0)	69,0 (70,5)
8-5/8	49.00	69,0 (78,5)	—	69,0 (71,5)	69,0 (74,0)	69,0 (77,5)	44,0 (44,0)	44,0 (44,0)	69,0 (78,5)

See note at end of table.

**Table C.53 (continued)**

Labels		Test pressure MPa							
		Plain end	Round thread		Buttress thread				XC
			STC	LC	Regular coupling		Special-clearance coupling		
1	2				P110	Q125	P110	Q125	
1	2	3	4	5	6	7	8	9	10
9-5/8	43.50	55,0	—	55,0	55,0	55,0	35,5	35,5	55,0
9-5/8	47.00	59,5	—	59,5	59,5	59,5	35,5	35,5	59,5
9-5/8	53.50	68,5	—	67,0	63,0	63,0	35,5	35,5	68,5
9-5/8	58.40	69,0 (75,0)	—	67,0 (67,0)	63,0 (63,0)	63,0 (63,0)	35,5 (35,5)	35,5 (35,5)	—
10-3/4	51.00	51,0	51,0	—	51,0	51,0	28,5	28,5	51,0
10-3/4	55.50	56,0	54,5	—	51,5	51,5	28,5	28,5	56,0
10-3/4	60.70	61,5	54,5	—	51,5	51,5	28,5	28,5	61,5
10-3/4	65.70	67,0	54,5	—	51,5	51,5	28,5	28,5	—
11-3/4	60.00	50,5	46,0	—	43,5	43,5	—	—	—
11-3/4	65.00	55,0	—	—	—	—	—	—	—
11-3/4	71.00	60,0	—	—	—	—	—	—	—
13-3/8	68.00	43,5	36,0	—	34,0	34,0	—	—	—
13-3/8	72.00	46,5	36,0	—	34,0	34,0	—	—	—
16	109.00	49,5	—	—	—	—	—	—	—

NOTE Alternative test pressures are given in parentheses.

**Table C.54 — Hydrostatic test pressure for Grade Q125 casing**

Labels		Test pressure MPa				
		Plain end	Round thread		Buttress thread, regular coupling	XC
1	2		STC	LC		
1	2	3	4	5	6	7
4-1/2	15.10	69,0 (103,5)	— —	69,0 (92,0)	69,0 (84,5)	— —
5	18.00	69,0 (100,0)	— —	69,0 (93,5)	69,0 (85,5)	69,0 (100,0)
5	21.40	69,0 (120,5)	— —	69,0 (93,5)	69,0 (85,5)	— —
5	23.20	69,0 (132,0)	— —	69,0 (93,5)	69,0 (85,5)	— —
5	24.10	69,0 (138,0)	— —	69,0 (93,5)	69,0 (85,5)	— —
5-1/2	23.00	69,0 (104,0)	— —	69,0 (85,0)	69,0 (77,5)	69,0 (104,0)
6-5/8	32.00	69,0 (99,0)	— —	69,0 (81,5)	69,0 (84,5)	69,0 (99,0)
7	35.00	69,0 (98,0)	— —	65,5 (65,5)	69,0 (73,0)	69,0 (98,0)
7	38.00	69,0 (106,5)	— —	65,5 (65,5)	69,0 (73,0)	69,0 (106,5)
7-5/8	39.00	69,0 (90,5)	— —	69,0 (81,5)	69,0 (84,5)	69,0 (90,5)
7-5/8	42.80	69,0 (101,5)	— —	69,0 (81,5)	69,0 (84,5)	— —
7-5/8	45.30	69,0 (107,5)	— —	69,0 (81,5)	69,0 (84,5)	— —
7-5/8	47.10	69,0 (113,0)	— —	69,0 (81,5)	69,0 (84,5)	— —
7-3/4	46.10	69,0 (106,0)	— —	— —	— —	— —
8-5/8	49.00	69,0 (89,0)	— —	69,0 (71,5)	69,0 (77,5)	69,0 (89,0)
9-5/8	47.00	67,5	—	67,0	63,0	67,5
9-5/8	53.50	69,0 (78,0)	— —	67,0 (67,0)	63,0 (63,0)	69,0 (78,0)
9-5/8	58.40	69,0 (85,0)	— —	67,0 (67,0)	63,0 (63,0)	— —
10-3/4	60.70	69,0 (70,0)	54,5 (54,5)	— —	51,5 (51,5)	69,0 (70,0)
10-3/4	65.70	69,0 (76,5)	54,5 (54,5)	— —	51,5 (51,5)	— —
11-3/4	60.00	57,5	46,0	—	43,5	—
11-3/4	65.00	62,5	—	—	—	—
11-3/4	71.00	68,5	—	—	—	—
13-3/8	72.00	53,0	36,0	—	34,0	—
16	109.00	56,5	—	—	—	—

NOTE Alternative test pressures are given in parentheses.

**Table C.55 — Hydrostatic test pressure for Grade H40 tubing**

Labels				Test pressure MPa					
1	2			Plain end	Non- upset T&C	External upset			Integral joint
	NU T&C	EU T&C	IJ			Regular coupling	Special- clearance coupling		
							H40	J55	
1	2	3	4	5	6	7	8	9	10
1.050	1.14	1.20	—	47,5	47,5	47,5	—	—	—
1.050	1.48	1.54	—	64,5	—	52,0	—	—	—
1.315	1.70	1.80	1.72	44,5	44,5	44,5	—	—	40,0
1.315	2.19	2.24	—	60,0	—	56,5	—	—	—
1.660	2.09	—	2.10	33,5	—	—	—	—	32,0
1.660	2.30	2.40	2.33	37,5	37,5	37,5	—	—	32,0
1.660	3.03	3.07	—	51,0	—	45,0	—	—	—
1.900	2.40	—	2.40	29,0	—	—	—	—	28,5
1.900	2.75	2.90	2.76	33,5	33,5	33,5	—	—	28,5
1.900	3.65	3.73	—	46,5	—	41,5	—	—	—
2.063	3.24	—	3.25	33,5	—	—	—	—	28,0
2.063	4.50	—	—	48,0	—	—	—	—	—
2-3/8	4.00	—	—	31,0	31,0	—	—	—	—
2-3/8	4.60	4.70	—	35,5	35,5	35,5	31,5	35,5	—
2-7/8	6.40	6.50	—	33,5	33,5	33,5	30,5	33,5	—
3-1/2	7.70	—	—	37,5	37,5	—	—	—	—
3-1/2	9.20	9.30	—	32,0	32,0	32,0	29,5	32,0	—
3-1/2	10.20	—	—	36,5	36,5	—	—	—	—
4	9.50	—	—	25,0	25,0	—	—	—	—
4	10.70	11.00	—	29,0	—	29,0	—	—	—
4-1/2	12.60	12.75	—	26,5	26,5	26,5	—	—	—

**Table C.56 — Hydrostatic test pressure for Grade J55 tubing**

Labels				Test pressure MPa					
1	2			Plain end	Non- upset T&C	External upset			Integral joint
	NU T&C	EU T&C	IJ			Regular coupling	Special- clearance coupling		
							J55	L80	
1	2	3	4	5	6	7	8	9	10
1.050	1.14	1.20	—	65,5	65,5	65,5	—	—	—
1.050	1.48	1.54	—	69,0	—	69,0	—	—	—
1.315	1.70	1.80	1.72	61,5	61,5	61,5	—	—	55,0
1.315	2.19	2.24	—	69,0	—	69,0	—	—	—
1.660	2.09	—	2.10	45,5	—	—	—	—	44,0
1.660	2.30	2.40	2.33	51,0	51,0	51,0	—	—	44,0
1.660	3.03	3.07	—	69,0	—	62,0	—	—	—
1.900	2.40	—	2.40	40,0	—	—	—	—	39,0
1.900	2.75	2.90	2.76	46,0	46,0	46,0	—	—	39,0
1.900	3.65	3.73	—	64,0	—	57,0	—	—	—
2.063	3.24	—	3.25	46,0	—	—	—	—	38,5
2.063	4.50	—	—	66,0	—	—	—	—	—
2-3/8	4.00	—	—	42,5	42,5	—	—	—	—
2-3/8	4.60	4.70	—	48,5	48,5	48,5	43,5	48,5	—
2-7/8	6.40	6.50	—	46,0	46,0	46,0	42,0	46,0	—
3-1/2	7.70	—	—	37,5	37,5	—	—	—	—
3-1/2	9.20	9.30	—	44,0	44,0	44,0	40,5	44,0	—
3-1/2	10.20	—	—	50,0	50,0	—	—	—	—
4	9.50	—	—	34,5	34,5	—	—	—	—
4	10.70	11.00	—	39,5	—	39,5	—	—	—
4-1/2	12.60	12.75	—	36,5	36,5	36,5	—	—	—



**Table C.57 — Hydrostatic test pressure for Grades N80 Type 1 and N80Q tubing**

Labels				Test pressure MPa					
1	2			Plain end	Non- upset T&C	External upset			Integral joint
	NU T&C	EU T&C	IJ			Regular coupling	Special- clearance coupling		
							N80	P110	
1	2	3	4	5	6	7	8	9	10
1.050	1.14	1.20	—	69,0	69,0	69,0	—	—	—
1.050	1.48	1.54	—	69,0	—	69,0	—	—	—
1.315	1.70	1.80	1.72	69,0	69,0	69,0	—	—	69,0
1.315	2.19	2.24	—	69,0	—	69,0	—	—	—
1.660	2.30	2.40	2.33	69,0	69,0	69,0	—	—	64,0
1.660	3.03	3.07	—	69,0	69,0	69,0	—	—	—
1.900	2.75	2.90	2.76	67,5	67,5	67,5	—	—	56,5
1.900	3.65	3.73	—	69,0	—	69,0	—	—	—
2.063	3.24	—	3.25	66,5	—	—	—	—	56,5
2.063	4.50	—	—	69,0	—	—	—	—	—
2-3/8	4.00	—	—	62,0	62,0	—	—	—	—
2-3/8	4.60	4.70	—	69,0	69,0	69,0	63,0	69,0	—
2-3/8	5.80	5.95	—	69,0	69,0	69,0	63,0	69,0	—
2-7/8	6.40	6.50	—	66,5	66,5	66,5	61,0	66,5	—
2-7/8	7.80	7.90	—	69,0	69,0	69,0	61,0	69,0	—
2-7/8	8.60	8.70	—	69,0	69,0	69,0	61,0	69,0	—
3-1/2	7.70	—	—	54,5	54,5	—	—	—	—
3-1/2	9.20	9.30	—	64,0	64,0	64,0	59,0	64,0	—
3-1/2	10.20	—	—	69,0	69,0	—	—	—	—
3-1/2	12.70	12.95	—	69,0	69,0	69,0	59,0	69,0	—
4	9.50	—	—	50,0	50,0	—	—	—	—
4	10.70	11.00	—	58,0	—	58,0	—	—	—
4-1/2	12.60	12.75	—	53,0	53,0	53,0	—	—	—

**Table C.58 — Hydrostatic test pressure for Grade L80 tubing**

Labels				Test pressure MPa				
1	2			Plain end	Non- upset T&C	External upset		Integral joint
	NU T&C	EU T&C	IJ			Regular coupling	Special- clearance coupling	
1	2	3	4	5	6	7	8	9
1.050	1.14	1.20	—	69,0	69,0	69,0	—	—
1.050	1.48	1.54	—	69,0	—	69,0	—	—
1.315	1.70	1.80	1.72	69,0	69,0	69,0	—	69,0
1.315	2.19	2.24	—	69,0	—	69,0	—	—
1.660	2.30	2.40	2.33	69,0	69,0	69,0	—	64,0
1.660	3.03	3.07	—	69,0	—	69,0	—	—
1.900	2.75	2.90	2.76	67,5	67,5	67,5	—	56,5
1.900	3.65	3.73	—	69,0	—	69,0	—	—
1.900	4.42	—	—	69,0	—	—	—	—
1.900	5.15	—	—	69,0	—	—	—	—
2.063	3.24	—	3.25	66,5	—	—	—	56,5
2.063	4.50	—	—	69,0	—	—	—	—
2-3/8	4.00	—	—	62,0	62,0	—	—	—
2-3/8	4.60	4.70	—	69,0	69,0	69,0	63,0	—
2-3/8	5.80	5.95	—	69,0	69,0	69,0	63,0	—
2-3/8	6.60	—	—	69,0	—	—	—	—
2-3/8	7.35	7.45	—	69,0	—	69,0	63,0	—
2-7/8	6.40	6.50	—	66,5	66,5	66,5	61,0	—
2-7/8	7.80	7.90	—	69,0	69,0	69,0	61,0	—
2-7/8	8.60	8.70	—	69,0	69,0	69,0	61,0	—
2-7/8	9.35	9.45	—	69,0	—	69,0	61,0	—
2-7/8	10.50	—	—	69,0	—	—	—	—
2-7/8	11.50	—	—	69,0	—	—	—	—
3-1/2	7.70	—	—	54,5	54,5	—	—	—
3-1/2	9.20	9.30	—	64,0	64,0	64,0	59,0	—
3-1/2	10.20	—	—	69,0	69,0	—	—	—
3-1/2	12.70	12.95	—	69,0	69,0	69,0	59,0	—
3-1/2	14.30	—	—	69,0	—	—	—	—
3-1/2	15.50	—	—	69,0	—	69,0	—	—
3-1/2	17.00	—	—	69,0	—	—	—	—
4	9.50	—	—	50,0	50,0	—	—	—
4	10.70	11.00	—	58,0	—	58,0	—	—
4	13.20	—	—	69,0	—	—	—	—
4	16.10	—	—	69,0	—	—	—	—
4	18.90	—	—	69,0	—	—	—	—
4	22.20	—	—	69,0	—	—	—	—
4-1/2	12.60	12.75	—	53,0	53,0	53,0	—	—
4-1/2	15.20	—	—	66,0	—	—	—	—
4-1/2	17.00	—	—	69,0	—	—	—	—
4-1/2	18.90	—	—	69,0	—	—	—	—
4-1/2	21.50	—	—	69,0	—	—	—	—
4-1/2	23.70	—	—	69,0	—	—	—	—
4-1/2	26.10	—	—	69,0	—	—	—	—

**Table C.59 — Hydrostatic test pressure for Grade C90 tubing**

Labels				Test pressure MPa			
1	2			Plain end	Non-upset T&C	External upset regular coupling	Integral joint
	NU T&C	EU T&C	IJ				
1	2	3	4	5	6	7	8
1.050	1.14	1.20	—	69,0	69,0	69,0	—
1.050	1.48	1.54	—	69,0	—	69,0	—
1.315	1.70	1.80	1.72	69,0	69,0	69,0	69,0
1.315	2.19	2.24	—	69,0	—	69,0	—
1.660	2.30	2.40	2.33	69,0	69,0	69,0	69,0
1.660	3.03	3.07	—	69,0	—	69,0	—
1.900	2.75	2.90	2.76	69,0	69,0	69,0	64,0
1.900	3.65	3.73	—	69,0	—	69,0	—
1.900	4.42	—	—	69,0	—	—	—
1.900	5.15	—	—	69,0	—	—	—
2.063	3.24	—	3.25	69,0	—	—	63,5
2.063	4.50	—	—	69,0	—	—	—
2-3/8	4.00	—	—	69,0	69,0	—	—
2-3/8	4.60	4.70	—	69,0	69,0	69,0	—
2-3/8	5.80	5.95	—	69,0	69,0	69,0	—
2-3/8	6,60	—	—	69,0	—	—	—
2-3/8	7.35	7.45	—	69,0	—	69,0	—
2-7/8	6.40	6.50	—	69,0	69,0	69,0	—
2-7/8	7.80	7.90	—	69,0	69,0	69,0	—
2-7/8	8.60	8.70	—	69,0	69,0	69,0	—
2-7/8	9.35	9.45	—	69,0	—	69,0	—
2-7/8	10.50	—	—	69,0	—	—	—
2-7/8	11.50	—	—	69,0	—	—	—
3-1/2	7.70	—	—	61,5	61,5	—	—
3-1/2	9.20	9.30	—	69,0	69,0	69,0	—
3-1/2	10.20	—	—	69,0	69,0	—	—
3-1/2	12.70	12.95	—	69,0	69,0	69,0	—
3-1/2	14.30	—	—	69,0	—	—	—
3-1/2	15.50	—	—	69,0	—	—	—
3-1/2	17.00	—	—	69,0	—	—	—
4	9.50	—	—	56,0	56,0	—	—
4	10.70	11.00	—	65,0	—	65,0	—
4	13.20	—	—	69,0	—	—	—
4	16.10	—	—	69,0	—	—	—
4	18.90	—	—	69,0	—	—	—
4	22.20	—	—	69,0	—	—	—
4-1/2	12.60	12.75	—	60,0	60,0	60,0	—
4-1/2	15.20	—	—	69,0	—	—	—
4-1/2	17.00	—	—	69,0	—	—	—
4-1/2	18.90	—	—	69,0	—	—	—
4-1/2	21.50	—	—	69,0	—	—	—
4-1/2	23.70	—	—	69,0	—	—	—
4-1/2	26.10	—	—	69,0	—	—	—

**Table C.60 — Hydrostatic test pressure for Grade T95 tubing**

Labels				Test pressure MPa			
1	2			Plain end	Non-upset T&C	External upset regular coupling	Integral joint
	NU T&C	EU T&C	IJ				
1	2	3	4	5	6	7	8
1.050	1.14	1.20	—	69,0	69,0	69,0	—
1.050	1.48	1.54	—	69,0	—	69,0	—
1.315	1.70	1.80	1.72	69,0	69,0	69,0	69,0
1.315	2.19	2.24	—	69,0	—	69,0	—
1.660	2.30	2.40	2.33	69,0	69,0	69,0	69,0
1.660	3.03	3.07	—	69,0	—	69,0	—
1.900	2.75	2.90	2.76	69,0	69,0	69,0	67,5
1.900	3.65	3.73	—	69,0	—	69,0	—
1.900	4.42	—	—	69,0	—	—	—
1.900	5.15	—	—	69,0	—	—	—
2.063	3.24	—	3.25	69,0	—	—	67,0
2.063	4.50	—	—	69,0	—	—	—
2-3/8	4.00	—	—	69,0	69,0	—	—
2-3/8	4.60	4.70	—	69,0	69,0	69,0	—
2-3/8	5.80	5.95	—	69,0	69,0	69,0	—
2-3/8	6.60	—	—	69,0	—	—	—
2-3/8	7.35	7.45	—	69,0	—	69,0	—
2-7/8	6.40	6.50	—	69,0	69,0	69,0	—
2-7/8	7.80	7.90	—	69,0	69,0	69,0	—
2-7/8	8.60	8.70	—	69,0	69,0	69,0	—
2-7/8	9.35	9.45	—	69,0	—	69,0	—
2-7/8	10.50	—	—	69,0	—	—	—
2-7/8	11.50	—	—	69,0	—	—	—
3-1/2	7.70	—	—	64,5	64,5	—	—
3-1/2	9.20	9.30	—	69,0	69,0	69,0	—
3-1/2	10.20	—	—	69,0	69,0	—	—
3-1/2	12.70	12.95	—	69,0	69,0	69,0	—
3-1/2	14.30	—	—	69,0	—	—	—
3-1/2	15.50	—	—	69,0	—	—	—
3-1/2	17.00	—	—	69,0	—	—	—
4	9.50	—	—	59,0	59,0	—	—
4	10.70	11.00	—	68,5	—	68,5	—
4	13.20	—	—	69,0	—	—	—
4	16.10	—	—	69,0	—	—	—
4	18.90	—	—	69,0	—	—	—
4	22.20	—	—	69,0	—	—	—
4-1/2	12.60	12.75	—	63,0	63,0	63,0	—
4-1/2	15.20	—	—	69,0	—	—	—
4-1/2	17.00	—	—	69,0	—	—	—
4-1/2	18.90	—	—	69,0	—	—	—
4-1/2	21.50	—	—	69,0	—	—	—
4-1/2	23.70	—	—	69,0	—	—	—
4-1/2	26.10	—	—	69,0	—	—	—

**Table C.61 — Hydrostatic test pressure for Grade P110 tubing**

Labels			Test pressure MPa			
			Plain end	Non-upset T&C	External upset	
1	2				Regular coupling	Special- clearance coupling
	NU T&C	EU T&C				
1	2	3	4	5	6	7
1.050	1.48	1.54	69,0 (178,0)	— —	69,0 (142,5)	— —
1.315	2.19	2.24	69,0 (165,0)	— —	69,0 (154,5)	— —
1.660	3.03	3.07	69,0 (139,5)	— —	69,0 (123,5)	— —
1.900	2.75	2.90	69,0 (92,5)	— —	69,0 (92,5)	— —
2.063	4.50	—	69,0 (132,5)	— —	— —	— —
2-3/8	4.60	4.70	69,0 (97,0)	69,0 (97,0)	69,0 (97,0)	69,0 (86,5)
2-3/8	5.80	5.95	69,0 (129,5)	69,0 (121,5)	69,0 (112,5)	69,0 (86,5)
2-7/8	6.40	6.50	69,0 (91,5)	69,0 (91,5)	69,0 (91,5)	69,0 (83,5)
2-7/8	7.80	7.90	69,0 (116,5)	69,0 (116,5)	69,0 (113,5)	69,0 (83,5)
2-7/8	8.60	8.70	69,0 (130,0)	69,0 (126,5)	69,0 (113,5)	69,0 (83,5)
3-1/2	9.20	9.30	69,0 (88,0)	69,0 (88,0)	69,0 (88,0)	69,0 (81,0)
3-1/2	12.70	12.95	69,0 (130,0)	69,0 (124,0)	69,0 (118,0)	69,0 (81,0)

NOTE Alternative test pressures are given in parentheses.

**Table C.62 — Summary of NDE methods for seamless pipe, coupling stock and the body of welded pipe**

Grade	Visual inspection (see 10.14)	Wall thickness determination	Ultrasonic inspection	Flux leakage inspection	Eddy current inspection	Magnetic particle inspection <sup>a</sup>
1	2	3	4	5	6	7
H40, J55 K55, N80 Type 1	R	N	N	N	N	N
N80Q, L80 C95, M65	R	R	A	A	A	A
P110	R	R	A	A	A	NA
C90, T95, Q125	R	R	C	B	B	B
Coupling stock – H40, J55, K55, N80 Type 1	R	NA	N	N	N	N
Coupling stock – N80Q, L80, C95, P110, C90, T95, Q125	R	R	A	A	A	A

N = not required  
R = required  
A = one method or any combination of methods shall be used  
B = at least one method shall be used in addition to ultrasonic inspection to inspect the outside surface  
C = ultrasonic inspection shall be used to inspect the outside and inside surfaces  
NA = not applicable

<sup>a</sup> MPI is permitted for end-area inspection. MPI is permitted for pipe body outside-surface inspection in combination with other methods of pipe body inspection. MPI is permitted for coupling stock outside surface inspection. Coupling stock receiving full length MPI does not require full length wall thickness determination, however, mechanical wall thickness measurement of each end is required.

**Table C.63 — Acceptance (inspection) levels**

Grade	External imperfection		Internal imperfection	
	Longitudinal	Transverse	Longitudinal	Transverse
1	2	3	4	5
<b>Pipe</b>				
N80Q, M65, L80, C95	L4	—	L4	—
P110 to A.10 (SR16)	L4	L4	L4	L4
P110	L2	L2	L2	L2
P110 to A.10 (SR16) and A.3 (SR2)	L2	L2	L2	L2
C90, T95, Q125	UT	L2	L2	L2
	2 <sup>nd</sup> method	L2	L2	—
<b>Weld seam</b>				
P110, Q125	L2	N	L2	N
All other grades	L3	N	L3	N
<b>Coupling stock</b>	L2	L2	N	N

N = not required; Lx = acceptance (inspection) level.

**Table C.64 — Artificial reference indicators**

Acceptance (inspection) level	Notch depth <sup>a</sup> max. %	Notch length max. at full depth mm	Width max. mm	Radially drilled hole diameter <sup>b</sup> mm
1	2	3	4	5
L2	5	50	1	1,6
L3	10	50	1	3,2
L4	12,5	50	1	3,2

NOTE See Figure D.17.

<sup>a</sup> Depth as a percent of specified wall thickness. The depth tolerance shall be  $\pm 15\%$  of the calculated notch depth with a minimum notch depth of  $0,3\text{ mm} \pm 0,05\text{ mm}$ .

<sup>b</sup> Drilled hole diameter (through the pipe wall) shall be based on the drill bit size.

**Table C.65 — Size of stamp markings**

Product	Label 1	Marking height mm
Pipe	< 4-1/2	4,8
	$\geq 4-1/2$	6,4
Coupling	For pipe sizes < 4-1/2	6,4
	For pipe sizes $\geq 4-1/2$ to < 7-5/8	9,5
	For pipe sizes $\geq 7-5/8$	12,7

**Table C.66 — Grade colour codes**

Grade	Grade type	Number and colour of bands for pipe, coupling stock and pup joints $\geq 1,8$ m	Colour(s) for couplings	
			Entire coupling	Band(s) <sup>a</sup>
1	2	3	4	5
H40		None or black band at the manufacturer's option	None	Same as for pipe
J55 tubing		One bright green	Bright green	None
J55 casing		One bright green	Bright green	One white
K55		Two bright green	Bright green	None
M65		One bright green, one blue	M65 pipe uses L80 Type 1 couplings	
N80	1	One red	Red	None
N80	Q	One red, one bright green	Red	Green
L80	1	One red, one brown	Red	One brown
L80	9Cr	One red, one brown, two yellow	Red	Two yellow
L80	13Cr	One red, one brown, one yellow	Red	One yellow
C90	1	One purple	Purple	None
C90	2	One purple, one yellow	Purple	One yellow
T95	1	One silver	Silver	None
T95	2	One silver, one yellow	Silver	One yellow
C95		One brown	Brown	None
P110		One white	White	None
Q125	1	One orange	Orange	None
Q125	2	One orange, one yellow	Orange	One yellow
Q125	3	One orange, one green	Orange	One green
Q125	4	One orange, one brown	Orange	One brown

<sup>a</sup> Special-clearance couplings shall also have a black band.

**Table C.67 — Thread type markings**

Product	Thread type	Marked symbol
Casing	Short round	STC
	Long round	LC
	Buttress	BC
	Extreme-line	XC
Tubing	Non-upset	NU
	External upset	EU
	Integral joint	IJ



**Table C.68 — Marking requirements and sequence**

1	Marking sequence	Mark or symbol <sup>b</sup>	Stencil and/or stamp marking requirements <sup>a</sup>				
			Groups 1 and 3		Groups 2 and 4		All groups
			Pipe and pup joints	Couplings and accessories	Pipe and pup joints	Couplings and accessories	Coupling stock
2	3	4	5	6	7	8	
1	Manufacturer's name or mark	« ..... »	D or P	D or P	P	P	P
2	ISO 11960	ISO 11960	D or P	D or P	P	P	P
	Marking to indicate API 5CT is at manufacturer's option or as specified on purchase agreement.	5CT <sup>c</sup>	D or P	D or P	P	P	P
	Date of manufacture as in 11.1.8 or 11.1.9.	« ..... »	D or P	D or P	P	P	P
3	Unthreaded pipe or special end-finish, if applicable (place symbol after specification marking):						
	— Unthreaded pipe either upset or non-upset	UF	D or P		P		
	— Pipe with special end-finish threaded by the pipe mill or processor	SF	D or P		P		
	— Completed couplings or completed accessories threaded with special end-finish	SF		D or P		P	
— Coupling stock identification	CS					P	
4	Size designation (fill in Label 1 designation from column 1 of Table C.1, C.2 or C.3) Specified diameter for coupling stock	« ..... »	P		P		P
5	Mass designation (fill in Label 2 designation from column 2 of Table C.1, C.2 or C.3) Specified wall thickness for coupling stock	« ..... »	D or P		P		P
6	Grade of pipe:						
	— H40	H					
	— J55	J					
	— K55	K					
	— M65	M					
	— N80 Type 1	N1					
	— N80Q	NQ					
	— L80 Type 1	L					
	— L80 Type9Cr	L9					
	— L80 Type13Cr	L13					
	— C90 Type1	C90-1					
	— C90 Type2	C90-2					
	— C95	C					
	— T95 Type1	T95-1					
	— T95 Type2	T95-2					
	— P110	P					
— Q125 Type1	Q1						
— Q125 Type2	Q2						
— Q125 Type3	Q3						
— Q125 Type4	Q4						
All grade designations		D or P	D or P	P	P	P	
7	Reduced alternative impact test temperature, if applicable. Fill in specified test temperature for full-size specimens, including ± symbol and °C	« ... »C	P	P	P	P	
8	Heat treatment, if applicable:						
	— J55, K55 or M65 normalized	Z	P	P	P	P	P
— J55, K55 or M65 quenched and tempered	Q	P	P	P	P	P	

Table C.68 (continued)

1	Marking sequence	Mark or symbol <sup>b</sup>	Stencil and/or stamp marking requirements <sup>a</sup>				
			Groups 1 and 3		Groups 2 and 4		All groups
			Pipe and pup joints	Couplings and accessories	Pipe and pup joints	Couplings and accessories	Coupling stock
2	3	4	5	6	7	8	
9	Process of manufacture: — Seamless — Electric-welded All designations	S E	D or P		P		
10	Supplementary requirements, if applicable: — A.2 (SR1) — A.3 (SR2) — A.4 (SR9) (fill in type) — A.8 (SR13) — A.10 (SR16) (fill in minimum full-size energy absorption requirement, in joules, and test temperature including ± symbol and °C) — A.11 (SR22) — Annex H (PSL)	S1 S2 S9Q« .. » S13 S16« ... »C S22 L2 or L3	P P D or P P P P		P P P P P P	P P	P
11	Hydrostatic test pressure <sup>e</sup> (fill in the actual test pressure, in MPa) All designations	P« ..... »	P		P		
12	Type of thread, if applicable: — For manufacturers, processors or threaders of casing buttress, extreme-line or round threads (fill in type of thread from Table C.67) — For threaders of tubing threads (fill in type of thread from Table C.67)	« ..... » « ..... »	P P		P P		
13	Full-length drift test, if applicable: — Standard (casing or tubing) — Alternative (casing or tubing) where « » is the size of the alternative drift — For casing specified for tubing service and drift-tested in accordance with 8.10 All designations	D DA« ..... » DT42	P		P		
14	Serialization of Grades C90, T95 and Q125				D <sup>d</sup> or P	D <sup>d</sup> or P	P
15	Tin plating of couplings, if applicable	T		P		P	
16	Couplings H40, J55 and K55 only visually inspected	V		P			

NOTE See 11.4 for mandatory colour code requirements.

<sup>a</sup> D indicates optional (die) stamping (for location see 11.2.3); P indicates a requirement for (paint) stencilling (for location see 11.3). Additional marking is permitted as specified in 11.1.10.

<sup>b</sup> A blank space, « ..... », indicates information to be filled in.

<sup>c</sup> The manufacturer may include "API" before "5CT".

<sup>d</sup> Stamp marking shall conform to the requirements of 11.2.5.

<sup>e</sup> Pipe can be identified as manufactured to SI units by the marked hydro-test pressure which will be less than 100 (MPa), while the pressure marked for pipe manufactured to USC units will be over 1 000 (psi). This information is used to clearly identify the units used for CVN markings, which shall be in the same unit system as the pressure markings.

**Table C.69 — Retention of records**

Requirement	Subclause reference
<b>Chemical properties</b>	
Heat analysis	10.3.2
Product analysis	10.3.3
<b>Mechanical properties</b>	
Tensile tests	7.2, 10.4.7
Control tests	10.4.2
Impact tests	7.4, 7.5, 7.6, 10.7
Couplings	9.5
Hardness tests	7.7, 7.8, 7.9 and 10.6
Hardenability test (Grades C90 and T95)	7.10, 10.9
Grain size (Grades C90 and T95)	7.11, 10.8
<b>Hydrostatic tests</b>	
Tester recorder charts	10.12.1
Testing	10.12.1
<b>Manufacturer certification</b>	
Results of all required tests (Group 4)	13.3
Sulfide stress-cracking test (Grades C90 and T95)	7.14, 10.10
Calibration	Various

**Table C.70 — SR11.1 Distance between plates for flattening tests**

Grade	$D/t$ ratio	Distance between plates mm max.
P110	All ratios	$D \times (1,086 - 0,0163 D/t)$
Q125	All ratios	$D \times (1,092 - 0,0140 D/t)$

$D$  is the specified outside diameter of pipe, in millimetres.  
 $t$  is the specified wall thickness of the pipe, in millimetres.

**Table C.71 — SR12.1 Inspection lot sample sizes vs.  $F$  factor**

Sample size	$F$	Sample size	$F$
1	2	3	4
3	13,857	16	4,534
4	9,215	18	4,415
5	7,501	20	4,319
6	6,612	25	4,143
7	6,061	30	4,022
8	5,686	35	3,937
9	5,414	40	3,866
10	5,203	45	3,811
12	4,900	50	3,766
14	4,690	$\infty$	3,090

**Table C.72 — SR12.2 Probability of defective pipes**

Probability of one length being defective	Probability that one or more defective lengths is included in a string of 100 pipes
1/10	0,999 97 (or 100 %)
1/100	0,634 (or 63 %)
1/1 000	0,095 (or 10 %)
1/10 000	0,009 95 (or 1 %)

**Table C.73 — SR16.1 Transverse impact specimen size required**

Label 1	Calculated wall thickness required to machine transverse Charpy impact specimens mm		
	Full-size	¾-size	½-size
1	2	3	4
3-1/2	20,53	18,03	15,53
4	19,09	16,59	14,09
4-1/2	18,05	15,55	13,05
5	17,26	14,76	12,26
5-1/2	16,64	14,14	11,64
6-5/8	15,62	13,12	10,62
7	15,36	12,86	10,36
7-5/8	14,99	12,49	9,99
7-3/4	14,92	12,42	9,92
8-5/8	14,51	12,01	9,51
9-5/8	14,13	11,63	9,13
10-3/4	13,80	11,30	8,80
11-3/4	13,56	11,06	8,56
13-3/8	13,24	10,74	8,24
16	12,87	10,37	7,87
18-5/8	12,60	10,10	7,60
20	12,49	9,99	7,49

NOTE The wall thicknesses in columns 2, 3 and 4 that are in excess of the maximum wall thicknesses for ISO/API pipe are for information only. The above provides a 0,50 mm ID and a 0,50 mm OD machining allowance.

**Table C.74 — SR16.2 Longitudinal impact specimen size required**

Label 1	Calculated wall thickness required to machine longitudinal Charpy impact specimens mm		
	Full-size	¾-size	½-size
1	2	3	4
1.050	11,97	9,47	6,97
1.315	11,77	9,27	6,77
1.660	11,60	9,10	6,60
1.900	11,52	9,02	6,52
2.063	11,48	8,98	6,48
2-3/8	11,42	8,92	6,42
2-7/8	11,34	8,84	6,34
3-1/2	11,28	8,78	6,28
4	11,25	8,75	6,25
4-1/2	11,22	8,72	6,22
5	11,20	8,70	6,20
5-1/2	11,18	8,68	6,18
6-5/8	11,15	8,65	6,15
7	11,14	8,64	6,14
7-5/8	11,13	8,63	6,13
7-3/4	11,13	8,63	6,13
8-5/8	11,11	8,61	6,11
9-5/8	11,10	8,60	6,10
10-3/4	11,09	8,59	6,09
11-3/4	11,08	8,58	6,08
13-3/8	11,07	8,57	6,07
16	11,06	8,56	6,06
18-5/8	11,05	8,55	6,05
20	11,05	8,55	6,05

NOTE The wall thicknesses in columns 2, 3 and 4 that are in excess of the maximum wall thicknesses for ISO/API pipe are for information only. The above provides a 0,50 mm ID and a 0,50 mm OD machining allowance.

**Table C.75 — SR16.3 Acceptable size impact specimens and absorbed energy reduction factor**

Test specimen size	Specimen dimensions mm	Reduction factor
Full-size	10,0 × 10,0	1,00
¾-size	10,0 × 7,5	0,80
½-size	10,0 × 5,0	0,55

**Table C.76 — SR16.4 Hierarchy of test specimen orientation and size**

Choice	Orientation	Size
1 <sup>st</sup>	Transverse	Full-size
2 <sup>nd</sup>	Transverse	¾-size
3 <sup>rd</sup>	Transverse	½-size
4 <sup>th</sup>	Longitudinal	Full-size
5 <sup>th</sup>	Longitudinal	¾-size
6 <sup>th</sup>	Longitudinal	½-size

**Table C.77 — SR16.5 Transverse Charpy absorbed energy requirements — Grade N80 Type 1**

Maximum specified wall thickness mm	Minimum transverse absorbed energy J
11,59	14
13,12	15
14,66	16
16,19	17
17,73	18
19,26	19
20,80	20
22,33	21
23,87	22
25,40	23
26,94	24

For wall thicknesses greater than shown above, the requirements shall be according to the equations for the wall thickness and grade.

NOTE Wall thicknesses greater than those of standard ISO/API pipe are shown here for information for special applications.

**Table C.78 — SR16.6 Longitudinal Charpy absorbed energy requirements — Grade N80 Type 1**

Maximum specified wall thickness mm	Minimum longitudinal absorbed energy J
10,44	27
11,20	28
11,97	29
12,74	30
13,51	31
14,27	32
15,04	33
15,81	34
16,58	35
17,34	36
18,11	37
18,88	38
19,65	39
20,41	40
21,18	41
21,95	42
22,72	43
23,48	44
24,25	45
25,02	46
25,79	47

For wall thicknesses greater than shown above, the requirements shall be according to the equations for the wall thickness and grade.

NOTE Wall thicknesses greater than those of standard ISO/API pipe are shown here for information for special applications.

**Table C.79 — SR16.7 Test temperature reduction for sub-size specimens — Grades H40, J55 and K55 only**

Specimen size mm	Specified pipe wall thickness mm	Temperature reduction °C
10,0 × 7,5	> 10,0	3
10,0 × 5,0	> 10,0	11
10,0 × 5,0	7,5 to 10,0	8
10,0 × 5,0	6,7 to 7,4	6
10,0 × 5,0	6,0 to 6,6	3

Table C.80 — SR22-1

Label 1	Label 2	Grade <sup>a</sup>	Outside dia. <i>D</i>	Drift	Coupling OD regular <i>W</i>	Power turns min.	Length <sup>b</sup> <i>L<sub>g</sub></i>	Approx. start torque		Recommended thread compound mass <sup>c</sup>
								Tin N·m	Phosphate N·m	
1	2	3	4	5	6	7	8	9	10	11
4-1/2	11.60	J/K55	114,30	98,42	127,00	3	82,55	176	294	15
4-1/2	11.60	L/N80	114,30	98,42	127,00	3	82,55	168	279	15
4-1/2	13.50	L/N80	114,30	96,38	127,00	3	82,55	184	308	15
4-1/2	11.60	C90	114,30	98,42	127,00	3	82,55	172	—	15
4-1/2	13.50	C90	114,30	96,38	127,00	3	82,55	194	—	15
4-1/2	11.60	C/T95	114,30	98,42	127,00	3	82,55	176	—	15
4-1/2	13.50	C/T95	114,30	96,38	127,00	3	82,55	198	—	15
4-1/2	11.60	P110	114,30	98,42	127,00	3	82,55	176	—	15
4-1/2	13.50	P110	114,30	96,38	127,00	3	82,55	201	—	15
5	13.00	J/K55	127,00	110,96	141,30	3	92,08	157	262	20
5	15.00	J/K55	127,00	108,78	141,30	3	92,08	169	282	20
5	15.00	L/N80	127,00	108,78	141,30	3,5	92,08	222	370	20
5	18.00	L/N80	127,00	105,44	141,30	3,5	92,08	298	498	20
5	15.00	C90	127,00	108,78	141,30	3	92,08	268	—	20
5	18.00	C90	127,00	105,44	141,30	3	92,08	323	—	20
5	15.00	C/T95	127,00	108,78	141,30	3,5	92,08	274	—	20
5	18.00	C/T95	127,00	105,44	141,30	3,5	92,08	329	—	20
5	15.00	P110	127,00	108,78	141,30	3,5	92,08	282	—	20
5	18.00	P110	127,00	105,44	141,30	3,5	92,08	336	—	20
5-1/2	15.50	J/K55	139,70	122,56	153,67	3	95,25	220	366	25
5-1/2	17.00	J/K55	139,70	121,08	153,67	3	95,25	260	434	25
5-1/2	17.00	L/N80	139,70	121,08	153,67	4	95,25	325	542	25
5-1/2	20.00	L/N80	139,70	118,18	153,67	4	95,25	370	618	25
5-1/2	17.00	C90	139,70	121,08	153,67	3	95,25	244	—	25
5-1/2	20.00	C90	139,70	118,18	153,67	3	95,25	278	—	25
5-1/2	17.00	C/T95	139,70	121,08	153,67	3,5	95,25	301	—	25
5-1/2	20.00	C/T95	139,70	118,18	153,67	3,5	95,25	340	—	25
5-1/2	17.00	P110	139,70	121,08	153,67	4	95,25	366	—	25
5-1/2	20.00	P110	139,70	118,18	153,67	4	95,25	408	—	25
6-5/8	20.00	J/K55	168,28	150,46	187,71	3	104,78	220	365	30
6-5/8	24.00	J/K55	168,28	147,22	187,71	3	104,78	274	457	30
6-5/8	24.00	L/N80	168,28	147,22	187,71	4	104,78	450	751	30
6-5/8	28.00	L/N80	168,28	143,92	187,71	4	104,78	525	876	30
6-5/8	32.00	L/N80	168,28	140,98	187,71	4	104,78	579	965	30
6-5/8	24.00	C90	168,28	147,22	187,71	4	104,78	476	—	30
6-5/8	28.00	C90	168,28	143,92	187,71	4	104,78	553	—	30
6-5/8	32.00	C90	168,28	140,98	187,71	4	104,78	611	—	30
6-5/8	24.00	C/T95	168,28	147,22	187,71	4	104,78	483	—	30
6-5/8	28.00	C/T95	168,28	143,92	187,71	4	104,78	557	—	30
6-5/8	32.00	C/T95	168,28	140,98	187,71	4	104,78	614	—	30
6-5/8	24.00	P110	168,28	147,22	187,71	4,5	104,78	565	—	30
6-5/8	28.00	P110	168,28	143,92	187,71	4,5	104,78	655	—	30
6-5/8	32.00	P110	168,28	140,98	187,71	4,5	104,78	721	—	30

Table C.80 (continued)

Label 1	Label 2	Grade <sup>a</sup>	Outside dia. <i>D</i>	Drift	Coupling OD regular <i>W</i>	Power turns min.	Length <sup>b</sup> <i>L<sub>g</sub></i>	Approx. start torque		Recommended thread compound mass <sup>c</sup>
								Tin N·m	Phosphate N·m	
1	2	3	4 mm	5 mm	6 mm	7 N	8 mm	9 N·m	10 N·m	11 g
7	23.00	J/K55	177,80	158,52	194,46	4	107,95	321	536	35
7	26.00	J/K55	177,80	156,24	194,46	4	107,95	370	617	35
7	23.00	L/N80	177,80	158,52	194,46	5,5	107,95	561	936	35
7	26.00	L/N80	177,80	156,24	194,46	5,5	107,95	659	1098	35
7	29.00	L/N80	177,80	153,90	194,46	5,5	107,95	736	1226	35
7	32.00	L/N80	177,80	151,61	194,46	5,5	107,95	793	1322	35
7	23.00	C90	177,80	158,52	194,46	4,5	107,95	480	—	35
7	26.00	C90	177,80	156,24	194,46	4,5	107,95	548	—	35
7	29.00	C90	177,80	153,90	194,46	4,5	107,95	609	—	35
7	32.00	C90	177,80	151,61	194,46	4,5	107,95	663	—	35
7	23.00	C/T95	177,80	158,52	194,46	4,5	107,95	489	—	35
7	26.00	C/T95	177,80	156,24	194,46	4,5	107,95	556	—	35
7	29.00	C/T95	177,80	153,90	194,46	4,5	107,95	617	—	35
7	32.00	C/T95	177,80	151,61	194,46	4,5	107,95	670	—	35
7	26.00	P110	177,80	156,24	194,46	5	107,95	643	—	35
7	29.00	P110	177,80	153,90	194,46	5	107,95	712	—	35
7	32.00	P110	177,80	151,61	194,46	5	107,95	769	—	35
7-5/8	26.40	J/K55	193,68	173,84	215,90	3,5	111,12	331	550	40
7-5/8	26.40	L/N80	193,68	173,84	215,90	5	111,12	654	1090	40
7-5/8	29.70	L/N80	193,68	171,46	215,90	5	111,12	767	1279	40
7-5/8	33.70	L/N80	193,68	168,66	215,90	5	111,12	880	1466	40
7-5/8	39.00	L/N80	193,68	165,10	215,90	5	111,12	999	1665	40
7-5/8	26.40	C90	193,68	173,84	215,90	4,5	111,12	555	—	40
7-5/8	29.70	C90	193,68	171,46	215,90	4,5	111,12	637	—	40
7-5/8	33.70	C90	193,68	168,66	215,90	4,5	111,12	721	—	40
7-5/8	39.00	C90	193,68	165,10	215,90	4,5	111,12	813	—	40
7-5/8	26.40	C/T95	193,68	173,84	215,90	4,5	111,12	565	—	40
7-5/8	29.70	C/T95	193,68	171,46	215,90	4,5	111,12	645	—	40
7-5/8	33.70	C/T95	193,68	168,66	215,90	4,5	111,12	728	—	40
7-5/8	39.00	C/T95	193,68	165,10	215,90	4,5	111,12	818	—	40
7-5/8	29.70	P110	193,68	171,46	215,90	5	111,12	747	—	40
7-5/8	33.70	P110	193,68	168,66	215,90	5	111,12	841	—	40
7-5/8	39.00	P110	193,68	165,10	215,90	5	111,12	942	—	40
8-5/8	32.00	J/K55	219,08	198,02	244,48	3,5	120,65	415	691	50
8-5/8	36.00	J/K55	219,08	195,58	244,48	3,5	120,65	483	804	50
8-5/8	36.00	L/N80	219,08	195,58	244,48	5,5	120,65	832	1388	50
8-5/8	40.00	L/N80	219,08	193,04	244,48	5,5	120,65	891	1485	50
8-5/8	44.00	L/N80	219,08	190,50	244,48	5,5	120,65	999	1666	50
8-5/8	49.00	L/N80	219,08	187,60	244,48	5,5	120,65	1079	1798	50
8-5/8	36.00	C90	219,08	195,58	244,48	4,5	120,65	881	—	50
8-5/8	40.00	C90	219,08	193,04	244,48	4,5	120,65	980	—	50
8-5/8	44.00	C90	219,08	190,50	244,48	4,5	120,65	1070	—	50
8-5/8	49.00	C90	219,08	187,60	244,48	4,5	120,65	1162	—	50
8-5/8	36.00	C/T95	219,08	195,58	244,48	5	120,65	936	—	50
8-5/8	40.00	C/T95	219,08	193,04	244,48	5	120,65	1047	—	50
8-5/8	44.00	C/T95	219,08	190,50	244,48	5	120,65	1143	—	50
8-5/8	49.00	C/T95	219,08	187,60	244,48	5	120,65	1239	—	50
8-5/8	40.00	P110	219,08	193,04	244,48	5,5	120,65	1083	—	50
8-5/8	44.00	P110	219,08	190,50	244,48	5,5	120,65	1222	—	50
8-5/8	49.00	P110	219,08	187,60	244,48	5,5	120,65	1322	—	50



Table C.80 (continued)

Label 1	Label 2	Grade <sup>a</sup>	Outside dia. <i>D</i> mm	Drift mm	Coupling OD regular <i>W</i> mm	Power turns min. N	Length <sup>b</sup> <i>L<sub>g</sub></i> mm	Approx. start torque		Recommended thread compound mass <sup>c</sup> g
								Tin N·m	Phosphate N·m	
1	2	3	4	5	6	7	8	9	10	11
9-5/8	36.00	J/K55	244,48	222,63	269,88	3,5	127,00	533	687	55
9-5/8	40.00	J/K55	244,48	220,45	269,88	3,5	127,00	595	776	55
9-5/8	40.00	L/N80	244,48	220,45	269,88	5,5	127,00	912	1520	55
9-5/8	43.50	L/N80	244,48	218,41	269,88	5,5	127,00	1040	1733	55
9-5/8	47.00	L/N80	244,48	216,54	269,88	5,5	127,00	1116	1859	55
9-5/8	53.50	L/N80	244,48	215,90 <sup>d</sup>	269,88	5,5	127,00	1251	2087	55
9-5/8	40.00	C90	244,48	220,45	269,88	5	127,00	915	—	55
9-5/8	43.50	C90	244,48	218,41	269,88	5	127,00	999	—	55
9-5/8	47.00	C90	244,48	216,54	269,88	5	127,00	1071	—	55
9-5/8	53.50	C90	244,48	215,90 <sup>d</sup>	269,88	5	127,00	1340	—	55
9-5/8	40.00	C/T95	244,48	220,45	269,88	5,5	127,00	1033	—	55
9-5/8	43.50	C/T95	244,48	218,41	269,88	5,5	127,00	1129	—	55
9-5/8	47.00	C/T95	244,48	216,54	269,88	5,5	127,00	1211	—	55
9-5/8	53.50	C/T95	244,48	215,90 <sup>d</sup>	269,88	5,5	127,00	1318	—	55
9-5/8	43.50	P110	244,48	218,41	269,88	6	127,00	1239	—	55
9-5/8	47.00	P110	244,48	216,54	269,88	6	127,00	1326	—	55
9-5/8	53.50	P110	244,48	215,90 <sup>d</sup>	269,88	6	127,00	1481	—	55

<sup>a</sup> L/N80 implies L80 Type 1, N80 Type1 and N80Q.

<sup>b</sup> End of pipe to apex of triangle

<sup>c</sup> The recommended mass of thread compound shown in this table is for a compound containing metals, including lead (i.e. former API Bull 5A2) which has a specific gravity of approximately 2. Use of compounds such as described in ISO 13678 requires less mass to achieve an equivalent volume of thread compound. Use of excessive thread compound may be detrimental to leak resistance.

NOTE For the purposes of this provision, API RP 5A3 is equivalent to ISO 13678.

<sup>d</sup> The alternative size drift (see Table C.32) is shown.

**Table C.81 — Marking instructions for API licensees (see Annex F)**

1	2	Mark or symbol <sup>b</sup>	Stencil and/or stamp marking requirements <sup>a</sup>				
			Groups 1 and 3		Groups 2 and 4		All groups
			Pipe and pup joints	Couplings and accessories	Pipe and pup joints	Couplings and accessories	Coupling stock
3	4	5	6	7	8		
1	Licensed manufacturer's name or mark (optional; neither is required)	«.....»	D or P	D or P	P	P	P
2	ISO 11960 and/or API 5CT at manufacturer's option or as specified on purchase agreement.	ISO 11960 <sup>c</sup> 5CT <sup>d</sup>	D or P D or P	D or P D or P	P P	P P	P P
	API license number	«.....»	D or P	D or P	P	P	P
	API monogram	«.....»	D or P	D or P	P	P	P
	Date of manufacture as in F.1.8 or F.1.9	«.....»	D or P	D or P	P	P	P
3	Unthreaded pipe or special end finish, if applicable (place symbol after specification marking): — Unthreaded pipe either upset or non-upset — Pipe with special end-finish threaded by the pipe mill or processor — Completed couplings or completed accessories threaded with special end-finish — Coupling stock identification	UF SF SF CS	D or P D or P	D or P	P P	P	P
4	Size designation (fill in Label 1 designation from column 1 of Tables C.1, C.2 or C.3) Specified diameter for coupling stock	«.....»	P		P		P
5	Mass designation (fill in Label 2 designation from column 2 of Tables C.1, C.2 or C.3) Specified wall thickness for coupling stock	«.....»	D or P		P		P
6	Grade of pipe: — H40 — J55 — K55 — M65 — L80 Type 1 — L80 Type9Cr — L80 Type13Cr — N80 Type 1 — N80Q — C90 Type1 — C90 Type2 — C95 — T95 Type1 — T95 Type2 — P110 — Q125 Type1 — Q125 Type2 — Q125 Type3 — Q125 Type4 All grade designations	H J K M L L9 L13 N1 NQ C90-1 C90-2 C T95-1 T95-2 P Q1 Q2 Q3 Q4	D or P	D or P	P	P	P
7	Reduced alternative impact test temperature, if applicable. Fill in specified test temperature for full-size specimens, including ± symbol and °C:	«.....»C	P	P	P	P	
8	Heat treatment, if applicable: — J55, K55 or M65 normalized — J55, K55 or M65 quenched & tempered	Z Q	P P	P P	P P	P P	P P

Table C.81 (continued)

Marking sequence		Mark or symbol <sup>b</sup>	Stencil and/or stamp marking requirements <sup>a</sup>				
			Groups 1 and 3		Groups 2 and 4		All groups
			Pipe and pup joints	Couplings and accessories	Pipe and pup joints	Couplings and accessories	Coupling stock
1	2	3	4	5	6	7	8
9	Process of manufacture: — Seamless — Electric-welded All designations	S E	D or P		P		
10	Supplementary requirements, if applicable: — A.2 (SR1) — A.3 (SR2) — A.4 (SR9) (fill in type) — A.8 (SR13) — A.10 (SR16) (fill in minimum full-size energy absorption requirement in joules and test temperature including ± symbol and °C) — A.11 (SR22) — Annex H (PSL)	S1 S2 S9Q«.....» S13 S16«.....»C S22 L2 or L3	P P  P P P	D or P	P P  P P	P P	P
11	Hydrostatic test pressure <sup>e</sup> (fill in the actual test pressure in MPa) All designations	P«.....»	P		P		
12	Type of thread, if applicable: — For manufacturers, processors or threaders of casing buttress, extreme-line or round threads (fill in type of thread from Table C.67). — For threaders of tubing threads (fill in type of thread from Table C.67)	«.....» «.....»	P P		P P		
13	Full length drift test, if applicable: — Standard (casing or tubing) — Alternative (casing or tubing) where «.....» is the size of the alternative drift. — For casing specified for tubing service and drift-tested in accordance with 8.10 All designations	D DA«.....» DT42	P		P		
14	Serialization of Grades C90, T95 and Q125				D <sup>f</sup> or P	D <sup>f</sup> or P	P
15	Tin plating of couplings, if applicable	T		P		P	
16	Couplings H40, J55 and K55 only visually inspected	V		P			
NOTE See F.4 for mandatory colour code requirements.							
<p><sup>a</sup> D = optional (die) stamping; P = Requirement for (paint) stencilling. Optional marking is permitted as specified in F.1 and F.2.</p> <p><sup>b</sup> A blank space, «.....», indicates information to be filled in.</p> <p><sup>c</sup> The manufacturer may include "API" before "5CT".</p> <p><sup>d</sup> Alternative markings for the standards are: "5CT", "API 5CT", "ISO 11960 5CT".</p> <p><sup>e</sup> Pipe can be identified as manufactured to SI units by the marked hydro-test pressure which will be less than 100 (MPa), while the pressure marked for pipe manufactured to USC units (psi) will be over 1 000. This information is used to clearly identify the units used for CVN markings, which shall be in the same unit system as the pressure markings.</p> <p><sup>f</sup> Stamp marking shall conform to the requirements of F.2.5.</p>							

**Annex D**  
(normative)

**Figures in SI (USC) units**

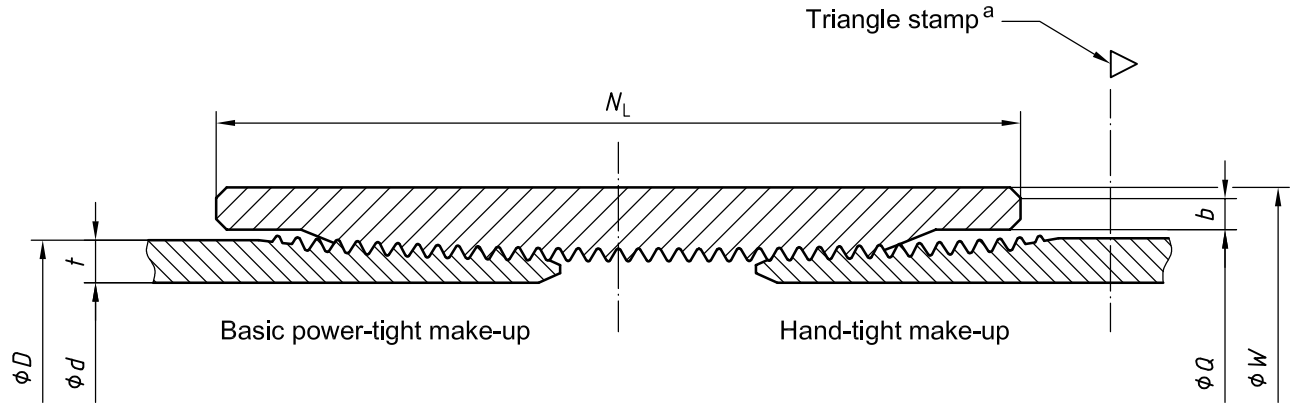

<sup>a</sup> A 9,52 mm (3/8 in) high equilateral triangle die stamp shall be placed at a distance of  $L_4 + 1,59$  mm (+ 1/16 in) from each end of Label 1: 16, 18-5/8 and 20 short round-thread casing in Grades H40, J55, K55 and M65. See Table C.24 or Table E.24 for pipe dimensions, Table C.35 or Table E.35 for coupling dimensions and API Spec 5B for  $L_4$ .

**Figure D.1 — Short round-thread casing and coupling**

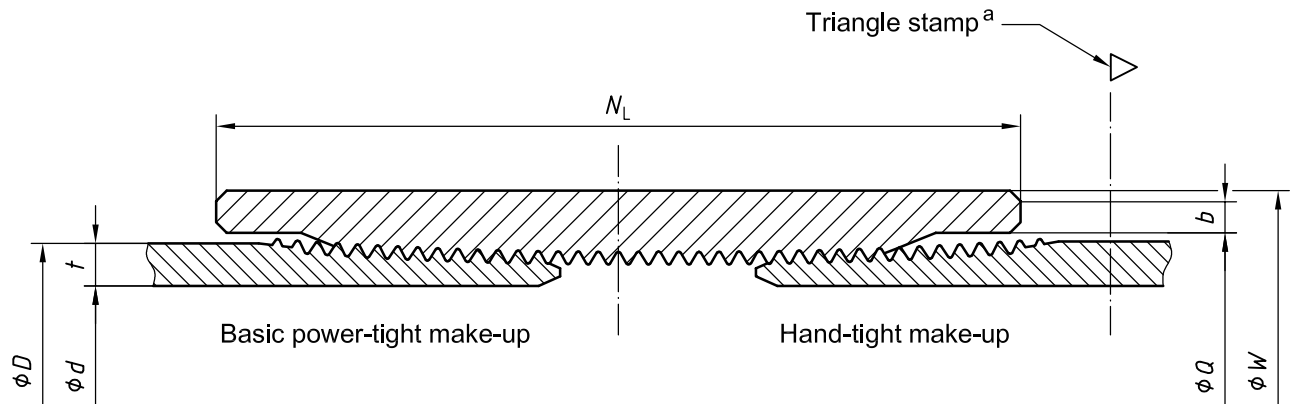

<sup>a</sup> A 9,52 mm (3/8 in) high equilateral triangle die stamp shall be placed at a distance of  $L_4 + 1,59$  mm (1/16 in) from each end of Label 1: 20 long round-thread casing in Grades H40, J55, K55 and M65. See Table C.24 or Table E.24 for pipe dimensions, Table C.35 or Table E.35 for coupling dimensions and API Spec 5B for  $L_4$ .

**Figure D.2 — Long round-thread casing and coupling**

Dimensions in millimetres (inches)

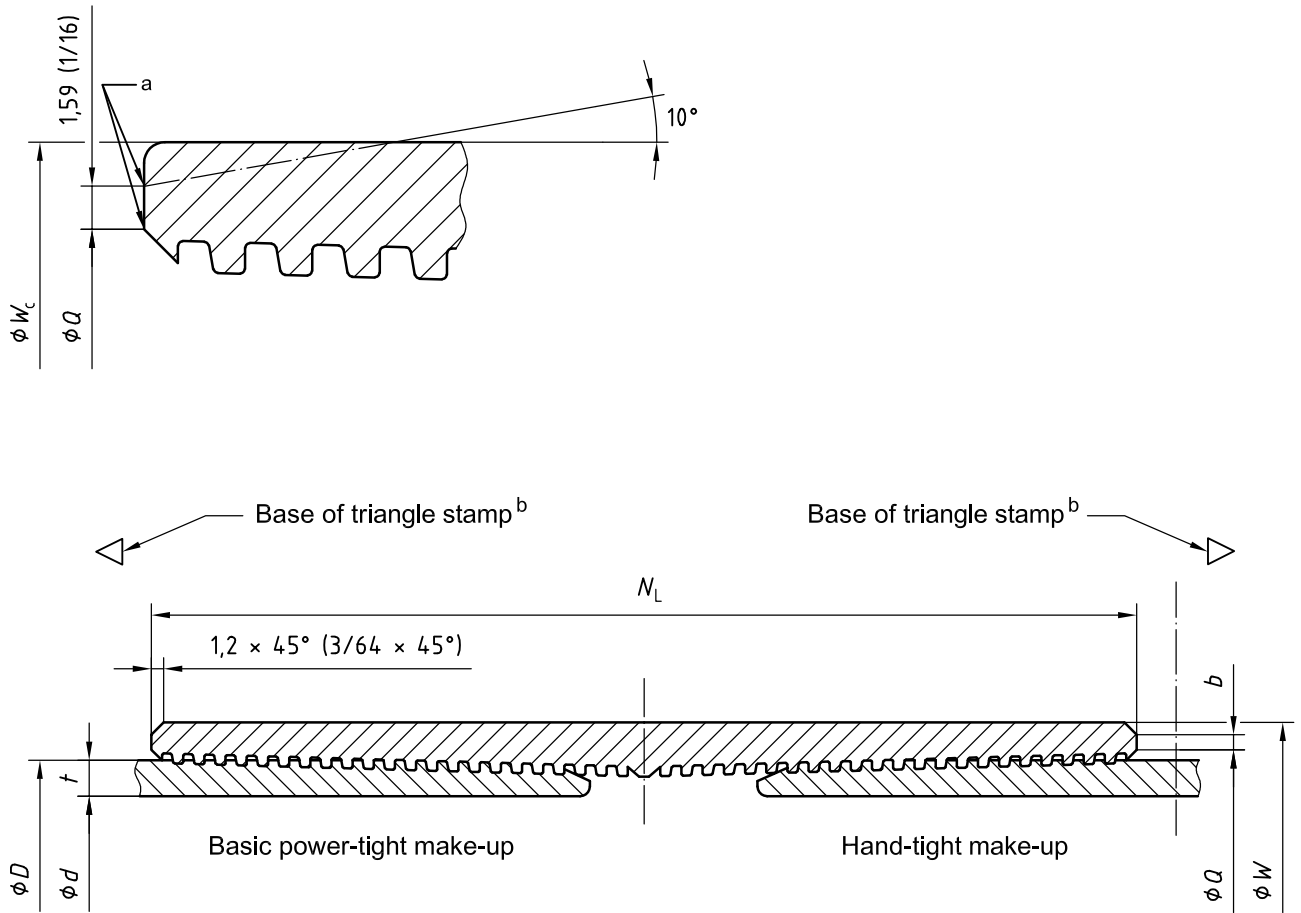

<sup>a</sup> On special-clearance couplings, the inside and outside edges of the bearing face shall be broken or rounded. A 10° bevel (both ends) shall be furnished only when specified on the purchase order.

<sup>b</sup> A 9,52 mm (3/8 in) high equilateral triangle die-stamp or paint band shall be placed at a distance of A1 from each end of buttress casing. See Table C.24 or Table E.24 for pipe dimensions, Table C.36 or Table E.36 for coupling dimensions and API Spec 5B for A1.

**Figure D.3 — Buttress-thread casing and coupling**

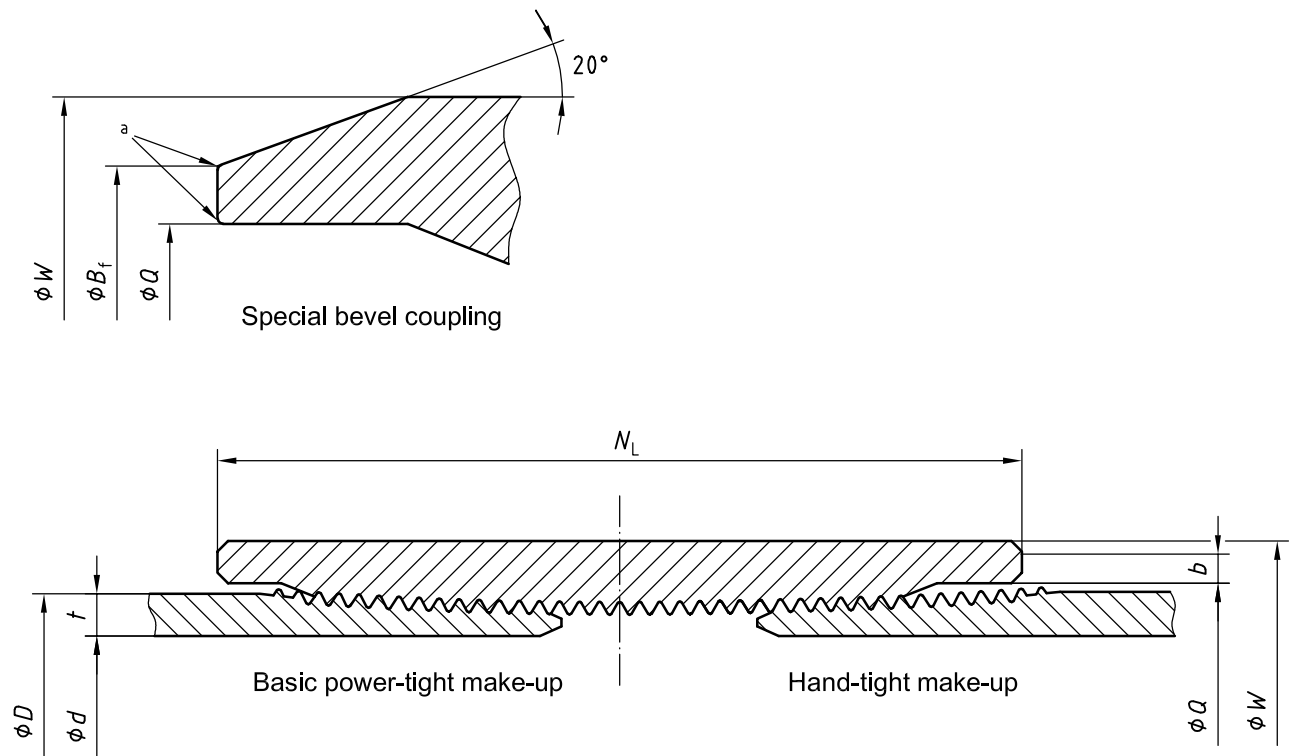

NOTE See Table C.25 or Table E.25 for pipe dimensions, Table C.37 or Table E.37 for coupling dimensions and API Spec 5B for thread details.

<sup>a</sup> On special bevel couplings, the inside and outside edges of the bearing face shall be broken or rounded.

**Figure D.4 — Non-upset tubing and coupling**

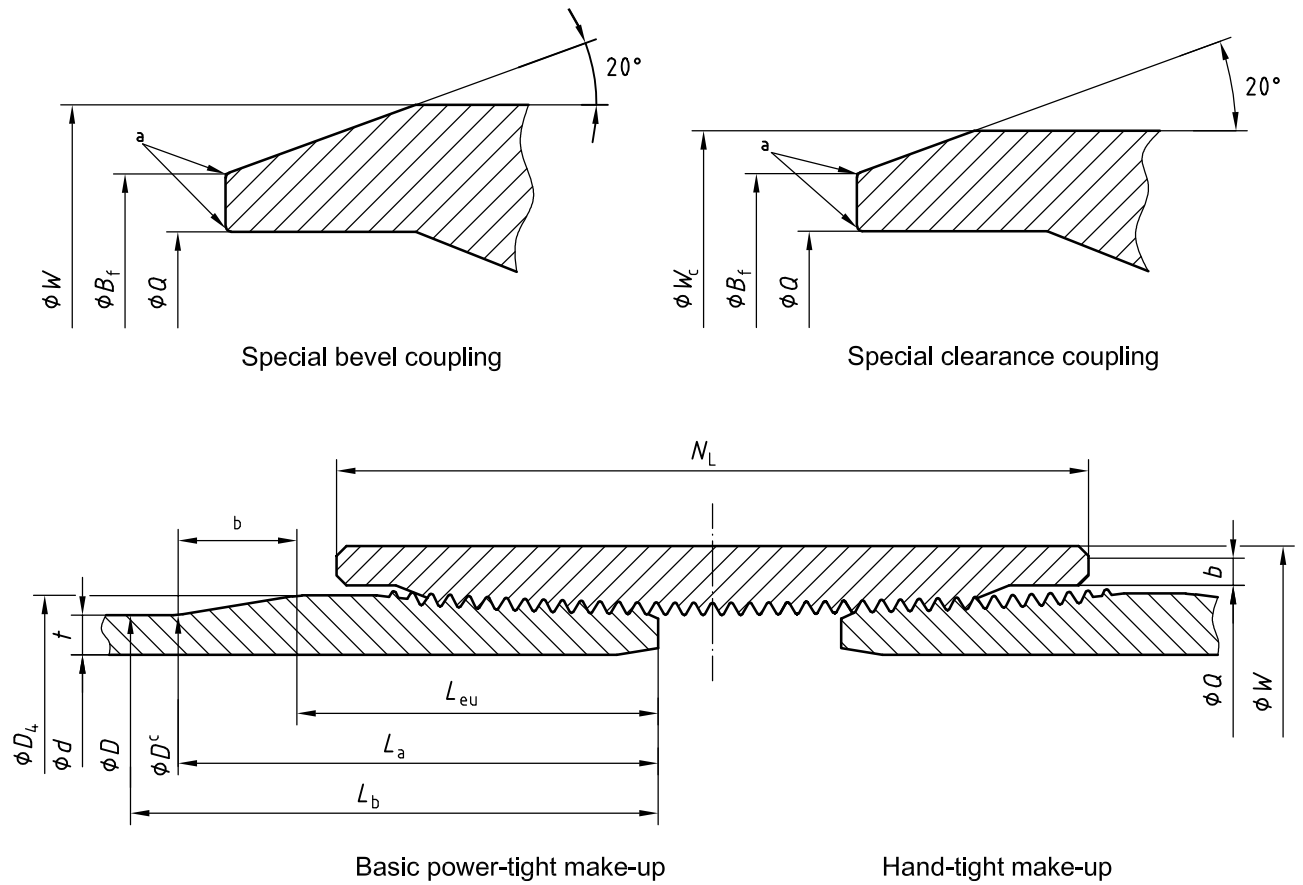

NOTE See Tables C.25 and C.27 or Tables E.25 and E.27 for pipe dimensions, Table C.38 or Table E.38 for coupling dimensions and API Spec 5B for thread details.

- a On special bevel couplings and special clearance couplings, the inside and outside edges of the bearing face shall be broken or rounded.
- b Upset run-out interval, not to be confused with  $b$  on the right-hand side of the figure which indicates the coupling bearing face dimension.
- c See 8.11.1 for tolerance on outside diameter at a distance  $L_a$  from end of pipe.

**Figure D.5 — External-upset tubing and coupling**

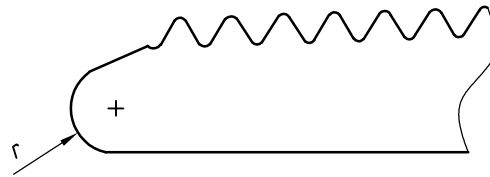

Label 1	Radius <sup>a</sup> <i>r</i> mm (in)
1	2
2-3/8	2,4 (3/32)
2-7/8	2,4 (3/32)
3-1/2	3,2 (1/8)
4-1/2	3,2 (1/8)

<sup>a</sup> These dimensions are for reference only and are not subject to measurement for determining product acceptance.

NOTE See API Spec 5B for product acceptance.

Figure D.6 — Rounded nose for external-upset tubing

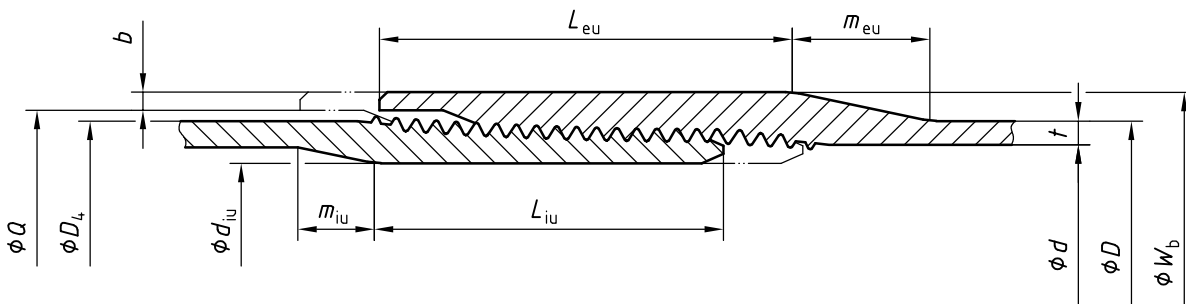

NOTE 1 Dashed lines indicate power-tight make-up.

NOTE 2 See Tables C.25 and C.28 or Tables E.25 and E.28 for pipe dimensions and API Spec 5B for thread details.

Figure D.7 — Integral-joint tubing



Dimensions in millimetres (inches)

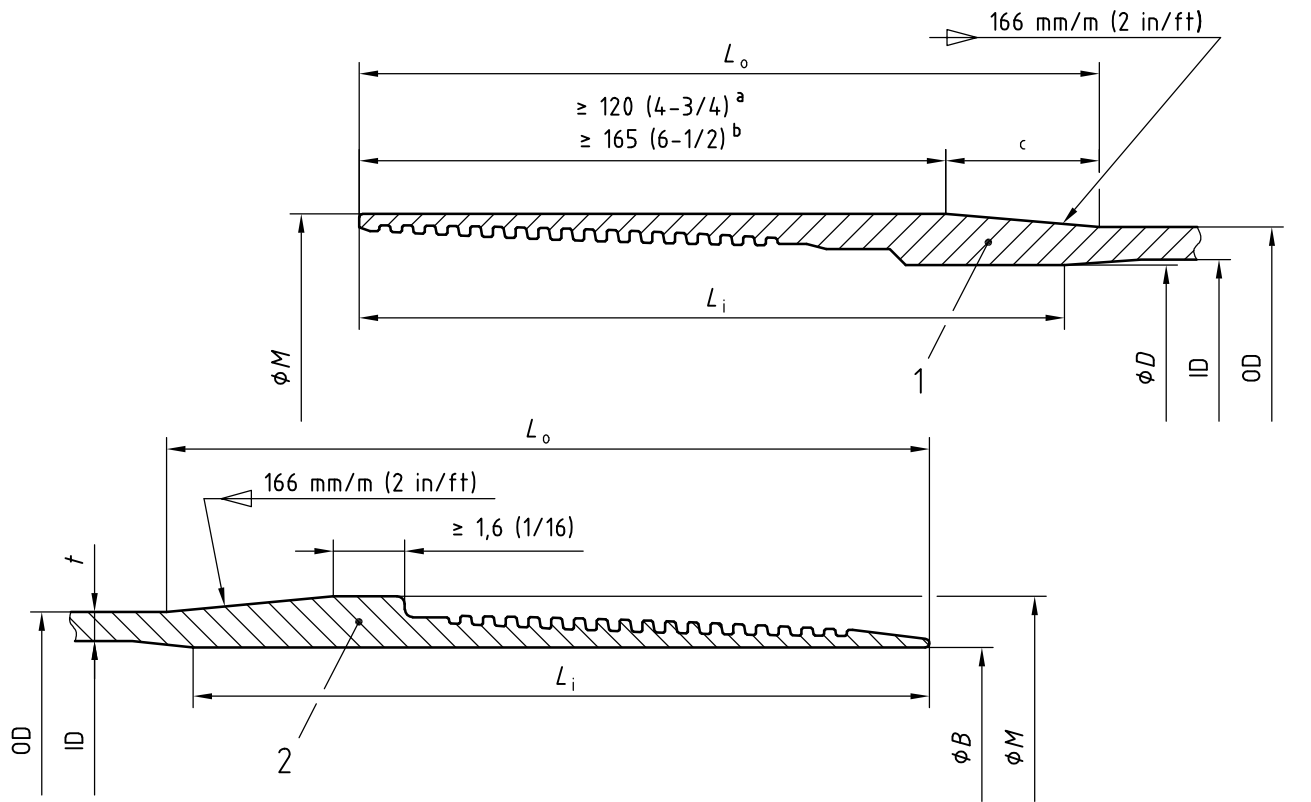

a) Box and pin members

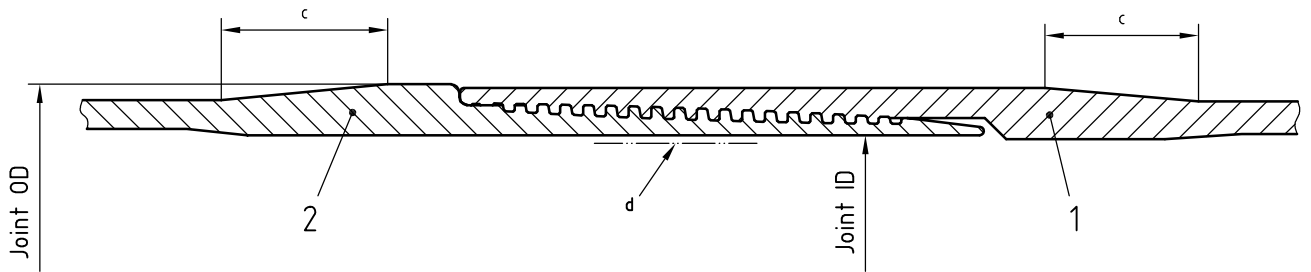

b) Power-tight make-up

**Key**

- 1 box
- 2 pin

- a For 193,70 (7-5/8) outside diameter and smaller.
- b For 219,10 (8-5/8) outside diameter and larger.
- c Upset run-out interval, including both internal and external upset tapers.
- d Drift diameter.

**Figure D.8 — Extreme-line casing**

Label 1	Length of upset mm (in)					
	Pin <sup>a</sup> min. $L_i$		Box <sup>a</sup> min. $L_i$		Pin or box <sup>b</sup> max. $L_o$	
5	168	(6-5/8)	177	(7)	204	(8)
5-1/2	168	(6-5/8)	177	(7)	204	(8)
6-5/8	168	(6-5/8)	177	(7)	204	(8)
7 <sup>c</sup>	168	(6-5/8)	177	(7)	204	(8)
7-5/8	168	(6-5/8)	177	(7)	204	(8)
8-5/8	203	(8)	222	(8-3/4)	280	(11)
9-5/8	203	(8)	222	(8-3/4)	280	(11)
10-3/4	203	(8)	222	(8-3/4)	324	(12-3/4)

<sup>a</sup>  $L_i$  is the minimum length from end of pipe of the machined diameter,  $B$ , on pin, or machined diameter,  $D$ , plus length of thread on box, to the beginning of the internal upset run-out.

<sup>b</sup> For pup joints only,  $L_o$  may be 127 mm (5 in) longer than specified for either pin or box.

<sup>c</sup>  $L_o$  shall be 228,6 mm (9 in) maximum for Label 1:7, Label 2: 35 and Label 1:7, Label 2:38 designation casing.

NOTE See Table C.26 or Table E.26 for pipe dimensions and API Spec 5B for thread details.

Figure D.8 — Extreme-line casing (continued)

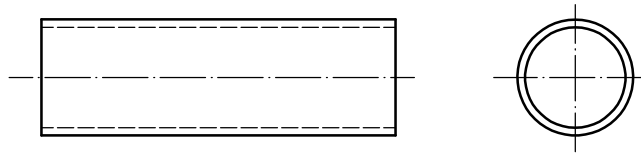

a) Full-section specimen

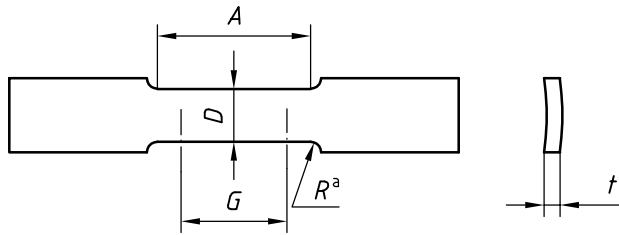

b) Strip specimen<sup>a</sup>

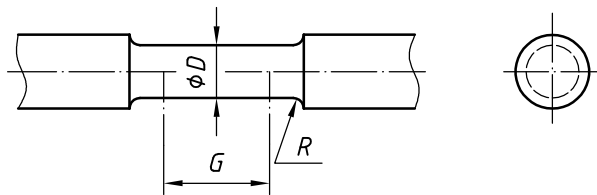

c) Round bar specimen

<sup>a</sup> See 10.4.5 for testing without use of suitable curved-face testing grips.

Dimension	Strip specimen mm (in)	Round bar specimen mm (in)	
		$D = 12,7 (0.500)$	$D = 8,9 (0.350)$
Gauge length, $G$	$50,8 \pm 0,13$ ( $2.000 \pm 0.005$ )	$50,8 \pm 0,13$ ( $2.000 \pm 0.005$ )	$35,6 \pm 0,13$ ( $1.400 \pm 0.005$ )
Diameter or width, $D$	38,1 (1.500) approx.	$12,7 \pm 0,25$ ( $0.500 \pm 0.010$ )	$8,9 \pm 0,18$ ( $0.350 \pm 0.007$ )
Radius of fillet, min., $R$	25,4 (1.000)	9,5 (0.375)	6,4 (0.250)
Length of reduced section, min., $A$	57,2 (2.250)	57,2 (2.250)	44,5 (1.750)

Figure D.9 — Tensile test specimens

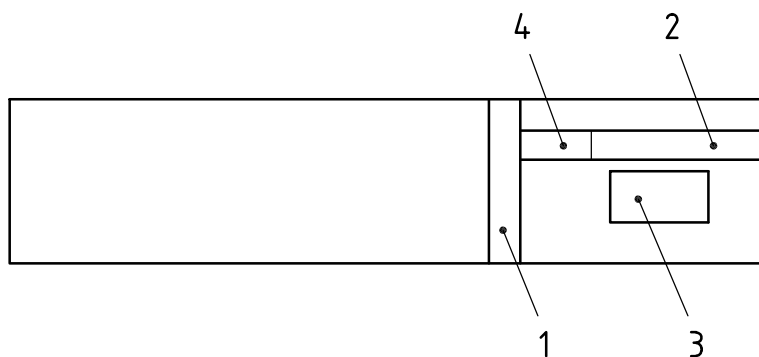

**Key**

- 1 hardness test ring [see Figure D.11 for detail, 6,4 mm (0.25 in) minimum thickness]
- 2 tensile test specimen
- 3 impact test samples (See Figure D.12 for detail)
- 4 hardness test sample [6,4 mm (0.25 in) minimum thickness], to be removed from tensile test sample prior to tensile test piece preparation

NOTE The hardness test ring shall be removed at mid-length position of individually heat-treated coupling blanks.

**Figure D.10 — Typical location of test samples removed from casing, tubing, coupling, pup-joint and accessory material**

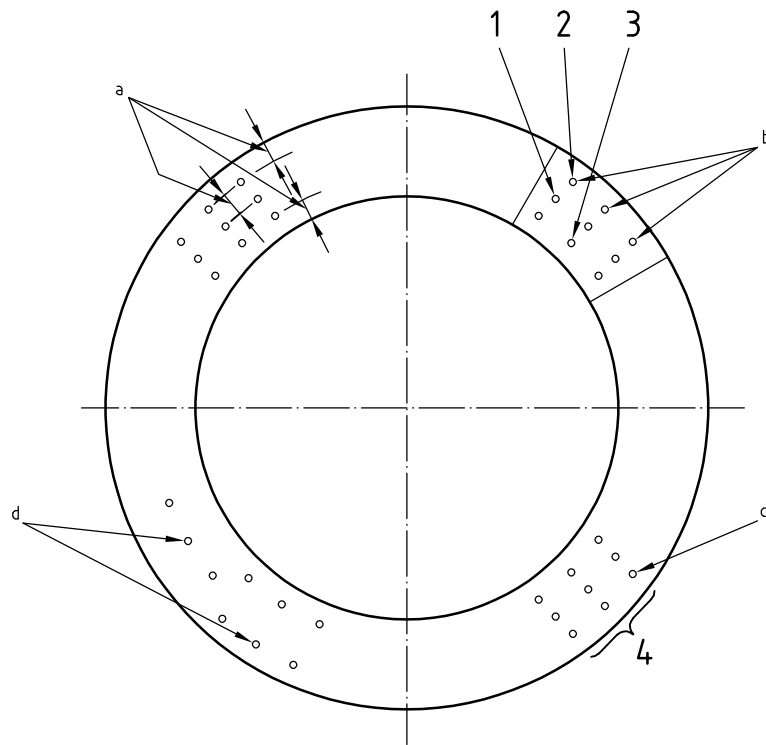

**Key**

- 1 indentation at mid-wall location
- 2 indentation at OD location
- 3 indentation at ID location
- 4 hardness indentation test block

- a The outer and inner tests shall be taken between 2,54 mm (0.10 in) and 3,81 mm (0.15 in) from the applicable surface. An error may result if an indentation is spaced closer than  $2\frac{1}{2}$  diameters from its centre to the edge of the specimen or 3 diameters from another indentation measured centre-to-centre.
- b The mean hardness number is the average of three Rockwell hardness numbers in the same location.
- c Rockwell hardness indentation data are called Rockwell hardness numbers.
- d Alternate spacing of rows permitted for thin-wall pipe.

**Figure D.11 — Through-wall hardness test**

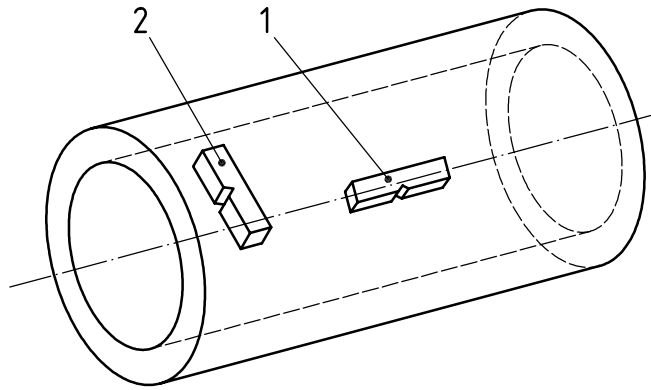

All impact test specimens shall be 10 mm × 10 mm if possible.

The notch shall be oriented perpendicular to the axis of the tube (normal to the tube surface).

**Key**

- 1 longitudinal specimen
- 2 transverse specimen

**Figure D.12 — Impact test specimen orientation**

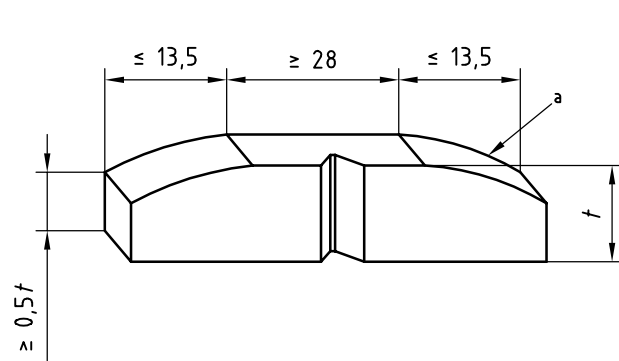

Dimensions in millimetres

- <sup>a</sup> Outside diameter curvature.

**Figure D.13 — Charpy specimen dimensions**

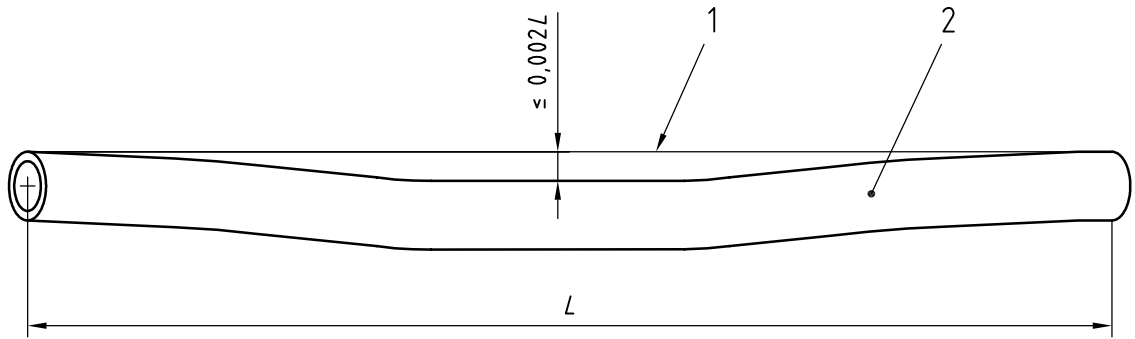

**Key**

- 1 taut string or wire
- 2 pipe

**Figure D.14 — Measuring full-length straightness**

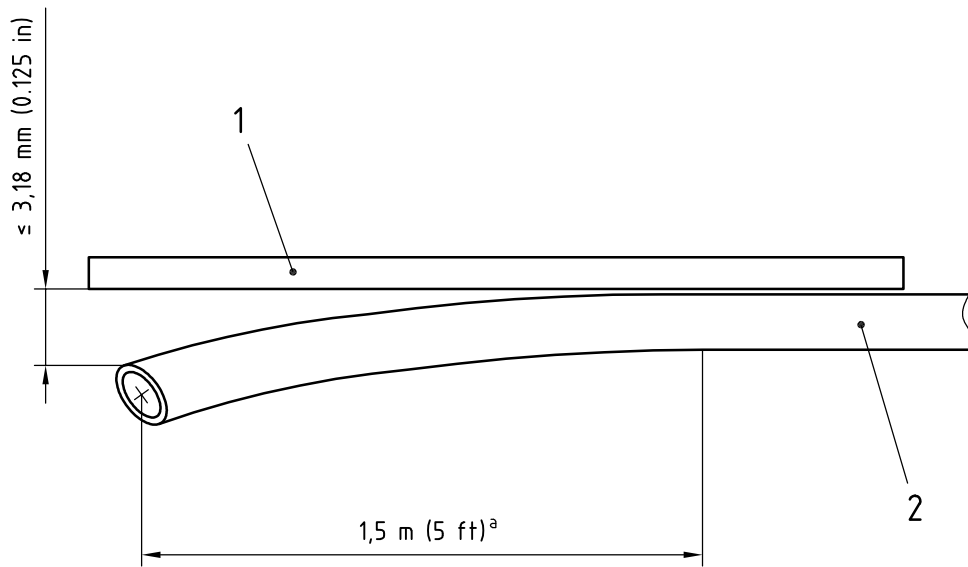

**Key**

- 1 straightedge, length 1,5 m (5 ft) minimum
- 2 pipe
- <sup>a</sup> Hooked end.

**Figure D.15 — Measuring end straightness**

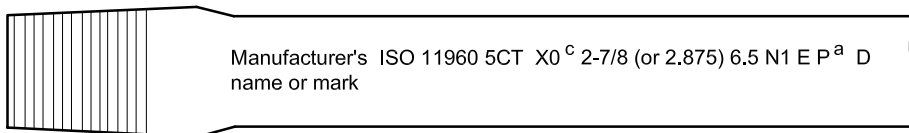

**Stencil marking** [beginning at least 0,6 m (2 ft) from either externally threaded end]

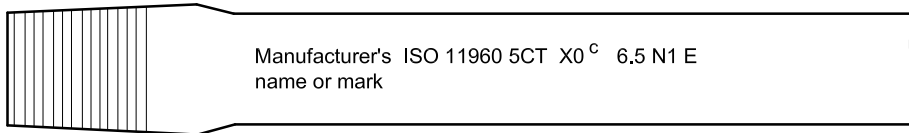

**Stamp marking — Optional** [within approximately 0,3 m (1 ft) of either externally threaded end]

**a) EXAMPLE 1 — Tubing** Label 1: 2-7/8, Label 2: 6.5, Grade N80 Type 1, electric weld, external upset, threaded (by the manufacturer) pin-by-pin without couplings

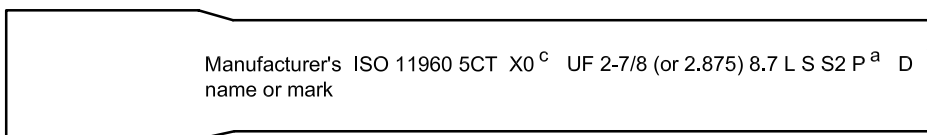

**Stencil marking** [beginning at least 0,6 m (2 ft) from either end]

**b) EXAMPLE 2 — Tubing** Label 1: 2-7/8, Label 2: 8.7, Grade L80 Type 1, seamless, external upset, plain end. Additional requirements include hydrostatic testing to 94,5 MPa (13 700 psi) and inspection to SR2

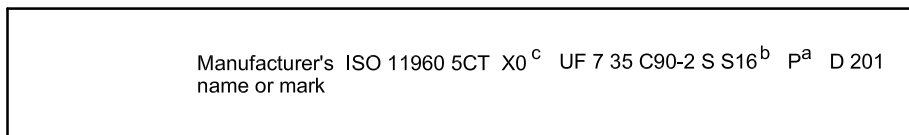

**Stencil marking** [beginning at least 0,6 m (2 ft) from either end]

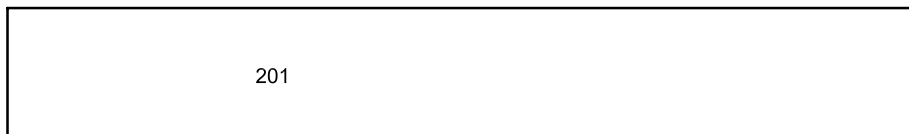

**Stamp marking — Optional** [within approximately 0,3 m (1 ft) from either end]

**c) EXAMPLE 3 — Casing** Label 1: 7, Label 2: 35, Grade C90 Type 2, seamless, plain end, serial number 201. Supplementary requirement 16 (SR16) for test at -10 °C (+14 °F). The pipe was pressure-tested to 69 MPa (10 000 psi)

**Figure D.16 — Examples of marking requirements and sequence for manufacturers and threaders using Clause 11 and Table C.68 or E.68**



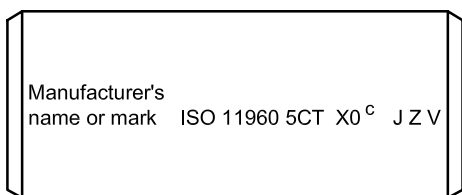

**Stencil marking**

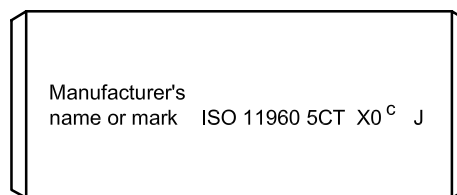

**Stamp marking — Optional**

NOTE Marking in the centre of the coupling may be stamped in either the longitudinal or transverse direction.

**d) EXAMPLE 4 — Tubing coupling** for Label 1; 2-7/8, Grade J55, normalized upset (or non-upset) tubing, only visual inspection required

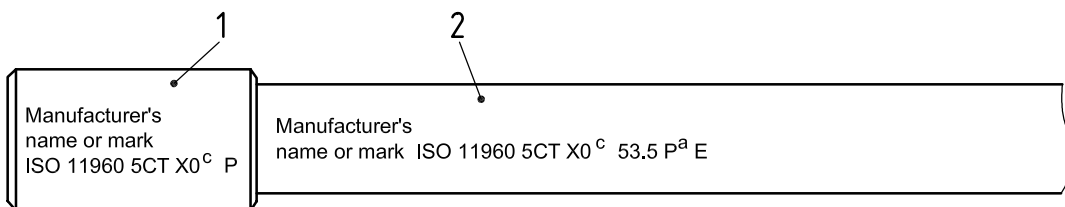

**Stencil marking** [beginning not less than 0,6 m (2 ft) from the coupling]

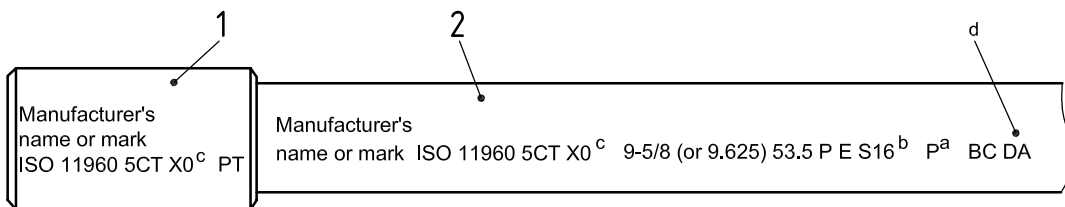

**Stamp marking — Optional** [within approximately 0,3 m (1 ft) from the coupling]

NOTE Marking in the centre of the coupling may be in either the longitudinal or transverse direction.

**e) EXAMPLE 5 — Buttress casing with coupling:** Label 1: 9-5/8, Label 2: 53.5, Grade P110, electric weld; supplementary requirements are SR11 and SR16 for test at  $-18\text{ }^{\circ}\text{C}$  ( $0\text{ }^{\circ}\text{F}$ ) and 215,9 mm (8.500 in) drift test. Coupling is tin-plated

**Figure D.16 — Examples of marking requirements and sequence for manufacturers and threaders using Clause 11 and Table C.68 or E.68 (continued)**

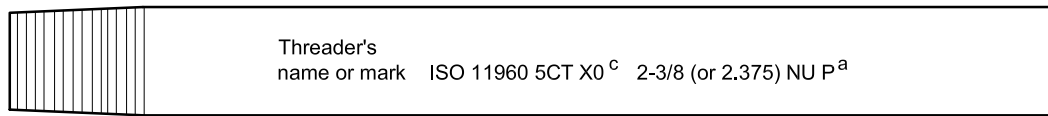

**Stencil marking (adjacent to the threads)**

Threader stencil marking shall be placed adjacent to the threads and is in addition to marking applied by other pipe manufacturers.

**f) EXAMPLE 6 — Threader:** Label 1: 2-3/8, Label 2: 4, Grade J55 non-upset thread, and hydrostatically tested to alternative test pressure of 43,5 MPa (6 300 psi)

**Key**

- 1 coupling
- 2 pipe

<sup>a</sup> Express pressure in megapascals for pipe manufactured to SI units and in pounds per square inch for pipe manufactured to USC units.

<sup>b</sup> Express the CVN requirements in joules and the temperature in degrees Celsius for pipe manufactured to SI units, and in foot-pounds and degrees Fahrenheit for pipe manufactured to USC units.

<sup>c</sup> Date of manufacture: This example is for product manufactured in accordance with the current edition of ISO 11960 during the period of overlap with application (see Foreword and 11.1.9) of the previous edition. Note that “X” is used for the last digit of the year of manufacture so that it is a generic example and will not change with subsequent editions of this International Standard. For examples of other dates of manufacture, see Figure D.23.

<sup>d</sup> Express alternative drift diameter in millimetres for pipe manufactured to SI units and in inches for pipe manufactured to USC units.

**Figure D.16 — Examples of marking requirements and sequence for manufacturers and threaders using Clause 11 and Table C.68 or E.68 (continued)**

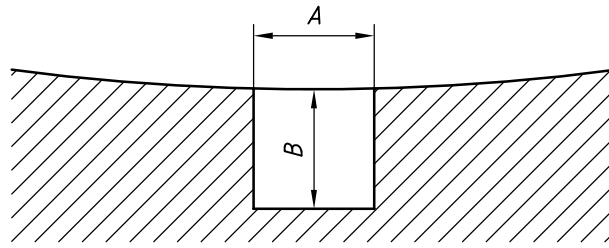

a) L2 Notch — Inner surface

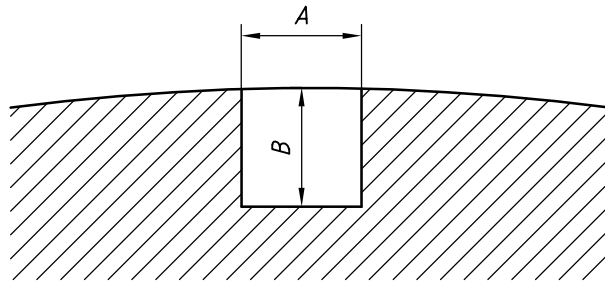

b) L2 Notch — Outer surface

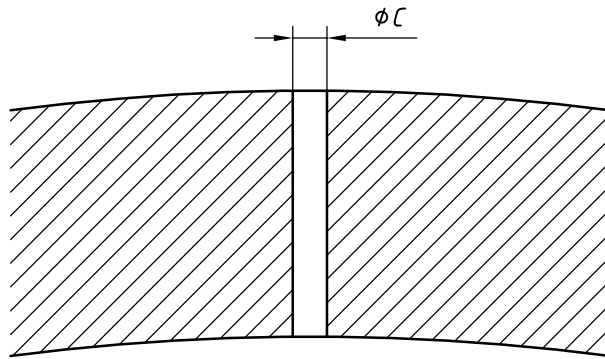

c) Drilled hole

**Key**

- A notch width
- B notch depth
- C hole diameter

Notch length for a) and b):

- for eddy current, 38,10 mm (1.5 in) maximum total length;
- for ultrasonic, 50,80 mm (2 in) maximum at full depth;
- for diverted flux, the length of notch shall be as required by the equipment design to provide a reproducible signal when the reference standard is passed through the equipment at the inspection-line speed for the pipe being inspected. Three passes through the equipment shall be carried out to ensure reproducibility.

**Figure D.17 — SR11.1 Reference standard**

Dimensions in millimetres (inches)

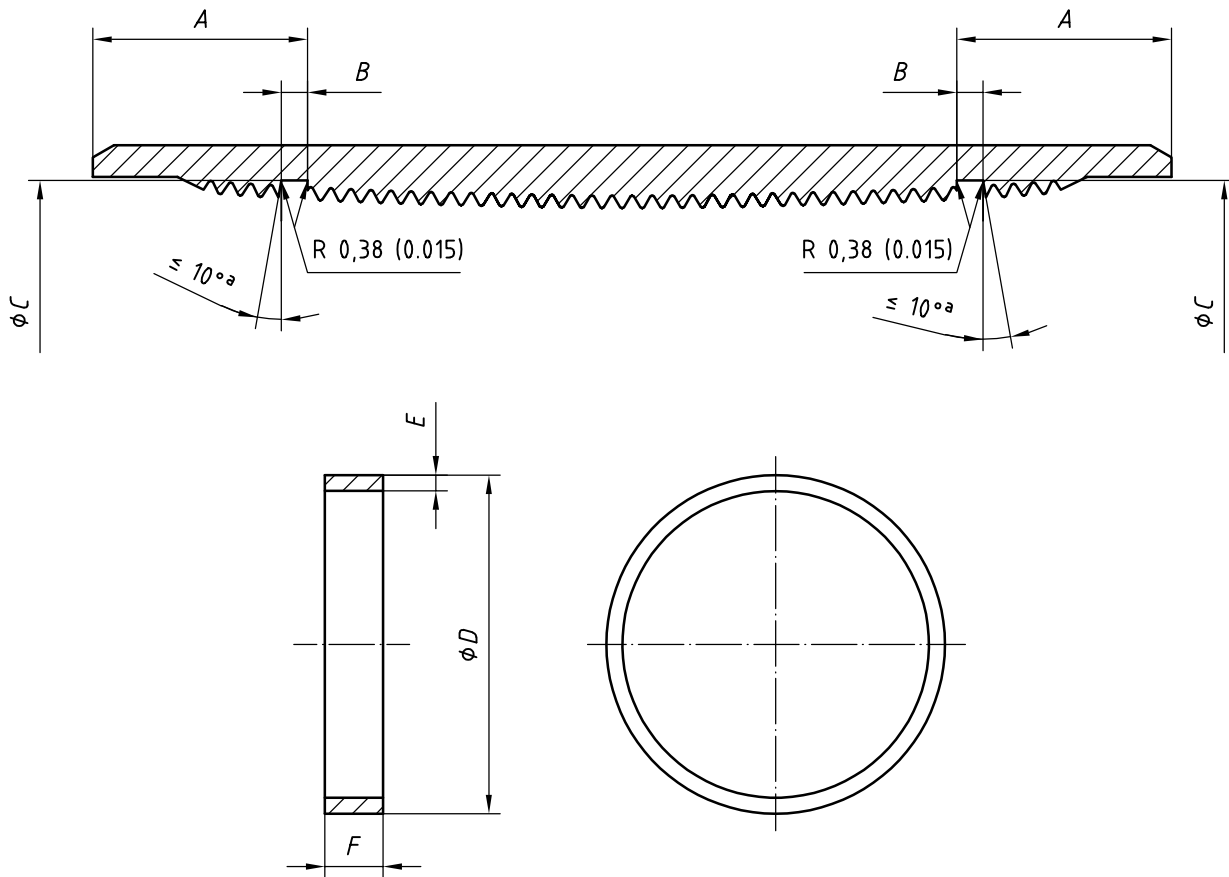

<sup>a</sup> Angle optional. Seal ring groove and thread pitch diameter shall be concentric within 0,51 mm (0.020 in) of indicated thread run-out.

**Figure D.18 — SR13.1 Seal-ring coupling and non-metallic ring for round-thread casing**

8 Round casing Label 1	Outside diameter	Coupling dimensions mm (in)			Ring dimensions mm (in)		
		A ± 3,2 (± 0.125)	B ± 0,13 (± 0.005)	C ± 0,25 (± 0.010)	D ± 0,38 (± 0.015)	E +0,25 0 (+0.010) 0	F +0,38 0 (+0.015) 0
1	2	3	4	5	6	7	8
4-1/2	114,30	34,9 (1.375)	4,78 (0.188)	114,63 (4.513)	115,27 (4.538)	2,54 (0.100)	3,96 (0.156)
5	127,00	38,1 (1.500)	4,78 (0.188)	127,13 (5.005)	127,76 (5.030)	2,54 (0.100)	3,96 (0.156)
5-1/2	139,70	38,1 (1.500)	4,78 (0.188)	139,83 (5.505)	140,46 (5.530)	2,54 (0.100)	3,96 (0.156)
6-5/8	168,28	44,5 (1.750)	4,78 (0.188)	168,00 (6.614)	168,63 (6.639)	2,54 (0.100)	3,96 (0.156)
7	177,80	44,5 (1.750)	4,78 (0.188)	177,52 (6.989)	178,16 (7.014)	2,54 (0.100)	3,96 (0.156)
7-5/8	193,68	44,5 (1.750)	4,78 (0.188)	193,29 (7.610)	193,93 (7.635)	2,54 (0.100)	3,96 (0.156)
8-5/8	219,09	47,6 (1.875)	4,78 (0.188)	218,52 (8.603)	219,15 (8.628)	2,54 (0.100)	3,96 (0.156)
9-5/8	244,48	47,6 (1.875)	4,78 (0.188)	243,92 (9.603)	244,55 (9.628)	2,54 (0.100)	3,96 (0.156)
10-3/4	273,05	44,5 (1.750)	4,78 (0.188)	272,67 (10.735)	273,30 (10.760)	2,54 (0.100)	3,96 (0.156)
11-3/4	298,45	47,6 (1.875)	4,78 (0.188)	297,89 (11.728)	298,53 (11.753)	2,54 (0.100)	3,96 (0.156)
13-3/8	339,72	57,2 (2.250)	4,78 (0.188)	338,56 (13.329)	339,19 (13.354)	2,54 (0.100)	3,96 (0.156)
16	406,40	69,9 (2.750)	4,78 (0.188)	404,44 (15.923)	405,08 (15.948)	2,54 (0.100)	3,96 (0.156)
18-5/8	473,08	69,9 (2.750)	4,78 (0.188)	471,12 (18.548)	471,75 (18.573)	2,54 (0.100)	3,96 (0.156)
20	508,00	69,9 (2.750)	4,78 (0.188)	506,04 (19.923)	506,68 (19.948)	2,54 (0.100)	3,96 (0.156)

Figure D.18 — SR13.1 Seal-ring coupling and non-metallic ring for round-thread casing (continued)

Dimensions in millimetres (inches)

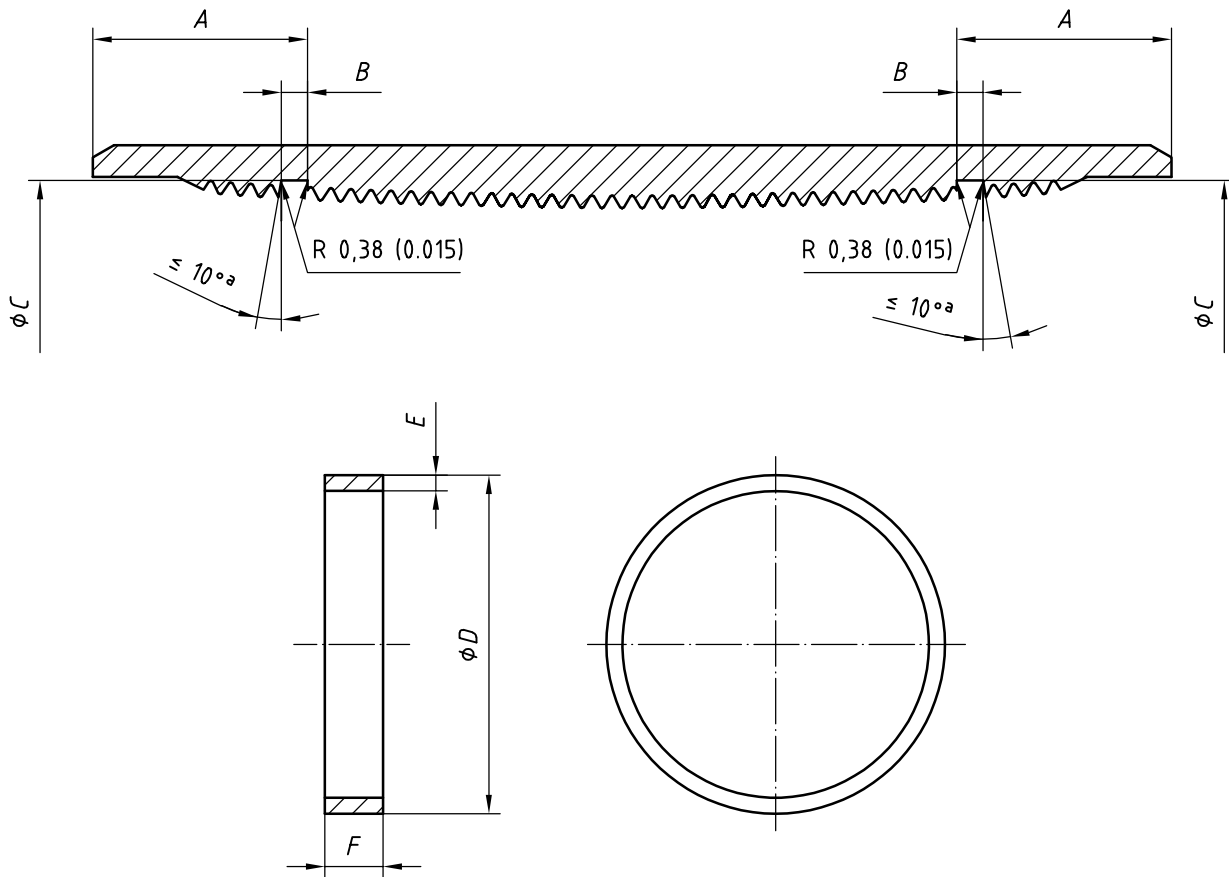

Seal ring groove and thread pitch diameter shall be concentric within 0,51 mm (0.020 in) of indicated thread run-out.

<sup>a</sup> Angle optional.

Buttress casing Label 1	Outside diameter	Coupling dimensions mm (in)			Ring dimensions mm (in)		
		A ± 3,2 (± 0.125)	B ± 0,13 (± 0.005)	C ± 0,25 (± 0.010)	D ± 0,38 (± 0.015)	E +0,25 0 (+0.010 0)	F +0,38 0 (+0.015 0)
1	2	3	4	5	6	7	8
4-1/2	114,30	76,2 (3.000)	4,78 (0.188)	115,21 (4.536)	115,85 (4.561)	2,54 (0.100)	3,96 (0.156)
5	127,00	81,0 (3.188)	4,78 (0.188)	127,46 (5.018)	128,09 (5.043)	2,54 (0.100)	3,96 (0.156)
5-1/2	139,70	81,0 (3.188)	4,78 (0.188)	140,16 (5.518)	140,79 (5.543)	2,54 (0.100)	3,96 (0.156)
6-5/8	168,28	81,0 (3.188)	4,78 (0.188)	168,73 (6.643)	169,37 (6.668)	2,54 (0.100)	3,96 (0.156)
7	177,80	82,6 (3.250)	4,78 (0.188)	178,16 (7.014)	178,79 (7.039)	2,54 (0.100)	3,96 (0.156)
7-5/8	193,68	85,7 (3.375)	4,78 (0.188)	193,85 (7.632)	194,49 (7.657)	2,54 (0.100)	3,96 (0.156)
8-5/8	219,09	85,7 (3.375)	4,78 (0.188)	219,25 (8.632)	219,89 (8.657)	2,54 (0.100)	3,96 (0.156)
9-5/8	244,48	85,7 (3.375)	4,78 (0.188)	244,65 (9.632)	245,29 (9.657)	2,54 (0.100)	3,96 (0.156)
10-3/4	273,05	85,7 (3.375)	4,78 (0.188)	273,23 (10.757)	273,86 (10.782)	2,54 (0.100)	3,96 (0.156)
11-3/4	298,45	88,9 (3.500)	4,78 (0.188)	298,42 (11.749)	299,06 (11.774)	2,54 (0.100)	3,96 (0.156)
13-3/8	339,72	95,3 (3.750)	4,78 (0.188)	339,29 (13.358)	339,93 (13.383)	2,54 (0.100)	3,96 (0.156)

Figure D.19 — SR13.2 Seal-ring coupling and non-metallic ring for buttress-thread casing

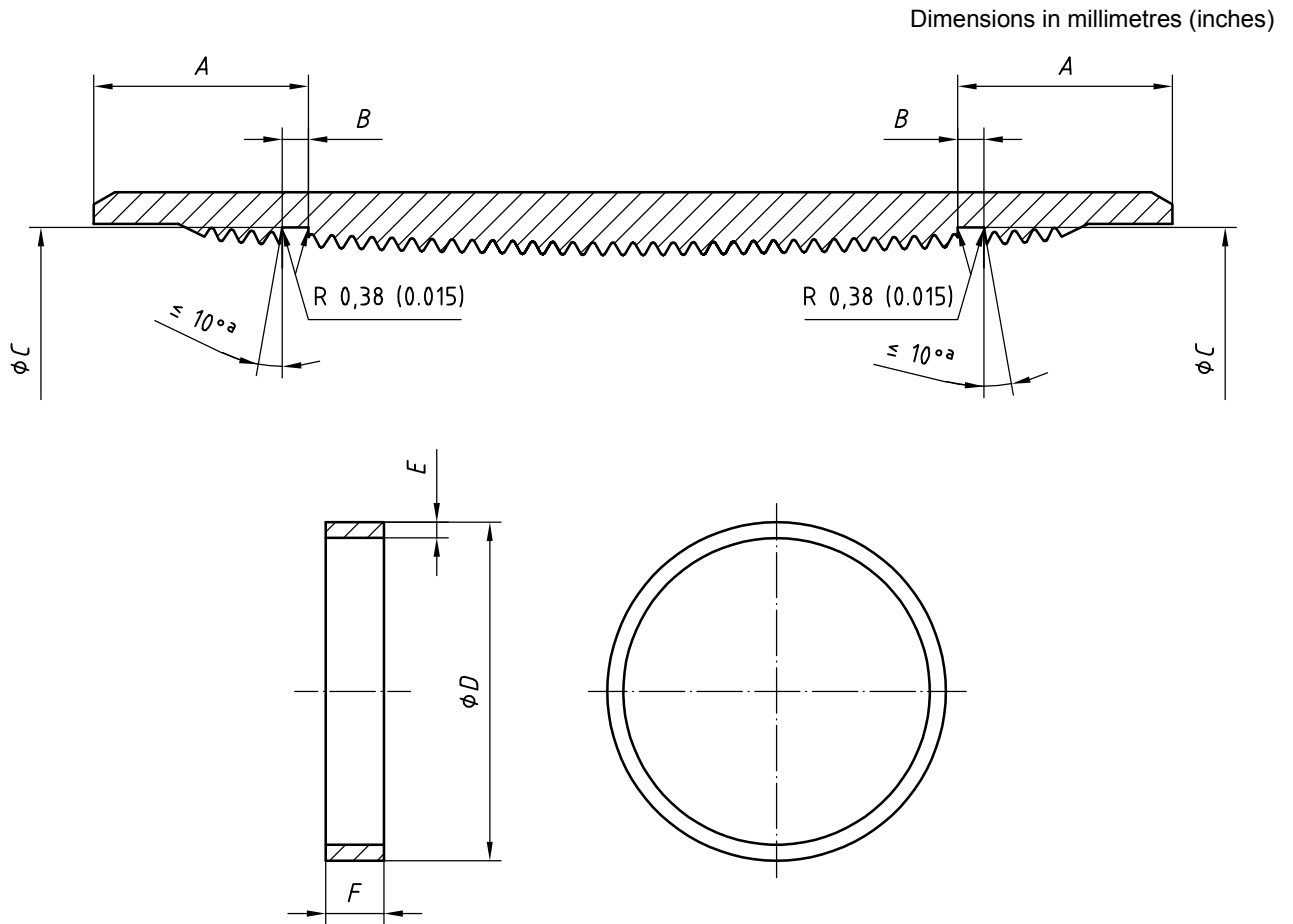

Seal ring groove and thread pitch diameter shall be concentric within 0,51 mm (0.020 in) of indicated thread runoff.

<sup>a</sup> Angle optional.

Non-upset tubing size Label 1	Outside diameter	Coupling dimensions mm (in)			Ring dimensions mm (in)		
		A ± 3,2 (± 0.125)	B ± 0,13 (± 0.005)	C ± 0,25 (± 0.010)	D ± 0,19 (± 0.075)	E +0,13 0 (+0.005 0)	F +0,38 0 (+0.015 0)
1	2	3	4	5	6	7	8
1.050	26,67	20,7 (0.813)	3,96 (0.156)	27,46 (1.081)	27,89 (1.098)	2,03 (0.080)	3,18 (0.125)
1.315	33,40	20,7 (0.813)	3,96 (0.156)	34,19 (1.346)	34,62 (1.363)	2,03 (0.080)	3,18 (0.125)
1.660	42,16	20,7 (0.813)	3,96 (0.156)	42,95 (1.691)	43,38 (1.708)	2,03 (0.080)	3,18 (0.125)
1.900	48,26	25,4 (1.000)	4,78 (0.188)	48,74 (1.919)	49,20 (1.937)	2,03 (0.080)	3,96 (0.156)
2-3/8	60,32	25,4 (1.000)	4,78 (0.188)	60,81 (2.394)	61,26 (2.412)	2,03 (0.080)	3,96 (0.156)
2-7/8	73,02	25,4 (1.000)	4,78 (0.188)	73,51 (2.894)	73,96 (2.912)	2,03 (0.080)	3,96 (0.156)
3-1/2	88,90	25,4 (1.000)	4,78 (0.188)	89,38 (3.519)	89,84 (3.537)	2,03 (0.080)	3,96 (0.156)
4	101,60	28,6 (1.125)	4,78 (0.188)	102,31 (4.028)	102,77 (4.046)	2,54 (0.100)	3,96 (0.156)
4-1/2	114,30	28,6 (1.125)	4,78 (0.188)	115,01 (4.528)	115,47 (4.546)	2,54 (0.100)	3,96 (0.156)

Figure D.20 — SR13.3 Seal-ring coupling and non-metallic ring for non-upset tubing

Dimensions in millimetres (inches)

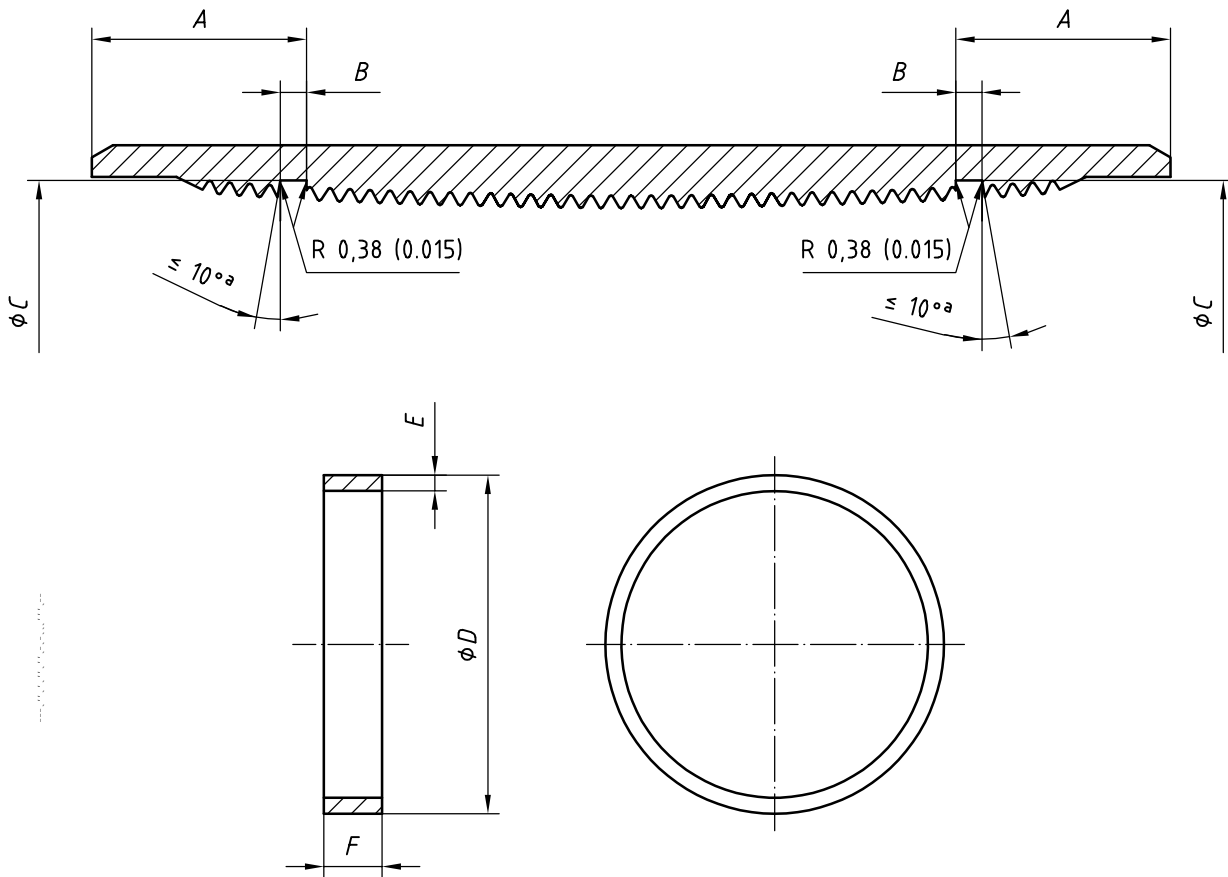

Seal ring groove and thread pitch diameter shall be concentric within 0,51 mm (0.020 in) of indicated thread run-out.

<sup>a</sup> Angle optional.

EUE tubing size Label 1	Outside diameter	Coupling dimensions mm (in)			Ring dimensions mm (in)		
		A ± 3,2 (± 0.125)	B ± 0,13 (± 0.005)	C ± 0,25 (± 0.010)	D ± 0,19 (± 0.075)	E +0,13 0 (+0.005) 0	F +0,38 0 (+0.015) 0
1	2	3	4	5	6	7	8
1.050	26,67	22,2 (0.875)	3,96 (0.156)	34,09 (1.342)	34,54 (1.360)	2,03 (0.080)	3,18 (0.125)
1.315	33,40	22,2 (0.875)	3,96 (0.156)	38,00 (1.496)	38,43 (1.513)	2,03 (0.080)	3,18 (0.125)
1.660	42,16	22,2 (0.875)	4,78 (0.188)	46,74 (1.840)	47,17 (1.857)	2,03 (0.080)	3,96 (0.156)
1.900	48,26	22,2 (0.875)	4,78 (0.188)	53,87 (2.121)	54,31 (2.138)	2,03 (0.080)	3,96 (0.156)
2-3/8	60,32	28,6 (1.125)	4,78 (0.188)	66,60 (2.622)	67,06 (2.640)	2,54 (0.100)	3,96 (0.156)
2-7/8	73,02	28,6 (1.125)	4,78 (0.188)	79,30 (3.122)	79,76 (3.140)	2,54 (0.100)	3,96 (0.156)
3-1/2	88,90	28,6 (1.125)	4,78 (0.188)	95,96 (3.778)	96,42 (3.796)	2,54 (0.100)	3,96 (0.156)
4	101,60	28,6 (1.125)	4,78 (0.188)	108,66 (4.278)	109,12 (4.296)	2,54 (0.100)	3,96 (0.156)
4-1/2	114,30	28,6 (1.125)	4,78 (0.188)	121,36 (4.778)	121,82 (4.796)	2,54 (0.100)	3,96 (0.156)

Figure D.21 — SR13.4 Seal-ring coupling and non-metallic ring for upset tubing



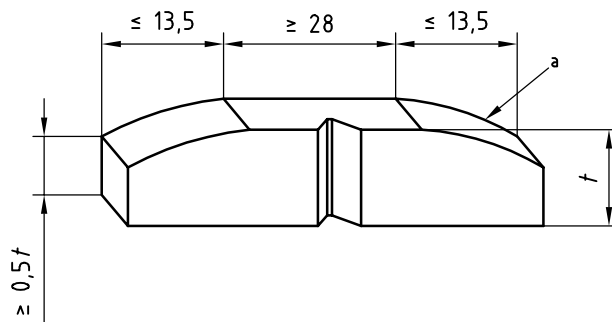

a Outside diameter curvature.

Figure D.22 — SR16.1

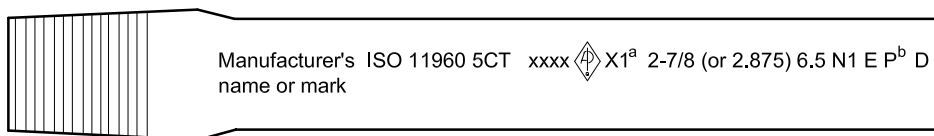

**Stencil marking** [beginning at least 0,6 m (2 ft) from either externally threaded end]

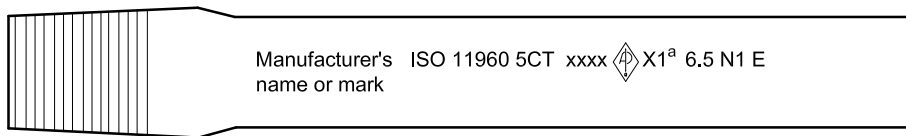

**Stamp marking — Optional** [within approximately 0,3 m (1 ft) of either externally threaded end]

**a) EXAMPLE 1 — Tubing** Label 1: 2-7/8, Label 2: 6.5, Grade N80 Type 1, electric weld, external upset, threaded (by the manufacturer) pin-by-pin without couplings. January 1999.

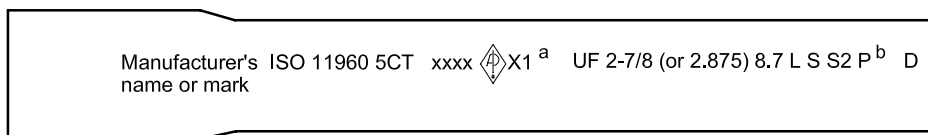

**Stencil marking** [beginning at least 0,6 m (2 ft) from either end]

**b) EXAMPLE 2 — Tubing** Label 1: 2-7/8, Label 2: 8.7, Grade L80 Type 1, seamless, external upset, plain end. Additional requirements include hydrostatic testing to 94,5 MPa (13 700 psi) and inspection to SR2. January 1999.

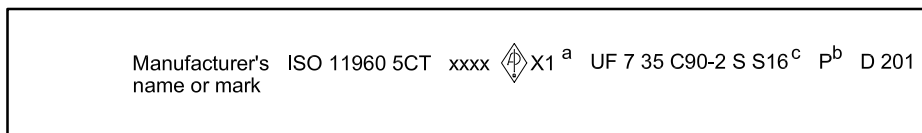

**Stencil marking** [beginning at least 0,6 m (2 ft) from either end]



**Stamp marking — Optional** [within approximately 0,3 m (1 ft) from either end]

**c) EXAMPLE 3 — Casing** Label 1: 7, Label 2: 35, Grade C90 Type 2, seamless, plain end, serial number 201. Supplementary requirement 16 (SR16) for test at -10 °C (+14 °F). The pipe was pressure-tested to 69 MPa (10 000 psi). February 2000.

**Figure D.23 — Examples of marking requirements and sequence for manufacturers and threaders using the API monogram, Annex F and Table C.81 or E.81**

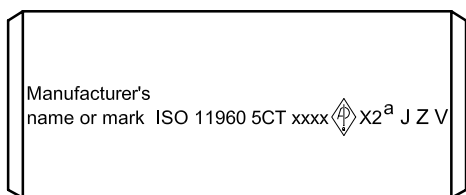

**Stencil marking**

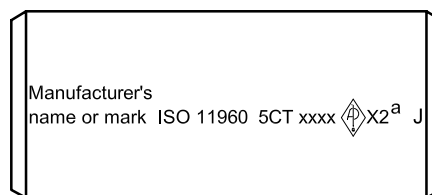

**Stamp marking — Optional**

NOTE Marking in the centre of coupling may be stamped in either the longitudinal or transverse direction.

**d) EXAMPLE 4 — Tubing coupling** for Label 2-7/8, Grade J55, normalized upset (or non-upset) tubing, only visual inspection required. April 2000.

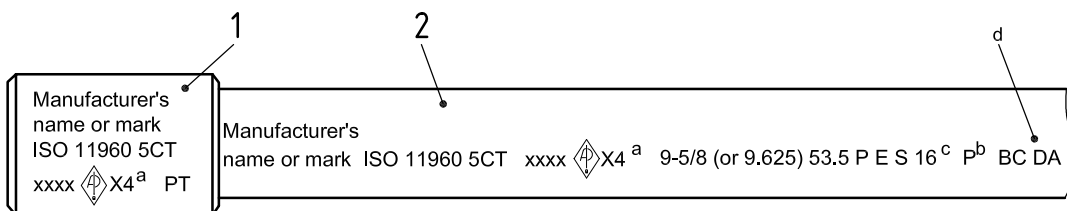

**Stencil marking** [beginning not less than 0,6 m (2 ft) from the coupling]

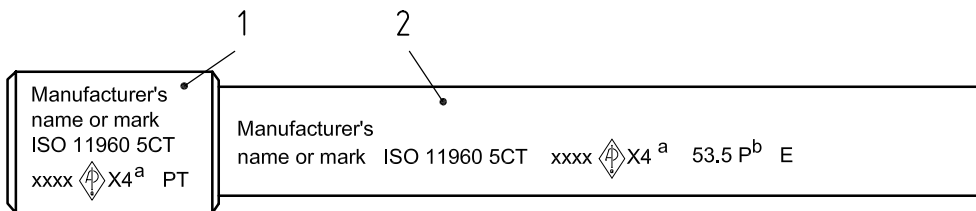

**Stamp marking — Optional** [within approximately 0,3 m (1 ft) from the coupling]

NOTE Marking in the centre of the coupling may be in either the longitudinal or transverse direction.

**e) EXAMPLE 5 — Buttress casing with coupling:** Label 1: 9-5/8, Label 2: 53.5, Grade P110, electric weld; supplementary requirements are SR11 and SR16 for test at  $-18\text{ }^{\circ}\text{C}$  ( $0\text{ }^{\circ}\text{F}$ ) and 215,9 mm (8.500 in) drift test. Coupling is tin-plated. December 1999.

**Figure D.23 — Examples of marking requirements and sequence for manufacturers and threaders using the API monogram, Annex F and Table C.81 or E.81 (continued)**

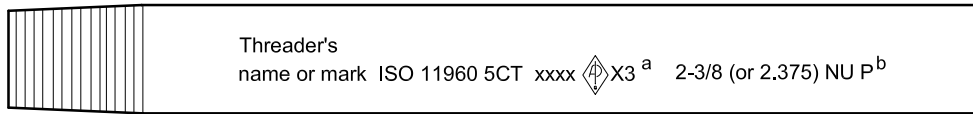

**Stencil marking (adjacent to the threads)**

Threader stencil marking shall be placed adjacent to the threads and is in addition to marking applied by other pipe manufacturers.

**f) EXAMPLE 6 — Threader:** Label 1: 2-3/8, Label 2: 4, Grade J55 non-upset thread, and hydrostatically tested to alternative test pressure of 43,5 MPa (6 300 psi). July 1999.

**Key**

- 1 coupling
- 2 pipe

- <sup>a</sup> API license number, API monogram, date of manufacture (see Annex F).
- <sup>b</sup> Express pressure in megapascals for pipe manufactured to SI units and in pounds per square inch for pipe manufactured to USC units.
- <sup>c</sup> Express the CVN requirements in joules and the temperature in degrees Celsius for pipe manufactured to SI units, and in foot-pounds and degrees Fahrenheit for pipe manufactured to USC units.
- <sup>d</sup> Express alternative drift diameter in millimetres for pipe manufactured to SI units and in inches for pipe manufactured to USC units.

**Figure D.23 — Examples of marking requirements and sequence for manufacturers and threaders using the API monogram, Annex F and Table C.81 or E.81 (continued)**

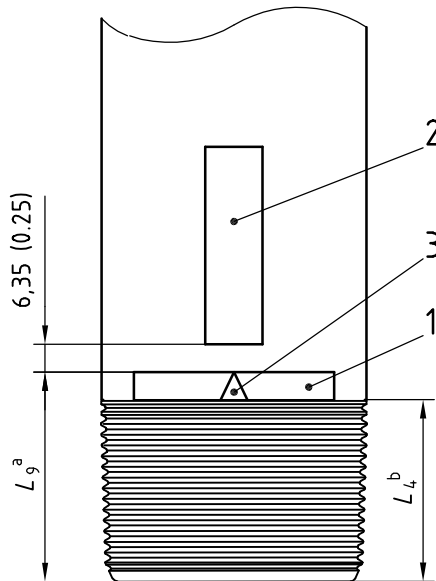

**Key**

- 1 paint mark, of high visibility green colour
- 2 paint stripe, approximately 25 mm (1 in) wide and approximately 0,6 m (2 ft) long for the pin end and not less than 100 mm (4 in) long when a coupling is installed by the manufacturer
- 3 triangle stamp

<sup>a</sup> Maximum make-up length: end of pipe to triangle apex.

<sup>b</sup> Total length: end of pipe to vanish point.

Triangle stamp location		
Label 1	$L_4$	$L_9$ $\begin{matrix} 0 \\ -1,59 \text{ mm} \\ \left( \begin{matrix} 0 \\ -1/16 \text{ in} \end{matrix} \right) \end{matrix}$
1	2	3
4-1/2	76,20 (3.000)	82,55 (3.250)
5	85,73 (3.375)	92,11 (3.625)
5-1/2	88,90 (3.500)	95,25 (3.750)
6-5/8	98,43 (3.875)	104,78 (4.125)
7	101,60 (4.000)	107,95 (4.250)
7-5/8	104,78 (4.125)	111,13 (4.375)
8-5/8	114,30 (4.500)	120,65 (4.750)
9-5/8	120,65 (4.750)	127,00 (5.000)

**Figure D.24 — SR22-1 Field-end paint mark and triangle stamp (stamp on mill and field ends)**

Dimensions in millimetres (inches)

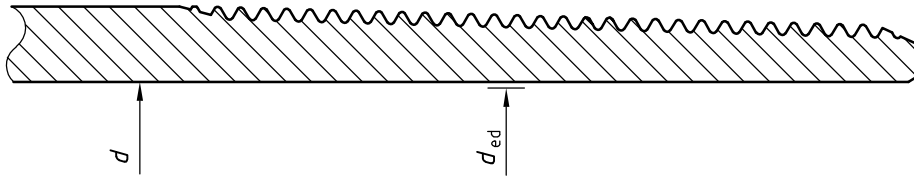

a) Option 1

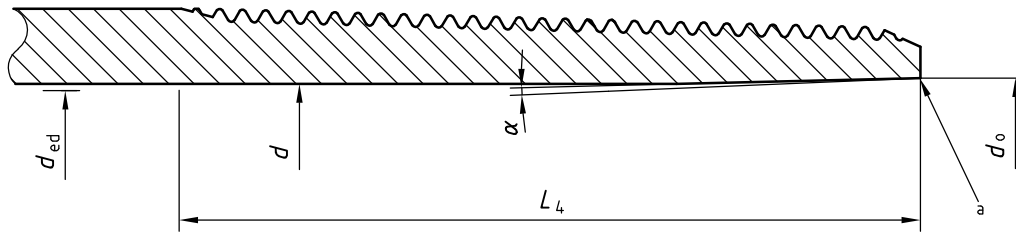

b) Option 2

a Break edge.

Option 1			
Non-bored inside diameter			
Label 1	Label 2	Special end drift diameter $d_{ed}$ $\pm 0,13$ ( $\pm 0.005$ )	Inside diameter $d$
1	2	3	4
7	23.00	160,68 (6.326)	161,70 (6.366)
7	32.00	154,18 (6.070)	154,79 (6.094)
8-5/8	32.00	201,96 (7.951)	201,19 (7.921)
8-5/8	40.00	195,61 (7.701)	196,22 (7.725)
9-5/8	40.00	224,18 (8.826)	224,41 (8.835)
9-5/8	47.00	221,01 (8.701)	220,50 (8.681)
9-5/8	53.50	217,83 (8.576)	216,79 (8.535)

Option 2						
Bored inside diameter						
Label 1	Label 2	Special end drift diameter $d_{ed}$ $\pm 0,13$ ( $\pm 0.005$ )	Inside diameter $d$	Chamfer depth $L_4$ max.	Chamfer diameter $d_0$ $\pm 0,38$ ( $\pm 0.015$ )	Chamfer angle $\alpha$
1	2	3	4	5	6	7
7	23.00	158,75 (6.250)	161,70 (6.366)	101,60 (4.000)	162,56 (6.400)	2° to 15°
7	32.00	152,40 (6.000)	154,79 (6.094)	101,60 (4.000)	157,48 (6.200)	2° to 15°
8-5/8	32.00	200,02 (7.875)	201,19 (7.921)	114,30 (4.500)	204,47 (8.050)	2° to 15°
8-5/8	40.00	193,68 (7.625)	196,22 (7.725)	114,30 (4.500)	198,12 (7.800)	2° to 15°
9-5/8	40.00	222,25 (8.750)	224,41 (8.835)	120,65 (4.750)	227,33 (8.950)	2° to 15°
9-5/8	47.00	219,08 (8.625)	220,50 (8.681)	120,65 (4.750)	223,52 (8.800)	2° to 15°
9-5/8	53.50	215,90 (8.500)	216,79 (8.535)	120,65 (4.750)	220,98 (8.700)	2° to 15°

Figure D.25 — SR22-2 Optional tapered bore along inside diameter specifications

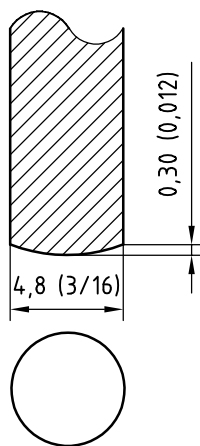

a) Rounded contact point

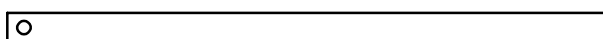

b) Top view



c) Side view

Figure D.26 — Example of a typical 90° hook-type tool

Dimensions in millimetres (inches)

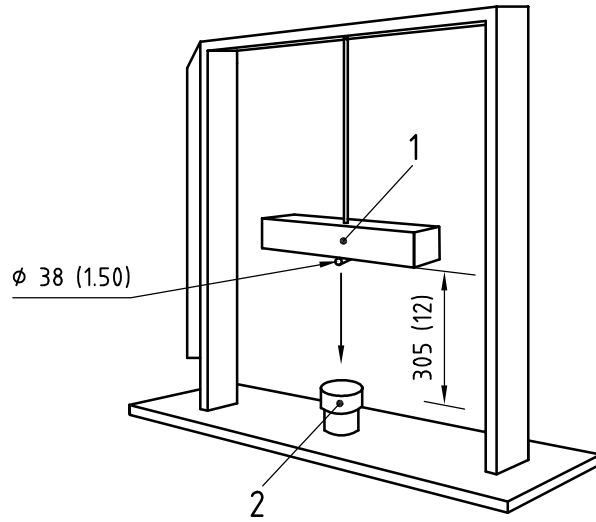

**Key**

- 1 steel bar
- 2 test-piece set

**Figure D.27 — Axial impact test apparatus**

Dimensions in millimetres (inches)

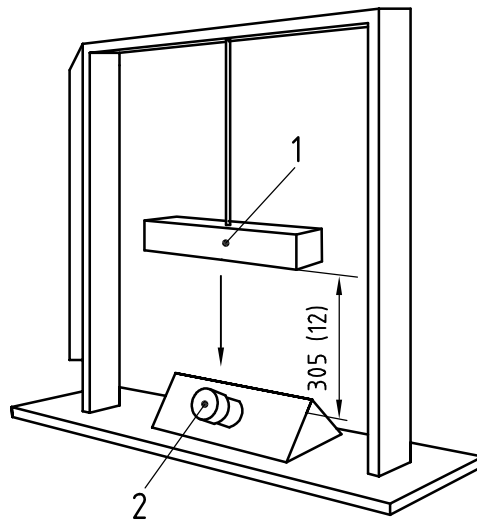

**Key**

- 1 flat steel plate
- 2 test-piece set

**Figure D.28 — 45° impact test apparatus**



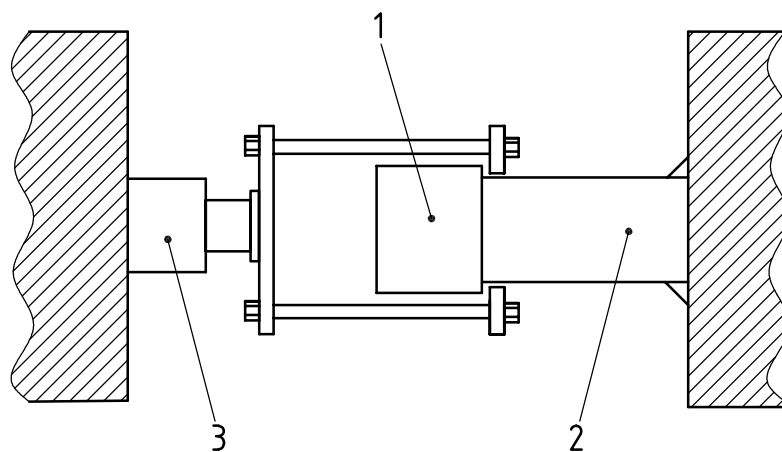

**Key**

- 1 thread protector
- 2 pipe section
- 3 hydraulic cylinder

**Figure D.29 — Stripping test apparatus**

## Annex E (normative)

### Tables in USC units

**Table E.1 — ISO/API casing list  
Sizes, masses, wall thickness, grade and applicable end-finish**

Labels <sup>a</sup>		Outside diameter <i>D</i> in	Nominal linear mass <sup>b, c</sup> T&C lb/ft	Wall thickness <i>t</i> in	Type of end-finish							
					H40	J55 K55	M65	L80 C95	N80 Type 1,Q	C90 T95	P110	Q125
1	2	3	4	5	6	7	8	9	10	11	12	13
4-1/2	9.50	4.500	9.50	0.205	PS	PS	PS	—	—	—	—	—
4-1/2	10.50	4.500	10.50	0.224	—	PSB	PSB	—	—	—	—	—
4-1/2	11.60	4.500	11.60	0.250	—	PSLB	PLB	PLB	PLB	PLB	PLB	—
4-1/2	13.50	4.500	13.50	0.290	—	—	PLB	PLB	PLB	PLB	PLB	—
4-1/2	15.10	4.500	15.10	0.337	—	—	—	—	—	—	PLB	PLB
5	11.50	5.000	11.50	0.220	—	PS	PS	—	—	—	—	—
5	13.00	5.000	13.00	0.253	—	PSLB	PSLB	—	—	—	—	—
5	15.00	5.000	15.00	0.296	—	PSLBE	PLB	PLBE	PLBE	PLBE	PLBE	—
5	18.00	5.000	18.00	0.362	—	—	PLB	PLBE	PLBE	PLBE	PLBE	PLBE
5	21.40	5.000	21.40	0.437	—	—	PLB	PLB	PLB	PLB	PLB	PLB
5	23.20	5.000	23.20	0.478	—	—	—	PLB	PLB	PLB	PLB	PLB
5	24.10	5.000	24.10	0.500	—	—	—	PLB	PLB	PLB	PLB	PLB
5-1/2	14.00	5.500	14.00	0.244	PS	PS	PS	—	—	—	—	—
5-1/2	15.50	5.500	15.50	0.275	—	PSLBE	PSLB	—	—	—	—	—
5-1/2	17.00	5.500	17.00	0.304	—	PSLBE	PLB	PLBE	PLBE	PLBE	PLBE	—
5-1/2	20.00	5.500	20.00	0.361	—	—	PLB	PLBE	PLBE	PLBE	PLBE	—
5-1/2	23.00	5.500	23.00	0.415	—	—	PLB	PLBE	PLBE	PLBE	PLBE	PLBE
5-1/2	26.80	5.500	26.80	0.500	—	—	—	—	—	P	—	—
5-1/2	29.70	5.500	29.70	0.562	—	—	—	—	—	P	—	—
5-1/2	32.60	5.500	32.60	0.625	—	—	—	—	—	P	—	—
5-1/2	35.30	5.500	35.30	0.687	—	—	—	—	—	P	—	—
5-1/2	38.00	5.500	38.00	0.750	—	—	—	—	—	P	—	—
5-1/2	40.50	5.500	40.50	0.812	—	—	—	—	—	P	—	—
5-1/2	43.10	5.500	43.10	0.875	—	—	—	—	—	P	—	—
6-5/8	20.00	6.625	20.00	0.288	PS	PSLB	PSLB	—	—	—	—	—
6-5/8	24.00	6.625	24.00	0.352	—	PSLBE	PLB	PLBE	PLBE	PLBE	PLBE	—
6-5/8	28.00	6.625	28.00	0.417	—	—	PLB	PLBE	PLBE	PLBE	PLBE	—
6-5/8	32.00	6.625	32.00	0.475	—	—	—	PLBE	PLBE	PLBE	PLBE	PLBE
7	17.00	7.000	17.00	0.231	PS	—	—	—	—	—	—	—
7	20.00	7.000	20.00	0.272	PS	PS	PS	—	—	—	—	—
7	23.00	7.000	23.00	0.317	—	PSLBE	PLB	PLBE	PLBE	PLBE	—	—
7	26.00	7.000	26.00	0.362	—	PSLBE	PLB	PLBE	PLBE	PLBE	PLBE	—
7	29.00	7.000	29.00	0.408	—	—	PLB	PLBE	PLBE	PLBE	PLBE	—
7	32.00	7.000	32.00	0.453	—	—	PLB	PLBE	PLBE	PLBE	PLBE	—
7	35.00	7.000	35.00	0.498	—	—	—	PLBE	PLBE	PLBE	PLBE	PLBE
7	38.00	7.000	38.00	0.540	—	—	—	PLBE	PLBE	PLBE	PLBE	PLBE
7	42.70	7.000	42.70	0.625	—	—	—	—	—	P	—	—
7	46.40	7.000	46.40	0.687	—	—	—	—	—	P	—	—
7	50.10	7.000	50.10	0.750	—	—	—	—	—	P	—	—
7	53.60	7.000	53.60	0.812	—	—	—	—	—	P	—	—
7	57.10	7.000	57.10	0.875	—	—	—	—	—	P	—	—

See notes at end of table.

Table E.1 (continued)

Labels <sup>a</sup>		Outside diameter <i>D</i> in	Nominal linear mass <sup>b, c</sup> T&C lb/ft	Wall thickness <i>t</i> in	Type of end-finish							
1	2				H40	J55 K55	M65	L80 C95	N80 Type 1,Q	C90 T95	P110	Q125
1	2	3	4	5	6	7	8	9	10	11	12	13
7-5/8	24.00	7.625	24.00	0.300	PS	—	—	—	—	—	—	—
7-5/8	26.20	7.625	26.40	0.328	—	PSLBE	PSLB	PLBE	PLBE	PLBE	—	—
7-5/8	29.70	7.625	29.70	0.375	—	—	PLB	PLBE	PLBE	PLBE	PLBE	—
7-5/8	33.70	7.625	33.70	0.430	—	—	PLB	PLBE	PLBE	PLBE	PLBE	—
7-5/8	39.00	7.625	39.00	0.500	—	—	—	PLBE	PLBE	PLBE	PLBE	PLBE
7-5/8	42.80	7.625	42.80	0.562	—	—	—	PLB	PLB	PLB	PLB	PLB
7-5/8	45.30	7.625	45.30	0.595	—	—	—	PLB	PLB	PLB	PLB	PLB
7-5/8	47.10	7.625	47.10	0.625	—	—	—	PLB	PLB	PLB	PLB	PLB
7-5/8	51.20	7.625	51.20	0.687	—	—	—	—	—	P	—	—
7-5/8	55.30	7.625	55.30	0.750	—	—	—	—	—	P	—	—
7-3/4	46.10	7.750	46.10	0.595	—	—	—	P	P	P	P	P
8-5/8	24.00	8.625	24.00	0.264	—	PS	PS	—	—	—	—	—
8-5/8	28.00	8.625	28.00	0.304	PS	—	PS	—	—	—	—	—
8-5/8	32.00	8.625	32.00	0.352	PS	PSLBE	PSLB	—	—	—	—	—
8-5/8	36.00	8.625	36.00	0.400	—	PSLBE	PSLB	PLBE	PLBE	PLBE	—	—
8-5/8	40.00	8.625	40.00	0.450	—	—	PLB	PLBE	PLBE	PLBE	PLBE	—
8-5/8	44.00	8.625	44.00	0.500	—	—	—	PLBE	PLBE	PLBE	PLBE	—
8-5/8	49.00	8.625	49.00	0.557	—	—	—	PLBE	PLBE	PLBE	PLBE	PLBE
9-5/8	32.30	9.625	32.30	0.312	PS	—	—	—	—	—	—	—
9-5/8	36.00	9.625	36.00	0.352	PS	PSLB	PSLB	—	—	—	—	—
9-5/8	40.00	9.625	40.00	0.395	—	PSLBE	PSLB	PLBE	PLBE	PLBE	—	—
9-5/8	43.50	9.625	43.50	0.435	—	—	PLB	PLBE	PLBE	PLBE	PLBE	—
9-5/8	47.00	9.625	47.00	0.472	—	—	PLB	PLBE	PLBE	PLBE	PLBE	PLBE
9-5/8	53.50	9.625	53.50	0.545	—	—	—	PLBE	PLBE	PLBE	PLBE	PLBE
9-5/8	58.40	9.625	58.40	0.595	—	—	—	PLB	PLB	PLB	PLB	PLB
9-5/8	59.40	9.625	59.40	0.609	—	—	—	—	—	P	—	—
9-5/8	64.90	9.625	64.90	0.672	—	—	—	—	—	P	—	—
9-5/8	70.30	9.625	70.30	0.734	—	—	—	—	—	P	—	—
9-5/8	75.60	9.625	75.60	0.797	—	—	—	—	—	P	—	—
10-3/4	32.75	10.750	32.75	0.279	PS	—	—	—	—	—	—	—
10-3/4	40.50	10.750	40.50	0.350	PS	PSB	PSB	—	—	—	—	—
10-3/4	45.50	10.750	45.50	0.400	—	PSBE	PSB	—	—	—	—	—
10-3/4	51.00	10.750	51.00	0.450	—	PSBE	PSB	PSBE	PSBE	PSBE	PSBE	—
10-3/4	55.50	10.750	55.50	0.495	—	—	PSB	PSBE	PSBE	PSBE	PSBE	—
10-3/4	60.70	10.750	60.70	0.545	—	—	—	—	—	PSBE	PSBE	PSBE
10-3/4	65.70	10.750	65.70	0.595	—	—	—	—	—	PSB	PSB	PSB
10-3/4	73.20	10.750	73.20	0.672	—	—	—	—	—	P	—	—
10-3/4	79.20	10.750	79.20	0.734	—	—	—	—	—	P	—	—
10-3/4	85.30	10.750	85.30	0.797	—	—	—	—	—	P	—	—
11-3/4	42.00	11.750	42.00	0.333	PS	—	—	—	—	—	—	—
11-3/4	47.00	11.750	47.00	0.375	—	PSB	PSB	—	—	—	—	—
11-3/4	54.00	11.750	54.00	0.435	—	PSB	PSB	—	—	—	—	—
11-3/4	60.00	11.750	60.00	0.489	—	PSB	PSB	PSB	PSB	PSB	PSB	PSB
11-3/4	65.00	11.750	65.00	0.534	—	—	—	P	P	P	P	P
11-3/4	71.00	11.750	71.00	0.582	—	—	—	P	P	P	P	P
13-3/8	48.00	13.375	48.00	0.330	PS	—	—	—	—	—	—	—
13-3/8	54.50	13.375	54.50	0.380	—	PSB	PSB	—	—	—	—	—
13-3/8	61.00	13.375	61.00	0.430	—	PSB	PSB	—	—	—	—	—
13-3/8	68.00	13.375	68.00	0.480	—	PSB	PSB	PSB	PSB	PSB	PSB	—
13-3/8	72.00	13.375	72.00	0.514	—	—	—	PSB	PSB	PSB	PSB	PSB

See notes at end of table.

**Table E.1 (continued)**

Labels <sup>a</sup>		Outside diameter <i>D</i> in	Nominal linear mass <sup>b, c</sup> T&C lb/ft	Wall thickness <i>t</i> in	Type of end-finish							
1	2				H40	J55 K55	M65	L80 C95	N80 Type 1,Q	C90 T95	P110	Q125
1	2	3	4	5	6	7	8	9	10	11	12	13
16	65.00	16.000	65.00	0.375	PS	—	—	—	—	—	—	—
16	75.00	16.000	75.00	0.438	—	PSB	PSB	—	—	—	—	—
16	84.00	16.000	84.00	0.495	—	PSB	PSB	—	—	—	—	—
16	109.00	16.000	109.00	0.656	—	P	—	P	P	—	P	P
18-5/8	87.50	18.625	87.50	0.435	PS	PSB	PSB	—	—	—	—	—
20	94.00	20.000	94.00	0.438	PSL	PSLB	PSLB	—	—	—	—	—
20	106.50	20.000	106.50	0.500	—	PSLB	PSLB	—	—	—	—	—
20	133.00	20.000	133.00	0.635	—	PSLB	—	—	—	—	—	—

P = Plain end, S = Short round thread, L = Long round thread, B = Buttress thread, E = Extreme-line.

<sup>a</sup> Labels are for information and assistance in ordering.

<sup>b</sup> Nominal linear masses, threaded and coupled (col. 2) are shown for information only.

<sup>c</sup> The densities of martensitic chromium steels (L80 types 9Cr and 13Cr) are different from carbon steels. The masses shown are therefore not accurate for martensitic chromium steels. A mass correction factor of 0,989 may be used.

**Table E.2 — ISO/API plain-end casing liner list — Grade J55**

Labels		Size Outside diameter <i>D</i> in	Plain-end linear mass lb/ft	Wall thickness <i>t</i> in
1	2			
1	2	3	4	5
3-1/2	9.91	3.500	9.91	0.289
4	11.34	4.000	11.34	0.286
4-1/2	13.04	4.500	13.04	0.290
5	17.93	5.000	17.93	0.362
5-1/2	19.81	5.500	19.81	0.361
6-5/8	27.65	6.625	27.65	0.417

**Table E.3 — ISO/API tubing list**  
**Sizes, masses, wall thickness, grade and applicable end-finish**

Labels				Outside diameter <i>D</i> in	Nominal linear masses <sup>a, b</sup>			Wall thickness <i>t</i> in	Type of end-finish <sup>c</sup>						
1	2				Non-upset T&C lb/ft	Ext. upset T&C lb/ft	Integ. joint lb/ft		H40	J55	L80	N80 Type1, Q	C90	T95	P110
	NU T&C	EU T&C	IJ	10				11							
1.050	1.14	1.20	—	1.050	1.14	1.20	—	0.113	PNU	PNU	PNU	PNU	PNU	PNU	—
1.050	1.48	1.54	—	1.050	1.48	1.54	—	0.154	PU	PU	PU	PU	PU	PU	PU
1.315	1.70	1.80	1.72	1.315	1.70	1.80	1.72	0.133	PNUI	PNUI	PNUI	PNUI	PNUI	PNUI	—
1.315	2.19	2.24	—	1.315	2.19	2.24	—	0.179	PU	PU	PU	PU	PU	PU	PU
1.660	2.09	—	2.10	1.660	—	—	2.10	0.125	PI	PI	—	—	—	—	—
1.660	2.30	2.40	2.33	1.660	2.30	2.40	2.33	0.140	PNUI	PNUI	PNUI	PNUI	PNUI	PNUI	—
1.660	3.03	3.07	—	1.660	3.03	3.07	—	0.191	PU	PU	PU	PU	PU	PU	PU
1.900	2.40	—	2.40	1.900	—	—	2.40	0.125	PI	PI	—	—	—	—	—
1.900	2.75	2.90	2.76	1.900	2.75	2.90	2.76	0.145	PNUI	PNUI	PNUI	PNUI	PNU I	PNUI	—
1.900	3.65	3.73	—	1.900	3.65	3.73	—	0.200	PU	PU	PU	PU	PU	PU	PU
1.900	4.42	—	—	1.900	4.42	—	—	0.250	—	—	P	—	P	P	—
1.900	5.15	—	—	1.900	5.15	—	—	0.300	—	—	P	—	P	P	—
2.063	3.24	—	3.25	2.063	—	—	3.25	0.156	PI	PI	PI	PI	PI	PI	—
2.063	4.50	—	—	2.063	4.50	—	—	0.225	P	P	P	P	P	P	P
2-3/8	4.00	—	—	2.375	4.00	—	—	0.167	PN	PN	PN	PN	PN	PN	—
2-3/8	4.60	4.70	—	2.375	4.60	4.70	—	0.190	PNU	PNU	PNU	PNU	PNU	PNU	PNU
2-3/8	5.80	5.95	—	2.375	5.80	5.95	—	0.254	—	—	PNU	PNU	PNU	PNU	PNU
2-3/8	6.60	—	—	2.375	6.60	—	—	0.295	—	—	P	—	P	P	—
2-3/8	7.35	7.45	—	2.375	7.35	7.45	—	0.336	—	—	PU	—	PU	PU	—
2-7/8	6.40	6.50	—	2.875	6.40	6.50	—	0.217	PNU	PNU	PNU	PNU	PNU	PNU	PNU
2-7/8	7.80	7.90	—	2.875	7.80	7.90	—	0.276	—	—	PNU	PNU	PNU	PNU	PNU
2-7/8	8.60	8.70	—	2.875	8.60	8.70	—	0.308	—	—	PNU	PNU	PNU	PNU	PNU
2-7/8	9.35	9.45	—	2.875	9.35	9.45	—	0.340	—	—	PU	—	PU	PU	—
2-7/8	10.50	—	—	2.875	10.50	—	—	0.392	—	—	P	—	P	P	—
2-7/8	11.50	—	—	2.875	11.50	—	—	0.440	—	—	P	—	P	P	—
3-1/2	7.70	—	—	3.500	7.70	—	—	0.216	PN	PN	PN	PN	PN	PN	—
3-1/2	9.20	9.30	—	3.500	9.20	9.30	—	0.254	PNU	PNU	PNU	PNU	PNU	PNU	PNU
3-1/2	10.20	—	—	3.500	10.20	—	—	0.289	PN	PN	PN	PN	PN	PN	—
3-1/2	12.70	12.95	—	3.500	12.70	12.95	—	0.375	—	—	PNU	PNU	PNU	PNU	PNU
3-1/2	14.30	—	—	3.500	14.30	—	—	0.430	—	—	P	—	P	P	—
3-1/2	15.50	—	—	3.500	15.50	—	—	0.476	—	—	P	—	P	P	—
3-1/2	17.00	—	—	3.500	17.00	—	—	0.530	—	—	P	—	P	P	—
4	9.50	—	—	4.000	9.50	—	—	0.226	PN	PN	PN	PN	PN	PN	—
4	10.70	11.00	—	4.000	—	11.00	—	0.262	PU	PU	PU	PU	PU	PU	—
4	13.20	—	—	4.000	13.20	—	—	0.330	—	—	P	—	P	P	—
4	16.10	—	—	4.000	16.10	—	—	0.415	—	—	P	—	P	P	—
4	18.90	—	—	4.000	18.90	—	—	0.500	—	—	P	—	P	P	—
4	22.20	—	—	4.000	22.20	—	—	0.610	—	—	P	—	P	P	—
4-1/2	12.60	12.75	—	4.500	12.60	12.75	—	0.271	PNU	PNU	PNU	PNU	PNU	PNU	—
4-1/2	15.20	—	—	4.500	15.20	—	—	0.337	—	—	P	—	P	P	—
4-1/2	17.00	—	—	4.500	17.00	—	—	0.380	—	—	P	—	P	P	—
4-1/2	18.90	—	—	4.500	18.90	—	—	0.430	—	—	P	—	P	P	—
4-1/2	21.50	—	—	4.500	21.50	—	—	0.500	—	—	P	—	P	P	—
4-1/2	23.70	—	—	4.500	23.70	—	—	0.560	—	—	P	—	P	P	—
4-1/2	26.10	—	—	4.500	26.10	—	—	0.630	—	—	P	—	P	P	—

P = Plain end, N = Non-upset threaded and coupled, U = External upset threaded and coupled, I = Integral joint.

<sup>a</sup> Nominal linear masses, threads and coupling (col. 2, 3, 4) are shown for information only.

<sup>b</sup> The densities of martensitic chromium steels (L80 types 9Cr and 13Cr) are different from carbon steels. The masses shown are therefore not accurate for martensitic chromium steels. A mass correction factor of 0.989 may be used.

<sup>c</sup> Non-upset tubing is available with regular couplings or special bevel couplings. External-upset tubing is available with regular, special-bevel, or special-clearance couplings.

**Table E.4 — Process of manufacture and heat treatment**

Group	Grade	Type	Manufacturing process <sup>a</sup>	Heat treatment	Tempering temperature °F min.
1	2	3	4	5	6
1	H40	—	S or EW	None	—
	J55	—	S or EW	None <sup>b</sup>	—
	K55	—	S or EW	None <sup>b</sup>	—
	N80	1	S or EW	<sup>c</sup>	—
	N80	Q	S or EW	Q&T	—
2	M65	—	S or EW	<sup>d</sup>	—
	L80	1	S or EW	Q&T	1 050
	L80	9Cr	S	Q&T <sup>e</sup>	1 100
	L80	13Cr	S	Q&T <sup>e</sup>	1 100
	C90	1	S	Q&T	1 150
	C90	2	S	Q&T	1 150
	C95	—	S or EW	Q&T	1 000
	T95	1	S	Q&T	1 200
	T95	2	S	Q&T	1 200
3	P110	—	S or EW <sup>f, g</sup>	Q&T	—
4	Q125	1	S or EW <sup>g</sup>	Q&T	—
	Q125	2	S or EW <sup>g</sup>	Q&T	—
	Q125	3	S or EW <sup>g</sup>	Q&T	—
	Q125	4	S or EW <sup>g</sup>	Q&T	—

<sup>a</sup> S = seamless process; EW = electric-welded process.

<sup>b</sup> Full length normalized (N), normalized and tempered (N&T), or quenched and tempered (Q&T), at the manufacturer's option or as specified on the purchase agreement.

<sup>c</sup> Full length normalized or normalized and tempered at the manufacturer's option.

<sup>d</sup> All pipe shall be full body heat-treated. Full length normalized (N), normalized and tempered (N&T), or quenched and tempered (Q&T), at the manufacturer's option or as specified on the purchase agreement.

<sup>e</sup> Types 9Cr and 13Cr may be air-quenched.

<sup>f</sup> Special chemical requirements for electric-welded P110 casing are specified in Table C.5.

<sup>g</sup> Special requirements unique to electric-welded P110 and Q125 are specified in A.6 (SR11).

**Table E.5 — Chemical composition, mass fraction (%)**

Group	Grade	Type	C		Mn		Mo		Cr		Ni	Cu	P	S	Si
			min.	max.	min.	max.	min.	max.	min.	max.	max.	max.	max.	max.	max.
1	2	3	4	5	6	7	8	9	10	11	12	13	14	15	16
1	H40	—	—	—	—	—	—	—	—	—	—	—	0.030	0.030	—
	J55	—	—	—	—	—	—	—	—	—	—	—	0.030	0.030	—
	K55	—	—	—	—	—	—	—	—	—	—	—	0.030	0.030	—
	N80	1	—	—	—	—	—	—	—	—	—	—	0.030	0.030	—
	N80	Q	—	—	—	—	—	—	—	—	—	—	0.030	0.030	—
2	M65	—	—	—	—	—	—	—	—	—	—	—	0.030	0.030	—
	L80	1	—	0.43 <sup>a</sup>	—	1.90	—	—	—	—	0.25	0.35	0.030	0.030	0.45
	L80	9Cr	—	0.15	0.30	0.60	0.90	1.10	8.00	10.0	0.50	0.25	0.020	0.010	1.00
	L80	13Cr	0.15	0.22	0.25	1.00	—	—	12.0	14.0	0.50	0.25	0.020	0.010	1.00
	C90	1	—	0.35	—	1.20	0.25 <sup>b</sup>	0.85	—	1.50	0.99	—	0.020	0.010	—
	C90	2	—	0.50	—	1.90	—	NL	—	NL	0.99	—	0.030	0.010	—
	C95	—	—	0.45 <sup>c</sup>	—	1.90	—	—	—	—	—	—	0.030	0.030	0.45
	T95	1	—	0.35	—	1.20	0.25 <sup>d</sup>	0.85	0.40	1.50	0.99	—	0.020	0.010	—
T95	2	—	0.50	—	1.90	—	—	—	—	0.99	—	0.030	0.010	—	
3	P110	<sup>e</sup>	—	—	—	—	—	—	—	—	—	—	0.030 <sup>e</sup>	0.030 <sup>e</sup>	—
4	Q125	1	—	0.35	—	1.35	—	0.85	—	1.50	0.99	—	0.020	0.010	—
	Q125	2	—	0.35	—	1.00	—	NL	—	NL	0.99	—	0.020	0.020	—
	Q125	3	—	0.50	—	1.90	—	NL	—	NL	0.99	—	0.030	0.010	—
	Q125	4	—	0.50	—	1.90	—	NL	—	NL	0.99	—	0.030	0.020	—

<sup>a</sup> The carbon content for L80 may be increased up to 0.50 % max. if the product is oil-quenched.  
<sup>b</sup> The molybdenum content for Grade C90 Type 1 has no minimum tolerance if the wall thickness is less than 0.700 in.  
<sup>c</sup> The carbon content for C95 may be increased up to 0.55 % max. if the product is oil-quenched.  
<sup>d</sup> The molybdenum content for T95 Type 1 may be decreased to 0.15 % min. if the wall thickness is less than 0.700 in.  
<sup>e</sup> For EW Grade P110, the phosphorus content shall be 0.020 % max. and the sulfur content 0.010 % max.  
 NL = no limit. Elements shown shall be reported in product analysis.

**Table E.6 — Tensile and hardness requirements**

Group	Grade	Type	Total elongation under load %	Yield strength ksi		Tensile strength min. ksi	Hardness <sup>a</sup> max.		Specified wall thickness in	Allowable hardness variation <sup>b</sup> HRC
				min.	max.		HRC	HBW		
1	2	3	4	5	6	7	8	9	10	11
1	H40	—	0.5	40	80	60	—	—	—	—
	J55	—	0.5	55	80	75	—	—	—	—
	K55	—	0.5	55	80	95	—	—	—	—
	N80	1	0.5	80	110	100	—	—	—	—
	N80	Q	0.5	80	110	100	—	—	—	—
2	M65	—	0.5	65	85	85	22	235	—	—
	L80	1	0.5	80	95	95	23	241	—	—
	L80	9Cr	0.5	80	95	95	23	241	—	—
	L80	13Cr	0.5	80	95	95	23	241	—	—
	C90	1, 2	0.5	90	105	100	25.4	255	≤ 0.500	3.0
	C90	1, 2	0.5	90	105	100	25.4	255	0.501 to 0.749	4.0
	C90	1, 2	0.5	90	105	100	25.4	255	0.750 to 0.999	5.0
	C90	1, 2	0.5	90	105	100	25.4	255	≥ 1.000	6.0
	C95	—	0.5	95	110	105	—	—	—	—
	T95	1, 2	0.5	95	110	105	25.4	255	≤ 0.500	3.0
	T95	1, 2	0.5	95	110	105	25.4	255	0.501 to 0.749	4.0
	T95	1, 2	0.5	95	110	105	25.4	255	0.750 to 0.999	5.0
	T95	1, 2	0.5	95	110	105	25.4	255	≥ 1.000	6.0
3	P110	—	0.6	110	140	125	—	—	—	—
4	Q125	—	0.65	125	150	135	b	—	≤ 0.500	3.0
	Q125	—	0.65	125	150	135	b	—	0.501 to 0.749	4.0
	Q125	—	0.65	125	150	135	b	—	≥ 0.750	5.0

<sup>a</sup> In case of dispute, laboratory Rockwell C hardness testing shall be used as the referee method.

<sup>b</sup> No hardness limits are specified, but the maximum variation is restricted as a manufacturing control in accordance with 7.8 and 7.9.



Table E.7 — Elongation table

Tensile test specimen				Minimum elongation in 2.0 in							
				%							
				Grade							
				H40	J55	M65	K55 L80	N80-1 N80Q C90	C95 T95	P110	Q125
Specimen area in <sup>2</sup>	Specified wall thickness in			Specified minimum tensile strength ksi							
	Specimen width ¾ in	Specimen width 1 in	Specimen width 1½ in	60	75	85	95	100	105	125	135
1	2	3	4	5	6	7	8	9	10	11	12
0.750	≥ 0.994	≥ 0.746	≥ 0.497	30	24	22	20	19	18	15	14
0.740	0.980-0.993	0.735-0.745	0.490-0.496	29	24	22	19	19	18	15	14
0.730	0.967-0.979	0.726-0.734	0.484-0.489	29	24	21	19	19	18	15	14
0.720	0.954-0.966	0.715-0.725	0.477-0.483	29	24	21	19	19	18	15	14
0.710	0.941-0.953	0.706-0.714	0.471-0.476	29	24	21	19	18	18	15	14
0.700	0.927-0.940	0.695-0.705	0.464-0.470	29	24	21	19	18	18	15	14
0.690	0.914-0.926	0.686-0.694	0.457-0.463	29	24	21	19	18	18	15	14
0.680	0.900-0.913	0.675-0.685	0.450-0.456	29	24	21	19	18	18	15	14
0.670	0.887-0.899	0.666-0.674	0.444-0.449	29	24	21	19	18	17	15	14
0.660	0.874-0.886	0.655-0.665	0.437-0.443	29	24	21	19	18	17	15	14
0.650	0.861-0.873	0.646-0.654	0.431-0.436	29	23	21	19	18	17	15	14
0.640	0.847-0.860	0.635-0.645	0.424-0.430	29	23	21	19	18	17	15	14
0.630	0.834-0.846	0.626-0.634	0.417-0.423	29	23	21	19	18	17	15	14
0.620	0.820-0.833	0.615-0.625	0.410-0.416	28	23	21	19	18	17	15	14
0.610	0.807-0.819	0.606-0.614	0.404-0.409	28	23	21	19	18	17	15	14
0.600	0.794-0.806	0.595-0.605	0.397-0.403	28	23	21	19	18	17	15	14
0.590	0.781-0.793	0.586-0.594	0.391-0.396	28	23	21	19	18	17	15	14
0.580	0.767-0.780	0.575-0.585	0.384-0.390	28	23	21	19	18	17	14	14
0.570	0.754-0.766	0.566-0.574	0.377-0.383	28	23	20	18	18	17	14	13
0.560	0.740-0.753	0.555-0.565	0.370-0.376	28	23	20	18	18	17	14	13
0.550	0.727-0.739	0.546-0.554	0.364-0.369	28	23	20	18	18	17	14	13
0.540	0.714-0.726	0.535-0.545	0.357-0.363	28	23	20	18	17	17	14	13
0.530	0.701-0.713	0.526-0.534	0.351-0.356	28	23	20	18	17	17	14	13
0.520	0.687-0.700	0.515-0.525	0.344-0.350	27	22	20	18	17	17	14	13
0.510	0.674-0.686	0.506-0.514	0.337-0.343	27	22	20	18	17	17	14	13
0.500	0.660-0.673	0.495-0.505	0.330-0.336	27	22	20	18	17	16	14	13
0.490	0.647-0.659	0.486-0.494	0.324-0.329	27	22	20	18	17	16	14	13
0.480	0.634-0.646	0.475-0.485	0.317-0.323	27	22	20	18	17	16	14	13
0.470	0.621-0.633	0.466-0.474	0.311-0.316	27	22	20	18	17	16	14	13
0.460	0.607-0.620	0.455-0.465	0.304-0.310	27	22	20	18	17	16	14	13
0.450	0.594-0.606	0.446-0.454	0.297-0.303	27	22	20	18	17	16	14	13
0.440	0.580-0.593	0.435-0.445	0.290-0.296	27	22	19	18	17	16	14	13
0.430	0.567-0.579	0.426-0.434	0.284-0.289	26	22	19	17	17	16	14	13
0.420	0.554-0.566	0.415-0.425	0.277-0.283	26	22	19	17	17	16	14	13
0.410	0.541-0.553	0.406-0.414	0.271-0.276	26	21	19	17	17	16	14	13
0.400	0.527-0.540	0.395-0.405	0.264-0.270	26	21	19	17	16	16	13	13
0.390	0.514-0.526	0.386-0.394	0.257-0.263	26	21	19	17	16	16	13	12
0.380	0.500-0.513	0.375-0.385	0.250-0.256	26	21	19	17	16	16	13	12
0.370	0.487-0.499	0.366-0.374	0.244-0.249	26	21	19	17	16	16	13	12
0.360	0.474-0.486	0.355-0.365	0.237-0.243	26	21	19	17	16	15	13	12
0.350	0.461-0.473	0.346-0.354	0.231-0.236	25	21	19	17	16	15	13	12
0.340	0.447-0.460	0.335-0.345	0.224-0.230	25	21	18	17	16	15	13	12
0.330	0.434-0.446	0.326-0.334	0.217-0.223	25	21	18	17	16	15	13	12
0.320	0.420-0.433	0.315-0.325	0.210-0.216	25	20	18	16	16	15	13	12
0.310	0.407-0.419	0.306-0.314	0.204-0.209	25	20	18	16	16	15	13	12
0.300	0.394-0.406	0.295-0.305	0.197-0.203	25	20	18	16	16	15	13	12

Table E.7 (continued)

Tensile test specimen				Minimum elongation in 2.0 in							
				%							
				Grade							
				H40	J55	M65	K55 L80	N80-1 N80Q C90	C95 T95	P110	Q125
Specimen area in <sup>2</sup>	Specified wall thickness in			Specified minimum tensile strength ksi							
	Specimen width ¾ in	Specimen width 1 in	Specimen width 1½ in	60	75	85	95	100	105	125	135
1	2	3	4	5	6	7	8	9	10	11	12
0.290	0.381-0.393	0.286-0.294	0.191-0.196	24	20	18	16	15	15	13	12
0.280	0.367-0.380	0.275-0.285	0.184-0.190	24	20	18	16	15	15	13	12
0.270	0.354-0.366	0.266-0.274	0.177-0.183	24	20	18	16	15	15	12	12
0.260	0.340-0.353	0.255-0.265	0.170-0.176	24	20	17	16	15	14	12	12
0.250	0.327-0.339	0.246-0.254	0.164-0.169	24	19	17	16	15	14	12	11
0.240	0.314-0.326	0.235-0.245	0.157-0.163	24	19	17	16	15	14	12	11
0.230	0.301-0.313	0.226-0.234	0.151-0.156	23	19	17	15	15	14	12	11
0.220	0.287-0.300	0.215-0.225	0.144-0.150	23	19	17	15	15	14	12	11
0.210	0.274-0.286	0.206-0.214	0.137-0.143	23	19	17	15	14	14	12	11
0.200	0.260-0.273	0.195-0.205	0.130-0.136	23	19	17	15	14	14	12	11
0.190	0.247-0.259	0.186-0.194	0.124-0.129	22	18	16	15	14	14	12	11
0.180	0.234-0.246	0.175-0.185	0.117-0.123	22	18	16	15	14	13	11	11
0.170	0.221-0.233	0.166-0.174	0.111-0.116	22	18	16	15	14	13	11	11
0.160	0.207-0.220	0.155-0.165	0.104-0.110	22	18	16	14	14	13	11	10
0.150	0.194-0.206	0.146-0.154	0.097-0.103	21	18	16	14	14	13	11	10
0.140	0.180-0.193	0.135-0.145	0.090-0.096	21	17	15	14	13	13	11	10
0.130	0.167-0.179	0.126-0.134	0.084-0.089	21	17	15	14	13	13	11	10
0.120	0.154-0.166	0.115-0.125	0.077-0.083	20	17	15	14	13	12	11	10
0.110	0.141-0.153	0.106-0.114	0.071-0.076	20	16	15	13	13	12	10	9.5
0.100	0.127-0.140	0.095-0.105	0.064-0.070	20	16	14	13	12	12	10	9.5
0.090	0.114-0.126	0.086-0.094	0.057-0.063	19	16	14	13	12	12	10	9.5
0.080	0.100-0.113	0.075-0.085	0.050-0.056	19	15	14	12	12	11	10	9

**Table E.8 — Critical thickness for couplings with API threads**

Dimensions in inches

Label 1	Critical thickness for couplings						
	NU	EU	Special-clearance		BC	LC	STC
			EU	BC			
1	2	3	4	5	6	7	8
1.050	0.169	0.211	—	—	—	—	—
1.315	0.211	0.258	—	—	—	—	—
1.660	0.239	0.240	—	—	—	—	—
1.900	0.196	0.251	—	—	—	—	—
2-3/8	0.304	0.300	0.224	—	—	—	—
2-7/8	0.380	0.358	0.254	—	—	—	—
3-1/2	0.451	0.454	0.294	—	—	—	—
4	0.454	0.458	—	—	—	—	—
4-1/2	0.435	0.493	—	0.259	0.322	0.349	0.337
5	—	—	—	0.266	0.360	0.392	0.372
5-1/2	—	—	—	0.268	0.356	0.389	0.370
6-5/8	—	—	—	0.274	0.469	0.508	0.485
7	—	—	—	0.280	0.420	0.458	0.430
7-5/8	—	—	—	0.348	0.536	0.573	0.546
8-5/8	—	—	—	0.352	0.602	0.647	0.612
9-5/8	—	—	—	0.352	0.602	0.657	0.614
10-3/4	—	—	—	0.352	0.602	—	0.618
11-3/4	—	—	—	—	0.602	—	0.618
13-3/8	—	—	—	—	0.602	—	0.618
16	—	—	—	—	0.667	—	0.632
18-5/8	—	—	—	—	0.854	—	0.819
20	—	—	—	—	0.667	0.673	0.634

NOTE The coupling blank thickness is greater than indicated above, due to thread height and manufacturing allowance to avoid black crest threads.

**Table E.9 — Acceptable size impact specimens and absorbed energy reduction factor**

Test specimen size	Specimen dimensions mm	Reduction factor
Full size	10.0 × 10.0	1.00
¾-size	10.0 × 7.5	0.80
½-size	10.0 × 5.0	0.55

**Table E.10 — Hierarchy of test specimen orientation and size**

Choice	Orientation	Size
1 <sup>st</sup>	Transverse	Full size
2 <sup>nd</sup>	Transverse	¾-size
3 <sup>rd</sup>	Transverse	½-size
4 <sup>th</sup>	Longitudinal	Full size
5 <sup>th</sup>	Longitudinal	¾-size
6 <sup>th</sup>	Longitudinal	½-size

**Table E.11 — Charpy impact test specimen requirements for couplings Grades J55 and K55**

Label 1	API connection type and CVN specimen orientation, size, energy and temperature reduction						
	NU	EU	Special-clearance <sup>b</sup>		BC	LC	STC
			EU	BC			
1	2	3	4	5	6	7	8
1.050	a	L-5-11-A	—	—	—	—	—
1.315	L-5-11 A	L-7-16-A	—	—	—	—	—
1.660	L-5-11-B	L-5-11-B	—	—	—	—	—
1.900	L-5-11-A	L-7-16-B	—	—	—	—	—
2-3/8	L-7-16-A	L-7-16-A	L-7-16-A	—	—	—	—
2-7/8	L-10-20-A	L-10-20-A	L-10-20-A	—	—	—	—
3-1/2	T-5-8-E	T-5-8-E	T-5-8-D	—	—	—	—
4	T-7-12-B	T-7-12-B	—	L-7-16-A	—	—	—
4-1/2	T-7-12-B	T-7-12-B	—	T-5-8-C	L-7-16-A	L-10-20-A	L-10-20-A
5	—	—	—	T-5-8-C	T-5-8-D	T-5-8-D	T-5-8-D
5-1/2	—	—	—	T-10-15-A	T-5-8-D	T-5-8-D	T-5-8-D
6-5/8	—	—	—	T-7-12-A	T-10-15-A	T-10-15-A	T-10-15-A
7	—	—	—	T-10-15-A	T-7-12-A	T-10-15-A	T-7-12-B
7-5/8	—	—	—	T-10-15-A	T-10-15-A	T-10-15-A	T-10-15-A
8-5/8	—	—	—	T-10-15-A	T-10-15-A	T-10-15-A	T-10-15-A
9-5/8	—	—	—	T-10-15-A	T-10-15-A	T-10-15-A	T-10-15-A
10-3/4	—	—	—	—	T-10-15-A	—	T-10-15-A
11-3/4	—	—	—	—	T-10-15-A	—	T-10-15-A
13-3/8	—	—	—	—	T-10-15-A	—	T-10-15-A
16	—	—	—	—	T-10-15-A	—	T-10-15-A
18-5/8	—	—	—	—	T-10-15-A	—	T-10-15-A
20	—	—	—	—	T-10-15-A	T-10-15-A	T-10-15-A

NOTE: In this table, the specimen orientation (T or L) is followed by the minimum specimen size (10, 7 or 5) which is followed by the minimum absorbed energy requirement (foot pounds) and the temperature reduction (A, B, C, D or E), according to the following code. Both the absorbed energy requirement and the test temperature reduction requirement are adjusted for the test specimen size indicated.

- T is the transverse specimen orientation (see Figure D.12)
- L is the longitudinal specimen orientation (see Figure D.12)
- 10 = full size (i.e. 10 mm × 10 mm)
- 7 = ¾-size (i.e. 10 mm × 7.5 mm)
- 5 = ½-size (i.e. 10 mm × 5 mm)
- A = no temperature reduction
- B = 5 °F reduction
- C = 10 °F reduction
- D = 15 °F reduction
- E = 20 °F reduction

<sup>a</sup> Not thick enough to test.  
<sup>b</sup> The above assumes that special-clearance couplings are machined from standard couplings.

**Table E.12 — Charpy impact test specimen requirements for couplings Grade L80 all types**

Label 1	API connection type and CVN specimen orientation, size and energy						
	NU	EU	Special-clearance <sup>b</sup>		BC	LC	STC
			EU	BC			
1	2	3	4	5	6	7	8
1.050	a	L-5-16	—	—	—	—	—
1.315	L-5-16	L-7-24	—	—	—	—	—
1.660	L-5-16	L-5-16	—	—	—	—	—
1.900	L-5-16	L-7-24	—	—	—	—	—
2-3/8	L-7-24	L-7-24	L-7-24	—	—	—	—
2-7/8	L-10-30	L-10-30	L-10-30	—	—	—	—
3-1/2	T-5-8	T-5-8	T-5-8	—	—	—	—
4	T-7-12	T-7-12	—	—	—	—	—
4-1/2	T-7-12	T-7-12	—	L-7-24	L-7-24	L-10-30	—
5	—	—	—	T-5-8	T-5-8	T-5-8	—
5-1/2	—	—	—	T-5-8	T-5-8	T-5-8	—
6-5/8	—	—	—	T-10-15	T-10-15	T-10-15	—
7	—	—	—	T-7-12	T-7-12	T-10-15	—
7-5/8	—	—	—	T-10-15	T-10-15	T-10-15	—
8-5/8	—	—	—	T-10-15	T-10-15	T-10-15	—
9-5/8	—	—	—	T-10-15	T-10-15	T-10-16	—
10-3/4	—	—	—	T-10-15	T-10-15	—	T-10-15
11-3/4	—	—	—	—	T-10-15	—	T-10-15
13-3/8	—	—	—	—	T-10-15	—	T-10-15
16	—	—	—	—	T-10-16	—	T-10-15
18-5/8	—	—	—	—	T-10-18	—	T-10-18
20	—	—	—	—	T-10-16	T-10-16	T-10-15

NOTE In this table, the specimen orientation (T or L) is followed by the minimum specimen size (10, 7 or 5) which is followed by the minimum absorbed energy requirement (foot pounds) according to the following code. The absorbed energy requirement is adjusted for the test specimen size indicated.

T is the transverse specimen orientation (see Figure D.12)  
L is the longitudinal specimen orientation (see Figure D.12)  
10 = full size (i.e. 10 mm × 10 mm)  
7 = ¾-size (i.e. 10 mm × 7.5 mm)  
5 = ½-size (i.e. 10 mm × 5 mm)

<sup>a</sup> Not thick enough to test.  
<sup>b</sup> The above assumes that special-clearance couplings are machined from standard couplings.

**Table E.13 — Charpy impact test specimen requirements for couplings Grade C90**

Label 1	API connection type and CVN specimen orientation, size and energy						STC
	NU	EU	Special-clearance <sup>b</sup>		BC	LC	
			EU	BC			
1	2	3	4	5	6	7	8
1.050	a	L-5-16	—	—	—	—	—
1.315	L-5-16	L-7-24	—	—	—	—	—
1.660	L-5-16	L-5-16	—	—	—	—	—
1.900	L-5-16	L-7-24	—	—	—	—	—
2-3/8	L-7-24	L-7-24	L-7-24	—	—	—	—
2-7/8	L-10-30	L-10-30	L-10-30	—	—	—	—
3-1/2	T-5-8	T-5-8	T-5-8	—	—	—	—
4	T-7-12	T-7-12	—	—	—	—	—
4-1/2	T-7-12	T-7-12	—	L-7-24	L-7-24	L-10-30	—
5	—	—	—	T-5-8	T-5-8	T-5-8	—
5-1/2	—	—	—	T-5-8	T-5-8	T-5-8	—
6-5/8	—	—	—	T-10-15	T-10-15	T-10-15	—
7	—	—	—	T-7-12	T-7-12	T-10-15	—
7-5/8	—	—	—	T-10-15	T-10-15	T-10-16	—
8-5/8	—	—	—	T-10-15	T-10-16	T-10-17	—
9-5/8	—	—	—	T-10-15	T-10-16	T-10-17	—
10-3/4	—	—	—	T-10-15	T-10-16	—	T-10-17
11-3/4	—	—	—	—	T-10-16	—	T-10-17
13-3/8	—	—	—	—	T-10-16	—	T-10-17
16	—	—	—	—	—	—	—
18-5/8	—	—	—	—	—	—	—
20	—	—	—	—	—	—	—

NOTE In this table, the specimen orientation (T or L) is followed by the minimum specimen size (10, 7 or 5) which is followed by the minimum absorbed energy requirement (foot pounds) according to the following code. The absorbed energy requirement is adjusted for the test specimen size indicated.

- T is the transverse specimen orientation (see Figure D.12)
- L is the longitudinal specimen orientation (see Figure D.12)
- 10 = full size (i.e. 10 mm × 10 mm)
- 7 = ¾-size (i.e. 10 mm × 7.5 mm)
- 5 = ½-size (i.e. 10 mm × 5 mm)

<sup>a</sup> Not thick enough to test.

<sup>b</sup> The above assumes that special-clearance couplings are machined from standard couplings.

**Table E.14 — Charpy impact test specimen requirements for couplings —  
Grades N80 Type 1, N80Q, C95 and T95**

Label 1	API connection type and CVN specimen orientation, size and energy						
	NU	EU	Special-clearance <sup>b</sup>		BC	LC	STC
			EU	BC			
1	2	3	4	5	6	7	8
1.050	a	L-5-16	—	—	—	—	—
1.315	L-5-16	L-7-24	—	—	—	—	—
1.660	L-5-16	L-5-16	—	—	—	—	—
1.900	L-5-16	L-7-24	—	—	—	—	—
2-3/8	L-7-24	L-7-24	L-7-24	—	—	—	—
2-7/8	L-10-30	L-10-30	L-10-30	—	—	—	—
3-1/2	T-5-8	T-5-8	T-5-8	—	—	—	—
4	T-7-12	T-7-12	—	—	—	—	—
4-1/2	T-7-12	T-10-15	—	L-7-24	L-7-24	L-10-30	—
5	—	—	—	T-5-8	T-5-8	T-5-8	—
5-1/2	—	—	—	T-5-8	T-5-8	T-5-8	—
6-5/8	—	—	—	T-10-15	T-10-15	T-10-16	—
7	—	—	—	T-7-12	T-7-12	T-10-15	—
7-5/8	—	—	—	T-10-15	T-10-16	T-10-17	—
8-5/8	—	—	—	T-10-15	T-10-17	T-10-18	—
9-5/8	—	—	—	T-10-15	T-10-17	T-10-18	—
10-3/4	—	—	—	T-10-15	T-10-17	—	T-10-17
11-3/4	—	—	—	—	T-10-17	—	T-10-17
13-3/8	—	—	—	—	T-10-17	—	T-10-17
16	—	—	—	—	—	—	—
18-5/8	—	—	—	—	—	—	—
20	—	—	—	—	—	—	—

NOTE In this table, the specimen orientation (T or L) is followed by the minimum specimen size (10, 7 or 5) which is followed by the minimum absorbed energy requirement (foot pounds) according to the following code. The absorbed energy requirement is adjusted for the test specimen size indicated.

T is the transverse specimen orientation (see Figure D.12)  
L is the longitudinal specimen orientation (see Figure D.12)  
10 = full size (i.e. 10 mm × 10 mm)  
7 = ¾-size (i.e. 10 mm × 7.5 mm)  
5 = ½-size (i.e. 10 mm × 5 mm)

<sup>a</sup> Not thick enough to test.  
<sup>b</sup> The above assumes that special-clearance couplings are machined from standard couplings.

**Table E.15 — Charpy impact test specimen requirements for couplings Grade P110**

Label 1	API connection type and CVN specimen orientation, size and energy						
	NU	EU	Special-clearance <sup>b</sup>		BC	LC	STC
			EU	BC			
1	2	3	4	5	6	7	8
1.050	a	L-5-16	—	—	—	—	—
1.315	L-5-16	L-7-24	—	—	—	—	—
1.660	L-5-16	L-5-16	—	—	—	—	—
1.900	L-5-16	L-7-24	—	—	—	—	—
2-3/8	L-7-25	L-7-25	L-7-24	—	—	—	—
2-7/8	L-10-34	L-10-33	L-10-30	—	—	—	—
3-1/2	T-5-10	T-5-10	T-5-8	—	—	—	—
4	T-7-15	T-7-15	—	—	—	—	—
4-1/2	T-7-14	T-7-15	—	L-7-24	L-7-26	L-10-33	—
5	—	—	—	T-5-8	T-5-9	T-5-9	—
5-1/2	—	—	—	T-5-8	T-5-9	T-5-9	—
6-5/8	—	—	—	T-10-15	T-10-19	T-10-20	—
7	—	—	—	T-7-12	T-7-14	T-10-19	—
7-5/8	—	—	—	T-10-16	T-10-20	T-10-21	—
8-5/8	—	—	—	T-10-16	T-10-22	T-10-23	—
9-5/8	—	—	—	T-10-16	T-10-22	T-10-23	—
10-3/4	—	—	—	T-10-16	T-10-22	—	T-10-22
11-3/4	—	—	—	—	T-10-22	—	T-10-22
13-3/8	—	—	—	—	T-10-22	—	T-10-22
16	—	—	—	—	—	—	—
18-5/8	—	—	—	—	—	—	—
20	—	—	—	—	—	—	—

NOTE In this table, the specimen orientation (T or L) is followed by the minimum specimen size (10, 7 or 5) which is followed by the minimum absorbed energy requirement (foot pounds) according to the following code. The absorbed energy requirement is adjusted for the test specimen size indicated.

- T is the transverse specimen orientation (see Figure D.12)
- L is the longitudinal specimen orientation (see Figure D.12)
- 10 = full size (i.e. 10 mm × 10 mm)
- 7 = ¾-size (i.e. 10 mm × 7.5 mm)
- 5 = ½-size (i.e. 10 mm × 5 mm)

<sup>a</sup> Not thick enough to test.  
<sup>b</sup> The above assumes that special-clearance couplings are machined from standard couplings.



**Table E.16 — Charpy impact test specimen requirements for couplings Grade Q125**

Label 1	API connection type and CVN specimen orientation, size and energy			
	Special-clearance <sup>a</sup>	BC	LC	STC
	BC			
1	2	3	4	5
4-1/2	L-7-25	L-7-27	L-10-35	—
5	T-5-9	T-5-10	T-5-10	—
5-1/2	T-5-9	T-5-10	T-5-10	—
6-5/8	T-10-16	T-10-20	T-10-21	—
7	T-7-13	T-7-15	T-10-19	—
7-5/8	T-10-18	T-10-22	T-10-23	—
8-5/8	T-10-18	T-10-23	T-10-24	—
9-5/8	T-10-18	T-10-23	T-10-25	—
10-3/4	T-10-18	T-10-23	—	T-10-24
11-3/4	—	T-10-23	—	T-10-24
13-3/8	—	T-10-23	—	T-10-24
16	—	—	—	—
18-5/8	—	—	—	—
20	—	—	—	—

**NOTE** In this table, the specimen orientation (T or L) is followed by the minimum specimen size (10, 7 or 5) which is followed by the minimum absorbed energy requirement (foot pounds) according to the following code. The absorbed energy requirement is adjusted for the test specimen size indicated.

- T is the transverse specimen orientation (see Figure D.12)
- L is the longitudinal specimen orientation (see Figure D.12)
- 10 = full size (i.e. 10 mm × 10 mm)
- 7 = ¾-size (i.e. 10 mm × 7.5 mm)
- 5 = ½-size (i.e. 10 mm × 5 mm)

<sup>a</sup> The above assumes that special-clearance couplings are machined from standard couplings.

**Table E.17 — Transverse Charpy absorbed energy requirements for couplings**

Maximum critical thickness for various grades in					Minimum transverse absorbed energy ft-lb
L80	C90	N80Q, C95, T95	P110	Q125	
1	2	3	4	5	6
0.652	0.550	0.505	0.307	0.258	15
0.721	0.612	0.565	0.354	0.302	16
0.790	0.675	0.625	0.401	0.346	17
0.860	0.738	0.685	0.448	0.390	18
0.929	0.800	0.745	0.495	0.434	19
0.998	0.863	0.805	0.542	0.478	20
1.067	0.926	0.864	0.589	0.521	21
	0.988	0.924	0.636	0.565	22
	1.051	0.984	0.683	0.609	23
		1.044	0.730	0.653	24
			0.777	0.697	25
			0.824	0.741	26
			0.871	0.785	27
			0.918	0.828	28
			0.965	0.872	29
			1.012	0.916	30
				0.960	31
				1.004	32

For critical thickness greater than shown above, the requirements shall be according to the equations for the wall thickness and grade.

NOTE 1 Critical thicknesses greater than shown in Table E.8 are not applicable for couplings with API threads and are shown here for information for special applications.

NOTE 2 Grade M65 is not mentioned in this table, because it is furnished with L80 Type 1 couplings.

**Table E.18 — Longitudinal Charpy absorbed energy requirements for couplings**

Maximum critical thickness in					Minimum longitudinal absorbed energy ft-lb
L80	C90	N80Q, C95, T95	P110	Q125	
1	2	3	4	5	6
0.635	0.534	0.491	0.295	0.247	30
0.669	0.565	0.520	0.319	0.269	31
0.704	0.597	0.550	0.342	0.291	32
0.738	0.628	0.580	0.366	0.313	33
0.773	0.659	0.610	0.389	0.335	34
0.808	0.691	0.640	0.413	0.357	35
0.842	0.722	0.670	0.436	0.379	36
0.877	0.753	0.700	0.460	0.401	37
0.912	0.785	0.730	0.483	0.423	38
0.946	0.816	0.760	0.507	0.445	39
0.981	0.847	0.790	0.530	0.467	40
1.015	0.879	0.819	0.554	0.489	41
	0.910	0.849	0.577	0.510	42
	0.941	0.879	0.601	0.532	43
	0.973	0.909	0.624	0.554	44
	1.004	0.939	0.648	0.576	45
		0.969	0.671	0.598	46
		0.999	0.695	0.620	47
		1.029	0.718	0.642	48
			0.742	0.664	49
			0.765	0.686	50

For critical thickness greater than shown above, the requirements shall be according to the equations for the wall thickness and grade.

NOTE 1 Critical thicknesses greater than shown in Table E.8 are not applicable for couplings with API threads and are shown here for information for special applications.

NOTE 2 Grade M65 is not mentioned in this table, because it is furnished with L80 Type 1 couplings.

**Table E.19 — Transverse Charpy absorbed energy requirements for pipe**

Maximum specified wall thickness in					Minimum transverse absorbed energy ft-lb
N80Q, L80	C90	C95, T95	P110	Q125	
1	2	3	4	5	6
0.442	0.346	0.306			10
0.524	0.419	0.375			11
0.606	0.492	0.444			12
0.689	0.565	0.513			13
0.771	0.638	0.583			14
0.853	0.711	0.652	0.505	0.258	15
0.935	0.785	0.721	0.565	0.302	16
1.018	0.858	0.790	0.625	0.346	17
	0.931	0.860	0.685	0.390	18
	1.004	0.929	0.745	0.434	19
		0.998	0.805	0.478	20
			0.864	0.521	21
			0.924	0.565	22
			0.984	0.609	23
			1.044	0.653	24
				0.697	25
				0.741	26
				0.785	27
				0.828	28
				0.872	29
				0.916	30
				0.960	31
				1.004	32

For wall thickness greater than shown above, the requirements shall be according to the equations for the wall thickness and grade.

NOTE Wall thicknesses greater than those of standard ISO/API pipe are shown here for information for special applications.

**Table E.20 — Longitudinal Charpy absorbed energy requirements for pipe**

Maximum specified wall thickness in					Minimum longitudinal absorbed energy ft·lb
N80Q, L80	C90	C95, T95	P110	Q125	
1	2	3	4	5	6
0.421	0.328	0.288	—	—	20
0.462	0.364	0.323	—	—	21
0.504	0.401	0.358	—	—	22
0.545	0.437	0.392	—	—	23
0.586	0.474	0.427	—	—	24
0.627	0.510	0.461	—	—	25
0.668	0.547	0.496	—	—	26
0.709	0.584	0.531	—	—	27
0.750	0.620	0.565	—	—	28
0.791	0.657	0.600	—	—	29
0.833	0.693	0.635	0.491	0.247	30
0.874	0.730	0.669	0.520	0.269	31
0.915	0.766	0.704	0.550	0.291	32
0.956	0.803	0.738	0.580	0.313	33
0.997	0.839	0.773	0.610	0.335	34
1.038	0.876	0.808	0.640	0.357	35
	0.913	0.842	0.670	0.379	36
	0.949	0.877	0.700	0.401	37
	0.986	0.912	0.730	0.423	38
	1.022	0.946	0.760	0.445	39
		0.981	0.790	0.467	40
		1.015	0.819	0.489	41
			0.849	0.510	42
			0.879	0.532	43
			0.909	0.554	44
			0.939	0.576	45
			0.969	0.598	46
			0.999	0.620	47
			1.029	0.642	48
				0.664	49
				0.686	50

For wall thicknesses greater than shown above, the requirements shall be according to the equations for the wall thickness and grade.

NOTE Wall thicknesses greater than those of standard ISO/API pipe are shown here for information for special applications.

**Table E.21 — Transverse impact specimen size required for pipe in quenched and tempered grades**

Label 1	Calculated wall thickness required to machine transverse Charpy impact specimens		
	in		
	Full size	¾-size	½-size
1	2	3	4
3-1/2	0.809	0.711	0.612
4	0.752	0.654	0.555
4-1/2	0.712	0.614	0.515
5	0.681	0.583	0.484
5-1/2	0.656	0.558	0.459
6-5/8	0.616	0.518	0.419
7	0.606	0.508	0.409
7-5/8	0.591	0.493	0.394
7-3/4	0.588	0.490	0.391
8-5/8	0.572	0.474	0.375
9-5/8	0.557	0.459	0.360
10-3/4	0.544	0.446	0.347
11-3/4	0.535	0.437	0.338
13-3/8	0.522	0.424	0.325
16	0.508	0.410	0.311
18-5/8	0.497	0.399	0.300
20	0.493	0.395	0.296

NOTE The wall thicknesses in columns 2, 3 and 4 that are in excess of the maximum wall thicknesses for ISO/API pipe are for information only. The above provides a 0.020 in ID and a 0.020 in OD machining allowance.

**Table E.22 — Longitudinal impact specimen size required for pipe in quenched and tempered grades**

Label 1	Calculated wall thickness required to machine longitudinal Charpy impact specimens		
	in		
	Full size	¾-size	½-size
1	2	3	4
1.050	0.472	0.374	0.275
1.315	0.464	0.366	0.267
1.660	0.458	0.360	0.261
1.900	0.455	0.357	0.258
2.063	0.453	0.355	0.256
2-3/8	0.450	0.352	0.253
2-7/8	0.448	0.350	0.251
3-1/2	0.445	0.347	0.248
4	0.444	0.346	0.247
4-1/2	0.443	0.345	0.246
5	0.442	0.344	0.245
5-1/2	0.441	0.343	0.244
6-5/8	0.440	0.342	0.243
7	0.440	0.342	0.243
7-5/8	0.439	0.341	0.242
7-3/4	0.439	0.341	0.242
8-5/8	0.439	0.341	0.242
9-5/8	0.438	0.340	0.241
10-3/4	0.438	0.340	0.241
11-3/4	0.437	0.339	0.240
13-3/8	0.437	0.339	0.240
16	0.436	0.338	0.239
18-5/8	0.436	0.338	0.239
20	0.436	0.338	0.239

NOTE The wall thicknesses in columns 2, 3 and 4 that are in excess of the maximum wall thicknesses for ISO/API pipe are for information only. The above provides a 0.020 in ID and a 0.020 in OD machining allowance.

**Table E.23 — Distance between plates for electric weld flattening tests**

Grade	$D/t$ ratio	Maximum distance between plates in
1	2	3
H40	$\geq 16$ $< 16$	$0.5 \times D$ $D \times (0.830 - 0.020 6 D/t)$
J55 & K55	$\geq 16$ 3.93 to 16 $< 3.93$	$0.65 \times D$ $D \times (0.980 - 0.020 6 D/t)$ $D \times (1.104 - 0.051 8 D/t)$
M65	All	$D \times (1.074 - 0.019 4 D/t)$
N80 Type 1, N80Q <sup>a</sup>	9 to 28	$D \times (1.074 - 0.019 4 D/t)$
L80 Type 1	9 to 28	$D \times (1.074 - 0.019 4 D/t)$
C95 <sup>a</sup>	9 to 28	$D \times (1.080 - 0.017 8 D/t)$
P110 <sup>b</sup>	All	$D \times (1.086 - 0.016 3 D/t)$
Q125 <sup>b</sup>	All	$D \times (1.092 - 0.014 0 D/t)$

$D$  is the specified outside diameter of pipe, in inches.  
 $t$  is the specified wall thickness of the pipe, in inches.  
<sup>a</sup> If the flattening test fails at 12 o'clock or 6 o'clock, the flattening shall continue until the remaining portion of the specimen fails at the 3 o'clock or 9 o'clock position. Premature failure at 12 o'clock or 6 o'clock shall not be considered basis for rejection.  
<sup>b</sup> See A.5 (SR11). Flattening shall be at least  $0.85 \times D$ .

**Table E.24 — Dimensions and masses for standard casing and for casing threaded with API round thread, buttress thread and extreme-line connections**

Labels <sup>a</sup>		Outside diameter	Nominal linear mass T&C <sup>b, c</sup>	Wall thickness	Inside diameter	Drift diameter	Plain end	Calculated mass <sup>c</sup>					
								$e_m$ , mass gain or loss due to end finishing <sup>d</sup>					
		<i>D</i> in	lb/ft	<i>t</i> in	<i>d</i> in	in	$w_{pe}$ lb/ft	lb					
								Round thread		Buttress thread		Extreme-line	
1	2							Short	Long	Reg. OD	SCC	Standard	Optional
1	2	3	4	5	6	7	8	9	10	11	12	13	14
4-1/2	9.50	4.500	9.50	0.205	4.090	3.965	9.41	4.20	—	—	—	—	—
4-1/2	10.50	4.500	10.50	0.224	4.052	3.927	10.24	3.80	—	5.00	2.56	—	—
4-1/2	11.60	4.500	11.60	0.250	4.000	3.875	11.36	3.40	3.80	4.60	2.16	—	—
4-1/2	13.50	4.500	13.50	0.290	3.920	3.795	13.05	—	3.20	4.00	1.56	—	—
4-1/2	15.10	4.500	15.10	0.337	3.826	3.701	15.00	—	2.80	3.20	0.76	—	—
5	11.50	5.000	11.50	0.220	4.560	4.435	11.24	5.40	—	—	—	—	—
5	13.00	5.000	13.00	0.253	4.494	4.369	12.84	4.80	5.80	6.60	2.42	—	—
5	15.00	5.000	15.00	0.296	4.408	4.283	14.88	4.20	5.20	5.80	1.62	4.60	—
5	18.00	5.000	18.00	0.362	4.276	4.151	17.95	—	4.20	4.40	0.22	1.40	—
5	21.40	5.000	21.40	0.437	4.126	4.001	21.32	—	2.95	2.46	-1.72	—	—
5	23.20	5.000	23.20	0.478	4.044	3.919	23.11	—	2.30	2.05	-2.09	—	—
5	24.10	5.000	24.10	0.500	4.000	3.875	24.05	—	1.95	1.24	-2.94	—	—
5-1/2	14.00	5.500	14.00	0.244	5.012	4.887	13.71	5.40	—	—	—	—	—
5-1/2	15.50	5.500	15.50	0.275	4.950	4.825	15.36	4.80	5.80	6.40	2.10	5.80	4.20
5-1/2	17.00	5.500	17.00	0.304	4.892	4.767	16.89	4.40	5.40	5.80	1.50	4.80	3.20
5-1/2	20.00	5.500	20.00	0.361	4.778	4.653	19.83	—	4.40	4.60	0.30	1.40	-0.20
5-1/2	23.00	5.500	23.00	0.415	4.670	4.545	22.56	—	3.20	3.40	-0.90	0.00	-1.60
5-1/2	26.80	5.500	26.80	0.500	4.500	4.375	26.72	—	—	—	—	—	—
5-1/2	29.70	5.500	29.70	0.562	4.376	4.251	29.67	—	—	—	—	—	—
5-1/2	32.60	5.500	32.60	0.625	4.250	4.125	32.57	—	—	—	—	—	—
5-1/2	35.30	5.500	35.30	0.687	4.126	4.001	35.35	—	—	—	—	—	—
5-1/2	38.00	5.500	38.00	0.750	4.000	3.875	38.08	—	—	—	—	—	—
5-1/2	40.50	5.500	40.50	0.812	3.876	3.751	40.69	—	—	—	—	—	—
5-1/2	43.10	5.500	43.10	0.875	3.750	3.625	43.26	—	—	—	—	—	—
6-5/8	20.00	6.625	20.00	0.288	6.049	5.924	19.51	11.00	13.60	14.40	2.38	—	—
6-5/8	24.00	6.625	24.00	0.352	5.921	5.796	23.60	9.60	12.00	12.60	0.58	3.40	1.80
6-5/8	28.00	6.625	28.00	0.417	5.791	5.666	27.67	—	10.20	10.60	-1.42	0.20	-1.40
6-5/8	32.00	6.625	32.00	0.475	5.675	5.550	31.23	—	8.80	9.00	-3.02	-1.40	-3.00
7	17.00	7.000	17.00	0.231	6.538	6.413	16.72	10.00	—	—	—	—	—
7	20.00	7.000	20.00	0.272	6.456	6.331	19.56	9.40	—	—	—	—	—
7	23.00	7.000	23.00	0.317	6.366	6.250 <sup>e</sup>	22.65	8.00	10.40	11.00	1.60	6.00	4.20
7	23.00	7.000	23.00	0.317	6.366	6.241	22.65	8.00	10.40	11.00	1.60	6.00	4.20
7	26.00	7.000	26.00	0.362	6.276	6.151	25.69	7.20	9.40	9.60	0.20	2.80	1.00
7	29.00	7.000	29.00	0.408	6.184	6.059	28.75	—	8.00	8.20	-1.20	0.60	-1.20
7	32.00	7.000	32.00	0.453	6.094	6.000 <sup>e</sup>	31.70	—	6.60	6.80	-2.60	-0.60	-2.40
7	32.00	7.000	32.00	0.453	6.094	5.969	31.70	—	6.60	6.80	-2.60	-0.60	-2.40
7	35.00	7.000	35.00	0.498	6.004	5.879	34.61	—	5.60	5.60	-3.80	1.00	-1.80
7	38.00	7.000	38.00	0.540	5.920	5.795	37.29	—	4.40	4.20	-5.20	-0.20	-3.00
7	42.70	7.000	42.70	0.625	5.750	5.625	42.59	—	—	—	—	—	—
7	46.40	7.000	46.40	0.687	5.625	5.500	46.36	—	—	—	—	—	—
7	50.10	7.000	50.10	0.750	5.500	5.375	50.11	—	—	—	—	—	—
7	53.60	7.000	53.60	0.812	5.376	5.251	53.71	—	—	—	—	—	—
7	57.10	7.000	57.10	0.875	5.250	5.125	57.29	—	—	—	—	—	—

See notes at end of table.



Table E.24 (continued)

Labels <sup>a</sup>		Outside diameter	Nominal linear mass T&C <sup>b, c</sup>	Wall thickness	Inside diameter	Drift diameter	Calculated mass <sup>c</sup>						
							Plain end	$e_m$ , mass gain or loss due to end finishing <sup>d</sup>					
1	2	D in	lb/ft	t in	d in	in		$w_{pe}$ lb/ft	Round thread		Buttress thread		Extreme-line
							Short		Long	Reg. OD	SCC	Standard	Optional
1	2	3	4	5	6	7	8	9	10	11	12	13	14
7-5/8	24.00	7.625	24.00	0.300	7.025	6.900	23.49	15.80	—	—	—	—	—
7-5/8	26.20	7.625	26.40	0.328	6.969	6.844	25.59	15.20	19.00	20.60	6.21	6.40	4.00
7-5/8	29.70	7.625	29.70	0.375	6.875	6.750	29.06	—	17.40	18.80	4.41	2.60	0.20
7-5/8	33.70	7.625	33.70	0.430	6.765	6.640	33.07	—	15.80	17.00	2.61	0.00	-2.40
7-5/8	39.00	7.625	39.00	0.500	6.625	6.500	38.08	—	13.60	14.60	0.21	-2.20	-4.60
7-5/8	42.80	7.625	42.80	0.562	6.501	6.376	42.43	—	12.01	11.39	-3.01	—	—
7-5/8	45.30	7.625	45.30	0.595	6.435	6.310	44.71	—	11.04	11.04	-3.36	—	—
7-5/8	47.10	7.625	47.10	0.625	6.375	6.250	46.77	—	10.16	9.23	-5.17	—	—
7-5/8	51.20	7.625	51.20	0.687	6.251	6.126	50.95	—	—	—	—	—	—
7-5/8	55.30	7.625	55.30	0.750	6.125	6.000	55.12	—	—	—	—	—	—
7-3/4	46.10	7.750	46.10	0.595	6.560	6.500 <sup>e</sup>	45.51	—	—	—	—	—	—
7-3/4	46.10	7.750	46.10	0.595	6.560	6.435	45.51	—	—	—	—	—	—
8-5/8	24.00	8.625	24.00	0.264	8.097	7.972	23.60	23.60	—	—	—	—	—
8-5/8	28.00	8.625	28.00	0.304	8.017	7.892	27.04	22.20	—	—	—	—	—
8-5/8	32.00	8.625	32.00	0.352	7.921	7.875 <sup>e</sup>	31.13	20.80	27.60	28.30	6.03	13.20	8.80
8-5/8	32.00	8.625	32.00	0.352	7.921	7.796	31.13	20.80	27.60	28.20	6.03	13.20	8.80
8-5/8	36.00	8.625	36.00	0.400	7.825	7.700	35.17	19.40	25.60	26.20	4.03	7.60	4.20
8-5/8	40.00	8.625	40.00	0.450	7.725	7.625 <sup>e</sup>	39.33	—	23.80	24.20	2.03	4.00	0.60
8-5/8	40.00	8.625	40.00	0.450	7.725	7.600	39.33	—	23.80	24.20	2.03	4.00	0.60
8-5/8	44.00	8.625	44.00	0.500	7.625	7.500	43.43	—	21.80	22.20	0.03	1.60	-1.80
8-5/8	49.00	8.625	49.00	0.557	7.511	7.286	48.04	—	19.60	19.80	-2.37	-0.80	-4.20
9-5/8	32.30	9.625	32.30	0.312	9.001	8.845	31.06	24.40	—	—	—	—	—
9-5/8	36.00	9.625	36.00	0.352	8.921	8.765	34.89	23.00	32.00	31.00	6.48	—	—
9-5/8	40.00	9.625	40.00	0.395	8.835	8.750 <sup>e</sup>	38.97	21.40	30.00	29.00	4.48	10.60	7.20
9-5/8	40.00	9.625	40.00	0.395	8.835	8.679	38.97	21.40	30.00	29.00	4.48	10.60	7.20
9-5/8	43.50	9.625	43.50	0.435	8.755	8.599	42.73	—	28.20	27.20	2.68	5.40	2.00
9-5/8	47.00	9.625	47.00	0.472	8.681	8.525	46.18	—	26.60	25.60	1.08	2.20	-1.20
9-5/8	53.50	9.625	53.50	0.545	8.535	8.500 <sup>e</sup>	52.90	—	23.40	22.40	-2.12	-1.20	-4.60
9-5/8	53.50	9.625	53.50	0.545	8.535	8.379	52.90	—	23.40	22.40	-2.12	-1.20	-4.60
9-5/8	58.40	9.625	58.40	0.595	8.435	8.375 <sup>e</sup>	57.44	—	21.50	20.13	-4.40	—	—
9-5/8	58.40	9.625	58.40	0.595	8.435	8.279	57.44	—	21.50	20.13	-4.40	—	—
9-5/8	59.40	9.625	59.40	0.609	8.407	8.251	58.70	—	—	—	—	—	—
9-5/8	64.90	9.625	64.90	0.672	8.281	8.125	64.32	—	—	—	—	—	—
9-5/8	70.30	9.625	70.30	0.734	8.157	8.001	69.76	—	—	—	—	—	—
9-5/8	75.60	9.625	75.60	0.797	8.031	7.875	75.21	—	—	—	—	—	—
10-3/4	32.75	10.750	32.75	0.279	10.192	10.036	31.23	29.00	—	—	—	—	—
10-3/4	40.50	10.750	40.50	0.350	10.050	9.894	38.91	26.40	—	34.40	7.21	—	—
10-3/4	45.50	10.750	45.50	0.400	9.950	9.875 <sup>e</sup>	44.26	24.40	—	31.80	4.61	21.20	—
10-3/4	45.50	10.750	45.50	0.400	9.950	9.794	44.26	24.40	—	31.80	4.61	21.20	—
10-3/4	51.00	10.750	51.00	0.450	9.850	9.694	49.55	22.60	—	29.40	2.21	18.40	—
10-3/4	55.50	10.750	55.50	0.495	9.760	9.625 <sup>e</sup>	54.26	20.80	—	27.00	-0.19	15.80	—
10-3/4	55.50	10.750	55.50	0.495	9.760	9.604	54.26	20.80	—	27.00	-0.19	15.80	—
10-3/4	60.70	10.750	60.70	0.545	9.660	9.504	59.45	18.80	—	24.40	—	13.00	—
10-3/4	65.70	10.750	65.70	0.595	9.560	9.404	64.59	16.80	—	22.00	—	—	—
10-3/4	73.20	10.750	73.20	0.672	9.406	9.250	72.40	—	—	—	—	—	—
10-3/4	79.20	10.750	79.20	0.734	9.282	9.126	78.59	—	—	—	—	—	—
10-3/4	85.30	10.750	85.30	0.797	9.156	9.000	84.80	—	—	—	—	—	—

See notes at end of table.

Table E.24 (continued)

Labels <sup>a</sup>		Outside diameter	Nominal linear mass T&C <sup>b, c</sup>	Wall thickness	Inside diameter	Drift diameter	Calculated mass <sup>c</sup>						
							Plain end	$e_m$ , mass gain or loss due to end finishing <sup>d</sup>					
1	2	D in	lb/ft	t in	d in	in		lb		Extreme-line			
								Round thread		Buttress thread		Standard	Optional
1	2	3	4	5	6	7	8	9	10	11	12	13	14
11-3/4	42.00	11.750	42.00	0.333	11.084	11.000 <sup>e</sup>	40.64	29.60	—	—	—	—	—
11-3/4	42.00	11.750	42.00	0.333	11.084	10.928	40.64	29.60	—	—	—	—	—
11-3/4	47.00	11.750	47.00	0.375	11.000	10.844	45.60	27.60	—	35.80	—	—	—
11-3/4	54.00	11.750	54.00	0.435	10.880	10.724	52.62	25.00	—	32.40	—	—	—
11-3/4	60.00	11.750	60.00	0.489	10.772	10.625 <sup>e</sup>	58.87	22.60	—	29.60	—	—	—
11-3/4	60.00	11.750	60.00	0.489	10.772	10.616	58.87	22.60	—	29.60	—	—	—
11-3/4	65.00	11.750	65.00	0.534	10.682	10.625 <sup>e</sup>	64.03	—	—	—	—	—	—
11-3/4	65.00	11.750	65.00	0.534	10.682	10.526	64.03	—	—	—	—	—	—
11-3/4	71.00	11.750	71.00	0.582	10.586	10.430	69.48	—	—	—	—	—	—
13-3/8	48.00	13.375	48.00	0.330	12.715	12.559	46.02	33.20	—	—	—	—	—
13-3/8	54.50	13.375	54.50	0.380	12.615	12.459	52.79	30.80	—	40.20	—	—	—
13-3/8	61.00	13.375	61.00	0.430	12.515	12.359	59.50	28.40	—	36.80	—	—	—
13-3/8	68.00	13.375	68.00	0.480	12.415	12.259	66.17	25.80	—	33.60	—	—	—
13-3/8	72.00	13.375	72.00	0.514	12.347	12.250 <sup>e</sup>	70.67	24.20	—	31.60	—	—	—
13-3/8	72.00	13.375	72.00	0.514	12.347	12.191	70.67	24.20	—	31.60	—	—	—
16	65.00	16.000	65.00	0.375	15.250	15.062	62.64	42.60	—	—	—	—	—
16	75.00	16.000	75.00	0.438	15.124	14.936	72.86	38.20	—	45.60	—	—	—
16	84.00	16.000	84.00	0.495	15.010	14.822	82.05	34.20	—	39.60	—	—	—
16	109.00	16.000	109.00	0.656	14.688	14.500	107.60	—	—	—	—	—	—
18-5/8	87.50	18.625	87.50	0.435	17.755	17.567	84.59	73.60	—	86.40	—	—	—
20	94.00	20.000	94.00	0.438	19.124	18.936	91.59	47.00	61.20	54.80	—	—	—
20	106.50	20.000	106.50	0.500	19.000	18.812	104.23	41.60	54.80	48.40	—	—	—
20	133.00	20.000	133.00	0.635	18.730	18.542	131.45	30.00	40.60	35.20	—	—	—

See Figures D.1, D.2, D.3 and D.8.

<sup>a</sup> Labels are for information and assistance in ordering.

<sup>b</sup> Nominal linear masses, threaded and coupled (col. 4) are shown for information only.

<sup>c</sup> The densities of martensitic chromium steels (L80 Types 9Cr and 13Cr) are less than those of carbon steels. The masses shown are therefore not accurate for martensitic chromium steels. A mass correction factor of 0.989 may be used.

<sup>d</sup> Mass gain or loss due to end finishing. See 8.5.

<sup>e</sup> Drift diameter for most common bit size. This drift diameter shall be specified on the purchase agreement and marked on the pipe. See 8.10 for drift requirements.

**Table E.25 — Dimensions and masses for standard tubing and for tubing threaded with API non-upset, external upset and integral joint tubing connections**

Labels <sup>a</sup>				Outside dia.	Nominal linear masses <sup>b, c</sup>			Wall thickness	Inside dia.	Calculated mass <sup>c</sup>				
										Plain end	$e_m$ , mass gain or loss due to end finishing <sup>d</sup>			
1	2			$D$ in	Non-upset T&C lb/ft	Ext. upset T&C lb/ft	Integral joint lb/ft	$t$ in	$d$ in		$w_{pe}$ lb/ft	lb		
	NU T&C	EU T&C	IJ							Non-upset		External upset <sup>e</sup> Regular	Special-clearance	
1	2	3	4	5	6	7	8	9	10	11	12	13	14	15
1.050	1.14	1.20	—	1.050	1.14	1.20	—	0.113	0.824	1.13	0.20	1.40	—	—
1.050	1.48	1.54	—	1.050	1.48	1.54	—	0.154	0.742	1.48	—	1.32	—	—
1.315	1.70	1.80	1.72	1.315	1.70	1.80	1.72	0.133	1.049	1.68	0.40	1.40	—	0.20
1.315	2.19	2.24	—	1.315	2.19	2.24	—	0.179	0.957	2.17	—	1.35	—	—
1.660	2.09	—	2.10	1.660	—	—	2.10	0.125	1.410	2.05	—	—	—	0.20
1.660	2.30	2.40	2.33	1.660	2.30	2.40	2.33	0.140	1.380	2.27	0.80	1.60	—	0.20
1.660	3.03	3.07	—	1.660	3.03	3.07	—	0.191	1.278	3.00	—	1.50	0.20	—
1.900	2.40	—	2.40	1.900	—	—	2.40	0.125	1.650	2.37	—	—	—	0.20
1.900	2.75	2.90	2.76	1.900	2.75	2.90	2.76	0.145	1.610	2.72	0.60	2.00	—	0.20
1.900	3.65	3.73	—	1.900	3.65	3.73	—	0.200	1.500	3.63	—	2.03	—	—
1.900	4.42	—	—	1.900	4.42	—	—	0.250	1.400	4.41	—	—	—	—
1.900	5.15	—	—	1.900	5.15	—	—	0.300	1.300	5.13	—	—	—	—
2.063	3.24	—	3.25	2.063	—	—	3.25	0.156	1.751	3.18	—	—	—	0.20
2.063	4.50	—	—	2.063	—	—	—	0.225	1.613	4.42	—	—	—	—
2-3/8	4.00	—	—	2.375	4.00	—	—	0.167	2.041	3.94	1.60	—	—	—
2-3/8	4.60	4.70	—	2.375	4.60	4.70	—	0.190	1.995	4.44	1.60	4.00	2.96	—
2-3/8	5.80	5.95	—	2.375	5.80	5.95	—	0.254	1.867	5.76	1.40	3.60	2.56	—
2-3/8	6.60	—	—	2.375	6.60	—	—	0.295	1.785	6.56	—	—	—	—
2-3/8	7.35	7.45	—	2.375	7.35	7.45	—	0.336	1.703	7.32	—	—	—	—
2-7/8	6.40	6.50	—	2.875	6.40	6.50	—	0.217	2.441	6.17	3.20	5.60	3.76	—
2-7/8	7.80	7.90	—	2.875	7.80	7.90	—	0.276	2.323	7.67	2.80	5.80	3.92	—
2-7/8	8.60	8.70	—	2.875	8.60	8.70	—	0.308	2.259	8.45	2.60	5.00	3.16	—
2-7/8	9.35	9.45	—	2.875	9.35	9.45	—	0.340	2.195	9.21	—	—	—	—
2-7/8	1.050	—	—	2.875	10.50	—	—	0.392	2.091	10.40	—	—	—	—
2-7/8	11.50	—	—	2.875	11.50	—	—	0.440	1.995	11.45	—	—	—	—
3-1/2	7.70	—	—	3.500	7.70	—	—	0.216	3.068	7.58	5.40	—	—	—
3-1/2	9.20	9.30	—	3.500	9.20	9.30	—	0.254	2.992	8.81	5.00	9.20	5.40	—
3-1/2	10.20	—	—	3.500	10.20	—	—	0.289	2.922	9.92	4.80	—	—	—
3-1/2	12.70	12.95	—	3.500	12.70	12.95	—	0.375	2.750	12.53	4.00	8.20	4.40	—
3-1/2	14.30	—	—	3.500	14.30	—	—	0.430	2.640	14.11	—	—	—	—
3-1/2	15.50	—	—	3.500	15.50	—	—	0.476	2.548	15.39	—	—	—	—
3-1/2	17.00	—	—	3.500	17.00	—	—	0.530	2.440	16.83	—	—	—	—
4	9.50	—	—	4.000	9.50	—	—	0.226	3.548	9.12	6.20	—	—	—
4	10.70	11.00	—	4.000	—	11.00	—	0.262	3.476	10.47	—	10.60	—	—
4	13.20	—	—	4.000	13.20	—	—	0.330	3.340	12.95	—	—	—	—
4	16.10	—	—	4.000	16.10	—	—	0.415	3.170	15.90	—	—	—	—
4	18.90	—	—	4.000	18.90	—	—	0.500	3.000	18.71	—	—	—	—
4	22.20	—	—	4.000	22.20	—	—	0.610	2.780	22.11	—	—	—	—
4-1/2	12.60	12.75	—	4.500	12.60	12.75	—	0.271	3.958	12.25	6.00	13.20	—	—
4-1/2	15.20	—	—	4.500	15.20	—	—	0.337	3.826	15.00	—	—	—	—
4-1/2	17.00	—	—	4.500	17.00	—	—	0.380	3.740	16.77	—	—	—	—
4-1/2	18.90	—	—	4.500	18.90	—	—	0.430	3.640	18.71	—	—	—	—
4-1/2	21.50	—	—	4.500	21.50	—	—	0.500	3.500	21.38	—	—	—	—
4-1/2	23.70	—	—	4.500	23.70	—	—	0.560	3.380	23.59	—	—	—	—
4-1/2	26.10	—	—	4.500	26.10	—	—	0.630	3.240	26.06	—	—	—	—

See Figures D.4, D.5 and D.7.

<sup>a</sup> Labels are for information and assistance in ordering.

<sup>b</sup> Nominal linear masses, threaded and coupled (Col. 6, 7 and 8) are shown for information only.

<sup>c</sup> The densities of martensitic chromium (L80 Types 9Cr and 13Cr) are different from carbon steels. The masses shown are therefore not accurate for martensitic chromium steels. A mass correction factor of 0.989 may be used.

<sup>d</sup> Mass gain or loss due to end finishing. See 8.5.

<sup>e</sup> The length of the upset may alter the mass gain or loss due to end finishing.

**Table E.26 — API extreme-line casing upset end dimensions**

Labels		Outside diameter <i>D</i> in	Nominal linear mass, upset and threaded lb/ft	Finished pin-and-box dimensions <sup>a</sup>									Drift dia'r for finished upset member in	Drift diameter for full length drifting min. in
				Pin-and-box outside diameter (turned) −0.010 +0.020 in		Pin inside diameter (bored) −0.015 +0.015 in	Box inside diameter (bored) 0 +0.030 in	Pin-and-box made-up (power-tight) <sup>b</sup> in			Standard and optional	Standard and optional		
				Standard <i>M</i>	Optional <i>M</i>	Standard and optional <i>B</i>	Standard and optional <i>D</i>	Outside diameter −0.010 +0.020 in		Inside diameter −0.005 +0.010 in				
1	2	3	4	5	6	7	8	9	10	11	12	13		
5	15.00	5.000	15.00	5.360	—	4.208	4.235	5.360	—	4.198	4.183	4.151		
5	18.00	5.000	18.00	5.360	—	4.208	4.235	5.360	—	4.198	4.183	4.151		
5-1/2	15.50	5.500	15.50	5.860	5.780	4.746	4.773	5.860	5.780	4.736	4.721	4.653		
5-1/2	17.00	5.500	17.00	5.860	5.780	4.711	4.738	5.860	5.780	4.701	4.686	4.65		
5-1/2	20.00	5.500	20.00	5.860	5.780	4.711	4.738	5.860	5.780	4.701	4.686	4.653		
5-1/2	23.00	5.500	23.00	5.860	5.780	4.619	4.647	5.860	5.780	4.610	4.595	4.545		
6-5/8	24.00	6.625	24.00	7.000	6.930	5.792	5.818	7.000	6.930	5.781	5.766	5.730		
6-5/8	28.00	6.625	28.00	7.000	6.930	5.741	5.768	7.000	6.930	5.731	5.716	5.666		
6-5/8	32.00	6.625	32.00	7.000	6.930	5.624	5.652	7.000	6.930	5.615	5.600	5.550		
7	23.00	7.000	23.00	7.390	7.310	6.182	6.208	7.390	7.310	6.171	6.156	6.151		
7	26.00	7.000	26.00	7.390	7.310	6.182	6.208	7.390	7.310	6.171	5.156	6.151		
7	29.00	7.000	29.00	7.390	7.310	6.134	6.160	7.390	7.310	6.123	6.108	6.059		
7	32.00	7.000	32.00	7.390	7.310	6.042	6.069	7.390	7.310	6.032	6.017	5.969		
7	35.00	7.000	35.00	7.530	7.390	5.949	5.977	7.530	7.390	5.940	5.925	5.879		
7	38.00	7.000	38.00	7.530	7.390	5.869	5.897	7.530	7.390	5.860	5.845	5.795		
7-5/8	26.40	7.625	26.40	8.010	7.920	6.782	6.807	8.010	7.920	6.770	6.755	6.750		
7-5/8	29.70	7.625	29.70	8.010	7.920	6.782	6.807	8.010	7.920	6.770	6.755	6.750		
7-5/8	33.70	7.625	33.70	8.010	7.920	6.716	6.742	8.010	7.920	6.705	6.690	6.640		
7-5/8	39.00	7.625	39.00	8.010	7.920	6.575	6.602	8.010	7.920	6.565	6.550	6.500		
8-5/8	32.00	8.625	32.00	9.120	9.030	7.737	7.762	9.120	9.030	7.725	7.710	7.700		
8-5/8	36.00	8.625	36.00	9.120	9.030	7.737	7.762	9.120	9.030	7.725	7.710	7.700		
8-5/8	40.00	8.625	40.00	9.120	9.030	7.674	7.700	9.120	9.030	7.663	7.648	7.600		
8-5/8	44.00	8.625	44.00	9.120	9.030	7.575	7.602	9.120	9.030	7.565	7.550	7.500		
8-5/8	49.00	8.625	49.00	9.120	9.030	7.460	7.488	9.120	9.030	7.451	7.436	7.386		
9-5/8	40.00	9.625	40.00	10.100	10.020	8.677	8.702	10.100	10.020	8.665	8.650	8.599		
9-5/8	43.50	9.625	43.50	10.100	10.020	8.677	8.702	10.100	10.020	8.665	8.650	8.599		
9-5/8	47.00	9.625	47.00	10.100	10.020	8.633	8.658	10.100	10.020	8.621	8.606	8.525		
9-5/8	53.50	9.625	53.50	10.100	10.020	8.485	8.512	10.100	10.020	8.475	8.460	8.379		
10%	45.50	10.750	45.50	11.460	—	9.829	9.854	11.460	—	9.819	9.804	9.794		
10%	51.00	10.750	51.00	11.460	—	9.729	9.754	11.460	—	9.719	9.704	9.694		
10%	55.50	10.750	55.50	11.460	—	9.639	9.664	11.460	—	9.629	9.614	9.604		
10%	60.70	10.750	60.70	11.460	—	9.539	9.564	11.460	—	9.529	9.514	9.504		

See Table E.24 and Figure D.8.

<sup>a</sup> Due to the nature of extreme-line casing, certain dimensional symbols and nomenclature differ from those for similar details for other pipe covered by this International Standard.

<sup>b</sup> Shown for reference.

<sup>c</sup> Made-up joint *D* is the same as the outside diameter dimension *M*.

**Table E.27 — External upset tubing dimensions for API connections, Groups 1, 2, and 3**

Labels <sup>a</sup>		Size Outside diameter <i>D</i>	Nominal linear mass, threaded and coupled <sup>b</sup>	Upset			
				Outside diameter <sup>c</sup> <i>D</i> <sub>4</sub>	Length from end of pipe to start of taper <sup>d, c</sup> <i>L</i> <sub>eu</sub>	Length from end of pipe to end of taper <sup>e</sup> <i>L</i> <sub>a</sub>	Length from end of pipe to start of pipe body <sup>e</sup> <i>L</i> <sub>b</sub>
1	2	in	lb/ft	in +0.0625 0	in 0 -1	in	in max.
1	2	3	4	5	6	7	8
1.050	1.20	1.050	1.20	1.315	2 3/8	—	—
1.050	1.54	1.050	1.54	1.315	2 3/8	—	—
1.315	1.80	1.315	1.80	1.469	2 1/2	—	—
1.315	2.24	1.315	2.24	1.469	2 1/2	—	—
1.660	2.40	1.660	2.40	1.812	2 5/8	—	—
1.660	3.07	1.660	3.07	1.812	2 5/8	—	—
1.900	2.90	1.900	2.90	2.094	2 11/16	—	—
1.900	3.73	1.900	3.73	2.094	2 11/16	—	—
2-3/8	4.70	2.375	4.70	2.594	4.00	6.00	10.00
2-3/8	5.95	2.375	5.95	2.594	4.00	6.00	10.00
2-3/8	7.45	2.375	7.45	2.594	4.00	6.00	10.00
2-7/8	6.50	2.875	6.50	3.094	4 1/4	6 1/4	10 1/4
2-7/8	7.90	2.875	7.90	3.094	4 1/4	6 1/4	10 1/4
2-7/8	8.70	2.875	8.70	3.094	4 1/4	6 1/4	10 1/4
2-7/8	9.45	2.875	9.45	3.094	4 1/4	6 1/4	10 1/4
3-1/2	9.30	3.500	9.30	3.750	4 1/2	6 1/2	10 1/2
3-1/2	12.95	3.500	12.95	3.750	4 1/2	6 1/2	10 1/2
4	11.00	4.000	11.00	4.250	4 1/2	6 1/2	10 1/2
4-1/2	12.75	4.500	12.75	4.750	4 3/4	6 3/4	10 3/4

See also Figures D.5 and D.6.

<sup>a</sup> Labels are for information and assistance in ordering.

<sup>b</sup> The densities of martensitic chromium steels (L80 9Cr and 13Cr) are different from carbon steels. The masses shown are therefore not accurate for chromium steels. A mass correction factor of 0.989 may be used.

<sup>c</sup> The minimum outside diameter of upset *D*<sub>4</sub> is limited by the minimum length of full-crest threads. See API Spec 5B.

<sup>d</sup> For pup joints only, the length tolerance on *L*<sub>eu</sub> is:  $\begin{matrix} +4 \\ -1 \end{matrix}$  in. The length on *L*<sub>b</sub> may be 4 in longer than specified.

<sup>e</sup> For extended length upsets on external upset tubing, add 1 in to the dimensions in columns 6, 7 and 8.

**Table E.28 — Integral joint tubing dimensions for API connections, Groups 1 and 2**

Labels		Outside dia. <i>D</i> in	Nominal linear mass <sup>a</sup> T&C lb/ft	Upset dimensions in								
				Pin				Box				
				Outside dia. <sup>b</sup> <i>D</i> <sub>4</sub> +0.0625 0	Inside dia. <sup>c</sup> <i>d</i> <sub>iu</sub> +0.015 0	Length <i>L</i> <sub>iu</sub> min.	Length of taper <i>m</i> <sub>iu</sub> min.	Outside diameter <i>W</i> <sub>b</sub> +0.005 -0.025	Length <i>L</i> <sub>eu</sub> min.	Length of taper <i>m</i> <sub>eu</sub>	Diameter of recess <i>Q</i>	Width of face <i>b</i> min.
1	2	3	4	5	6	7	8	9	10	11	12	13
1.315	1.72	1.315	1.72	—	0.970	1 3/8	¼	1.550	1.750	1	1.378	1/32
1.660	2.10	1.660	2.10	—	1.301	1 ½	¼	1.880	1.875	1	1.723	1/32
1.660	2.33	1.660	2.33	—	1.301	1 ½	¼	1.880	1.875	1	1.723	1/32
1.900	2.40	1.900	2.40	—	1.531	1 5/8	¼	2.110	2.000	1	1.963	1/32
1.900	2.76	1.900	2.76	—	1.531	1 5/8	¼	2.110	2.000	1	1.963	1/32
2.063	3.25	2.063	3.25	2.094	1.672	1 11/16	1/4	2.325	2.125	1	2.156	1/32

See also Figure D.7.

- <sup>a</sup> Nominal linear masses, upset and threaded, are shown for information only.
- <sup>b</sup> The minimum outside diameter *D*<sub>4</sub> is limited by the minimum length of full-crest threads. See API Spec 5B.
- <sup>c</sup> The minimum diameter *d*<sub>iu</sub> is limited by the drift test.

**Table E.29 — Plain-end liners — Dimensions and masses for Grade J55**

Labels		Outside diameter <i>D</i> in	Plain-end linear mass lb/ft	Wall thickness <i>t</i> in	Inside diameter <i>d</i> in
1	2	3	4	5	6
1	2	3	4	5	6
3-1/2	9.91	3.500	9.91	0.289	2.922
4	11.34	4.000	11.34	0.286	3.428
4-1/2	13.04	4.500	13.04	0.290	3.920
5	17.93	5.000	17.93	0.362	4.276
5-1/2	19.81	5.500	19.81	0.361	4.778
6-5/8	27.65	6.625	27.65	0.417	5.791

**Table E.30 — Range lengths**

Dimensions in feet

	Range 1	Range 2	Range 3
<b>CASING AND LINERS</b>			
Total range length, inclusive	16.0 to 25.0	25.0 to 34.0	34.0 to 48.0
Range length for 95 % or more of carload <sup>a</sup>			
Permissible variation, max.	6.0	5.0	6.0
Permissible length, min.	18.0	28.0	36.0
<b>THREADED AND COUPLED TUBING AND CASING USED AS TUBING</b>			
Total range length, inclusive	20.0 to 24.0 <sup>b</sup>	28.0 to 32.0 <sup>c</sup>	38.0 to 42.0 <sup>d</sup>
Range length for 100 % of carload <sup>a</sup>			
Permissible variation, max.	2.0	2.0	2.0
<b>INTEGRAL JOINT TUBING (including IJ/UF and IJ/SF)</b>			
Total range length, inclusive	20.0 to 26.0 <sup>b</sup>	28.0 to 34.0	38.0 to 45.0
Range length for 100 % of carload <sup>a</sup>			
Permissible variation, max.	2.0	2.0	2.0
<b>PUP JOINTS</b>	Lengths 2; 3; 4; 6; 8; 10 and 12 <sup>e</sup>		
	Tolerance ± 3 in		
<sup>a</sup> Carload tolerances shall not apply to order items of less than 40 000 lb of pipe. For any carload of 40 000 lb or more of pipe that is shipped to the final destination without transfer or removal from the car, the tolerance shall apply to each car. For any order item consisting of more than 40 000 lb of pipe that is shipped from the manufacturer's facility by rail, but not to the final destination, the carload tolerance shall apply to the overall quantity of pipe shipped on the order item, but not to the individual carloads. <sup>b</sup> By agreement between purchaser and manufacturer the maximum length may be increased to 28.0 ft. <sup>c</sup> By agreement between purchaser and manufacturer the maximum length may be increased to 34.0 ft. <sup>d</sup> By agreement between purchaser and manufacturer, the maximum length may be increased to 45.0 ft. <sup>e</sup> 2 ft pup joints may be furnished up to 3 ft long by agreement between purchaser and manufacturer, and lengths other than those listed may be furnished by agreement between purchaser and manufacturer.			

**Table E.31 — Standard drift size**

Dimensions in inches

Product and Label 1	Standard drift mandrel size		
	min.		
	Length	Diameter	
Casing <sup>a</sup> and liners			
	< 9-5/8	6	$d - 1/8$
	≥ 9-5/8 to ≤ 13-3/8	12	$d - 5/32$
	> 13-3/8	12	$d - 3/16$
Tubing <sup>b</sup>			
	≤ 2-7/8	42	$d - 3/32$
	> 2-7/8	42	$d - 1/8$
<sup>a</sup> The minimum diameter of the drift mandrel for extreme-line casing shall be as shown in cols. 12 and 13, Table E.26. <sup>b</sup> Integral-joint tubing shall be tested before upsetting with a drift mandrel as shown, and shall also be drift-tested at the pin end, after upsetting, with a cylindrical drift mandrel 42 in in length and $d_{iu} - 0.015$ in diameter (see Table E.28, col. 6 for $d_{iu}$ ).			

**Table E.32 — Alternative drift size**

Labels		Outside diameter <i>D</i> in	Product linear mass lb/ft	Alternative drift mandrel size in min.	
1	2			Length	Diameter
1	2	3	4	5	6
7	23.00	7.000	23.0	6	6.250
7	32.00	7.000	32.0	6	6.000
7-3/4	46.10	7.750	46.1	6	6.500
8-5/8	32.00	8.625	32.0	6	7.875
8-5/8	40.00	8.625	40.0	6	7.625
9-5/8	40.00	9.625	40.0	12	8.750
9-5/8	53.50	9.625	53.5	12	8.500
9-5/8	58.40	9.625	58.4	12	8.375
10-3/4	45.50	10.750	45.5	12	9.875
10-3/4	55.50	10.750	55.5	12	9.625
11-3/4	42.00	11.750	42.0	12	11.000
11-3/4	60.00	11.750	60.0	12	10.625
11-3/4	65.00	11.750	65.0	12	10.625
13-3/8	72.00	13.375	72.0	12	12.250

**Table E.33 — Maximum permissible depth of linear imperfections**

Grade	Depth as % of specified wall thickness	
	External	Internal
H40 – J55 – K55 – M65 – N80 Type 1 – N80Q L80 – C95 – P110 to A.10 (SR16)	12.5 %	12.5 %
C90 – T95 – P110 – Q125	5 %	5 %
P110 to A.10 (SR16) and A.3 (SR2)	5 %	5 %



**Table E.34 — Upset products — Maximum permissible depth of imperfections**

	Surface	Depth	Measurement notes
<b>A Extreme-line casing, integral joint and external upset tubing (see Figures D.8, D.7 and D.5)</b>			
A.1	All surfaces of upset and upset run-out interval, except as stated below	12.5 % $t$	Percentage of specified pipe body wall thickness $t$ ; for non-linear imperfections; for all groups of pipe.
		12.5 % $t$	Percentage of specified pipe body wall thickness $t$ ; for linear imperfections; for Group 1 and Group 2 (except C90 and T95) pipe.
		5 % $t$	Percent of specified pipe body wall thickness $t$ ; for linear imperfections; for Group 3, Group 4 and Grades C90 and T95 pipe.
A.2 The minimum wall thickness in the upset run-out interval, and the maximum combined effect of coincident internal and external imperfections in all areas, shall not total less than 87.5 % of the specified wall thickness.			
<b>B Extreme-line casing (see Figure D.8)</b>			
B.1	Box-end external surface	0.010 in	For Label 1: 7-5/8 and smaller sizes. From end of pipe to a plane 4 ¾ in from the end.
		0.010 in	For Label 1: Larger than 7-5/8. From end of pipe to a plane 6 ½ in from the end.
B.2	Pin-end internal surface	0.015 in	From end of pipe to plane of external shoulder (bored).
B.3 All machined surfaces of the box shall be free of seams, laps and cracks. The pin-and-box shall be free of any imperfections which break the continuity of the threads or seals.			
<b>C Integral joint tubing (see Figure D.7)</b>			
C.1	Box end external surface	0.010 in	From end of pipe to a plane at a distance equal to the specified minimum dimension $L_{eu}$ (Figure D.7) from end of pipe.
C.2	Pin end internal surface	0.015 in	From end of pipe to a plane at a distance equal to the specified minimum dimension $L_{iu}$ (Figure D.7) from end of pipe.
			For Grades C90 and T95, the maximum permissible depth for linear imperfections shall be 5 % of the specified pipe body wall thickness.
C.3 Upset under-fills in the upset run-out intervals shall not be considered a defect unless the remaining wall thickness (at the upset under-fill) is less than 87.5 % of the specified pipe body wall thickness.			

**Table E.35 — API round-thread casing coupling — Dimensions, tolerances and masses**

Label 1	Size <sup>a</sup>	Outside diameter <i>W</i> <sup>b, c</sup>	Minimum length in		Diameter of recess <i>Q</i> <sup>d</sup>	Width of bearing face <i>b</i>	Mass lb	
	Outside diameter <i>D</i> in		Short <i>N<sub>L</sub></i>	Long <i>N<sub>L</sub></i>			Short	Long
1	2	3	4	5	6	7	8	9
4-1/2	4.500	5.000	6 1/4	7	4 19/32	5/32	7.98	9.16
5	5.000	5.563	6 1/2	7 3/4	5 3/32	3/16	10.27	12.68
5-1/2	5.500	6.050	6 3/4	8	5 19/32	1/8	11.54	14.15
6-5/8	6.625	7.390	7 1/4	8 3/4	6 23/32	1/4	20.11	25.01
7	7.000	7.656	7 1/4	9	7 3/32	3/16	18.49	23.87
7-5/8	7.625	8.500	7 1/2	9 1/4	7 25/32	7/32	27.11	34.46
8-5/8	8.625	9.625	7 3/4	10	8 25/32	1/4	35.79	47.77
9-5/8	9.625	10.625	7 3/4	10 1/2	9 25/32	1/4	39.75	56.11
10-3/4	10.750	11.750	8	—	10 29/32	1/4	45.81	—
11-3/4	11.750	12.750	8	—	11 29/32	1/4	49.91	—
13-3/8	13.375	14.375	8	—	13 17/32	7/32	56.57	—
16	16.000	17.000	9	—	16 7/32	7/32	76.96	—
18-5/8	18.625	20.000	9	—	18 27/32	7/32	119.07	—
20	20.000	21.000	9	11 1/2	20 7/32	7/32	95.73	126.87

See also Figures D.1 and D.2

<sup>a</sup> The size designation for the coupling is the same as the size designation for the pipe on which the coupling is used.

<sup>b</sup> Groups 1, 2 and 3: Tolerance on outside diameter, *W*, ± 1 % but not greater than ± 1/8 in.

<sup>c</sup> Group 4: Tolerance on outside diameter *W*, ± 1 % but not greater than  $\begin{matrix} +1/8 \\ -1/16 \end{matrix}$  in.

<sup>d</sup> Tolerance on diameter of recess, *Q*, for all groups is  $\begin{matrix} +0.031 \\ 0 \end{matrix}$  in.

**Table E.36 — API buttress thread casing coupling — Dimensions, tolerances and masses**

Label 1	Size <sup>a</sup>	Outside diameter		Minimum length $N_L$	Diameter of counterbore $Q$	Width of bearing face $b$	Mass lb	
	Outside diameter $D$	Regular $W$ <sup>b, c</sup>	Special-clearance $W_C$ <sup>d</sup>				Regular	Special clearance
	in	in	in	in	in	in		
1	2	3	4	5	6	7	8	9
4-1/2	4.500	5.000	4.875	8 7/8	4.640	1/8	10.12	7.68
5	5.000	5.563	5.375	9 1/8	5.140	5/32	13.00	8.82
5-1/2	5.500	6.050	5.875	9 1/4	5.640	5/32	14.15	9.85
6-5/8	6.625	7.390	7.000	9 5/8	6.765	1/4	24.49	12.46
7	7.000	7.656	7.375	10	7.140	7/32	23.24	13.84
7-5/8	7.625	8.500	8.125	10 3/8	7.765	5/16	34.88	20.47
8-5/8	8.625	9.625	9.125	10 5/8	8.765	3/8	45.99	23.80
9-5/8	9.625	10.625	10.125	10 5/8	9.765	3/8	51.05	26.49
10-3/4	10.750	11.750	11.250	10 5/8	10.890	3/8	56.74	29.52
11-3/4	11.750	12.750	—	10 5/8	11.890	3/8	61.80	—
13-3/8	13.375	14.375	—	10 5/8	13.515	3/8	70.03	—
16	16.000	17.000	—	10 5/8	16.154	3/8	88.81	—
18-5/8	18.625	20.000	—	10 5/8	18.779	3/8	138.18	—
20	20.000	21.000	—	10 5/8	20.154	3/8	110.45	—

See also Figure D.3.

<sup>a</sup> The size designation for the coupling is the same as the size designation for the pipe on which the coupling is used.

<sup>b</sup> Groups 1, 2 and 3: Tolerance on outside diameter  $W$ ,  $\pm 1\%$  but not greater than  $\pm 1/8$  in.

<sup>c</sup> Group 4: Tolerance on outside diameter  $W$ ,  $\pm 1\%$  but not greater than  $\begin{matrix} +1/8 \\ -1/16 \end{matrix}$  in.

<sup>d</sup> Groups 1, 2 and 3: Tolerance on outside diameter  $W_C$  is  $\begin{matrix} -1/64 \\ +1/32 \end{matrix}$  in.

**Table E.37 — API non-upset tubing coupling — Dimensions, tolerances and masses**

Label 1	Size <sup>a</sup>	Outside diameter $W$ <sup>b</sup>	Minimum length $N_L$	Diameter of recess $Q$	Width of bearing face $b$	Maximum bearing face diameter, special bevel $Bf$	Mass lb
	Outside diameter $D$						
	in	in	in	in	in	in	
1	2	3	4	5	6	7	8
1.050	1.050	1.313	3 3/16	1.113	1/16	1.181	0.51
1.315	1.315	1.660	3 1/4	1.378	3/32	1.488	0.84
1.660	1.660	2.054	3 1/2	1.723	1/8	1.857	1.29
1.900	1.900	2.200	3 3/4	1.963	1/16	2.050	1.23
2-3/8	2.375	2.875	4 1/4	2.438	3/16	2.625	2.82
2-7/8	2.875	3.500	5 1/8	2.938	3/16	3.188	5.15
3-1/2	3.500	4.250	5 5/8	3.563	3/16	3.875	8.17
4	4.000	4.750	5 3/4	4.063	3/16	4.375	9.58
4-1/2	4.500	5.200	6 1/8	4.563	3/16	4.850	10.77

See Figure D.4.

<sup>a</sup> The size designation for the coupling is the same as the size designation for the pipe on which the coupling is used.

<sup>b</sup> Tolerance on outside diameter  $W$ ,  $\pm 1\%$ .

**Table E.38 — API external-upset tubing coupling — Dimensions, tolerances and masses**

Label 1	Size <sup>a</sup>	Outside diameter		Minimum length	Diameter of recess	Width of bearing face, regular	Maximum bearing face diameter		Mass	
	Outside diameter	Regular & special bevel	Special clearance				<i>B<sub>f</sub></i>		Regular	Special clearance
							Special bevel	Special-clearance		
<i>D</i> in	<i>W</i> <sup>b</sup> in	<i>W<sub>c</sub></i> <sup>c</sup> in	<i>N<sub>L</sub></i> in	<i>Q</i> in	<i>b</i> in	in	in			
1	2	3	4	5	6	7	8	9	10	11
1.050	1.050	1.660	—	3 ¼	1.378	3/32	1.488	—	0.84	—
1.315	1.315	1.900	—	3 ½	1.531	3/32	1.684	—	1.26	—
1.660	1.660	2.200	—	3 ¾	1.875	1/8	2.006	—	1.49	—
1.900	1.900	2.500	—	3 7/8	2.156	1/8	2.297	—	1.85	—
2-3/8	2.375	3.063	2.910	4 7/8	2.656	5/32	2.828	2.752	3.43	2.35
2-7/8	2.875	3.668	3.460	5 ¼	3.156	7/32	3.381	3.277	5.30	3.42
3-1/2	3.500	4.500	4.180	5 ¾	3.813	¼	4.125	3.965	9.03	5.24
4	4.000	5.000	—	6	4.313	¼	4.625	—	10.63	—
4-1/2	4.500	5.563	—	6 1/4	4.813	¼	5.156	—	13.33	—

See also Figure D.5.

<sup>a</sup> The size designation for the coupling is the same as the size designation for the pipe on which the coupling is used.

<sup>b</sup> Tolerance on outside diameter *W*, ± 1 %.

<sup>c</sup> Tolerance on outside diameter *W<sub>c</sub>* ± 0.015 in.

**Table E.39 — Permissible depth of external imperfections on coupling**

Dimensions in inches

Coupling for Label 1		Group 1 Group 2 (except C90 and T95) Group 3		Group 2 (C90 and T95) Group 4
		Pits and round-bottom gouges	Grip marks and sharp-bottom gouges	Pits, round-bottom gouges, sharp-bottom gouges, grip marks
1	2	3	4	5
Tubing	< 3-1/2	0.030	0.025	0.030
	≥ 3-1/2 to ≤ 4-1/2	0.045	0.030	0.035
Casing <sup>a</sup>	< 6-5/8	0.035	0.030	0.030
	≥ 6-5/8 to ≤ 7-5/8	0.045	0.040	0.035
	> 7-5/8	0.060	0.040	0.035

<sup>a</sup> Includes casing used as tubing.

**Table E.40 — Frequency of tensile tests — Casing and tubing**

Group	Label 1	Maximum number of pieces in a lot	Number of tests	
			per lot	per heat
1	2	3	4	5
1	< 6-5/8	400 <sup>a, b</sup>	1	1
	≥ 6-5/8	200 <sup>a, b</sup>	1	1
2	≤ 4-1/2 – Grades M65, L80 Type 1, C95	200 <sup>a, b</sup>	2 <sup>c</sup>	1
	≤ 4-1/2 – Grades L80 9Cr, L80 13Cr	200 <sup>b, d</sup>	2 <sup>c</sup>	—
	≤ 4-1/2 – Grades C90, T95	200 <sup>b, d</sup>	1	—
	> 4-1/2 – Grades M65, L80 Type 1, C95	100 <sup>a, b</sup>	2 <sup>c</sup>	1
	> 4-1/2 – Grades L80 9Cr, L80 13Cr	100 <sup>b, d</sup>	2 <sup>c</sup>	—
	> 4-1/2 – Grades C90, T95	100 <sup>b, d</sup>	1	—
3	< 6 5/8	200 <sup>a, b</sup>	1	1
	≥ 6 5/8	100 <sup>a, b</sup>	1	1
4	All sizes	— <sup>d</sup>	3 <sup>c</sup>	—

For Groups 1, 2 and 3 multiple-length seamless pipe, a length shall be considered as all of the sections cut from a particular multiple length, provided the pipe receives no additional heat treatment after being cut into individual lengths.

NOTE Table includes casing used as tubing.

- <sup>a</sup> See 10.2.1.
- <sup>b</sup> See 10.4.2.
- <sup>c</sup> See 10.4.3.
- <sup>d</sup> See 10.2.2.

**Table E.41 — Frequency of tensile tests — Coupling stock and couplings**

Group	Source of coupling		Maximum number of pieces in a lot	Number of tests	
	Material	Condition when heat-treated		per lot	per heat
1	2	3	4	5	6
Groups 1 & 3	Coupling stock	Coupling stock for pipe ≤ Label 1: 4-1/2	200 <sup>a</sup>	1	1 <sup>b</sup>
		Coupling stock for pipe > Label 1: 4-1/2	100 <sup>a</sup>	1	1 <sup>b</sup>
		Coupling blank	400 <sup>c</sup>	1	—
	Hot forging	Coupling blank	400 <sup>c</sup>	1	—
Group 2 Grades L80 Type 1 and C95	Coupling stock	Coupling stock for pipe ≤ Label 1: 4-1/2	200 <sup>a</sup>	2 <sup>d</sup>	2 <sup>d</sup>
		Coupling stock for pipe > Label 1: 4-1/2	100 <sup>a</sup>	2 <sup>d</sup>	2 <sup>d</sup>
		Coupling blank	400 <sup>c</sup>	2	—
	Hot forging	Coupling blank	400 <sup>c</sup>	2	—
Group 2 Grades L80 9Cr and L80 13Cr	Coupling stock	Coupling stock for pipe ≤ Label 1: 4-1/2	200 <sup>d</sup>	2 <sup>d</sup>	—
		Coupling stock for pipe > Label 1: 4-1/2	100 <sup>d</sup>	2 <sup>d</sup>	—
		Coupling blank	400 <sup>c</sup>	2	—
	Hot forging	Coupling blank	400 <sup>c</sup>	2	—
Group 2 Grades C90 and T95	Coupling stock	Coupling stock for pipe Label 1: All sizes	1 <sup>b</sup>	1	—
		Coupling blank	Label 1: < 9-5/8: 50 <sup>c</sup> Label 1: ≥ 9-5/8: 30 <sup>c</sup>	1	—
	Hot forging	Coupling blank	Label 1: < 9-5/8: 50 <sup>c</sup> Label 1: ≥ 9-5/8: 30 <sup>c</sup>	1	—
Group 4	Coupling stock	Coupling stock for pipe Label 1: All sizes	1 <sup>b</sup>	1	—
		Coupling blank	Label 1: < 9-5/8: 50 <sup>c</sup> Label 1: ≥ 9-5/8: 30 <sup>c</sup>	1	—

<sup>a</sup> See 10.2.1.  
<sup>b</sup> Approximately 50 % from each end.  
<sup>c</sup> See 10.2.3.  
<sup>d</sup> See 10.2.2.

**Table E.42 — Frequency of tensile testing — Pup joints and accessories**

Group	Material <sup>a</sup>		Maximum number of pieces in a lot	Number of tests	
				per lot	per heat
1	2	3	4	5	6
Groups 1 & 3	Group 1: Full-length standard tubing or casing from one or more heats		Label 1: < 6-5/8: 400 Label 1: ≥ 6-5/8: 200	1	1
	Group 3: Full-length standard tubing or casing from one or more heats		Label 1: < 6-5/8: 200 Label 1: ≥ 6-5/8: 100	1	1
	Thick-wall mechanical tube or bar stock from a single heat		Label 1: ≤ 4-1/2: 200 Label 1: > 4-1/2: 100	1	1
	Heat-treated in blanks or individual lengths or hot forgings	Batch heat treatment	100 pup joints or 400 accessories	1	—
Heat-treated in sequential loads or continuous heat treatment		In accordance with 10.2.3	1	—	
Group 2 Grades M65, L80 Type 1, C95	Full-length standard tubing or casing from one or more heats		Label 1: ≤ 4-1/2: 200 Label 1: > 4-1/2: 100	2 <sup>b</sup>	2 <sup>b</sup>
	Thick-wall mechanical tube or bar stock from a single heat		Label 1: ≤ 4-1/2: 200 Label 1: > 4-1/2: 100	2 <sup>b</sup>	2 <sup>b</sup>
	Heat-treated in blanks or individual lengths or hot forgings	Batch heat treatment	100 pup joints or 400 accessories	2	—
		Heat-treated in sequential loads or continuous heat treatment	In accordance with 10.2.3	2	—
Group 2 Grades L80 9Cr L80 13Cr	Full-length standard tubing or casing from one or more heats		Label 1: ≤ 4-1/2: 200 Label 1: > 4-1/2: 100	2 <sup>b</sup>	—
	Thick-wall mechanical tube or bar stock from a single heat		Label 1: ≤ 4-1/2: 200 Label 1: > 4-1/2: 100	2 <sup>b</sup>	—
	Heat-treated in blanks or individual lengths or hot forgings	Batch heat treatment	100 pup joints or 400 accessories	2	—
		Heat-treated in sequential loads or continuous heat treatment	In accordance with 10.2.3	2	—
Group 2 Grades C90 and T95	Full-length standard tubing or casing from one or more heats		Label 1: ≤ 4-1/2: 200 Label 1: > 4-1/2: 100	1	—
	Thick-wall mechanical tube or bar stock from a single heat		1	1 <sup>b</sup>	—
	Heat-treated in blanks or individual lengths or hot forgings	Batch heat treatment	Label 1: < 9-5/8: 50 <sup>c</sup> Label 1: ≥ 9-5/8: 30 <sup>c</sup>	1	—
		Heat-treated in sequential loads or continuous heat treatment	Label 1: < 9-5/8: 50 <sup>c</sup> Label 1: ≥ 9-5/8: 30 <sup>c</sup>	1	—
Group 4 Grade Q125	Full-length standard tubing or casing from one or more heats		In accordance with 10.2.3	3 <sup>b</sup>	—
	Thick-wall mechanical tube or bar stock from a single heat		1	1 <sup>b</sup>	—
	Heat-treated in blanks or individual lengths or hot forgings	Batch heat treatment	Label 1: < 9-5/8: 50 <sup>c</sup> Label 1: ≥ 9-5/8: 30 <sup>c</sup>	1	—
		Heat-treated in sequential loads or continuous heat treatment	Label 1: < 9-5/8: 50 <sup>c</sup> Label 1: ≥ 9-5/8: 30 <sup>c</sup>	1	—

<sup>a</sup> Accessories shall be made from seamless material or hot forgings.

<sup>b</sup> Approximately 50 % from each end.

<sup>c</sup> Each lot shall be from the same heat of steel for Grades L80 9Cr, L80 13Cr, C90, T95 and Q125. See 10.2.3.

**Table E.43 — Frequency of hardness testing**

Grade	Product		Number of tests per lot	Maximum number of pieces in a lot	Type of test	Location	
1	2		3	4	5	6	
Grades M65, L80	Pipe, coupling stock, thick-wall mechanical tubes, bar stock	Label 1: ≤ 4-1/2	2 <sup>a</sup>	200 <sup>b, c</sup>	Through-wall, 1 quadrant	Pipe, tube or stock body tensile test	
		Label 1: > 4-1/2	2 <sup>a</sup>	100 <sup>b, c</sup>	Through-wall, 1 quadrant	Pipe, tube or stock body tensile test	
	Coupling blanks or hot forgings		2 <sup>a</sup>	Heat-treat lot or 400 couplings <sup>b, c</sup>	Through-wall, 1 quadrant	Coupling blank tensile test	
	Pup joints and accessories (heat-treated in blank or individual lengths)	Batch heat treatment (method a, 10.2.3)	2 <sup>a</sup>	100 pup joints or 400 accessories <sup>b, c</sup>	Through-wall, 1 quadrant	Pup-joint or accessory tensile test	
		Heat-treated in sequential loads (method b, 10.2.3)	2 <sup>a</sup>	Lot (see 10.2) <sup>b, c</sup>	Through-wall, 1 quadrant	Pup-joint or accessory tensile test	
Continuous heat treatment (method c, 10.2.3)		2 <sup>a</sup>	Lot (see 10.2) <sup>b, c</sup>	Through-wall, 1 quadrant	Pup-joint or accessory tensile test		
Grades C90, T95	As-quenched product		1	Each production run or heat-treatment practice	Through-wall, 4 quadrants	Design area of greatest thickness	
	Non-upset pipe		1	Each length	Through-wall, 1 quadrant	Approx. 50 % from each end	
	Upset pipe			1	Each length	Surface – HRC or HBW	Pipe body and one upset <sup>d</sup>
				1	20 <sup>c</sup>	Through-wall, 4 quadrants	One upset
				1	Label 1: ≤ 4-1/2: 200 Label 1: > 4-1/2: 100	Through-wall, 4 quadrants	Pipe body tensile test
	Couplings, pup joints and accessories	Tube length heat treatment	2	Each length	Through-wall, 4 quadrants	One from each end	
		Individual heat treatment	1	Each piece	Surface – HRC or HBW	Each piece	
1			Label 1: < 9-5/8: 50 <sup>c</sup> Label 1: ≥ 9-5/8: 30 <sup>c</sup>	Through-wall, 4 quadrants	From a piece with the highest surface hardness number in the lot		
Grade Q125	Casing		3	Lot (see 10.2) <sup>b, c</sup>	Through-wall, 1 quadrant	Pipe body	
	Couplings, pup joints and accessories	Tube length heat treatment	1	Each length	Through-wall, 1 quadrant	Approx. 50 % from each end	
		Individual heat treatment	1	Each piece	Surface – HRC or HBW	Each piece	
			1	Label 1: < 9-5/8: 50 <sup>c</sup> Label 1: ≥ 9-5/8: 30 <sup>c</sup>	Through-wall, 1 quadrant	Randomly selected piece	
<sup>a</sup>	Lots which include more than one heat shall have two hardness tests from each heat.						
<sup>b</sup>	The lengths tested shall be selected randomly and represent the start and end of the heat treatment cycle.						
<sup>c</sup>	Each lot shall be from the same heat of steel for Grades L80 9Cr, L80 13Cr, C90, T95 and Q125.						
<sup>d</sup>	One upset, approximately 50 % from each end if both ends are upset.						



**Table E.44 — Frequency of flattening tests**

Casing and tubing					
Group	Type of heat treatment		Number of tests		
1	2	3	4		
1, 2 and 3	Non-full body		As described in footnote a		
	Full body	≤ Label 1: 4-1/2	Same as non-full body heat-treated or 1 per lot of 100 lengths or less		
		> Label 1: 4-1/2 <sup>b</sup>	Same as non-full body heat-treated or 1 per lot of 20 lengths or less		
4	All		1 on each end of each length of pipe [see A.5 (SR11)]		
Pup joints					
Group	Source of pup joint		Maximum number of pieces in a lot	Number of tests	
				per lot	per heat
1	2	3	4	5	6
1, 2 and 3	Treated separately	Batch heat-treated	100 pup joints	1	1
		Continuously heat-treated	—		
	Manufactured from EW pipe	≤ Label 1: 4-1/2	200 lengths		
		> Label 1: 4-1/2 <sup>b</sup>	100 lengths		
4	All		1 on each end of each length of pipe		

<sup>a</sup> The leading end of the first pipe of each coil shall have two test specimens flattened: one in the 90° position and one in the 0° position. Two test specimens shall be flattened from an intermediate pipe of each coil: one in the 90° position and one in the 0° position. The trailing end of the last pipe of each coil shall have two test specimens flattened: one in the 90° position and one in the 0° position. When a weld stop condition occurs during production of a multiple length, flattening tests with the weld at the 90° position and 0° position shall be made from the crop end resulting from each side of the weld stop, and may be substituted for the intermediate flattening tests. 90° position: the weld is positioned at 3 o'clock or at 9 o'clock. 0° position: the weld is positioned at 6 o'clock or at 12 o'clock.

<sup>b</sup> Includes casing used as tubing.

Table E.45 — Hydrostatic test pressure for Grade H40 casing

Label 1	Label 2	Test pressure psi		
		Plain end	Round thread <sup>a</sup>	
			STC	LC
1	2	3	4	5
4-1/2	9.50	2 900	2 900	—
5-1/2	14.00	2 800	2 800	—
6-5/8	20.00	2 800	2 800	—
7	17.00	2 100	2 100	—
7	20.00	2 500	2 500	—
7-5/8	24.00	2 500	2 500	—
8-5/8	28.00	2 300	2 300	—
8-5/8	32.00	2 600	2 600	—
9-5/8	32.30	2 100	2 100	—
9-5/8	36.00	2 300	2 300	—
10-3/4	32.75	1 200 (1 700)	1 200 (1 700)	— —
10-3/4	40.50	1 600 (2 100)	1 600 (2 100)	— —
11-3/4	42.00	1 400 (1 800)	1 400 (1 800)	— —
13-3/8	48.00	1 200 (1 600)	1 200 (1 600)	— —
16	65.00	1 100 (1 500)	1 100 (1 500)	— —
18-5/8	87.50	1 100 (1 500)	1 100 (1 500)	— —
20	94.00	1 100 (1 400)	1 100 (1 400)	1 100 (1 400)

NOTE Alternative test pressures are given in parentheses.

<sup>a</sup> The test pressures shown are for threaded and coupled pipe furnished with H40, J55 or K55 couplings.

**Table E.46 — Hydrostatic test pressure for Grades J55 and K55 casing**

Labels		Test pressure psi							XC
		Plain end	Round thread		Buttress thread				
1	2		STC	LC	Regular coupling		Special-clearance coupling		
					J55 K55	L80	J55 K55	L80	
1	2	3	4	5	6	7	8	9	10
3-1/2 <sup>a</sup>	9.92	7 300	—	—	—	—	—	—	—
4 <sup>a</sup>	11.25	6 300	—	—	—	—	—	—	—
4-1/2	9.50	4 000	4 000	—	—	—	—	—	—
4-1/2	10.50	4 400	4 400	—	4 400	4 400	4 400	4 400	—
4-1/2	11.60	4 900	4 900	4 900	4 900	4 900	4 400	4 900	—
4-1/2 <sup>a</sup>	13.05	5 700	—	—	—	—	—	—	—
5	11.50	3 900	3 900	—	—	—	—	—	—
5	13.00	4 500	4 500	4 500	4 500	4 500	4 100	4 500	—
5	15.00	5 200	5 200	5 200	5 200	5 200	4 100	5 200	5 200
5 <sup>a</sup>	17.95	6 400	—	—	—	—	—	—	—
5-1/2	14.00	3 900	3 900	—	—	—	—	—	—
5-1/2	15.50	4 400	4 400	4 400	4 400	4 400	3 800	4 400	4 400
5-1/2	17.00	4 900	4 900	4 900	4 900	4 900	3 800	4 900	4 900
5-1/2 <sup>a</sup>	19.83	5 800	—	—	—	—	—	—	—
6-5/8	20.00	3 800	3 800	3 800	3 800	3 800	3 200	3 800	—
6-5/8	24.00	4 700	4 700	4 700	4 700	4 700	3 200	4 700	4 700
6-5/8 <sup>a</sup>	27.67	5 500	—	—	—	—	—	—	—
7	20.00	3 400	3 400	—	—	—	—	—	—
7	23.00	4 000	4 000	4 000	4 000	4 000	3 200	4 000	4 000
7	26.00	4 600	4 600	4 600	4 600	4 600	3 200	4 600	4 600
7-5/8	26.40	3 800	3 800	3 800	3 800	3 800	3 600	3 800	3 800
8-5/8	24.00	2 700	2 700	—	—	—	—	—	—
8-5/8	32.00	3 600	3 600	3 600	3 600	3 600	3 200	3 600	3 600
8-5/8	36.00	4 100	4 100	4 100	4 100	4 100	3 200	4 100	4 100
9-5/8	36.00	3 200	3 200	3 200	3 200	3 200	2 900	3 200	—
9-5/8	40.00	3 600	3 600	3 600	3 600	3 600	2 900	3 600	3 600
10-3/4	40.50	2 100 (2 900)	2 100 (2 900)	—	2 100 (2 900)	2 100 (2 900)	2 100 (2 600)	2 100 (2 900)	—
10-3/4	45.50	2 500 (3 300)	2 500 (3 300)	—	2 500 (3 300)	2 500 (3 300)	2 500 (2 600)	2 500 (3 300)	2 500 (3 300)
10-3/4	51.00	2 800 (3 700)	2 800 (3 700)	—	2 800 (3 700)	2 800 (3 700)	2 600 (2 600)	2 800 (3 700)	2 800 (3 700)
11-3/4	47.00	2 100 (2 800)	2 100 (2 800)	—	2 100 (2 800)	2 100 (2 800)	—	—	—
11-3/4	54.00	2 400 (3 300)	2 400 (3 300)	—	2 400 (3 300)	2 400 (3 300)	—	—	—
11-3/4	60.00	2 700 (3 700)	2 700 (3 700)	—	2 700 (3 700)	2 700 (3 700)	—	—	—
13-3/8	54.50	1 900 (2 500)	1 900 (2 500)	—	1 900 (2 500)	1 900 (2 500)	—	—	—
13-3/8	61.00	2 100 (2 800)	2 100 (2 800)	—	2 100 (2 800)	2 100 (2 800)	—	—	—
13-3/8	68.00	2 400 (3 200)	2 400 (3 200)	—	2 400 (3 200)	2 400 (3 200)	—	—	—
16	75.00	1 800 (2 400)	1 800 (2 400)	—	1 800 (2 400)	1 800 (2 400)	—	—	—
16	84.00	2 000 (2 700)	2 000 (2 700)	—	2 000 (2 700)	2 000 (2 700)	—	—	—
16	109.00	2 700 (3 600)	—	—	—	—	—	—	—
18-5/8	87.50	1 500 (2 100)	1 500 (2 100)	—	1 500 (2 100)	1 500 (2 100)	—	—	—
20	94.00	1 400 (1 900)	1 400 (1 900)	1 400 (1 900)	1 400 (1 900)	1 400 (1 900)	—	—	—
20	106.50	1 600 (2 200)	1 600 (2 200)	1 600 (2 200)	1 600 (2 200)	1 600 (2 200)	—	—	—
20	133.00	2 100 (2 800)	2 100 (2 400)	2 100 (2 400)	2 100 (2 300)	2 100 (2 300)	—	—	—

NOTE Alternative test pressures are given in parentheses.

<sup>a</sup> Used as plain-end casing liner.

**Table E.47 — Hydrostatic test pressure for Grade M65 casing**

Labels		Test pressure psi				
		Plain end	Round thread <sup>a</sup>		Buttress thread <sup>a</sup>	
1	2		STC	LC	Regular coupling	Special-clearance coupling
1	2	3	4	5	6	7
4-1/2	9.50	4 700	4 700	—	—	—
4-1/2	10.50	5 200	5 200	—	5 200	5 200
4-1/2	11.60	5 800	5 800	5 800	5 800	5 800
4-1/2	13.50	6 700	—	6 700	6 700	6 400
5	11.50	4 600	4 600	—	—	—
5	13.00	5 300	5 300	5 300	5 300	5 300
5	15.00	6 200	—	6 200	6 200	6 000
5	18.00	7 500	—	7 500	7 500	6 000
5	21.40	9 100	—	8 700	7 900	6 000
5-1/2	14.00	4 600	4 600	—	—	—
5-1/2	15.50	5 200	5 200	5 200	5 200	5 200
5-1/2	17.00	5 700	—	5 700	5 700	5 500
5-1/2	20.00	6 800	—	6 800	6 800	5 500
5-1/2	23.00	7 800	—	7 800	7 200	5 500
6-5/8	20.00	4 500	4 500	4 500	4 500	4 500
6-5/8	24.00	5 500	—	5 500	5 500	4 700
6-5/8	28.00	6 500	—	6 500	6 500	4 700
7	20.00	4 000	4 000	—	—	—
7	23.00	4 700	—	4 700	4 700	4 600
7	26.00	5 400	—	5 400	5 400	4 600
7	29.00	6 100	—	6 100	6 100	4 600
7	32.00	6 700	—	6 700	6 700	4 600
7-5/8	26.40	4 500	4 500	4 500	4 500	4 500
7-5/8	29.70	5 100	—	5 100	5 100	5 100
7-5/8	33.70	5 900	—	5 900	5 900	5 200
8-5/8	24.00	3 200	3 200	—	—	—
8-5/8	28.00	3 700	3 700	—	—	—
8-5/8	32.00	4 200	4 200	4 200	4 200	4 200
8-5/8	36.00	4 800	4 800	4 800	4 800	4 700
8-5/8	40.00	5 400	—	5 400	5 400	4 700
9-5/8	36.00	3 800	3 800	3 800	3 800	3 800
9-5/8	40.00	4 300	4 300	4 300	4 300	4 300
9-5/8	43.50	4 700	—	4 700	4 700	4 300
9-5/8	47.00	5 100	—	5 100	5 100	4 300
10-3/4	40.50	3 400	3 400	—	3 400	3 400
10-3/4	45.50	3 900	3 900	—	3 900	3 800
10-3/4	51.00	4 400	4 400	—	4 400	3 800
10-3/4	55.50	4 800	4 800	—	4 800	3 800
11-3/4	47.00	3 300	3 300	—	3 300	—
11-3/4	54.00	3 900	3 900	—	3 900	—
11-3/4	60.00	4 300	4 300	—	4 300	—
13-3/8	54.50	3 000	3 000	—	3 000	—
13-3/8	61.00	3 300	3 300	—	3 300	—
13-3/8	68.00	3 700	3 700	—	3 700	—
16	75.00	2 800	2 800	—	2 800	—
16	84.00	3 200	3 200	—	3 200	—
18-5/8	87.50	2 400	2 400	—	2 400	—
20	94.00	2 300	2 100	2 100	2 300	—
20	106.50	2 600	2 100	2 100	2 300	—

<sup>a</sup> Threaded and coupled Grade M65 casing shall be furnished with Grade L80 Type 1 couplings.

**Table E.48 — Hydrostatic test pressure for Grade L80 casing**

Labels		Test pressure psi					
		Plain end	Round thread		Buttress thread		XC
1	2		STC	LC	Regular coupling	Special-clearance coupling	
1	2	3	4	5	6	7	8
4-1/2	11.60	7 100	—	7 100	7 100	6 400	—
4-1/2	13.50	8 200	—	8 200	7 800	6 400	—
5	15.00	7 600	—	7 600	7 600	6 000	7 600
5	18.00	9 300	—	8 700	7 900	6 000	9 300
5	21.40	10 000	—	8 700	7 900	6 000	—
5	23.20	10 000	—	8 700	7 900	6 000	—
5	24.10	10 000	—	8 700	7 900	6 000	—
5-1/2	17.00	7 100	—	7 100	7 100	5 500	7 100
5-1/2	20.00	8 400	—	7 900	7 200	5 500	8 400
5-1/2	23.00	9 700	—	7 900	7 200	5 500	9 700
6-5/8	24.00	6 800	—	6 800	6 800	4 700	6 800
6-5/8	28.00	8 100	—	8 100	7 900	4 700	8 100
6-5/8	32.00	9 200	—	8 500	7 900	4 700	9 200
7	23.00	5 800	—	5 800	5 800	4 600	5 800
7	26.00	6 600	—	6 600	6 600	4 600	6 600
7	29.00	7 500	—	7 400	6 800	4 600	7 500
7	32.00	8 300	—	7 400	6 800	4 600	8 300
7	35.00	9 100	—	7 400	6 800	4 600	9 100
7	38.00	9 900	—	7 400	6 800	4 600	9 900
7-5/8	26.40	5 500	—	5 500	5 500	5 200	5 500
7-5/8	29.70	6 300	—	6 300	6 300	5 200	6 300
7-5/8	33.70	7 200	—	7 200	7 200	5 200	7 200
7-5/8	39.00	8 400	—	8 400	7 800	5 200	8 400
7-5/8	42.80	9 400	—	8 400	7 800	5 200	—
7-5/8	45.30	10 000	—	8 400	7 800	5 200	—
7-5/8	47.10	10 000	—	8 400	7 800	5 200	—
7-3/4	46.10	9 800	—	—	—	—	—
8-5/8	36.00	5 900	—	5 900	5 900	4 700	5 900
8-5/8	40.00	6 700	—	6 700	6 700	4 700	6 700
8-5/8	44.00	7 400	—	7 400	7 400	4 700	7 400
8-5/8	49.00	8 300	—	8 300	7 800	4 700	8 300
9-5/8	40.00	5 300	—	5 300	5 300	4 300	5 300
9-5/8	43.50	5 800	—	5 800	5 800	4 300	5 800
9-5/8	47.00	6 300	—	6 300	6 300	4 300	6 300
9-5/8	53.50	7 200	—	7 200	7 100	4 300	7 200
9-5/8	58.40	7 900	—	7 700	7 100	4 300	—
10-3/4	51.00	5 400	5 400	—	5 400	3 800	5 400
10-3/4	55.50	5 900	5 900	—	5 900	3 800	5 900
11-3/4	60.00	5 300	5 300	—	5 300	—	—
11-3/4	65.00	5 800	—	—	—	—	—
11-3/4	71.00	6 300	—	—	—	—	—
13-3/8	68.00	4 600	4 600	—	4 600	—	—
13-3/8	72.00	4 900	4 600	—	4 900	—	—
16	109.00	5 200	—	—	—	—	—

**Table E.49 — Hydrostatic test pressure for Grade N80 Type 1 and N80Q casing**

Labels		Test pressure psi							XC
		Plain end	Round thread		Buttress thread				
1	2		3	STC	LC	Regular coupling		Special-clearance coupling	
		N80				P110	N80	P110	
1	2	3	4	5	6	7	8	9	10
4-1/2	11.60	7 100	—	7 100	7 100	7 100	6 400	7 100	—
4-1/2	13.50	8 200	—	8 200	7 800	8 200	6 400	8 200	—
5	15.00	7 600	—	7 600	7 600	7 600	6 000	7 600	7 600
5	18.00	9 300	—	8 700	7 900	9 300	6 000	8 200	9 300
5	21.40	10 000	—	8 700	7 900	10 000	6 000	8 200	—
5	23.20	10 000	—	8 700	7 900	10 000	6 000	8 200	—
5	24.10	10 000	—	8 700	7 900	10 000	6 000	8 200	—
5-1/2	17.00	7 100	—	7 100	7 100	7 100	5 500	7 100	7 100
5-1/2	20.00	8 400	—	7 900	7 200	8 400	5 500	7 600	8 400
5-1/2	23.00	9 700	—	7 900	7 200	9 700	5 500	7 600	9 700
6-5/8	24.00	6 800	—	6 800	6 800	6 800	4 700	6 500	6 800
6-5/8	28.00	8 100	—	8 100	7 900	8 100	4 700	6 500	8 100
6-5/8	32.00	9 200	—	8 500	7 900	9 200	4 700	6 500	9 200
7	23.00	5 800	—	5 800	5 800	5 800	4 600	5 800	5 800
7	26.00	6 600	—	6 600	6 600	6 600	4 600	6 300	6 600
7	29.00	7 500	—	7 400	6 800	7 500	4 600	6 300	7 500
7	32.00	8 300	—	7 400	6 800	8 300	4 600	6 300	8 300
7	35.00	9 100	—	7 400	6 800	9 100	4 600	6 300	9 100
7	38.00	9 900	—	7 400	6 800	9 300	4 600	6 300	9 900
7-5/8	26.40	5 500	—	5 500	5 500	5 500	5 200	5 500	5 500
7-5/8	29.70	6 300	—	6 300	6 300	6 300	5 200	6 300	6 300
7-5/8	33.70	7 200	—	7 200	7 200	7 200	5 200	7 200	7 200
7-5/8	39.00	8 400	—	8 400	7 800	8 400	5 200	7 200	8 400
7-5/8	42.80	9 400	—	8 400	7 800	9 400	5 200	7 200	—
7-5/8	45.30	10 000	—	8 400	7 800	10 000	5 200	7 200	—
7-5/8	47.10	10 000	—	8 400	7 800	10 000	5 200	7 200	—
7-3/4	46.10	9 800	—	—	—	—	—	—	—
8-5/8	36.00	5 900	—	5 900	5 900	5 900	4 700	5 900	5 900
8-5/8	40.00	6 700	—	6 700	6 700	6 700	4 700	6 300	6 700
8-5/8	44.00	7 400	—	7 400	7 400	7 400	4 700	6 300	7 400
8-5/8	49.00	8 300	—	8 300	7 800	8 300	4 700	6 300	8 300
9-5/8	40.00	5 300	—	5 300	5 300	5 300	4 300	5 100	5 300
9-5/8	43.50	5 800	—	5 800	5 800	5 800	4 300	5 100	5 800
9-5/8	47.00	6 300	—	6 300	6 300	6 300	4 300	5 100	6 300
9-5/8	53.50	7 200	—	7 200	7 100	7 200	4 300	5 100	7 200
9-5/8	58.40	7 900	—	7 700	7 100	7 900	4 300	5 100	—
10-3/4	51.00	5 400	5 400	—	5 400	5 400	3 800	4 100	5 400
10-3/4	55.50	5 900	5 900	—	5 900	5 900	3 800	4 100	5 900
11-3/4	60.00	5 300	5 300	—	5 300	5 300	—	—	—
11-3/4	65.00	5 800	—	—	—	—	—	—	—
11-3/4	71.00	6 300	—	—	—	—	—	—	—
13-3/8	68.00	4 600	4 600	—	4 600	4 600	—	—	—
13-3/8	72.00	4 900	4 600	—	4 900	4 900	—	—	—
16	109.00	5 200	—	—	—	—	—	—	—

**Table E.50 — Hydrostatic test pressure for Grade C90 casing**

Labels		Test pressure psi					
		Plain end	Round thread		Buttress thread		XC
1	2		STC	LC	Regular coupling	Special-clearance coupling	
1	2	3	4	5	6	7	8
4-1/2	11.60	8 000	—	8 000	8 000	7 200	—
4-1/2	13.50	9 300	—	9 300	8 800	7 200	—
5	15.00	8 500	—	8 500	8 500	6 700	8 500
5	18.00	10 000	—	9 700	8900	6 700	10 000
5	21.40	10 000	—	9 700	8 900	6 700	—
5	23.20	10 000	—	9 700	8 900	6 700	—
5	24.10	10 000	—	9 700	8 900	6 700	—
5-1/2	17.00	8 000	—	8 000	8 000	6 200	8 000
5-1/2	20.00	9 500	—	8 900	8 100	6 200	9 500
5-1/2	23.00	10 000	—	8 900	8 100	6 200	10 000
5-1/2	26.80	10 000	—	—	—	—	—
5-1/2	29.70	10 000	—	—	—	—	—
5-1/2	32.60	10 000	—	—	—	—	—
5-1/2	35.30	10 000	—	—	—	—	—
5-1/2	38.00	10 000	—	—	—	—	—
5-1/2	40.50	10 000	—	—	—	—	—
5-1/2	43.10	10 000	—	—	—	—	—
6-5/8	24.00	7700	—	7 700	7 700	5 300	7 700
6-5/8	28.00	9100	—	9 100	8 800	5 300	9 100
6-5/8	32.00	10 000	—	9 600	8 800	5 300	10 000
7	23.00	6 500	—	6 500	6 500	5 200	6 500
7	26.00	7 400	—	7 400	7 400	5 200	7 400
7	29.00	8 400	—	8 300	7 600	5 200	8 400
7	32.00	9 300	—	8 300	7 600	5 200	9 300
7	35.00	10 000	—	8 300	7 600	5 200	10 000
7	38.00	10 000	—	8 300	7600	5 200	10 000
7	42.70	10 000	—	—	—	—	—
7	46.40	10 000	—	—	—	—	—
7	50.10	10 000	—	—	—	—	—
7	53.60	10 000	—	—	—	—	—
7	57.10	10 000	—	—	—	—	—
7-5/8	26.40	6 200	—	6 200	6 200	5 900	6 200
7-5/8	29.70	7 100	—	7 100	7 100	5 900	7 100
7-5/8	33.70	8 100	—	8 100	8 100	5 900	8 100
7-5/8	39.00	9 400	—	9 400	8 800	5 900	9 400
7-5/8	42.80	10 000	—	9 400	8 800	5 900	—
7-5/8	45.30	10 000	—	9 400	8 800	5 900	—
7-5/8	47.10	10 000	—	9 400	8 800	5 900	—
7-5/8	51.20	10 000	—	—	—	—	—
7-5/8	55.30	10 000	—	—	—	—	—
7-3/4	46.10	10 000	—	—	—	—	—
8-5/8	36.00	6 700	—	6 700	6 700	5 300	6 700
8-5/8	40.00	7 500	—	7 500	7 500	5 300	7 500
8-5/8	44.00	8 300	—	8 300	8 300	5 300	8 300
8-5/8	49.00	9 300	—	9 300	8 800	5 300	9 300

Table E.50 (continued)

Labels		Test pressure psi					XC
		Plain end	Round thread		Buttress thread		
1	2		STC	LC	Regular coupling	Special-clearance coupling	
1	2	3	4	5	6	7	8
9-5/8	40.00	5 900	—	5 900	5 900	4 800	5 900
9-5/8	43.50	6 500	—	6 500	6 500	4 800	6 500
9-5/8	47.00	7 100	—	7 100	7 100	4 800	7 100
9-5/8	53.50	8 200	—	8 200	7 900	4 800	8 200
9-5/8	58.40	8 900	—	8 500	7 900	4 800	—
9-5/8	59.40	9 100	—	—	—	—	—
9-5/8	64.90	10 000	—	—	—	—	—
9-5/8	70.30	10 000	—	—	—	—	—
9-5/8	75.60	10 000	—	—	—	—	—
10-3/4	51.00	6 000	6 000	—	6 000	4 100	6 000
10-3/4	55.50	6 600	6 600	—	6 600	4 100	6 600
10-3/4	60.70	7 300	6 900	—	7 200	4 100	7 300
10-3/4	65.70	8 000	6 900	—	7 200	4 100	—
10-3/4	73.20	9 000	—	—	—	—	—
10-3/4	79.20	9 800	—	—	—	—	—
10-3/4	85.30	10 000	—	—	—	—	—
11-3/4	60.00	6 000	5 800	—	6 000	—	—
11-3/4	65.00	6 500	—	—	—	—	—
11-3/4	71.00	7 100	—	—	—	—	—
13-3/8	68.00	5 200	4 600	—	4 900	—	—
13-3/8	72.00	5 500	4 600	—	4 900	—	—



**Table E.51 — Hydrostatic test pressure for Grade C95 casing**

Labels		Test pressure psi					
		Plain end	Round thread		Buttress thread		XC
1	2		STC	LC	Regular coupling	Special-clearance coupling	
1	2	3	4	5	6	7	8
4-1/2	11.60	8 400	—	8 400	8 400	7 600	—
4-1/2	13.50	9 800	—	9 800	9 300	7 600	—
5	15.00	9 000	—	9 000	9 000	7 100	9 000
5	18.00	10 000	—	10 000	9 400	7 100	10 000
5	21.40	10 000	—	10 000	9 400	7 100	—
5	23.20	10 000	—	10 000	9 400	7 100	—
5	24.10	10 000	—	10 000	9 400	7 100	—
5-1/2	17.00	8 400	—	8 400	8 400	6 500	8 400
5-1/2	20.00	10 000	—	9 400	8 500	6 500	10 000
5-1/2	23.00	10 000	—	9 400	8 500	6 500	10 000
6-5/8	24.00	8 100	—	8 100	8 100	5 600	8 100
6-5/8	28.00	9 600	—	9 600	9 300	5 600	9 600
6-5/8	32.00	10 000	—	10 000	9 300	5 600	10 000
7	23.00	6 900	—	6 900	6 900	5 500	6 900
7	26.00	7 900	—	7 900	7 900	5 500	7 900
7	29.00	8 900	—	8 800	8 000	5 500	8 900
7	32.00	9 800	—	8 800	8 000	5 500	9 800
7	35.00	10 000	—	8 800	8 000	5 500	10 000
7	38.00	10 000	—	8 800	8 000	5 500	10 000
7-5/8	26.40	6 500	—	6 500	6 500	6 200	6 500
7-5/8	29.70	7 500	—	7 500	7 500	6 200	7 500
7-5/8	33.70	8 600	—	8 600	8 600	6 200	8 600
7-5/8	39.00	10 000	—	10 000	9 300	6 200	10 000
7-5/8	42.80	10 000	—	10 000	9 300	6 200	—
7-5/8	45.30	10 000	—	10 000	9 300	6 200	—
7-5/8	47.10	10 000	—	10 000	9 300	6 200	—
7-3/4	46.10	10 000	—	—	—	—	—
8-5/8	36.00	7 000	—	7 000	7 000	5 600	7 000
8-5/8	40.00	7 900	—	7 900	7 900	5 600	7 900
8-5/8	44.00	8 800	—	8 800	8 800	5 600	8 800
8-5/8	49.00	9 800	—	9 800	9 300	5 600	9 800
9-5/8	40.00	6 200	—	6 200	6 200	5 100	6 200
9-5/8	43.50	6 900	—	6 900	6 900	5 100	6 900
9-5/8	47.00	7 500	—	7 500	7 500	5 100	7 500
9-5/8	53.50	8 600	—	8 500	8 400	5 100	8 600
9-5/8	58.40	9 400	—	8 500	8 400	5 100	—
10-3/4	51.00	6 400	6 400	—	6 400	4 100	6 400
10-3/4	55.50	7 000	6 900	—	7 000	4 100	7 000
11-3/4	60.00	6 300	5 800	—	6 300	—	—
11-3/4	65.00	6 900	—	—	—	—	—
11-3/4	71.00	7 500	—	—	—	—	—
13-3/8	68.00	5 500	4 600	—	4 900	—	—
13-3/8	72.00	5 800	4 600	—	4 900	—	—
16	109.00	6 200	—	—	—	—	—

**Table E.52 — Hydrostatic test pressure for Grade T95 casing**

Labels		Test pressure psi					
		Plain end	Round thread		Buttress thread		XC
1	2		STC	LC	Regular coupling	Special-clearance coupling	
1	2	3	4	5	6	7	8
4-1/2	11.60	8 400	—	8 400	8 400	7 600	—
4-1/2	13.50	9 800	—	9 800	9 300	7 600	—
5	15.00	9 000	—	9 000	9 000	7 100	9 000
5	18.00	10 000	—	10 000	9 400	7 100	10 000
5	21.40	10 000	—	10 000	9 400	7 100	—
5	23.20	10 000	—	10 000	9 400	7 100	—
5	24.10	10 000	—	10 000	9 400	7 100	—
5-1/2	17.00	8 400	—	8 400	8 400	6 500	8 400
5-1/2	20.00	10 000	—	9 400	8 500	6 500	10 000
5-1/2	23.00	10 000	—	9 400	8 500	6 500	10 000
5-1/2	26.80	10 000	—	—	—	—	—
5-1/2	29.70	10 000	—	—	—	—	—
5-1/2	32.60	10 000	—	—	—	—	—
5-1/2	35.30	10 000	—	—	—	—	—
5-1/2	38.00	10 000	—	—	—	—	—
5-1/2	40.50	10 000	—	—	—	—	—
5-1/2	43.10	10 000	—	—	—	—	—
6-5/8	24.00	8 100	—	8 100	8 100	5 600	8 100
6-5/8	28.00	9 600	—	9 600	9 300	5 600	9 600
6-5/8	32.00	10 000	—	10 000	9 300	5 600	10 000
7	23.00	6 900	—	6 900	6 900	5 500	6 900
7	26.00	7 900	—	7 900	7 900	5 500	7 900
7	29.00	8 900	—	8 800	8 000	5 500	8 800
7	32.00	9 800	—	8 800	8 000	5 500	9 800
7	35.00	10 000	—	8 800	8 000	5 500	10 000
7	38.00	10 000	—	8 800	8 000	5 500	10 000
7	42.70	10 000	—	—	—	—	—
7	46.40	10 000	—	—	—	—	—
7	50.10	10 000	—	—	—	—	—
7	53.60	10 000	—	—	—	—	—
7	57.10	10 000	—	—	—	—	—
7-5/8	26.40	6 500	—	6 500	6 500	6 200	6 500
7-5/8	29.70	7 500	—	7 500	7 500	6 200	7 500
7-5/8	33.70	8 600	—	8 600	8 600	6 200	8 600
7-5/8	39.00	10 000	—	10 000	9 300	6 200	10 000
7-5/8	42.80	10 000	—	10 000	9 300	6 200	—
7-5/8	45.30	10 000	—	10 000	9 300	6 200	—
7-5/8	47.10	10 000	—	10 000	9 300	6 200	—
7-5/8	51.20	10 000	—	—	—	—	—
7-5/8	55.30	10 000	—	—	—	—	—
7-3/4	46.10	10 000	—	—	—	—	—
8-5/8	36.00	7 000	—	7 000	7 000	5 600	7 000
8-5/8	40.00	7 900	—	7 900	7 900	5 600	7 900
8-5/8	44.00	8 800	—	8 800	8 800	5 600	8 800
8-5/8	49.00	9 800	—	9 800	9 300	5 600	9 800

Table E.52 (continued)

Labels		Test pressure psi					XC
		Plain end	Round thread		Buttress thread		
1	2		STC	LC	Regular coupling	Special-clearance coupling	
1	2	3	4	5	6	7	8
9-5/8	40.00	6 200	—	6 200	6 200	5 100	6 200
9-5/8	43.50	6 900	—	6 900	6 900	5 100	6 900
9-5/8	47.00	7 500	—	7 500	7 500	5 100	7 500
9-5/8	53.50	8 600	—	8 500	8 400	5 100	8 600
9-5/8	58.40	9 400	—	8 500	8 400	5 100	—
9-5/8	59.40	9 600	—	—	—	—	—
9-5/8	64.90	10 000	—	—	—	—	—
9-5/8	70.30	10 000	—	—	—	—	—
9-5/8	75.60	10 000	—	—	—	—	—
10-3/4	51.00	6 400	6 400	—	6 400	4 100	6 400
10-3/4	55.50	7 000	6 900	—	7 000	4 100	7 000
10-3/4	60.70	7 700	6 900	—	7 500	4 100	7 600
10-3/4	65.70	8 400	6 900	—	7 500	4 100	—
10-3/4	73.20	9 500	—	—	—	—	—
10-3/4	79.20	10 000	—	—	—	—	—
10-3/4	85.30	10 000	—	—	—	—	—
11-3/4	60.00	6 300	5 800	—	6 300	—	—
11-3/4	65.00	6 900	—	—	—	—	—
11-3/4	71.00	7 500	—	—	—	—	—
13-3/8	68.00	5 500	4 600	—	4 900	—	—
13-3/8	72.00	5 800	4 600	—	4 900	—	—

**Table E.53 — Hydrostatic test pressure for Grade P110 casing**

Labels		Test pressure psi							
		Plain end	Round thread		Buttress thread				XC
			STC	LC	Regular coupling		Special-clearance coupling		
1	2				P110	Q125	P110	Q125	
1	2	3	4	5	6	7	8	9	10
4-1/2	11.60	9 800	—	9 800	9 800	9 800	8 800	9 800	—
4-1/2	13.50	10 000 (11 300)	—	10 000 (11 300)	10 000 (10 800)	10 000 (11 300)	8 800 (8 800)	10 000 (10 000)	—
4-1/2	15.10	10 000 (13 200)	—	10 000 (11 700)	10 000 (10 800)	10 000 (12 200)	8 800 (8 800)	10 000 (10 000)	—
5	15.00	10 000 (10 400)	—	10 000 (10 400)	10 000 (10 400)	10 000 (10 400)	8 200 (8 200)	9 300 (9 300)	10 000 (10 400)
5	18.00	10 000 (12 700)	—	10 000 (11 900)	10 000 (10 900)	10 000 (12 400)	8 200 (8 200)	9 300 (9 300)	10 000 (12 700)
5	21.40	10 000 (15 400)	—	10 000 (11 900)	10 000 (10 900)	10 000 (12 400)	8 200 (8 200)	9 300 (9 300)	—
5	23.20	10 000 (16 800)	—	10 000 (11 900)	10 000 (10 900)	10 000 (12 400)	8 200 (8 200)	9 300 (9 300)	—
5	24.10	10 000 (17 600)	—	10 000 (11 900)	10 000 (10 900)	10 000 (12 400)	8 200 (8 200)	9 300 (9 300)	—
5-1/2	17.00	9 700	—	9 700	9 700	9 700	7 600	8 600	9 700
5-1/2	20.00	10 000 (11 600)	—	10 000 (10 900)	9 900 (9 900)	10 000 (11 200)	7 600 (7 600)	8 600 (8 600)	10 000 (11 600)
5-1/2	23.00	10 000 (13 300)	—	10 000 (10 900)	9 900 (9 900)	10 000 (11 200)	7 600 (7 600)	8 600 (8 600)	10 000 (13 300)
6-5/8	24.00	9 400	—	9 400	9 400	9 400	6 500	7 400	9 400
6-5/8	28.00	10 000 (11 100)	—	10 000 (11 100)	10 000 (10 800)	10 000 (11 100)	6 500 (6 500)	7 400 (7 400)	10 000 (11 100)
6-5/8	32.00	10 000 (12 600)	—	10 000 (11 700)	10 000 (10 800)	10 000 (12 300)	6 500 (6 500)	7 400 (7 400)	10 000 (12 600)
7	26.00	9 100	—	9 100	9 100	9 100	6 300	7 200	9 100
7	29.00	10 000 (10 300)	—	9 500 (9 500)	9 300 (9 300)	10 000 (10 300)	6 300 (6 300)	7 200 (7 200)	10 000 (10 300)
7	32.00	10 000 (11 400)	—	9 500 (9 500)	9 300 (9 300)	10 000 (10 600)	6 300 (6 300)	7 200 (7 200)	10 000 (11 400)
7	35.00	10 000 (12 500)	—	9 500 (9 500)	9 300 (9 300)	10 000 (10 600)	6 300 (6 300)	7 200 (7 200)	10 000 (12 500)
7	38.00	10 000 (13 600)	—	9 500 (9 500)	9 300 (9 300)	10 000 (10 600)	6 300 (6 300)	7 200 (7 200)	10 000 (13 600)
7-5/8	29.70	8 700	—	8 700	8 700	8 700	7 200	8 000	8 700
7-5/8	33.70	9 900	—	9 900	9 900	9 900	7 200	8 000	9 900
7-5/8	39.00	10 000 (11 500)	—	10 000 (11 500)	10 000 (10 800)	10 000 (11 500)	7 200 (7 200)	8 000 (8 000)	10 000 (11 500)
7-5/8	42.80	10 000 (13 000)	—	10 000 (11 500)	10 000 (10 800)	10 000 (12 200)	7 200 (7 200)	8 000 (8 000)	—
7-5/8	45.30	10 000 (13 700)	—	10 000 (11 500)	10 000 (10 800)	10 000 (12 200)	7 200 (7 200)	8 000 (8 000)	—
7-5/8	47.10	10 000 (14 400)	—	10 000 (11 500)	10 000 (10 800)	10 000 (12 200)	7 200 (7 200)	8 000 (8 000)	—
7-3/4	46.10	10 000 (13 500)	—	—	—	—	—	—	—
8-5/8	40.00	9 200	—	9 200	9 200	9 200	6 300	6 300	9 200
8-5/8	44.00	10 000 (10 200)	—	10 000 (10 200)	10 000 (10 200)	10 000 (10 200)	6 300 (6 300)	6 300 (6 300)	10 000 (10 200)
8-5/8	49.00	10 000 (11 400)	—	10 000 (10 400)	10 000 (10 700)	10 000 (11 200)	6 300 (6 300)	6 300 (6 300)	10 000 (11 400)

See note at end of table.

**Table E.53 (continued)**

Labels		Test pressure psi							
		Plain end	Round thread		Buttress thread				XC
			STC	LC	Regular coupling		Special-clearance coupling		
1	2				P110	Q125	P110	Q125	
1	2	3	4	5	6	7	8	9	10
9-5/8	43.50	8 000	—	8 000	8 000	8 000	5 100	5 100	8 000
9-5/8	47.00	8 600	—	8 600	8 600	8 600	5 100	5 100	8 600
9-5/8	53.50	10 000	—	9 700	9 200	9 200	5 100	5 100	10 000
9-5/8	58.40	10 000 (10 900)	—	9 700 (9 700)	9 200 (9 200)	9 200 (9 200)	5 100 (5 100)	5 100 (5 100)	— —
10-3/4	51.00	7 400	7 400	—	7 400	7 400	4 200	4 200	7 400
10-3/4	55.50	8 100	7 900	—	7 400	7 400	4 200	4 200	8 100
10-3/4	60.70	8 900	7 900	—	7 400	7 400	4 200	4 200	8 900
10-3/4	65.70	9 700	7 900	—	7 400	7 400	4 200	4 200	—
11-3/4	60.00	7 300	6 700	—	6 300	6 300	—	—	—
11-3/4	65.00	8 000	—	—	—	—	—	—	—
11-3/4	71.00	8 700	—	—	—	—	—	—	—
13-3/8	68.00	6 300	5 200	—	4 900	4 900	—	—	—
13-3/8	72.00	6 800	5 200	—	4 900	4 900	—	—	—
16	109.00	7 200	—	—	—	—	—	—	—

NOTE Alternative test pressures are given in parentheses.

**Table E.54 — Hydrostatic test pressure for Grade Q125 casing**

Labels		Test pressure psi				
		Plain end	Round thread		Buttress thread, regular coupling	XC
1	2		STC	LC		
1	2	3	4	5	6	7
4-1/2	15.10	10 000 (15 000)	— —	10 000 (13 300)	10 000 (12 200)	— —
5	18.00	10 000 (14 500)	— —	10 000 (13 500)	10 000 (12 400)	10 000 (14 500)
5	21.40	10 000 (17 500)	— —	10 000 (13 500)	10 000 (12 400)	— —
5	23.20	10 000 (19 100)	— —	10 000 (13 500)	10 000 (12 400)	— —
5	24.10	10 000 (20 000)	— —	10 000 (13 500)	10 000 (12 400)	— —
5-1/2	23.00	10 000 (15 100)	— —	10 000 (12 300)	10 000 (11 200)	10 000 (15 100)
6-5/8	32.00	10 000 (14 300)	— —	10 000 (11 800)	10 000 (12 300)	10 000 (14 300)
7	35.00	10 000 (14 200)	— —	9 500 (9 500)	10 000 (10 600)	10 000 (14 200)
7	38.00	10 000 (15 400)	— —	9 500 (9 500)	10 000 (10 600)	10 000 (15 400)
7-5/8	39.00	10 000 (13 100)	— —	10 000 (11 800)	10 000 (12 200)	10 000 (13 100)
7-5/8	42.80	10 000 (14 700)	— —	10 000 (11 800)	10 000 (12 200)	— —
7-5/8	45.30	10 000 (15 600)	— —	10 000 (11 800)	10 000 (12 200)	— —
7-5/8	47.10	10 000 (16 400)	— —	10 000 (11 800)	10 000 (12 200)	— —
7-3/4	46.10	10 000 (15 400)	— —	— —	— —	— —
8-5/8	49.00	10 000 (12 900)	— —	10 000 (10 400)	10 000 (11 200)	10 000 (12 900)
9-5/8	47.00	9 800	—	9 700	9 200	9 800
9-5/8	53.50	10 000 (11 300)	— —	9 700 (9 700)	9 200 (9 200)	10 000 (11 300)
9-5/8	58.40	10 000 (12 400)	— —	9 700 (9 700)	9 200 (9 200)	— —
10-3/4	60.70	10 000 (10 100)	7 900 (7 900)	— —	7 400 (7 400)	10 000 (11 100)
10-3/4	65.70	10 000 (11 100)	7 900 (7 900)	— —	7 400 (7 400)	— —
11-3/4	60.00	8 300	6 700	—	6 300	—
11-3/4	65.00	9 100	—	—	—	—
11-3/4	71.00	9 900	—	—	—	—
13-3/8	72.00	7 700	5 200	—	4 900	—
16	109.00	8 200	—	—	—	—

NOTE Alternative test pressures are given in parentheses.

**Table E.55 — Hydrostatic test pressure for Grade H40 tubing**

Labels				Test pressure psi					
1	2			Plain end	Non- upset T&C	External upset			Integral joint
	NU T&C	EU T&C	IJ			Regular coupling	Special-clearance coupling		
							H40	J55	
1	2	3	4	5	6	7	8	9	10
1.050	1.14	1.20	—	6 900	6 900	6 900	—	—	—
1.050	1.48	1.54	—	9 400	—	7 500	—	—	—
1.315	1.70	1.80	1.72	6 500	6 500	6 500	—	—	5 800
1.315	2.19	2.24	—	8 700	—	8 200	—	—	—
1.660	2.09	—	2.10	4 800	—	—	—	—	4 600
1.660	2.30	2.40	2.33	5 400	5 400	5 400	—	—	4 600
1.660	3.03	3.07	—	7 400	—	6 500	—	—	—
1.900	2.40	—	2.40	4 200	—	—	—	—	4 100
1.900	2.75	2.90	2.76	4 900	4 900	4 900	—	—	4 100
1.900	3.65	3.73	—	6 700	—	6 000	—	—	—
2.063	3.24	—	3.25	4 800	—	—	—	—	4 100
2.063	4.50	—	—	7 000	—	—	—	—	—
2-3/8	4.00	—	—	4 500	4 500	—	—	—	—
2-3/8	4.60	4.70	—	5 100	5 100	5 100	4 600	5 100	—
2-7/8	6.40	6.50	—	4 800	4 800	4 800	4 400	4 800	—
3-1/2	7.70	—	—	3 900	3 900	—	—	—	—
3-1/2	9.20	9.30	—	4 600	4 600	4 600	4 300	4 600	—
3-1/2	10.20	—	—	5 300	5 300	—	—	—	—
4	9.50	—	—	3 600	3 600	—	—	—	—
4	10.70	11.00	—	4 200	—	4 200	—	—	—
4-1/2	12.60	12.75	—	3 900	3 900	3 900	—	—	—

**Table E.56 — Hydrostatic test pressure for Grade J55 tubing**

Labels				Test pressure psi					
1	2			Plain end	Non- upset T&C	External upset			Integral joint
	NU T&C	EU T&C	IJ			Regular coupling	Special-clearance coupling		
							J55	N80	
1	2	3	4	5	6	7	8	9	10
1.050	1.14	1.20	—	9 500	9 500	9 500	—	—	—
1.050	1.48	1.54	—	10 000	—	10 000	—	—	—
1.315	1.70	1.80	1.72	8 900	8 900	8 900	—	—	8 000
1.315	2.19	2.24	—	10 000	—	10 000	—	—	—
1.660	2.09	—	2.10	6 600	—	—	—	—	6 400
1.660	2.30	2.40	2.33	7 400	7 400	7 400	—	—	6 400
1.660	3.03	3.07	—	10 000	—	9 000	—	—	—
1.900	2.40	—	2.40	5 800	—	—	—	—	5 700
1.900	2.75	2.90	2.76	6 700	6 700	6 700	—	—	5 700
1.900	3.65	3.73	—	9 300	—	8 300	—	—	—
2.063	3.24	—	3.25	6 700	—	—	—	—	5 600
2.063	4.50	—	—	9 600	—	—	—	—	—
2-3/8	4.00	—	—	6 200	6 200	—	—	—	—
2-3/8	4.60	4.70	—	7 000	7 000	7 000	6 300	7 000	—
2-7/8	6.40	6.50	—	6 600	6 600	6 600	6 100	6 600	—
3-1/2	7.70	—	—	5 400	5 400	—	—	—	—
3-1/2	9.20	9.30	—	6 400	6 400	6 400	5 900	6 400	—
3-1/2	10.20	—	—	7 300	7 300	—	—	—	—
4	9.50	—	—	5 000	5 000	—	—	—	—
4	10.70	11.00	—	5 800	—	5 800	—	—	—
4-1/2	12.60	12.75	—	5 300	5 300	5 300	—	—	—



**Table E.57 — Hydrostatic test pressure for Grades N80 Type 1 and N80Q tubing**

Labels				Test pressure psi					
1	2			Plain end	Non- upset T&C	External upset			Integral joint
	NU T&C	EU T&C	IJ			Regular coupling	Special-clearance coupling		
							N80	P110	
1	2	3	4	5	6	7	8	9	10
1.050	1.14	1.20	—	10 000	10 000	10 000	—	—	—
1.050	1.48	1.54	—	10 000	—	10 000	—	—	—
1.315	1.70	1.80	1.72	10 000	10 000	10 000	—	—	10 000
1.315	2.19	2.24	—	10 000	—	10 000	—	—	—
1.660	2.30	2.40	2.33	10 000	10 000	10 000	—	—	9 300
1.660	3.03	3.07	—	10 000	—	10 000	—	—	—
1.900	2.75	2.90	2.76	9 800	9 800	9 800	—	—	8 200
1.900	3.65	3.73	—	10 000	—	10 000	—	—	—
2.063	3.24	—	3.25	9 700	—	—	—	—	8 100
2.063	4.50	—	—	10 000	—	—	—	—	—
2-3/8	4.00	—	—	9 000	9 000	—	—	—	—
2-3/8	4.60	4.70	—	10 000	10 000	10 000	9 100	10 000	—
2-3/8	5.80	5.95	—	10 000	10 000	10 000	9 100	10 000	—
2-7/8	6.40	6.50	—	9 700	9 700	9 700	8 800	9 700	—
2-7/8	7.80	7.90	—	10 000	10 000	10 000	8 800	10 000	—
2-7/8	8.60	8.70	—	10 000	10 000	10 000	8 800	10 000	—
3-1/2	7.70	—	—	7 900	7 900	—	—	—	—
3-1/2	9.20	9.30	—	9 300	9 300	9 300	8 500	9 300	—
3-1/2	10.20	—	—	10 000	10 000	—	—	—	—
3-1/2	12.70	12.95	—	10 000	10 000	10 000	8 500	10 000	—
4	9.50	—	—	7 200	7 200	—	—	—	—
4	10.70	11.00	—	8 400	—	8 400	—	—	—
4-1/2	12.60	12.75	—	7 700	7 700	7 700	—	—	—

**Table E.58 — Hydrostatic test pressure for Grade L80 tubing**

Labels				Test pressure psi				
1	2			Plain end	Non- upset T&C	External upset		Integral joint
	NU T&C	EU T&C	IJ			Regular coupling	Special- clearance coupling	
1	2	3	4	5	6	7	8	9
1.050	1.14	1.20	—	10 000	10 000	10 000	—	—
1.050	1.48	1.54	—	10 000	—	10 000	—	—
1.315	1.70	1.80	1.72	10 000	10 000	10 000	—	10 000
1.315	2.19	2.24	—	10 000	—	10 000	—	—
1.660	2.30	2.40	2.33	10 000	10 000	10 000	—	9 300
1.660	3.03	3.07	—	10 000	—	10 000	—	—
1.900	2.75	2.90	2.76	9 800	9 800	9 800	—	8 200
1.900	3.65	3.73	—	10 000	—	10 000	—	—
1.900	4.42	—	—	10 000	—	—	—	—
1.900	5.15	—	—	10 000	—	—	—	—
2.063	3.24	—	3.25	9 700	—	—	—	8 100
2.063	4.50	—	—	10 000	—	—	—	—
2-3/8	4.00	—	—	9 000	9 000	—	—	—
2-3/8	4.60	4.70	—	10 000	10 000	10 000	9 100	—
2-3/8	5.80	5.95	—	10 000	10 000	10 000	9 100	—
2-3/8	6.60	—	—	10 000	—	—	—	—
2-3/8	7.35	7.45	—	10 000	—	10 000	9 100	—
2-7/8	6.40	6.50	—	9 700	9 700	9 700	8 800	—
2-7/8	7.80	7.90	—	10 000	10 000	10 000	8 800	—
2-7/8	8.60	8.70	—	10 000	10 000	10 000	8 800	—
2-7/8	9.35	9.45	—	10 000	—	10 000	8 800	—
2-7/8	10.50	—	—	10 000	—	—	—	—
2-7/8	11.50	—	—	10 000	—	—	—	—
3-1/2	7.70	—	—	7 900	7 900	—	—	—
3-1/2	9.20	9.30	—	9 300	9 300	9 300	8 500	—
3-1/2	10.20	—	—	10 000	10 000	—	—	—
3-1/2	12.70	12.95	—	10 000	10 000	10 000	8 500	—
3-1/2	14.30	—	—	10 000	—	—	—	—
3-1/2	15.50	—	—	10 000	—	—	—	—
3-1/2	17.00	—	—	10 000	—	—	—	—
4	9.50	—	—	7 200	7 200	—	—	—
4	10.70	11.00	—	8 400	—	8 400	—	—
4	13.20	—	—	10 000	—	—	—	—
4	16.10	—	—	10 000	—	—	—	—
4	18.90	—	—	10 000	—	—	—	—
4	22.20	—	—	10 000	—	—	—	—
4-1/2	12.60	12.75	—	7 700	7 700	7 700	—	—
4-1/2	15.20	—	—	9 600	—	—	—	—
4-1/2	17.00	—	—	10 000	—	—	—	—
4-1/2	18.90	—	—	10 000	—	—	—	—
4-1/2	21.50	—	—	10 000	—	—	—	—
4-1/2	23.70	—	—	10 000	—	—	—	—
4-1/2	26.10	—	—	10 000	—	—	—	—

**Table E.59 — Hydrostatic test pressure for Grade C90 tubing**

Labels				Test pressure psi			
1	2			Plain end	Non-upset T&C	External upset regular coupling	Integral joint
	NU T&C	EU T&C	IJ				
1	2	3	4	5	6	7	8
1.050	1.14	1.20	—	10 000	10 000	10 000	—
1.050	1.48	1.54	—	10 000	—	10 000	—
1.315	1.70	1.80	1.72	10 000	10 000	10 000	10 000
1.315	2.19	2.24	—	10 000	—	10 000	—
1.660	2.30	2.40	2.33	10 000	10 000	10 000	10 000
1.660	3.03	3.07	—	10 000	—	10 000	—
1.900	2.75	2.90	2.76	10 000	10 000	10 000	9 200
1.900	3.65	3.73	—	10 000	—	10 000	—
1.900	4.42	—	—	10 000	—	—	—
1.900	5.15	—	—	10 000	—	—	—
2.063	3.24	—	3.25	10 000	—	—	9 200
2.063	4.50	—	—	10 000	—	—	—
2-3/8	4.00	—	—	10 000	10 000	—	—
2-3/8	4.60	4.70	—	10 000	10 000	10 000	—
2-3/8	5.80	5.95	—	10 000	10 000	10 000	—
2-3/8	6.60	—	—	10 000	—	—	—
2-3/8	7.35	7.45	—	10 000	—	10 000	—
2-7/8	6.40	6.50	—	10 000	10 000	10 000	—
2-7/8	7.80	7.90	—	10 000	10 000	10 000	—
2-7/8	8.60	8.70	—	10 000	10 000	10 000	—
2-7/8	9.35	9.45	—	10 000	—	10 000	—
2-7/8	10.50	—	—	10 000	—	—	—
2-7/8	11.50	—	—	10 000	—	—	—
3-1/2	7.70	—	—	8 900	8 900	—	—
3-1/2	9.20	9.30	—	10 000	10 000	10 000	—
3-1/2	10.20	—	—	10 000	10 000	—	—
3-1/2	12.70	12.95	—	10 000	10 000	10 000	—
3-1/2	14.30	—	—	10 000	—	—	—
3-1/2	15.50	—	—	10 000	—	—	—
3-1/2	17.00	—	—	10 000	—	—	—
4	9.50	—	—	8 100	8 100	—	—
4	10.70	11.00	—	9 400	—	9 400	—
4	13.20	—	—	10 000	—	—	—
4	16.10	—	—	10 000	—	—	—
4	18.90	—	—	10 000	—	—	—
4	22.20	—	—	10 000	—	—	—
4-1/2	12.60	12.75	—	8 700	8 700	8 700	—
4-1/2	15.20	—	—	10 000	—	—	—
4-1/2	17.00	—	—	10 000	—	—	—
4-1/2	18.90	—	—	10 000	—	—	—
4-1/2	21.50	—	—	10 000	—	—	—
4-1/2	23.70	—	—	10 000	—	—	—
4-1/2	26.10	—	—	10 000	—	—	—

Table E.60 — Hydrostatic test pressure for Grade T95 tubing

Labels				Test pressure psi			
1	2			Plain end	Non-upset T&C	External upset regular coupling	Integral joint
	NU T&C	EU T&C	IJ				
1	2	3	4	5	6	7	8
1.050	1.14	1.20	—	10 000	10 000	10 000	—
1.050	1.48	1.54	—	10 000	—	10 000	—
1.315	1.70	1.80	1.72	10 000	10 000	10 000	10 000
1.315	2.19	2.24	—	10 000	—	10 000	—
1.660	2.30	2.40	2.33	10 000	10 000	10 000	10 000
1.660	3.03	3.07	—	10 000	—	10 000	—
1.900	2.75	2.90	2.76	10 000	10 000	10 000	9 800
1.900	3.65	3.73	—	10 000	—	10 000	—
1.900	4.42	—	—	10 000	—	—	—
1.900	5.15	—	—	10 000	—	—	—
2.063	3.24	—	3.25	10 000	—	—	9 700
2.063	4.50	—	—	10 000	—	—	—
2-3/8	4.00	—	—	10 000	10 000	—	—
2-3/8	4.60	4.70	—	10 000	10 000	10 000	—
2-3/8	5.80	5.95	—	10 000	10 000	10 000	—
2-3/8	6.60	—	—	10 000	—	—	—
2-3/8	7.35	7.45	—	10 000	—	10 000	—
2-7/8	6.40	6.50	—	10 000	10 000	10 000	—
2-7/8	7.80	7.90	—	10 000	10 000	10 000	—
2-7/8	8.60	8.70	—	10 000	10 000	10 000	—
2-7/8	9.35	9.45	—	10 000	—	10 000	—
2-7/8	10.50	—	—	10 000	—	—	—
2-7/8	11.50	—	—	10 000	—	—	—
3-1/2	7.70	—	—	9 400	9 400	—	—
3-1/2	9.20	9.30	—	10 000	10 000	10 000	—
3-1/2	10.20	—	—	10 000	10 000	—	—
3-1/2	12.70	12.95	—	10 000	10 000	10 000	—
3-1/2	14.30	—	—	10 000	—	—	—
3-1/2	15.50	—	—	10 000	—	—	—
3-1/2	17.00	—	—	10 000	—	—	—
4	9.50	—	—	8 600	8 600	—	—
4	10.70	11.00	—	10 000	—	10 000	—
4	13.20	—	—	10 000	—	—	—
4	16.10	—	—	10 000	—	—	—
4	18.90	—	—	10 000	—	—	—
4	22.20	—	—	10 000	—	—	—
4-1/2	12.60	12.75	—	9 200	9 200	9 200	—
4-1/2	16.20	—	—	10 000	—	—	—
4-1/2	17.00	—	—	10 000	—	—	—
4-1/2	18.90	—	—	10 000	—	—	—
4-1/2	21.50	—	—	10 000	—	—	—
4-1/2	23.70	—	—	10 000	—	—	—
4-1/2	26.10	—	—	10 000	—	—	—

Table E.61 — Hydrostatic test pressure for Grade P110 tubing

Labels			Test pressure psi			
1	2		Plain end	Non-upset T&C	External upset	
	NU T&C	EU T&C			Regular coupling	Special- clearance coupling
1	2	3	4	5	6	7
1.050	1.48	1.54	10 000 (25 800)	— —	10 000 (20 700)	— —
1.315	2.19	2.24	10 000 (24 000)	— —	10 000 (22 500)	— —
1.660	3.03	3.07	10 000 (20 300)	— —	10 000 (18 000)	— —
1.900	3.65	3.73	10 000 (18 500)	— —	10 000 (16 600)	— —
2.063	4.50	—	10 000 (19 200)	— —	— —	— —
2-3/8	4.60	4.70	10 000 (14 100)	10 000 (14 100)	10 000 (14 100)	10 000 (12 600)
2-3/8	5.80	5.95	10 000 (18 800)	10 000 (17 700)	10 000 (16 300)	10 000 (12 600)
2-7/8	6.40	6.50	10 000 (13 300)	10 000 (13 300)	10 000 (13 300)	10 000 (12 100)
2-7/8	7.80	7.90	10 000 (16 900)	10 000 (16 900)	10 000 (16 400)	10 000 (12 100)
2-7/8	8.60	8.70	10 000 (18 900)	10 000 (18 300)	10 000 (16 400)	10 000 (12 100)
3-1/2	9.20	9.30	10 000 (12 800)	10 000 (12 800)	10 000 (12 800)	10 000 (11 700)
3-1/2	12.70	12.95	10 000 (18 900)	10 000 (18 000)	10 000 (17 200)	10 000 (11 700)
NOTE Alternative test pressures are given in parentheses.						

**Table E.62 — Summary of NDE methods for seamless pipe, coupling stock and the body of welded pipe**

Grade	Visual inspection (see 10.14)	Wall thickness determination	Ultrasonic inspection	Flux leakage inspection	Eddy current inspection	Magnetic particle inspection <sup>a</sup>
1	2	3	4	5	6	7
H40 J55 K55 N80 Type 1	R	N	N	N	N	N
N80Q L80 C95 M65	R	R	A	A	A	A
P110	R	R	A	A	A	NA
C90 T95 Q125	R	R	C	B	B	B
Coupling stock - H40, J55, K55, N80 Type1	R	NA	N	N	N	N
Coupling stock - N80Q, L80, C95, P110, C90, T95, Q125	R	R	A	A	A	A

N = not required  
R = required  
A = one method or any combination of methods shall be used  
B = at least one method shall be used in addition to ultrasonic inspection to inspect the outside surface  
C = ultrasonic inspection shall be used to inspect the outside and inside surface  
NA = not applicable

<sup>a</sup> MPI is permitted for end-area inspection. MPI is permitted for pipe-body outside-surface inspection in combination with other methods of pipe body inspection. MPI is permitted for coupling stock outside surface inspection. Coupling stock receiving full length MPI does not require full length wall thickness determination, however, mechanical wall thickness measurement of each end is required.

**Table E.63 — Acceptance (inspection) levels**

Grade	External imperfection		Internal imperfection	
	Longitudinal	Transverse	Longitudinal	Transverse
1	2	3	4	5
<b>Pipe</b>				
N80Q, M65, L80, C95	L4	—	L4	—
P110 to A.10 (SR16)	L4	L4	L4	L4
P110	L2	L2	L2	L2
P110 to A.10 (SR16) and A.3 (SR2)	L2	L2	L2	L2
C90, T95, Q125	UT	L2	L2	L2
	2 <sup>nd</sup> method	L2	L2	—
<b>Weld seam</b>				
P110, Q125	L2	N	L2	N
All other grades	L3	N	L3	N
<b>Coupling stock</b>	L2	L2	N	N

N = not required; Lx = acceptance (inspection) level.

**Table E.64 — Artificial reference indicators**

Acceptance (inspection) level	Notch depth <sup>a</sup> max. %	Notch length max. at full depth in	Width max. in	Radially drilled hole diameter <sup>b</sup> in
1	2	3	4	5
L2	5	2.0	0.040	1/16
L3	10	2.0	0.040	1/8
L4	12.5	2.0	0.040	1/8

NOTE See Figure D.17.

<sup>a</sup> Depth as a percent of specified wall thickness. The depth tolerance shall be  $\pm 15\%$  of the calculated notch depth, with a minimum notch depth of 0.012 in  $\pm 0.002$  in.

<sup>b</sup> Drilled hole diameter (through the pipe wall) shall be based on the drill bit size.

**Table E.65 — Size of stamp markings**

Product	Label 1	Marking height in
Pipe	< 4-1/2	3/16
	$\geq 4-1/2$	1/4
Coupling	For pipe sizes < 4-1/2	1/4
	For pipe sizes $\geq 4-1/2$ to < 7-5/8	3/8
	For pipe sizes $\geq 7-5/8$	1/2

**Table E.66 — Grade colour codes**

Grade	Grade type	Number and colour of bands for pipe, coupling stock and pup joints of length $\geq 6.0$ ft	Colour(s) for coupling	
			Entire coupling	Band(s) <sup>a</sup>
1	2	3	4	5
H40		None or black band at the manufacturer's option	None	Same as for pipe
J55 tubing		One bright green	Bright green	None
J55 casing		One bright green	Bright green	One white
K55		Two bright green	Bright green	None
M65		One bright green, one blue	M65 pipe uses L80 Type 1 couplings	
N80	1	One red	Red	None
N80	Q	One red, one bright green	Red	Green
L80	1	One red, one brown	Red	One brown
L80	9Cr	One red, one brown, two yellow	Red	Two yellow
L80	13Cr	One red, one brown, one yellow	Red	One yellow
C90	1	One purple	Purple	None
C90	2	One purple, one yellow	Purple	One yellow
T95	1	One silver	Silver	None
T95	2	One silver, one yellow	Silver	One yellow
C95		One brown	Brown	None
P110		One white	White	None
Q125	1	One orange	Orange	None
Q125	2	One orange, one yellow	Orange	One yellow
Q125	3	One orange, one green	Orange	One green
Q125	4	One orange, one brown	Orange	One brown

<sup>a</sup> Special-clearance couplings shall also have a black band.

**Table E.67 — Thread type markings**

Product	Thread type	Marked symbol
Casing	Short round	STC
	Long round	LC
	Buttress	BC
	Extreme-line	XC
Tubing	Non-upset	NU
	External upset	EU
	Integral joint	IJ



**Table E.68 — Marking requirements and sequence**

1	2	Mark or symbol <sup>b</sup>	Stencil and/or stamp marking requirements <sup>a</sup>				
			Groups 1 and 3		Groups 2 and 4		All groups
			Pipe and pup-joints	Couplings and accessories	Pipe and pup-joints	Couplings and accessories	Coupling stock
1	2	3	4	5	6	7	8
1	Manufacturer's name or mark	« ... »	D or P	D or P	P	P	P
2	ISO 11960	ISO 11960	D or P	D or P	P	P	P
	Marking to indicate API 5CT is at manufacturer's option or as specified on purchase agreement.	5CT <sup>c</sup>	D or P	D or P	P	P	P
	Date of manufacture as in 11.1.8 or 11.1.9.	« ... »	D or P	D or P	P	P	P
3	Unthreaded pipe or special end finish, if applicable (place symbol after specification marking):						
	— Unthreaded pipe either upset or non-upset	UF	D or P		P		
	— Pipe with special end finish threaded by the pipe mill or processor	SF	D or P		P		
	— Completed couplings or completed accessories threaded with special end finish	SF		D or P		P	
— Coupling stock identification	CS						P
4	Size designation (fill in Label 1 designation from column 1 of Table E.1, E.2 or E.3) Specified diameter for coupling stock	« ... »	P		P		P
5	Mass designation (fill in Label 2 designation from column 2 of Table E.1, E.2 or E.3) Specified wall thickness for coupling stock	« ..... »	D or P		P		P
6	Grade of pipe:						
	— H40	H					
	— J55	J					
	— K55	K					
	— N80 Type 1	N1					
	— N80Q	NQ					
	— M65	M					
	— L80	L					
	— P110	P					
	— C95	C					
	— L80 Type 9Cr	L9					
	— L80 Type 13Cr	L13					
	— C90 Type 1	C90-1					
	— C90 Type 2	C90-2					
	— T95 Type 1	T95-1					
	— T95 Type 2	T95-2					
— Q125 Type 1	Q1						
— Q125 Type 2	Q2						
— Q125 Type 3	Q3						
— Q125 Type 4	Q4						
All grade designations		D or P	D or P	P	P	P	
7	Reduced alternative impact test temperature, if applicable. Fill in specified test temperature for full-size specimens, including ± symbol and °F	« ... »F	P	P	P	P	
8	Heat treatment, if applicable:						
	— J55, K55 or M65 normalized	Z	P	P	P	P	P
— J55, K55 or M65 quenched & tempered	Q	P	P	P	P	P	

**Table E.68 (continued)**

Marking sequence		Mark or symbol <sup>b</sup>	Stencil and/or stamp marking requirements <sup>a</sup>				
			Groups 1 and 3		Groups 2 and 4		All groups
			Pipe and pup-joints	Couplings and accessories	Pipe and pup-joints	Couplings and accessories	Coupling stock
1	2	3	4	5	6	7	8
9	Process of manufacture: — Seamless — Electric-welded All designations	S E	D or P		P		
10	Supplementary requirements, if applicable: — A.2 (SR1) — A.3 (SR2) — A.4 (SR9) (fill in type) — A.8 (SR13) — A.10 (SR16) (fill in minimum full-size energy absorption requirement, in foot pounds, and test temperature including ± symbol and °F) — A.11 (SR22) — Annex H (PSL)	S1 S2 S9Q« ... » S13 S16« ... »F S22 L2 or L3	P P D or P P P P		P P P P P P	P P	P
11	Hydrostatic test pressure <sup>e</sup> (fill in the actual test pressure, in psi) All designations	P« ... »	P		P		
12	Type of thread, if applicable: — For manufacturers, processors or threaders of casing buttress, extreme-line or round threads (fill in type of thread from Table E.66) — For threaders of tubing threads (fill in type of thread from Table E.67)	« ... » « ... »	P P		P P		
13	Full-length drift test, if applicable: — Standard (casing or tubing) — Alternative (casing or tubing) where « ... » is the size of the alternative drift — For casing specified for tubing service and drift-tested in accordance with 8.10 All designations	D DA« ..... » DT42	P		P		
14	Serialization of Grades C90, T95 and Q125				D <sup>d</sup> or P	D <sup>d</sup> or P	P
15	Tin plating of couplings, if applicable	T		P		P	
16	Couplings H40, J55 and K55 only visually inspected	V		P			
NOTE See 11.4 for mandatory colour code requirements.							
<sup>a</sup> D indicates for optional (die) stamping; P indicates a requirement for (paint) stencilling. Optional marking is permitted as specified in 11.1 and 11.2.							
<sup>b</sup> A blank space, « ..... », indicates information to be filled in.							
<sup>c</sup> The manufacturer may include "API" before "5CT".							
<sup>d</sup> Stamp marking shall conform to the requirements of 11.2.5.							
<sup>e</sup> Pipe can be identified as manufactured to SI units by the marked hydro-test pressure which will be less than 100 (MPa), while the pressure marked for pipe manufactured to USC units will be over 1 000 (psi). This information is used to clearly identify the units used for CVN markings, which shall be in the same unit system as the pressure markings.							

**Table E.69 — Retention of records**

Requirement	Subclause reference
<b>Chemical properties</b>	
Heat analysis	10.3.2
Product analysis	10.3.3
<b>Mechanical properties</b>	
Tensile tests	7.2, 10.4.7
Control tests	10.4.2
Impact tests	7.4, 7.5, 7.6, 10.7
Couplings	9.5
Hardness tests	7.7, 7.8, 7.9 and 10.6
Hardenability test (Grades C90 and T95)	7.10, 10.9
Grain size (Grades C90 and T95)	7.11, 10.8
<b>Hydrostatic tests</b>	
Tester recorder charts	10.12.1
Testing	10.12.1
<b>Manufacturer certification</b>	
Results of all required tests (Group 4)	13.3
Sulfide stress cracking test (Grades C90 and T95)	7.14, 10.10
Calibration	Various

**Table E.70 — SR11.1 Distance between plates for flattening tests**

Grade	$D/t$ ratio	Distance between plates max. in
P110	All ratios	$D \times (1.086 - 0.0163 D/t)$
Q125	All ratios	$D \times (1.092 - 0.0140 D/t)$

$D$  is the specified outside diameter of pipe, in inches.  
 $t$  is the specified wall thickness of the pipe, in inches.

**Table E.71 — SR12.1 Inspection lot sample sizes vs.  $F$  factor**

Sample size	$F$	Sample size	$F$
1	2	3	4
3	13.857	16	4.534
4	9.215	18	4.415
5	7.501	20	4.319
6	6.612	25	4.143
7	6.061	30	4.022
8	5.686	35	3.937
9	5.414	40	3.866
10	5.203	45	3.811
12	4.900	50	3.766
14	4.690	$\infty$	3.090

**Table E.72 — SR12.2 Probability of defective pipes**

Probability of one length being defective	Probability that one or more defective lengths is included in a string of 100 pipes
1/10	0.999 97 (or 100 %)
1/100	0.634 (or 63 %)
1/1 000	0.095 (or 10 %)
1/10 000	0.009 95 (or 1 %)

**Table E.73 — SR16.1 Transverse impact specimen size required**

Label 1	Calculated wall thickness required to machine transverse Charpy impact specimens in		
	Full size	¾-size	½-size
1	2	3	4
3-1/2	0.809	0.711	0.612
4	0.752	0.654	0.555
4-1/2	0.712	0.614	0.515
5	0.681	0.583	0.484
5-1/2	0.656	0.558	0.459
6-5/8	0.616	0.518	0.419
7	0.606	0.508	0.409
7-5/8	0.591	0.493	0.394
7-3/4	0.588	0.490	0.391
8-5/8	0.572	0.474	0.375
9-5/8	0.557	0.459	0.360
10-3/4	0.544	0.446	0.347
11-3/4	0.535	0.437	0.338
13-3/8	0.522	0.424	0.325
16	0.508	0.410	0.311
18-5/8	0.497	0.399	0.300
20	0.493	0.395	0.296

NOTE The wall thicknesses in columns 2, 3 and 4 that are in excess of the maximum wall thicknesses for ISO/API pipe are for information only. The above provides a 0.020 in ID and a 0.020 in OD machining allowance.

**Table E.74 — SR16.2 Longitudinal impact specimen size required**

Label 1	Calculated wall thickness required to machine longitudinal Charpy impact specimens in		
	Full size	¾-size	½-size
1	2	3	4
1 050	0.472	0.374	0.275
1 315	0.464	0.366	0.267
1 660	0.458	0.360	0.261
1 900	0.455	0.357	0.258
2 063	0.453	0.355	0.256
2-3/8	0.450	0.352	0.253
2-7/8	0.448	0.350	0.251
3-1/2	0.445	0.347	0.248
4	0.444	0.346	0.247
4-1/2	0.443	0.345	0.246
5	0.442	0.344	0.245
5-1/2	0.441	0.343	0.244
6-5/8	0.440	0.342	0.243
7	0.440	0.342	0.243
7-5/8	0.439	0.341	0.242
7-3/4	0.439	0.341	0.242
8-5/8	0.439	0.341	0.242
9-5/8	0.438	0.340	0.241
10-3/4	0.438	0.340	0.241
11-3/4	0.437	0.339	0.240
13-3/8	0.437	0.339	0.240
16	0.436	0.338	0.239
18-5/8	0.436	0.338	0.239
20	0.436	0.338	0.239

NOTE The wall thicknesses in columns 2, 3 and 4 that are in excess of the maximum wall thicknesses for ISO/API pipe are for information only. The above provides a 0.020 in ID and a 0.020 in OD machining allowance.

**Table E.75 — SR16.3 Acceptable size impact specimens and absorbed energy reduction factor**

Test specimen size	Specimen dimensions mm	Reduction factor
Full size	10.0 × 10.0	1.00
¾-size	10.0 × 7.5	0.80
½-size	10.0 × 5.0	0.55

**Table E.76 — SR16.4 Hierarchy of test specimen orientation and size**

Choice	Orientation	Size
1 <sup>st</sup>	Transverse	Full size
2 <sup>nd</sup>	Transverse	¾-size
3 <sup>rd</sup>	Transverse	½-size
4 <sup>th</sup>	Longitudinal	Full size
5 <sup>th</sup>	Longitudinal	¾-size
6 <sup>th</sup>	Longitudinal	½-size

**Table E.77 — SR16.5 Transverse Charpy absorbed energy requirements — Grade N80 Type 1**

Maximum specified wall thickness in	Minimum transverse absorbed energy ft-lb
0.442	10
0.524	11
0.606	12
0.689	13
0.771	14
0.853	15
0.935	16
1.018	17

For wall thicknesses greater than shown above, the requirements shall be according to the equations for the wall thickness and grade.

NOTE Wall thicknesses greater than those of standard ISO/API pipe are shown here for information for special applications.

**Table E.78 — SR16.6 Longitudinal Charpy absorbed energy requirements — Grade N80 Type 1**

Maximum specified wall thickness in	Minimum longitudinal absorbed energy ft·lb
0.421	20
0.462	21
0.504	22
0.545	23
0.586	24
0.627	25
0.668	26
0.709	27
0.750	28
0.791	29
0.833	30
0.874	31
0.915	32
0.956	33
0.997	34
1.038	35

For wall thicknesses greater than shown above, the requirements shall be according to the equations for the wall thickness and grade.

NOTE Wall thicknesses greater than those of standard ISO/API pipe are shown here for information for special applications.

**Table E.79 — SR16.7 Test temperature reduction for sub-size specimens — Grades H40, J55 and K55 only**

Specimen size mm	Specified pipe wall thickness in	Temperature reduction °F
10.0 × 7.5	> 0.394	5
10.0 × 5.0	> 0.394	20
10.0 × 5.0	0.295 to 0.394	15
10.0 × 5.0	0.264 to 0.291	10
10.0 × 5.0	0.236 to 0.260	5

Table E.80 — SR22-1

Label 1	Label 2	Grade <sup>a</sup>	Outside dia. <i>D</i> in	Drift in	Coupling OD regular <i>W</i> in	Power turns min. N	Length <sup>b</sup> <i>L<sub>g</sub></i> in	Approx. start torque		Recom- mended compound mass <sup>c</sup> g
								Tin ft-lb	Phosphate ft-lb	
1	2	3	4	5	6	7	8	9	10	11
4-1/2	11.60	J/K55	4.500	3.875	5.000	3	3.250	130	217	15
4-1/2	11.60	L/N80	4.500	3.875	5.000	3	3.250	124	206	15
4-1/2	13.50	L/N80	4.500	3.795	5.000	3	3.250	136	227	15
4-1/2	11.60	C90	4.500	3.875	5.000	3	3.250	127	—	15
4-1/2	13.50	C90	4.500	3.795	5.000	3	3.250	143	—	15
4-1/2	11.60	C/T95	4.500	3.875	5.000	3	3.250	130	—	15
4-1/2	13.50	C/T95	4.500	3.795	5.000	3	3.250	146	—	15
4-1/2	11.60	P110	4.500	3.875	5.000	3	3.250	130	—	15
4-1/2	13.50	P110	4.500	3.795	5.000	3	3.250	148	—	15
5	13.00	J/K55	5.000	4.369	5.563	3	3.625	116	193	20
5	15.00	J/K55	5.000	4.283	5.563	3	3.625	125	208	20
5	15.00	L/N80	5.000	4.283	5.563	3.5	3.625	164	273	20
5	18.00	L/N80	5.000	4.151	5.563	3.5	3.625	220	367	20
5	15.00	C90	5.000	4.283	5.563	3	3.625	198	—	20
5	18.00	C90	5.000	4.151	5.563	3	3.625	238	—	20
5	15.00	C/T95	5.000	4.283	5.563	3.5	3.625	202	—	20
5	18.00	C/T95	5.000	4.151	5.563	3.5	3.625	243	—	20
5	15.00	P110	5.000	4.283	5.563	3.5	3.625	208	—	20
5	18.00	P110	5.000	4.151	5.563	3.5	3.625	248	—	20
5-1/2	15.50	J/K55	5.500	4.825	6.050	3	3.750	162	270	25
5-1/2	17.00	J/K55	5.500	4.767	6.050	3	3.750	192	320	25
5-1/2	17.00	L/N80	5.500	4.767	6.050	4	3.750	240	400	25
5-1/2	20.00	L/N80	5.500	4.653	6.050	4	3.750	273	456	25
5-1/2	17.00	C90	5.500	4.767	6.050	3	3.750	180	—	25
5-1/2	20.00	C90	5.500	4.653	6.050	3	3.750	205	—	25
5-1/2	17.00	C/T95	5.500	4.767	6.050	3.5	3.750	222	—	25
5-1/2	20.00	C/T95	5.500	4.653	6.050	3.5	3.750	251	—	25
5-1/2	17.00	P110	5.500	4.767	6.050	4	3.750	270	—	25
5-1/2	20.00	P110	5.500	4.653	6.050	4	3.750	301	—	25
6-5/8	20.00	J/K55	6.625	5.924	7.390	3	4.125	162	269	30
6-5/8	24.00	J/K55	6.625	5.796	7.390	3	4.125	202	337	30
6-5/8	24.00	L/N80	6.625	5.796	7.390	4	4.125	332	554	30
6-5/8	28.00	L/N80	6.625	5.666	7.390	4	4.125	387	646	30
6-5/8	32.00	L/N80	6.625	5.550	7.390	4	4.125	427	712	30
6-5/8	24.00	C90	6.625	5.796	7.390	4	4.125	351	—	30
6-5/8	28.00	C90	6.625	5.666	7.390	4	4.125	408	—	30
6-5/8	32.00	C90	6.625	5.550	7.390	4	4.125	451	—	30
6-5/8	24.00	C/T95	6.625	5.796	7.390	4	4.125	356	—	30
6-5/8	28.00	C/T95	6.625	5.666	7.390	4	4.125	411	—	30
6-5/8	32.00	C/T95	6.625	5.550	7.390	4	4.125	453	—	30
6-5/8	24.00	P110	6.625	5.796	7.390	4.5	4.125	417	—	30
6-5/8	28.00	P110	6.625	5.666	7.390	4.5	4.125	483	—	30
6-5/8	32.00	P110	6.625	5.550	7.390	4.5	4.125	532	—	30

Table E.80 (continued)

Label 1	Label 2	Grade <sup>a</sup>	Outside dia. <i>D</i> in	Drift in	Coupling OD regular <i>W</i> in	Power turns min. N	Length <sup>b</sup> <i>L<sub>g</sub></i> in	Approx. start torque		Recommended compound mass <sup>c</sup> g
								Tin ft-lb	Phosphate ft-lb	
1	2	3	4	5	6	7	8	9	10	11
7	23.00	J/K55	7.000	6.241	7.656	4	4.250	237	395	35
7	26.00	J/K55	7.000	6.151	7.656	4	4.250	273	455	35
7	23.00	L/N80	7.000	6.241	7.656	5.5	4.250	414	690	35
7	26.00	L/N80	7.000	6.151	7.656	5.5	4.250	486	810	35
7	29.00	L/N80	7.000	6.059	7.656	5.5	4.250	543	904	35
7	32.00	L/N80	7.000	5.969	7.656	5.5	4.250	585	975	35
7	23.00	C90	7.000	6.241	7.656	4.5	4.250	354	—	35
7	26.00	C90	7.000	6.151	7.656	4.5	4.250	404	—	35
7	29.00	C90	7.000	6.059	7.656	4.5	4.250	449	—	35
7	32.00	C90	7.000	5.969	7.656	4.5	4.250	489	—	35
7	23.00	C/T95	7.000	6.241	7.656	4.5	4.250	361	—	35
7	26.00	C/T95	7.000	6.151	7.656	4.5	4.250	410	—	35
7	29.00	C/T95	7.000	6.059	7.656	4.5	4.250	455	—	35
7	32.00	C/T95	7.000	5.969	7.656	4.5	4.250	494	—	35
7	26.00	P110	7.000	6.151	7.656	5	4.250	474	—	35
7	29.00	P110	7.000	6.059	7.656	5	4.250	525	—	35
7	32.00	P110	7.000	5.969	7.656	5	4.250	567	—	35
7-5/8	26.40	J/K55	7.625	6.844	8.500	3.5	4.375	244	406	40
7-5/8	26.40	L/N80	7.625	6.844	8.500	5	4.375	482	804	40
7-5/8	29.70	L/N80	7.625	6.750	8.500	5	4.375	566	943	40
7-5/8	33.70	L/N80	7.625	6.640	8.500	5	4.375	649	1081	40
7-5/8	39.00	L/N80	7.625	6.500	8.500	5	4.375	737	1228	40
7-5/8	26.40	C90	7.625	6.844	8.500	4.5	4.375	409	—	40
7-5/8	29.70	C90	7.625	6.750	8.500	4.5	4.375	470	—	40
7-5/8	33.70	C90	7.625	6.640	8.500	4.5	4.375	532	—	40
7-5/8	39.00	C90	7.625	6.500	8.500	4.5	4.375	600	—	40
7-5/8	26.40	C/T95	7.625	6.844	8.500	4.5	4.375	417	—	40
7-5/8	29.70	C/T95	7.625	6.750	8.500	4.5	4.375	476	—	40
7-5/8	33.70	C/T95	7.625	6.640	8.500	4.5	4.375	537	—	40
7-5/8	39.00	C/T95	7.625	6.500	8.500	4.5	4.375	603	—	40
7-5/8	29.70	P110	7.625	6.750	8.500	5	4.375	551	—	40
7-5/8	33.70	P110	7.625	6.640	8.500	5	4.375	620	—	40
7-5/8	39.00	P110	7.625	6.500	8.500	5	4.375	695	—	40
8-5/8	32.00	J/K55	8.625	7.796	9.625	3.5	4.750	306	510	50
8-5/8	36.00	J/K55	8.625	7.700	9.625	3.5	4.750	356	593	50
8-5/8	36.00	L/N80	8.625	7.700	9.625	5.5	4.750	614	1024	50
8-5/8	40.00	L/N80	8.625	7.600	9.625	5.5	4.750	657	1095	50
8-5/8	44.00	L/N80	8.625	7.500	9.625	5.5	4.750	737	1229	50
8-5/8	49.00	L/N80	8.625	7.386	9.625	5.5	4.750	796	1326	50
8-5/8	36.00	C90	8.625	7.700	9.625	4.5	4.750	650	—	50
8-5/8	40.00	C90	8.625	7.600	9.625	4.5	4.750	723	—	50
8-5/8	44.00	C90	8.625	7.500	9.625	4.5	4.750	789	—	50
8-5/8	49.00	C90	8.625	7.386	9.625	4.5	4.750	857	—	50
8-5/8	36.00	C/T95	8.625	7.700	9.625	5	4.750	690	—	50
8-5/8	40.00	C/T95	8.625	7.600	9.625	5	4.750	772	—	50
8-5/8	44.00	C/T95	8.625	7.500	9.625	5	4.750	843	—	50
8-5/8	49.00	C/T95	8.625	7.386	9.625	5	4.750	914	—	50
8-5/8	40.00	P110	8.625	7.600	9.625	5.5	4.750	799	—	50
8-5/8	44.00	P110	8.625	7.500	9.625	5.5	4.750	901	—	50
8-5/8	49.00	P110	8.625	7.386	9.625	5.5	4.750	975	—	50



Table E.80 (continued)

Label 1	Label 2	Grade <sup>a</sup>	Outside dia. <i>D</i> in	Drift in	Coupling OD regular <i>W</i> in	Power turns min. N	Length <sup>b</sup> <i>L<sub>g</sub></i> in	Approx. start torque		Recom- mended compound mass <sup>c</sup> g
								Tin ft-lb	Phosphate ft-lb	
1	2	3	4	5	6	7	8	9	10	11
9-5/8	36.00	J/K55	9.625	8.765	10.625	3.5	5.000	393	507	55
9-5/8	40.00	J/K55	9.625	8.679	10.625	3.5	5.000	439	572	55
9-5/8	40.00	L/N80	9.625	8.679	10.625	5.5	5.000	673	1121	55
9-5/8	43.50	L/N80	9.625	8.599	10.625	5.5	5.000	767	1278	55
9-5/8	47.00	L/N80	9.625	8.525	10.625	5.5	5.000	823	1371	55
9-5/8	53.50	L/N80	9.625	8.500 <sup>d</sup>	10.625	5.5	5.000	923	1539	55
9-5/8	40.00	C90	9.625	8.679	10.625	5	5.000	675	—	55
9-5/8	43.50	C90	9.625	8.599	10.625	5	5.000	737	—	55
9-5/8	47.00	C90	9.625	8.525	10.625	5	5.000	790	—	55
9-5/8	53.50	C90	9.625	8.500 <sup>d</sup>	10.625	5	5.000	988	—	55
9-5/8	40.00	C/T95	9.625	8.679	10.625	5.5	5.000	762	—	55
9-5/8	43.50	C/T95	9.625	8.599	10.625	5.5	5.000	833	—	55
9-5/8	47.00	C/T95	9.625	8.525	10.625	5.5	5.000	893	—	55
9-5/8	53.50	C/T95	9.625	8.500 <sup>d</sup>	10.625	5.5	5.000	972	—	55
9-5/8	43.50	P110	9.625	8.599	10.625	6	5.000	914	—	55
9-5/8	47.00	P110	9.625	8.525	10.625	6	5.000	978	—	55
9-5/8	53.50	P110	9.625	8.500 <sup>d</sup>	10.625	6	5.000	1092	—	55

<sup>a</sup> L/N80 implies L80 Type 1, N80 Type 1 and N80Q.  
<sup>b</sup> End of pipe to apex of triangle.  
<sup>c</sup> The recommended mass of thread compound shown in this table is for a compound containing metals, including lead (i.e. former API Bull 5A2) which has a specific gravity of approximately 2. Use of compounds such as ISO 13678 requires less mass to achieve an equivalent volume of thread compound. Use of excessive thread compound may be detrimental to leak resistance.  
 NOTE For the purposes of this provision, API RP 5A3 is equivalent to ISO 13678.  
<sup>d</sup> The alternative size drift (see Table E.32) is shown.

**Table E.81 — Marking instructions for API licensees (see Annex F)**

1	Marking sequence	Mark or Symbol <sup>b</sup>	Stencil and/or stamp marking requirements <sup>a</sup>				
			Groups 1 and 3		Groups 2 and 4		All groups
			Pipe and pup joints	Couplings and accessories	Pipe and pup joints	Couplings and accessories	Coupling stock
2	3	4	5	6	7	8	
1	Licensed manufacturer's name or mark (optional; neither is required)	«.....»	D or P	D or P	P	P	P
2	ISO 11960 and/or API 5CT at manufacturer's option or as specified on purchase agreement.	ISO 11960 <sup>c</sup> 5CT <sup>d</sup>	D or P D or P	D or P D or P	P P	P P	P P
	Manufacturer's option:						
	API license number	«.....»	D or P	D or P	P	P	P
	API monogram	«.....»	D or P	D or P	P	P	P
	Date of manufacture as in F.1.8 or F.1.9	«.....»	D or P	D or P	P	P	P
3	Unthreaded pipe or special end finish, if applicable (place symbol after specification marking):						
	— Unthreaded pipe either upset or non-upset	UF	D or P		P		
	— Pipe with special end finish threaded by the pipe mill or processor	SF	D or P	D or P	P	P	
	— Completed couplings or completed accessories threaded with special end finish	SF					
	— Coupling stock identification	CS					P
4	Size designation (fill in Label 1 designation from column 1 of Table E.1, E.2 or E.3) Specified diameter for coupling stock	«.....»	P		P		P
5	Mass designation (fill in Label 2 designation from column 2 of Table E.1, E.2 or E.3) Specified wall thickness for coupling stock	«.....»	D or P		P		P
6	Grade of pipe:						
	— H40	H					
	— J55	J					
	— K55	K					
	— N80 Type 1	N1					
	— N80Q	NQ					
	— M65	M					
	— L80	L					
	— P110	P					
	— C95	C					
	— L80 Type 9Cr	L9					
	— L80 Type 13Cr	L13					
	— C90 Type 1	C90-1					
	— C90 Type 2	C90-2					
	— T95 Type 1	T95-1					
	— T95 Type 2	T95-2					
	— Q125 Type 1	Q1					
	— Q125 Type 2	Q2					
	— Q125 Type 3	Q3					
	— Q125 Type 4	Q4					
	All grade designations		D or P	D or P	P	P	P
7	Reduced alternative impact test temperature, if applicable. Fill in specified test temperature for full-size specimens, including ± symbol and °F:	«.....»F	P	P	P	P	
8	Heat treatment, if applicable:						
	— J55, K55 or M65 normalized	Z	P	P	P	P	P
	— J55, K55 or M65 quenched & tempered	Q	P	P	P	P	P

Table E.81 (continued)

Marking sequence		Mark or Symbol <sup>b</sup>	Stencil and/or stamp marking requirements <sup>a</sup>				
			Groups 1 and 3		Groups 2 and 4		All groups
			Pipe and pup joints	Couplings and accessories	Pipe and pup joints	Couplings and accessories	Coupling stock
1	2	3	4	5	6	7	8
9	Process of manufacture: — Seamless — Electric-welded All designations	S E	D or P		P		
10	Supplementary requirements, if applicable: — A.2 (SR1) — A.3 (SR2) — A.4 (SR9) (fill in type) — A.8 (SR13) — A.10 (SR16) (fill in minimum full-size energy absorption requirement in foot pounds and test temperature including ± symbol and °F) — A.11 (SR22) — Annex H (PSL)	S1 S2 S9Q«...» S13  S16«...»F S22 L2 or L3	P P   P P P	  D or P  D P	P P   P P P	  P P  D P	      P
11	Hydrostatic test pressure <sup>e</sup> (fill in the actual test pressure in psi) All designations	P«...»	P		P		
12	Type of thread, if applicable: — For manufacturers, processors or threaders of casing buttress, extreme-line or round threads (fill in type of thread from Table E.67). — For threaders of tubing threads (fill in type of thread from Table E.67)	«...» «...»	P P		P P		
13	Full length drift test, if applicable: — Standard (casing or tubing) — Alternative (casing or tubing) where «...» is the size of the alternative drift. — For casing specified for tubing service and drift-tested in accordance with 8.10 All designations	D DA«...» DT42	  P		  P		
14	Serialization of Grades C90, T95 and Q125				D <sup>f</sup> or P	D <sup>f</sup> or P	P
15	Tin plating of couplings, if applicable	T		P		P	
16	Couplings H40, J55 and K55 only visually inspected	V		P			
NOTE See F.4 for mandatory colour code requirements.							
<p><sup>a</sup> D = optional (die) stamping; P = Requirement for (paint) stencilling. Optional marking is permitted as specified in F.1 and F.2.</p> <p><sup>b</sup> A blank space, «...», indicates information to be filled in.</p> <p><sup>c</sup> The manufacturer may include "API" before "5CT".</p> <p><sup>d</sup> Alternative markings for the standards are: "5CT", "API 5CT", "ISO 11960 5CT".</p> <p><sup>e</sup> Pipe can be identified as manufactured to SI units by the marked hydro-test pressure which will be less than 100 (MPa), while the pressure marked for pipe manufactured to USC units (psi) will be over 1 000. This information is used to clearly identify the units used for CVN markings, which shall be in the same unit system as the pressure markings.</p> <p><sup>f</sup> Stamp marking shall conform to the requirements of F.2.5.</p>							

## Annex F (informative)

### Marking instructions for API licensees

#### F.1 General

**F.1.1** Products manufactured in conformance with this International Standard may be marked by the API licensee as specified in Clause 11 in this International Standard or as specified in this annex. Products to which the API monogram is applied shall be marked according to this annex.

**F.1.2** For all manufacturers except threaders, the marking instructions in this annex, except those in F.6, are applicable. For threaders, the marking instructions in F.5 and F.6 and Tables C.81 or Table E.81 are applicable. Processors shall remove any identity that is not indicative of the new condition of the product as a result of heat treating (for example, prior grade identity and original pipe manufacturer's name or logo).

**F.1.3** Products shall be colour-coded as specified in F.4.

**F.1.4** Products shall be marked by stencilling, or a combination of stencilling and stamping, at the option of the manufacturer, as stipulated, with two exceptions:

- by agreement between purchaser and manufacturer, stamping can be required, in which case a combination of stamping and stencil marking shall be used;
- at the option of the manufacturer, hot-rolled or hot-stamped markings on pipe and couplings may be substituted for die-stamped markings and are permitted at intervals along the length.

**F.1.5** Requirements for optional stamp markings are specified in F.2, and stencil markings shall be as specified in F.3. Marking instructions and sequence of markings are specified in Table C.81 or Table E.81, which includes only those items that are stamped or stencilled for product identification. If die-stamp marking is selected, it is not required to also stencil-mark the information. Examples of markings are shown in Figure D.23. Marking shall not overlap and shall be applied in such a manner as not to injure the product.

**F.1.6** Additional markings for other compatible standards are allowed to be placed following the required marking sequence. Such markings are at the option of the manufacturer or as requested by the purchaser.

**F.1.7** In a circumstance where it is necessary to re-mark product with the original marking information, the accuracy and traceability of the transferred markings shall be the responsibility of the entity re-marking the product. The transferred markings shall include the words "transferred by << >>" with the name of the entity responsible for transferring the markings listed between the << >>.

**F.1.8** The complete monogram consists of the following: "5CT", license number of the plant doing the manufacturing, the API monogram and the date of manufacture. The date of manufacture is defined for marking purposes as either:

- a) a two-digit number consisting of the last digit of the year followed by the calendar quarter in which the markings of Clause 11 are completed or
- b) a three-digit number consisting of last digit of the year followed by a two digit number indicating the month in which the markings of Clause 11 are completed.

**F.1.9** Products manufactured in accordance with this third edition of ISO 11960 during the period of overlap of application (see Foreword) with the second edition shall be identified by using either "0" as the overlap period designation rather than the quarter, or "00" as the overlap period designation rather than the month.

The overlap period designation "0" or "00" applies to the pipe body characteristics and does not apply to changes in API Spec 5B.

**F.1.10** Other additional markings are allowed and may be applied as desired by the manufacturer or as requested by the purchaser, but shall be applied after the markings specified in Table C.81 or Table E.81.

## F.2 Stamp marking requirements

### F.2.1 Methods

Methods of stamp marking shall be as follows:

Number	Stamping method
1	Hot-rolled or hot-stamped markings
2	Cold die stamping with standard dies
3	Cold die stamping with interrupted dot face dies
4	Cold die stamping with rounded-face dies
5	Vibratory

After stamp marking, Group 2 and Group 4 products may require subsequent heat treatment as specified in F.2.5. Such heat treatment shall be in accordance with 6.2 of this International Standard. The sequence of stamp markings shall be as shown in Table C.81 or Table E.81.

### F.2.2 Size

Sizes of stamp markings shall be as shown in Table C.65 or Table E.65.

### F.2.3 Location

Placements of these markings on casing, liners and tubing sizes Label 1: 1.660 and larger shall be on the outside surface of each length within approximately 0,3 m (1 ft) from the coupling or box, either end of plain-end pipe or either end of pin-by-pin threaded pipe. The optional stamp marking on sizes smaller than Label 1: 1.660 may be on a metal tag affixed to each length or, for bundled tubing, stamped on a metal tag affixed to each bundle.

### F.2.4 Groups 1 and 3

When specified on the purchase agreement, products shall be stamped by one or more of the methods in F.2.1 at the option of the manufacturer.

### F.2.5 Groups 2 and 4

When specified on the purchase agreement, products may be stamped by one or more of the methods in F.2.1 at the option of the manufacturer.

Group 2 (except Grades C90 and T95) shall be heat-treated subsequent to using method 2 in F.2.1.

Group 2 (Grades C90 and T95 only) and Group 4 products shall be heat-treated subsequent to using methods 2 and 4 in F.2.1, with the following exceptions:

— the make-up triangle mark;

- when the stamp markings are removed by grinding, machining, threading or cropping to a depth not less than twice the depth of the stamping;
- when not removing the stamping is by agreement between purchaser and manufacturer.

### F.2.6 Make-up triangle marking

For buttress casing in all sizes and grades and for round thread casing in sizes Label 1: 16 and larger in Grades H40, J55, K55 and M65, the make-up triangle shall be stamped on the outside of each length on both ends. By agreement between purchaser and manufacturer, the make-up triangle may be replaced with a transverse white paint band 10 mm (3/8 in) wide by 76 mm (3 in) long. To assist in locating the triangle or transverse white paint band on buttress casing, a 25 mm (1 in) wide by 610 mm (24 in) long longitudinal white paint stripe shall be placed adjacent to the triangle or transverse paint band on the field end; additionally, a 25 mm (1 in) wide by 100 mm (4 in) long longitudinal white paint stripe shall be placed adjacent to the triangle or transverse paint band on the mill end.

For Groups 1 and 3, the triangle shall be stamped by method 2 or 4 only.

For Group 2 (Grades C90 and T95 only), the triangle shall be stamped by method 3 only.

For Group 2 (except Grades C90 and T95) and Group 4, the triangle shall be stamped by method 3 or 4 only.

## F.3 Stencil marking requirements

Stencil markings shall be placed on the outside surface of each length of pipe, beginning at least 0,6 m (2 ft) from the coupling or box or from either end of plain-end pipe, pin-by-pin threaded pipe or coupling stock. For accessories and pup joints less than 1,8 m (6 ft) in length, the required stencil markings may be placed on a decal attached to the outside surface within 0,3 m (1 ft) of the end. These markings shall be separated by a dash or shall be adequately spaced.

The sequence of stencil markings shall be as specified in Table C.81 or Table E.81, except the thread marking shall be at a location convenient to the manufacturer.

## F.4 Colour identification

### F.4.1 Colour coding

Each product shall be colour-coded as described in F.4.2 to F.4.6, unless otherwise specified on the purchase agreement:

### F.4.2 Product 1,8 m (6 ft) and longer

One or more of the following methods shall be used.

- a) For threaded pipe, pup joints and accessories: paint a band encircling the product at a distance not greater than 0,6 m (24 in) from the coupling or internally threaded end.
- b) For plain-end or pin-by-pin threaded product: paint a band encircling the product at a distance not greater than 0,6 m (24 in) from either end.
- c) Coupling: paint the entire outside surface of the coupling, including the appropriate coupling colour bands.
- d) If the pipe is furnished with special-clearance couplings or if the pipe and couplings are of a different grade (except Grades H40, J55 and K55 applied in accordance with 9.2.1), paint both the pipe and couplings as specified in items a), b) and c) above.

**F.4.3 Loose couplings**

Paint the entire surface of the coupling, including the appropriate colour bands.

**F.4.4 Special-clearance couplings**

Paint the colours indicative of the steel grade from which the couplings are manufactured and also paint a black band around the centre.

**F.4.5 Pup joints and accessories shorter than 1,8 m (6 ft) in length**

Paint the entire surface except the threads, including the appropriate colour bands.

**F.4.6 Grade colour codes**

The colour and number of bands used to represent each grade shall be as shown in Table C.66 or Table E.66.

**F.5 Thread and end-finish marking — All groups****F.5.1 API thread marking**

For manufacturers, thread identification shall be stencilled on casing with round, buttress or extreme-line threads. For threaders, thread identification is required on casing and tubing. This thread identification shall be as shown in Table C.67 or Table E.67.

**F.5.2 Unfinished and special end-finish markings**

Different marking is required for

- a) plain-end pipe furnished either upset or non-upset or
- b) pipe with special end-finish not specified herein but having the body of the pipe manufactured in accordance with the requirements specified herein or
- c) completed couplings and completed accessories furnished with special end-finish not specified herein but which meet all the other requirements specified herein for these products except dimensions.

This marking shall be as shown in Table C.81 or Table E.81.

**F.6 Pipe threader marking requirements — All groups**

Pipe threaded by a facility other than the original pipe manufacturer shall be identified by a stamp or stencil consistent with F.1, F.2 and F.3 adjacent to the threads with the name or mark of the threader, the specification mark, and size and type of thread as listed in F.5 and Table C.67 or Table E.67.

The threader shall mark on the body of the pipe the actual hydrostatic test pressure, unless the pipe has been previously tested to the pressure required for the thread as shown in Tables C.45 to C.61 or Tables E.45 to E.61 and marked as specified in Table C.81 or Table E.81.

EXAMPLE For Label 1: 7, Label 2: 29.00, C95, long-thread coupling:

Case 1) If the pipe manufacturer produced UF pipe and hydrostatic pressure-tested to 34,5 MPa (5 000 psi) based on the documented design basis of the tester for 177,8 mm (7 in) pipe (see 10.12.3), and marked P34,5 (P5000), then the threader shall pressure-test the pipe to 60,5 MPa (8 800 psi) and mark the pipe in accordance with Figure D.16.

Case 2) If the pipe manufacturer produced UF pipe and hydrostatic pressure tested to 61,0 MPa (8 900 psi) and marked the pipe P61,0 (P8900) then the threader is not required to pressure test or mark the test pressure.

The markings applied to the body of the pipe by the original pipe manufacturer shall not be removed or altered.

Use of the letters "API" to identify or certify that threads on tubular goods comply with API Spec 5B is not permitted.



## Annex G (informative)

### Procedures used to convert from USC units to SI units

#### G.1 Background

The following procedures were adopted in this International Standard for converting units from the United States Customary (USC) system into the Système Internationale (SI).

#### G.2 General

##### G.2.1 Rounding

The last retained digit in a number was unchanged when the next digit was less than 5 or raised when it was greater than 5.

When the digit following the last retained digit was exactly 5 followed by all zeros, the last retained digit was unchanged if it was even, or was raised if it was odd.

##### G.2.2 Fractions

Fractions or numbers with fractions in USC units were converted to the full decimal equivalents in USC units without rounding. The full decimal equivalents in USC units were then converted to SI values using the following formula:

$$N_m = 25,4 \times N$$

where

$N_m$  is the SI equivalent, expressed in millimetres, of a USC fraction or USC number with fractions (in inches);

$N$  is the full decimal equivalent, expressed in inches, of a USC fraction or number with fractions which has not been rounded.

The converted SI values, in millimetres, for the equivalent of USC fractions or numbers with fractions were rounded to the appropriate number of places for the application.

##### G.2.3 Tolerances

The formula used was the same as that given in G.2.2.

The USC values for tolerances, except angular misalignment, were converted to SI values based on the appropriate conversion factor.

The converted SI values for the tolerances, except angular misalignment, were rounded to the same number of decimal places as the SI value to which they were applicable.

## G.3 Pipe dimensions

### G.3.1 Outside diameter

The USC values for outside diameters of pipe and couplings were converted to SI values using the following formula:

$$D_m = 25,4 \times D$$

where

$D_m$  is the outside diameter, expressed in millimetres;

$D$  is the outside diameter, expressed in inches.

The converted SI values for the outside diameters of pipe and couplings were rounded to the nearest 0,01 mm.

### G.3.2 Wall thickness

The USC values for wall thickness were converted to SI values using the following formula:

$$t_m = 25,4 \times t$$

where

$t_m$  is the wall thickness, expressed in millimetres;

$t$  is the wall thickness, expressed in inches.

The converted SI values for wall thickness were rounded to the nearest 0,01 mm.

### G.3.3 Inside diameter

The SI values for the inside diameters of pipe were calculated (not converted) using the following formula:

$$d_m = D_m - (2 \times t_m)$$

where

$d_m$  is the inside diameter, expressed in millimetres;

$D_m$  is the outside diameter, expressed in millimetres;

$t_m$  is the wall thickness, expressed in millimetres.

The calculated SI values for inside diameters of pipe were rounded to the nearest 0,01 mm.

### G.3.4 Diameters and lengths of upsets

The USC values for the diameters and lengths of upsets were converted to SI values using the following formula:

$$U_m = 25,4 \times U$$

where

$U_m$  is the upset dimension, expressed in millimetres;

$U$  is the upset dimension, expressed in inches.

The converted SI values for the diameters and lengths of upsets were rounded to the nearest 0,01 mm.

## G.4 Drift diameters

### G.4.1 Drift diameter, standard drift size, Table C.31

The SI values for standard drift diameters of pipe were calculated (not converted) using the following formula:

$$dd_m = d_m - dc_m$$

where

$dd_m$  is the drift diameter, expressed in millimetres;

$d_m$  is the inside diameter, expressed in millimetres;

$dc_m$  is the drift constant, expressed in millimetres.

The drift constants used are given below.

Product	Label 1	$dc_m$ mm
Casing and liners	< 9-5/8	3,18
	9-5/8 to 13-3/8	3,97
	> 13-3/8	4,76
Tubing	≤ 2-7/8	2,38
	> 2-7/8	3,18
Casing specified by the purchaser to be used in tubing service where Label 1 is larger than 4-1/2 but smaller than 10-3/4	> 4-1/2 to 8-5/8	2,38
	> 8-5/8 to 10-3/4	3,18

The calculated SI values for standard drift diameters were rounded to the nearest 0,01 mm.

### G.4.2 Drift diameter, alternative drift size, Table C.32

The USC values for alternative drift diameters were converted to SI values using the following formula:

$$dd_{a,m} = 25,4 \times dd_a$$

where

$dd_{a,m}$  is the alternative drift diameter, expressed in millimetres;

$dd_a$  is the alternative drift diameter, expressed in inches.

The converted SI values for alternative drift diameters were rounded to the nearest 0,01 mm.

### G.4.3 Drift diameter, finished bored upset of extreme-line casing, column 12 of Table C.26

The USC values for the drift diameter for the finished bored upset of extreme-line casing were converted to SI values using the following formula:

$$dd_{e,m} = 25,4 \times dd_e$$

where

$dd_{e,m}$  is the drift diameter for the finished bored ends of extreme-line casing, expressed in millimetres;

$dd_e$  is the drift diameter for the finished bored ends of extreme-line casing, expressed in inches.

The converted SI values for the drift diameters for the finished bored ends of extreme-line casing were rounded to the nearest 0,01 mm.

#### G.4.4 Drift diameter, for the full length of extreme-line casing, column 13 of Table C.26

Following the custom in USC units, the SI values for the drift diameters for the full length of extreme-line casing are equal to the standard drift diameter for plain-end casing (see G.4.1) except for the following product which use a smaller diameter drift because of the heavy internal upset.

Product which require a smaller full-length diameter drift because of the heavy internal upset		Product in columns 1 and 2 are drifted full length with the standard drift for the corresponding product in columns 3 and 4	
Label 1	Label 2	Label 1	Label 2
1	2	3	4
5	15.00	5	≥ 18.00
5-1/2	15.50	5-1/2	≥ 20.00
5-1/2	17.00	—	—
6-5/8	24.00	6-5/8	≥ 28.00
7	23.00	7	≥ 26.00
7-5/8	26.40	7-5/8	≥ 29.70
8-5/8	32.00	8-5/8	≥ 36.00
9-5/8	40.00	9-5/8	≥ 40.50

## G.5 Coupling dimensions

### G.5.1 Length of couplings

The USC values for the lengths of couplings in inches and fractions of inches were converted to decimal equivalents in USC units without rounding. The full decimal equivalent of the lengths of the couplings in USC units were then converted to SI units using the following formula:

$$N_{L,m} = 25,4 \times N_L$$

where

$N_{L,m}$  is the length of couplings, expressed in millimetres;

$N_L$  is the length of couplings, expressed in inches, without rounding.

The converted SI values for the lengths of couplings were rounded to the nearest 0,01 mm.

### G.5.2 Diameter of coupling recess

The USC values for diameters of the coupling recess were converted to SI values using the following formula:

$$Q_m = 25,4 \times Q$$

where

$Q_m$  is the diameter of the coupling recess, expressed in millimetres;

$Q$  is the diameter of the coupling recess, expressed in inches.

The converted SI values for the diameters of the coupling recess were rounded to the nearest 0,01 mm.

### G.5.3 Width of the coupling bearing face

The USC values for the widths of the bearing face of couplings were converted to SI values using the following formula:

$$b_m = 25,4 \times b$$

where

$b_m$  is the width of the coupling bearing face, expressed in millimetres;

$b$  is the width of the coupling bearing face, expressed in inches.

The converted SI values for the widths of the coupling bearing faces were rounded to the nearest 0,01 mm.

### G.5.4 Diameter at the root of the coupling thread at the end of the pipe in the power-tight position

The USC values for the diameter at the root of the coupling thread at the end of the pipe in the power-tight position were calculated without rounding and were then converted to SI values using the following formula:

$$d_{1m} = 25,4 \times d_1$$

where

$d_{1m}$  is the diameter, expressed in millimetres, at the root of the coupling thread at the end of the pipe in the power-tight position;

$d_1$  is the unrounded diameter, expressed in inches, at the root of the coupling thread at the end of the pipe in the power-tight position.

The converted SI values for the diameter at the root of the coupling thread at the end of the pipe in the power-tight position were rounded to the nearest 0,01 mm.

## G.6 Linear mass

### G.6.1 Nominal threaded and coupled linear mass

The USC values for nominal threaded and coupled linear mass were converted to SI units using the following formula:

$$w_m = 1,488\ 16 \times w$$

where

$w_m$  is the linear mass, expressed in kilograms per metre;

$w$  is the linear mass, expressed in pounds per foot.

The converted SI values for nominal threaded and coupled linear mass were rounded to the nearest 0,01 kg/m.

### G.6.2 Plain-end linear mass

The plain-end linear masses expressed in SI units were calculated (not converted) using the following formula:

$$w_{pe,m} = 0,024\ 661\ 5 \times (D_m - t_m) \times t_m$$

where

$w_{pe,m}$  is the plain-end linear mass, expressed in kilograms per metre;

$D_m$  is the outside diameter, expressed in millimetres;

$t_m$  is the wall thickness, expressed in millimetres.

The calculated SI values for plain-end linear masses were rounded to the nearest 0,01 kg/m.

### G.6.3 Coupling masses

The USC values for the calculated masses of couplings were converted to SI values using the following formula:

$$m_{c,m} = 0,453\ 592 \times m_c$$

where

$m_{c,m}$  is the mass of the coupling, expressed in kilograms;

$m_c$  is the mass of the coupling, expressed in pounds.

The converted SI values for calculated masses of couplings were rounded to the nearest 0,01 kg.

### G.6.4 Mass gain or loss due to end finish

The USC values for mass gain or loss due to end finish were converted to SI units using the following formula:

$$e_{e,m} = 0,453\ 592 \times e_e$$

where

$e_{e,m}$  is the mass gain or loss due to end finish, expressed in kilograms;

$e_e$  is the mass gain or loss due to end finish, expressed in pounds.

The converted SI values for mass gain or loss due to end finish were rounded to the nearest 0,01 kg.

## G.7 Tensile and flattening tests

### G.7.1 Yield strength

The USC values for yield strength were converted to SI values using the following formula:

$$YS_m = 0,006\ 894\ 76 \times YS$$

where

$YS_m$  is the yield strength, expressed in megapascals;

$YS$  is the yield strength, expressed in pounds per square inch.

The converted SI values for strengths were rounded to the nearest megapascal.

### G.7.2 Tensile strength

The USC values for tensile strength were converted to SI values using the following formula:

$$TS_m = 0,006\ 894\ 76 \times TS$$

where

$TS_m$  is the tensile strength, expressed in megapascals;

$TS$  is the tensile strength, expressed in pounds per square inch.

The converted SI values for strengths were rounded to the nearest megapascal.

### G.7.3 Elongation

The values for elongation, in SI units, were calculated (not converted) using the following formula:

$$e_m = 1\ 944 \times A_m^{0,2} / U_m^{0,9}$$

where

$e_m$  is the minimum elongation, expressed as a percentage;

$A_m$  is the cross-sectional area of the tensile specimen, expressed in square millimetres;

$U_m$  is the specified minimum tensile strength, expressed in megapascals.

The calculated SI values for elongation were rounded to the nearest 1,0 % for values of 10,0 % and larger, and to the nearest 0,5 % for values less than 10,0 %.

### G.7.4 Flattening test formula

The formula used to determine the maximum distance between the plates during a flattening test had the following form:

$$D_f = D \times [Z_1 - (Z_2 \times D / t)]$$

where

$D_f$  is the maximum distance between the plates during a flattening test, expressed in inches or millimetres depending on the units of  $D$  and  $t$ ;

$Z_1$  is a constant;

$Z_2$  is a constant;

$D$  is the specified outside diameter of the pipe, expressed in inches or millimetres;

$t$  is the specified wall thickness of the pipe, expressed in inches or millimetres.

The same values for the constants  $Z_1$  and  $Z_2$  were used regardless of whether the units for  $D$  and  $t$  were inches or millimetres, provided the units for both  $D$  and  $t$  were the same.

## G.8 Charpy impact energy requirements

### G.8.1 Critical thickness for couplings with API threads, Table C.8

The USC values for the critical thickness for couplings with API threads were converted to SI values using the following formula:

$$t_{c,m} = 25,4 \times t_c$$

where

$t_{c,m}$  is the critical thickness, expressed in millimetres;

$t_c$  is the critical thickness, expressed in inches.

The calculated SI values were rounded to the nearest 0,01 mm.

### G.8.2 Charpy impact energy

The USC values for standard CVN impact energy requirements that are not determined by an equation (for example, as used in Table C.11 and other minimum requirements) were converted to SI values using the following formula:

$$C_m = 1,355\ 82 \times C$$

where

$C_m$  is the standard Charpy impact energy, expressed in joules;

$C$  is the standard Charpy impact energy, expressed in foot-pounds (e.g. 8, 15, 20, 30 ft-lb).

The converted SI values for standard CVN impact energy were rounded to the nearest joule.

### G.8.3 Minimum absorbed energy requirements for couplings, Tables C.12 to C.18

The SI values for the minimum absorbed energy requirements for couplings with API threads were calculated using the following formulae:

For Grades N80 Type 1, N80Q, L80, C90, C95, T95, P110 and Q125



Transverse Charpy absorbed energy requirements for couplings:

$$C_{ctm} = f_c \times YS_{max} \times [(0,001\ 18 \times t_c) + 0,012\ 59]$$

Longitudinal Charpy absorbed energy requirements for couplings

$$C_{clm} = f_c \times YS_{max} \times [(0,002\ 36 \times t_c) + 0,025\ 18]$$

where

$C_{ctm}$  is the minimum transverse Charpy impact energy for couplings, expressed in joules;

$C_{clm}$  is the minimum longitudinal Charpy impact energy for couplings, expressed in joules;

$YS_{max}$  is the specified maximum yield strength of the coupling, expressed in megapascals;

$t_c$  is the critical thickness shown in Table C.8 for couplings with API threads, expressed in millimetres;

$f_c$  is a factor depending on the size of the Charpy impact specimen:

1,00 for full-size specimens (10 mm × 10 mm);

0,80 for ¾-size specimens (10 mm × 7,5 mm);

0,55 for ½-size specimens (10 mm × 5 mm).

The calculated SI values were rounded to the nearest joule.

NOTE 1 The maximum-size fully machined transverse and longitudinal Charpy impact specimens for couplings for API threads can be found in API Bull 5C3. These sizes are included in Tables C.12 to C.16 and used in the calculation of the Charpy requirements shown in those tables.

NOTE 2 The absorbed energy requirements in Tables C.17 and C.18 are for full-size test specimens where the factor  $f$  is set to 1,00.

### G.8.4 Absorbed energy requirements for pipe

The SI values for the maximum specified wall thickness for various grades of pipe for minimum absorbed energy values from full-size test specimens were calculated based on the equations given in a) and b) below. In these equations the following is applicable:

$C_{pt,m}$  is the minimum transverse Charpy impact energy for pipe, expressed in joules;

$C_{pl,m}$  is the minimum longitudinal Charpy impact energy for pipe, expressed in joules;

$YS_{max}$  is the specified maximum yield strength of the pipe, expressed in megapascals;

$YS_{min}$  is the specified minimum yield strength of the pipe, expressed in megapascals.

The rounding procedures of ISO 31-0 or ASTM E29 shall be followed. For example, when calculating the requirements for 27 J, 27,499 999 99 should be used for  $C_{pt,m}$  or  $C_{pl,m}$  (since that rounds to 27). Similarly, when calculating the requirements for 28 J, 28,500 000 00 should be used for  $C_{pt,m}$  or  $C_{pl,m}$  (since that rounds to 28). The wall thickness that results from the calculation shall be rounded down to two decimal places.

a) Grades N80Q, L-80, C90, C95, T95 and P110

Transverse Charpy absorbed energy requirements for pipe, Table C.19:

$$t = [(C_{pt,m}/YS_{min}) - 0,012\ 59] / 0,001\ 18$$

Longitudinal Charpy absorbed energy requirements for pipe, Table C.20:

$$t = [(C_{pl,m}/YS_{\min}) - 0,025\ 18] / 0,002\ 36$$

b) Grade Q125

Transverse Charpy absorbed energy requirements for pipe, Table C.19:

$$t = [(C_{pt,m}/YS_{\max}) - 0,012\ 59] / 0,001\ 18$$

Longitudinal Charpy absorbed energy requirements for pipe, Table C.20:

$$t = [(C_{pl,m}/YS_{\max}) - 0,025\ 18] / 0,002\ 36$$

### **G.8.5 Calculated wall thickness required to machine transverse and longitudinal Charpy impact specimens from pipe and couplings, Tables C.21 and C.22**

The SI values for the wall thicknesses required to machine transverse and longitudinal Charpy impact test specimens from pipe and couplings were calculated using the following formulae:

Transverse Charpy impact specimens, Table C.21:

$$t_t = (D_m/2) - [(D_m/2)^2 - 756,25]^{0,5} + 1,00 + w_{Cs}$$

Longitudinal Charpy impact specimens, Table C.22:

$$t_l = (D_m/2) - [(D_m/2)^2 - 25]^{0,5} + 1,00 + w_{Cs}$$

where

$t_t$  is the calculated value for the wall thickness, expressed in millimetres, required to machine transverse Charpy impact test specimens from pipe and couplings;

$t_l$  is the calculated value for the wall thickness, expressed in millimetres, required to machine longitudinal Charpy impact test specimens from pipe and couplings;

$D_m$  is the specified outside diameter of the pipe or coupling, expressed in millimetres;

$w_{Cs}$  is the width of the Charpy impact test specimen, expressed in millimetres:

10,0 mm for full-size specimens;

7,5 mm for  $\frac{3}{4}$ -size specimens;

5,0 mm for  $\frac{1}{2}$ -size specimens.

In the above formulae, a machining allowance of 1,00 mm is included (USC formulae allowed 0,020 in on the inside pipe surface and 0,020 in on the outside surface or 1,00 mm total for the purposes of this calculation).

The calculated SI values for the wall thicknesses required to machine transverse and longitudinal Charpy impact test specimens from pipe and couplings were rounded to the nearest 0,01 mm.

## G.9 Hydrostatic testing

### G.9.1 Hydrostatic test pressure for plain end pipe

The SI values for hydrostatic test pressures for plain end pipe were calculated (not converted) using the SI outside diameter, wall thickness and yield strengths in the following formula:

$$p_m = 2 \times f \times YS_m \times t_m / D_m$$

where

$p_m$  is the hydrostatic test pressure, expressed in megapascals;

$D_m$  is the outside diameter, expressed in millimetres;

$YS_m$  is the yield strength, expressed in megapascals;

$t_m$  is the wall thickness, expressed in millimetres;

$f$  is a factor, based on the size and grade of the pipe as found in the following:

Grades	Label 1	Standard test		Alternative test	
		$f$	Maximum pressure MPa	$f$	Maximum pressure MPa
1	2	3	4	5	6
H40, J55, K55	< 10-3/4	0,8	69,0	—	—
	≥ 10-3/4	0,6	69,0	0,8	69,0
M65, N80 Type 1, N80Q, L80, C95, T95	all sizes	0,8	69,0	—	—
P110, Q125	all sizes	0,8	69,0	0,8	no max.

The calculated SI values for hydrostatic test pressures for plain-end pipe were rounded to the nearest 0,5 MPa up to a maximum of 69,0 MPa.

### G.9.2 Hydrostatic test pressure for couplings

The SI values for the maximum hydrostatic test pressures for couplings were calculated (not converted) using the following formula from API Bul 5C3:

$$p_m = 0,8 \times YS_m \times (W_m - d_{1m}) / W_m$$

where

$p_m$  is the hydrostatic test pressure, expressed in megapascals;

$W_m$  is the outside diameter of the coupling, expressed in millimetres;

$YS_m$  is the yield strength, expressed in megapascals;

$d_{1m}$  is the diameter, expressed in millimetres, at the root of the coupling thread at the plane of the end of the pipe in the power-tight position.

The calculated SI values for the maximum hydrostatic test pressures for couplings were rounded to the nearest 0,5 Mpa.

### G.9.3 Internal pressure leak-resistance at E1 or E7 plane

The SI values for internal pressure leak-resistance at the E1 plane of round thread connections and at the E7 plane of buttress thread casing were calculated (not converted) using the following formula from API Bul 5C3:

$$p_{LRm} = E \times T \times N \times P \times [W_m^2 - E_s^2] / [2 \times E_s \times W_m^2]$$

where

$p_{LRm}$  is the internal pressure leak-resistance at the E1 or E7 plane, expressed in megapascals;

$W_m$  is the outside diameter of the coupling, expressed in millimetres;

$YS_m$  is the yield strength, expressed in megapascals;

$d_{1m}$  is the diameter, expressed in millimetres, at the root of the coupling thread at the plane of the end of the pipe in the power-tight position;

$E$  is the modulus of elasticity, 207 000 MPa;

$E_s$  is the pitch diameter at the seal, expressed in millimetres:

$E_1$  for round threads;

$E_7$  for buttress threads;

$N$  is the number of power turns;

$P$  is the thread pitch, expressed in inches per thread;

$T$  is the thread taper, expressed in inches per inch.

The calculated SI values for internal pressure leak-resistance limits were rounded to the nearest 0,5 MPa.

### G.9.4 Hydrostatic test pressure for threaded and coupled pipe

The hydrostatic test pressure for threaded and coupled pipe is the lowest pressure of:

- the hydrostatic test pressure for plain-end pipe,
- the maximum hydrostatic test pressure for couplings, or
- the internal pressure leak-resistance.

## G.10 Other

### G.10.1 Temperature

The temperatures in degrees Fahrenheit (USC) were converted to temperatures in degrees Celsius (SI) using the following formula:

$$^{\circ}\text{C} = (^{\circ}\text{F} - 32) \times 5/9$$

where

$^{\circ}\text{C}$  is the temperature, expressed in degrees Celsius;

$^{\circ}\text{F}$  is the temperature, expressed in degrees Fahrenheit.

The converted SI values for temperatures were rounded to the nearest degree.

When the temperature being converted was over 600 °F, the number was rounded to the most rational value rounded to the nearest 5 °C. For example, 750 °F converts to 399 °C but the rational conversion is 400 °C.

### **G.10.2 Torque**

The USC values for make-up torque may be converted to SI values using the following formula:

$$T_m = 1,355\ 82 \times T$$

where

$T_m$  is the torque, expressed in newton-metres;

$T$  is the torque, expressed in foot-pounds.

The converted SI values for make-up torque may be rounded to the nearest newton metre.

**NOTE** This International Standard does not include requirements for torque. However, as this International Standard is the primary casing and tubing standard, a conversion procedure for torque is included here for convenience of the user.

## Annex H (normative)

### Product Specification Levels

#### H.1 General

This annex describes Product Specification Level (PSL) requirements for PSL-2 and PSL-3, for all Grades except H-40 and L-80 9Cr, that may be specified by the purchaser. Higher PSL requirements may be furnished at the option of the manufacturer. The requirements for PSL-2 and PSL-3 are in addition to those for PSL-1, which are the basis of this International Standard. All requirements for PSL-3 are in addition to requirements for PSL-2, except as otherwise indicated by PSL-3 requirements. Accordingly, in the body of this International Standard, clauses and subclauses that give additional PSL-3 requirements are identified as only PSL-3. Those clauses and subclauses that give PSL-2 requirements are identified as both PSL-2 and PSL-3.

Table H.1, at the end of this annex, is a reference table for PSL-2 and PSL-3 requirements.

NOTE The numbers in parentheses following titles to clauses and subclauses in this annex are the paragraph numbers in the body of this International Standard which are amended by the requirements of the PSL.

#### H.2 Heat treatment

##### H.2.1 Grade J55 and K55, PSL-2 (6.2.2)

Product shall be full-body normalized or normalized and tempered and, if upset, shall be normalized or normalized and tempered after upsetting.

##### H.2.2 Grade N80Q, PSL-3 (6.2.2)

Only Grade N80Q shall be furnished for PSL-3.

#### H.3 Straightening, PSL-2

##### H.3.1 Grades C90 and T95 (6.3.4)

Product, when necessary, shall be either cold rotary straightened followed by stress relief at 30 °C to 56 °C (50 °F to 100 °F) below the final specified temper temperature, or hot rotary straightened with an exit temperature not more than 165 °C (300 °F) below the final specified temper temperature. When necessary, light gag straightening shall be permitted.

##### H.3.2 Grades C95 and P110 (6.3.1, 6.3.3)

Gag press straightening or hot rotary straightening [400 °C (750 °F) minimum at end of rotary straightening unless a higher minimum temperature is specified on the purchase agreement] is acceptable. If hot rotary straightening is not possible, the pipe may be cold rotary straightened provided it is then stress-relieved at 510 °C (950 °F) or higher.

## H.4 Chemical composition (7.1)

### H.4.1 Grades C90, T95, and Q125 PSL-2

Chemical composition shall be Type 1.

### H.4.2 Grades C90 and T95, PSL-3

The manufacturer shall inform the purchaser at the time of inquiry of the minimum and maximum concentrations for all elements deliberately added to each heat, regardless of the purpose of the addition.

## H.5 Yield strength — Grade Q125, PSL-3 (7.2.3)

The maximum yield strength shall be 965 MPa (140 ksi).

## H.6 Charpy V-notch tests

### H.6.1 Charpy V-notch test properties — General requirements, Grades N80 Type 1, N80Q, L80 Type 1, C90, C95, T95, P110 and Q125, PSL-2 (7.3.1)

In order to meet the test requirement, a 75 % minimum shear area is necessary, in accordance with ASTM E23.

### H.6.2 Charpy V-notch — Absorbed energy requirements for pipe, PSL-2

#### H.6.2.1 All grades except M65 and Q125 (7.5.1 and 7.5.3)

Impact testing shall be carried out in accordance with A.10 (SR16). The test temperature shall be 21 °C (70 °F) for Grades J55 and K55 and 0 °C (32 °F) for all other grades, or a lower temperature by agreement between purchaser and manufacturer.

#### H.6.2.2 Grade Q125 (7.5.4)

Statistical impact testing is required in accordance with A.7 (SR12).

## H.7 Hardenability — Minimum percentage martensite required for quenched and tempered products

### H.7.1 Grade L80 Type 1, PSL-2 (7.10.2)

A full-body as-quenched sample shall be taken in accordance with a documented procedure to confirm sufficient hardening for each size, mass, chemical composition, and austenitize and quench combination. To be in compliance with this International Standard, the mean hardness numbers (see 10.6.10) obtained during the documented procedure shall equal or exceed the hardness corresponding to 90 % minimum martensite, as determined by the following equation:

$$\text{HRC}_{\min} = 58 \times (\% \text{ carbon}) + 27$$

**H.7.2 Grades C90 AND T95, PSL-3 (7.10.1)**

The mean hardness numbers obtained as specified in H.7.1 shall equal or exceed the hardness corresponding to a minimum of 95 % martensite as determined by the following equation:

$$\text{HRC}_{\min} = 59 \times (\% \text{ carbon}) + 29$$

For pipes with a wall thickness of 30 mm (1.181 in) or larger, an alternative requirement may be used by agreement between manufacturer and purchaser.

**H.8 Inside surface preparation — Grade L80 13Cr, PSL-2 (7.12)**

The pipe inside surface properties shall meet the requirements for Sa 2½ in ISO 8501-1. During surface preparation, any blasting media that may cause surface iron contamination shall not be used.

**H.9 Sulfide stress-cracking (SSC) test — PSL-3****H.9.1 Grades C90 and T95 (7.14)**

If Method A is specified for the SSC test (in accordance with ANSI-NACE TM0177-96), manufacturers shall for each heat demonstrate that the product meets or exceeds the 90 %  $YS_{\min}$  threshold for three specimens, one each from the ends of three different pipes selected from the start, middle and end of the heat/heat treatment lot. A retest of one specimen may be carried out if only one of the initial samples fails. If the retest specimen fails, the heat shall be rejected.

By agreement between the purchaser and manufacturer, the number of specimens per heat/heat treatment lot required may be reduced to no less than one with a process control plan that is sufficient to ensure that the product meets or exceeds the 90 %  $YS_{\min}$  threshold.

**H.9.2 Grade L80 13Cr**

If requested by the purchaser, the manufacturer shall for each heat demonstrate that the product meets or exceeds the 80 % SMYS threshold using test Method A in accordance with ANSI-NACE TM0177-96. The test solution shall have a pH of 3,5 and a partial pressure of H<sub>2</sub>S of 10 kPa (1.5 psi).

**H.10 Processing of pin ends — All groups, PSL-2 (8.12.7)**

Pin threads shall be abrasive-blasted unless processed by any appropriate technique, including primary machining, which has been agreed between the purchaser and manufacturer to be sufficient to avoid the presence of material susceptible to detaching or causing galling during make-up.

**H.11 Seal-ring couplings — All groups, PSL-2 (9.11)**

Seal-ring grooves shall be machined in the same set-up used to machine the box threads. The seal-ring groove eccentricity shall be no greater than 0,13 mm (0.005 in) and shall be verified for each machine set-up. Seal-ring groove eccentricity is the maximum difference between the values of the distance from the root of the seal-ring groove to the minor cone of the coupling threads in a plane at any location around the circumference.



**H.12 Processing of box ends — All groups, PSL-2 (9.13.1)**

Box threads shall be abrasive-blasted unless processed by any appropriate technique, including primary machining, which has been agreed between the purchaser and manufacturer to be sufficient to avoid the presence of material susceptible to detaching or causing galling during make-up.

**H.13 Frequency of tensile testing — Casing and tubing, Grades N80 Type 1, and N80Q, PSL-2 (10.4.3)**

The frequency of testing shall be the same as for Grade L80 Type 1.

**H.14 Hardness testing, PSL-3****H.14.1 Hardness test — Grades N80Q, L80 Type 1, C95, P110 and Q125 (10.6.1, 10.6.4 and 10.6.8)**

The manufacturer shall apply a process control plan which has been demonstrated to the satisfaction of the purchaser as sufficient to ensure that each pipe body, each upset and each coupling has mechanical properties conforming to the requirements of this International Standard. If this condition is not fulfilled, each pipe body, each upset and each coupling shall be surface-hardness-tested. Hardness minimum and maximum values, when not specified in this International Standard, shall be in accordance with the manufacturer's specifications or by agreement between the purchaser and the manufacturer.

**H.14.2 Sampling and test specimen location — Non-upset pipe, Grades C90 and T95 (10.6.5)**

A test ring shall be cut from both ends of each pipe.

**H.15 Metallographic evaluation for EW pipe — Grades J55, K55, M65, N80 Type 1, N80Q, L80 Type 1, and C95, PSL-2 (10.11)**

A metallographic evaluation shall be performed at the beginning of the welding process for each size of tubular, at least every 4 h during the welding and after any substantial interruption of the welding process. The samples shall be obtained prior to heat treatment.

**H.16 Hydrostatic test — Grades J55 and K55, PSL-2 (10.12.2)**

Alternative test pressures shall be used for sizes above Label 1: 9-5/8.

**H.17 Wall thickness (10.13.4)****H.17.1 All groups, PSL-2**

Wall thickness shall be measured and recorded for the full length, with a minimum coverage of 25 % of the surface area covered by the automatic system.

**H.17.2 All groups, PSL-3**

Wall thickness shall be measured and recorded for the full length, with a minimum coverage of 100 % of the surface area covered by the automatic system. The minimum measured wall thickness for each pipe shall be reported. Traceability per pipe is not required.

## **H.18 Non-destructive examination (NDE)**

### **H.18.1 Full-body NDE — Casing and tubing**

#### **H.18.1.1 Grades J55 and K55, PSL-2 (10.15.5)**

All pipe shall be inspected for the detection of longitudinal imperfections on the outside and inside surfaces to acceptance level L4 by one or more of the methods specified in 10.15.5.

#### **H.18.1.2 Grades M65, N80 Type 1 and N80Q, PSL-2 (10.15.5 and 10.15.6)**

All pipe shall be inspected for the detection of longitudinal and transverse imperfections on the outside and inside surfaces to acceptance level L3 by ultrasonic or EMI testing in accordance with A.2 (SR1).

#### **H.18.1.3 Grades L80 Type 1, L80 13CR, and C95, PSL2 (10.15.6)**

All pipe shall be inspected for the detection of both longitudinal and transverse imperfections on the outside and inside surfaces to acceptance level L2 by one or more of the methods specified in 10.15.8. Magnetic particle testing is only allowed as a second full-length inspection.

#### **H.18.1.4 Grades J55, K55, and M65, PSL-3 (10.15.5 and 10.15.6)**

All pipe shall be inspected for the detection of both longitudinal and transverse imperfections on the outside and inside surfaces to acceptance level L2 by one or more of the methods specified in 10.15.6 a, b, or c. Magnetic particle testing is only allowed as a second full-length inspection.

#### **H.18.1.5 Grades N80Q, L80 Type 1, L80 13CR, C95, and P110, and P110 A.10 (SR16), PSL-3 (10.15.6, 10.15.7 and 10.15.8)**

All pipe shall be inspected for the detection of both longitudinal and transverse imperfections on the outside and inside surfaces to acceptance level L2 in accordance with ISO 9303 or ASTM E213 (longitudinal) and ISO 9305 or ASTM E213 (transverse).

In addition, all pipe shall be inspected for the detection of imperfections on the outside surface by one of the methods in 10.15.9.

### **H.18.2 NDE of the weld seam of welded pipe — Grades K55 and M65, PSL-2 (10.15.10)**

The weld seam inspection required by this International Standard shall be performed after the hydrostatic test using ultrasonic test methods.

### **H.18.3 NDE of untested pipe ends — All groups, PSL-3 (10.15.12)**

The inspection of untested end area shall be performed using the wet magnetic particle method, or a method agreed between purchaser and manufacturer, after end-finishing and before coupling installation of threaded and coupled tubulars.

### **H.18.4 NDE of coupling stock — Groups 2, 3 and 4, PSL-2 (10.15.11)**

#### **H.18.4.1 Permitted imperfections before machining**

Coupling stock for couplings that will be fully machined may have imperfections on the unmachined surfaces, however the final machined surfaces shall meet the specified dimensions and the surface inspection criteria of 9.14 (A.4.3 SR9.3).

**H.18.4.2 Further evaluation**

Coupling stock containing defects may be given further evaluation in accordance with 10.15.14, except the maximum size of the non-surface-breaking imperfection specified in 8.13.1 c) shall be reduced to 32 mm<sup>2</sup> (0.05 in<sup>2</sup>). Coupling stock containing defects shall either be given disposition in accordance with 10.15.17, or the section of coupling stock containing the defect shall be cut off within the limits of the requirements on length specified on the coupling stock purchase agreement.

**H.18.4.3 Ultrasonic testing — Through-wall**

Coupling stock shall be inspected full length for the entire through-wall thickness, from the OD surface to the FBH reference indicator, by the manufacturer using ultrasonic compression-wave techniques to detect and identify imperfections.

Reference indicator	Metal distance <sup>a</sup>	Minimum coverage <sup>b</sup>
6,4 mm (1/4 in) ID FBH (one only)	90 %	25 %
<sup>a</sup> Distance from the OD surface to the bottom of the FBH, expressed as a percent of the specified minimum wall thickness. The metal distance tolerance shall be ± 1,5 % of the calculated metal distance. <sup>b</sup> Determine coverage in accordance with 10.15.4 a).		

**H.18.4.4 Ultrasonic testing — Inside surface**

Coupling stock shall be inspected for longitudinal and transverse imperfections on the inside surface using ultrasonic shear-wave techniques to acceptance level L4. By agreement between the purchaser and manufacturer, alternative NDE methods which demonstrate the capability to detect the reference indicators may be used.

**H.18.5 NDE of coupling stock — Groups 2, 3 and 4, PSL-3 (10.15.11)****H.18.5.1 Minimum coverage**

Coupling stock shall be inspected in accordance with H.18.4.3, except the minimum coverage shall be 100 %.

**H.18.5.2 Acceptance level**

Coupling stock shall be inspected in accordance with H.18.4.4, except the acceptance level shall be L3 with a maximum notch length of 25 mm (1 in).

**H.19 Thread protectors — All grades, PSL-2 (12.2.1)**

Thread protectors shall meet the requirement of annex I or be as specified on the purchase agreement.

**H.20 Certification requirements — Groups 1, 2 and 3, PSL-2 (13.2)**

Certification shall be provided by the manufacturer for all product shipped. The requirements of A.9 (SR15) shall apply.

**H.21 Non-metallic seal ring — All groups, PSL-2 (A.8.2)**

Seal rings for field-end box threads shall be shipped separately in a sealed package labelled with the quantity, connection description, connection manufacturer, date inspected, and date packaged.

Table H.1 — Reference table for PSL-2 and PSL-3 requirements

Annex H	ISO 11960	Grades											
		J55	K55	M65	N80 Type 1	N80 Q	L80 Type 1	L80 13Cr	C90	C95	T95	P110	Q125
1	2	3	4	5	6	7	8	9	10	11	12	13	14
H.2.1	6.2.2	2	2										
H.2.2	6.2.2					3							
H.3.1	6.3.4								2		2		
H.3.2	6.3.1 6.3.3									2		2	
H.4.1	7.1								2		2		2
H.4.2	7.1								3		3		
H.5	7.2.3												3
H.6.1	7.3.1				2	2	2		2	2	2	2	2
H.6.2.1	7.5.1 7.5.3 A.10	2	2		2	2	2	2	2	2	2	2	
H.6.2.2	7.5.4 A.7												2
H.7.1	7.10.2						2						
H.7.2	7.10.1								3		3		
H.8	7.12							2					
H.9.1	7.14.1								3		3		
H.9.2	7.14.1							3					
H.10	8.12.7	2	2	2	2	2	2	2	2	2	2	2	2
H.11	9.11	2	2		2	2	2	2	2	2	2	2	2
H.12	9.13.1	2	2		2	2	2	2	2	2	2	2	2
H.13	10.4.3				2	2							
H.14.1	10.6.1 10.6.4 10.6.8					3	3			3		3	3
H.14.2	10.6.5								3		3		
H.15	10.11	2	2	2	2	2	2			2			
H.16	10.12.2	2	2										
H.17.1	10.13.4	2	2	2	2	2	2	2	2	2	2	2	2
H.17.2	10.13.4	3	3	3		3	3	3	3	3	3	3	3
H.18.1.1	10.15.5	2	2										
H.18.1.2	10.15.5 10.15.6			2	2	2							
H.18.1.3	10.15.6						2	2		2			
H.18.1.4	10.15.5 10.15.6	3	3	3									
H.18.1.5	10.15.6 10.15.7 10.15.8					3	3	3		3		3	
H.18.2	10.15.10		2	2									
H.18.3	10.15.12	3	3	3		3	3	3	3	3	3	3	3
H.18.4	10.15.11						2	2	2	2	2	2	2
H.18.5	10.15.11						3	3	3	3	3	3	3
H.19	12.2.1	2	2	2	2	2	2	2	2	2	2	2	2
H.20	13.2	2	2	2	2	2	2	2	2	2	2	2	
H.21	A.8.2	2	2		2	2	2	2	2	2	2	2	2

## Annex I (normative)

### Requirements for thread protector design validation

#### I.1 General

**I.1.1** The design-validation requirements given in this annex pertain to thread protectors that are required for PSL-2 and PSL-3 of this International Standard for tubular products with API or SF threaded connections. These protectors are typically composite-type metal-plastic; composite-type plastic, or all-plastic construction; they have a plastic-type thread profile to prevent galling and a reinforced outer shell to resist impact loads. The thread protector shall be designed to comply with 12.2 and the testing specified in this annex.

**I.1.2** The thread-protector manufacturer shall document the design criteria, evaluation data and installation procedures to demonstrate compliance with these requirements. This information shall be available upon request to both the protector purchaser and/or the tubular user.

**I.1.3** The thread-protector manufacturer shall design the protector to be used in conjunction with API and/or SF thread forms. Thread-protector design shall assist in minimizing corrosion that can result from moisture intrusion or entrapment. The protectors shall be capable of a snug-up fit with the face of the pin or coupling as applicable (no gap). The use of a gasket-type insert in the pin-end protector is acceptable by agreement between the manufacturer and purchaser.

**I.1.4** The protector shall be designed to operate in the temperature range of  $-46\text{ }^{\circ}\text{C}$  ( $-50\text{ }^{\circ}\text{F}$ ) to  $66\text{ }^{\circ}\text{C}$  ( $150\text{ }^{\circ}\text{F}$ ). The tolerance for all test temperatures shall be  $\pm 6\text{ }^{\circ}\text{C}$  ( $\pm 10\text{ }^{\circ}\text{F}$ ).

**I.1.5** The thread profile shall be made of a material that will prevent galling of both the pin and box threads. It shall have sufficient thread contact to ensure performance. There shall be no metal-to-metal contact on the connection thread form or metal-to-metal seal surface.

**I.1.6** All plastic shall be either compounded or protected against deterioration from ultraviolet light for not less than one year. This may be accomplished by either chemical additions to the plastic or mechanical methods that limit exposure to this type of radiation.

**I.1.7** The protector shall not be affected by solvents (such as diesel fuel, acetone, varsol, trichloroethylene), storage or assembly-thread compounds.

**I.1.8** Air entrapment in the plastic material during moulding shall be minimized. This should be controlled by the manufacturing process. At least 90 % of any one thread shall remain where air entrapment voids do occur, and no continuous line of broken threads shall cross the seal area or perfect-thread area.

**I.1.9** If hookable/liftable thread protectors are specified, the protectors shall be made in such a way to preclude contact between lift hooks and pipe ends or the threaded portion of the box.

#### I.2 Validation procedure

The following validation procedure determines the suitability for service of thread protectors. The protector manufacturer shall test a minimum of two sizes of tubing and two sizes of casing that define the size range offered by the manufacturer for each of the manufacturer's design types. The manufacturer shall provide objective evidence that pipe sizes tested are the worst case for his design. Justification for extrapolation to non-tested sizes shall be provided.

### I.3 Sample identification

Hereafter, the protector/connector sets are referred to as “test-piece sets”. Each protector and connector set shall be identified with a unique identifier (pin and box).

### I.4 Dimensional stability tests

**I.4.1** Measure and record the thread diameters and seal diameters (where applicable) on the test-piece sets at 21 °C (70 °F). Test-piece sets that do not meet the manufacturer's design criteria shall be rejected.

**I.4.2** Using appropriate temperature bath(s), soak test-piece sets at – 46 °C (– 50 °F), 66 °C (150 °F) and 21 °C (70 °F). Remove from the bath and immediately record the thread diameters and seal diameters (where applicable) of the test-piece sets.

**I.4.3** Restabilize the test-piece sets at 21 °C (70 °F). Measure and record the thread diameters and the seal diameters (where applicable) of the protectors and connectors. Changes in thread diameter resulting in thread engagement of less than one-half the specified thread height per side shall be unacceptable throughout the design temperature range.

### I.5 Torque and vibration tests

**I.5.1** The pin and box-thread protector shall be self-locking and able to withstand vibrations encountered during transportation. Refer to manufacturer's procedures for torque requirements to seat and remove protectors.

**I.5.2** Make up test sets (with storage compound and/or thread compound applied to machined threaded area of a connection) by applying the protectors to the connections using the protector manufacturer's recommended practice, and record the make-up torque.

**I.5.3** Stabilize made-up test-piece sets at – 46 °C (– 50 °F), 66 °C (150 °F) and 21 °C (70 °F). Break out the protector from the connection and record the torque.

**I.5.4** Protectors that are incapable of meeting the manufacturer's required installation torque (or with stripping, disengaging and not shouldering the threads of the protector) shall not be considered acceptable for service.

**I.5.5** Using test-piece sets made up to manufacturer's installation procedure, perform vibration testing in accordance with MIL-STD-810.

**I.5.6** The protector shall not fall off or out during a one-million-cycle test. The test shall be conducted at a minimum of 900 r/min with a minimum vertical displacement of 8,4 mm (0.33 in) and a minimum acceleration of four times gravitational acceleration.

### I.6 Axial impact tests

**I.6.1** Make up test-piece sets (with appropriate storage compound and/or thread compound) by applying the protectors to the connectors using the protector manufacturer's recommended practice and record torque.

**I.6.2** Stabilize test-piece sets at – 46 °C (– 50 °F), 66 °C (150 °F) and 21 °C (70 °F).

**I.6.3** Subject the test-piece sets to the axial impact test (see Figure D.27) at the stabilized temperatures using a steel bar of 38 mm (1.5 in) diameter and a minimum free fall height of 0,3 m (12 in). The thread protectors (pin and box) shall be capable of sustaining the axial impact loads in Table I.1 without damage to the machined surfaces of pipe pin or box threads.

**Table I.1 — Axial impact test using 38 mm (1.5 in) diameter steel bar**

Test temperature °C (°F)	Minimum impact energy joules (foot-pounds)		
	Label 1: ≤ 3-1/2	Label 1: > 3-1/2 to 8-3/4	Label 1: > 8-3/4
1	2	3	4
66 (150)	407 (300)	1627 (1200)	2034 (1500)
21 (70)	407 (300)	1627 (1200)	2034 (1500)
– 46 (– 50)	230 (170)	814 (600)	1085 (800)

## I.7 Angular impact test

**I.7.1** Make up test piece sets (with storage compound and/or thread compound) by applying the protectors to the connections using the protector manufacturer's recommended practice and record make-up torque.

**I.7.2** Stabilize made-up test-piece sets at – 46 °C (– 50 °F), 66 °C (150 °F) and 21 °C (70 °F).

**I.7.3** Apply a 45° angular impact load (see Figure D.28) to the test-piece sets at the stabilized temperatures using a flat steel plate and a minimum free fall height of 0,3 m (12 in.). The thread protectors (pin and box) shall be capable of sustaining angular impact loads in Table I.2 without damage to the tubular's pin and box machined surfaces.

**Table I.2 — Angular (45°) impact test using a flat steel plate**

Test temperature °C (°F)	Minimum impact energy joules (foot-pounds)		
	Label 1: ≤ 3-1/2	Label 1: > 3-1/2 to 8-3/4	Label 1: > 8-3/4
1	2	3	4
66 (150)	203 (150)	814 (600)	1017 (750)
21 (70)	203 (150)	814 (600)	1017 (750)
– 46 (– 50)	115 (85)	407 (300)	542 (400)

## I.8 Corrosion test

**I.8.1** The protector shall assist in the prevention of corrosion of the thread and sealing surfaces. Proper sealing, venting and use of corrosion-inhibiting compounds are essential to minimize corrosion. The normal storage period shall be one year, as described in 12.2.1.

**I.8.2** The salt-water spray test in accordance with ASTM B117 has been demonstrated to determine corrosion resistance for comparison purposes. The salt-spray test may not duplicate actual field use due to factors other than thread-protector performance.

**I.8.3** Make up test-piece sets (with storage compound and/or thread compound) by applying protectors to the connection using the protector manufacturer's recommended practice, and record the make-up torque.

**I.8.4** The cut-off end of the connector shall be sealed and vented with a hole to allow chamber atmosphere circulation.

**I.8.5** Conduct a salt-spray test in accordance with ASTM B117 for a minimum of 1 000 h at a temperature of 35 °C (95 °F).

**I.8.6** Orient the test-piece sets in the test chamber to simulate pipe rack storage.

**I.8.7** The protectors shall be deemed to have passed the test if there is

- no or slight corrosion damage in the seal and the perfect thread area, and
- less than 10 % corrosion damage of the overall thread surface.

## **I.9 Stripping test (pin end only)**

**I.9.1** Make up test-piece sets (with storage compound and/or thread compound) by applying protectors to the connector using the protector manufacturer's recommended practice, and record the make-up torque.

**I.9.2** Stabilize made-up test-piece sets at – 46 °C (– 50 °F), 66 °C (150 °F) and 21 °C (70 °F).

**I.9.3** Conduct a stripping test in accordance with IADC/SPE 11396 on the pin protector (see Figure D.29) at the required stabilized temperatures and with an axial load equal to or greater than  $F_{ax}$ :

$$F_{ax} = 0,18 \times w_m$$

where

$F_{ax}$  is the force, expressed in kilonewtons;

$w_m$  is the linear mass of the pipe, expressed in kilograms per metre;

or

$$F_{ax} = 60 \times w$$

where

$F_{ax}$  is the force, expressed in pounds force;

$w$  is the linear mass of the pipe, expressed in pounds per foot.

**I.9.4** Remove the protectors and inspect for torn threads. Protector threads may show signs of stress but shall not be torn away.

## **I.10 Hookability (liftability) test**

When a hookable (liftable) thread protector is required, the manufacturer shall demonstrate the hookability (liftability) of the design. The hookability (liftability) shall be evaluated on the basis of no damage to the pin-end or box-end of the connector. The type of hook used for the test shall be documented.



## Annex J (informative)

### Summary of Product Specification Level (PSL) requirements

#### J.1 General

**J.1.1** This annex is provided for the convenience of the user of this specification and identifies the additional requirements when product is ordered to PSL-2 or PSL-3.

**J.1.2** Requirements are given in the subclauses indicated in square brackets [ ] after each item.

#### J.2 PSL-2 requirements

##### J.2.1 All grades except H40

**J.2.1.1** Mandatory CVN impact testing and requirements (according to SR 16) [H.6.2.1].

NOTE This is a PSL-1 requirement for Grades M65 and Q125.

**J.2.1.2** No product to be susceptible to having material detach during make-up (appropriate processing or abrasive blasting [H.10 and H.12]).

**J.2.1.3** Seal-ring groove machining and tolerances [H.11].

**J.2.1.4** Metallographic examination of the weld zone [H.15].

NOTE This is a PSL-1 requirement for Grades P110 and Q125, and there is no EW Grade L80 13CR, C90, or T95.

**J.2.1.5** Wall thickness measurement (25 % coverage) [H.17.1].

**J.2.1.6** Thread protectors shall be qualified to Annex I requirements [H.19].

**J.2.1.7** Certification to SR 15 (with heat and lot traceability) [H.20].

**J.2.1.8** Seal ring to be shipped separately [H.21].

##### J.2.2 Grades J55 and K55

**J.2.2.1** Full-body heat treatment (after upsetting if applicable) [H.2.1].

**J.2.2.2** Alternative test pressures for Label 1 larger than 9-5/8 [H.16].

**J.2.2.3** NDE for longitudinal internal and external defects with a 12,5 % notch [H.18.1.1].

**J.2.2.4** For K55 only: ultrasonic testing of the weld seam after hydrostatic test [H.18.2].

##### J.2.3 Grade M65

**J.2.3.1** NDE for longitudinal and transverse, internal and external defects with a 10 % notch (no MPI) [H.18.1.2].

**J.2.3.2** Ultrasonic testing of the weld seam after hydrostatic test [H.18.2].

#### **J.2.4 Grades N80 Type 1 and N80Q**

**J.2.4.1** CVN impact shear area requirement of 75 % shear [H.6.1].

**J.2.4.2** Tensile test frequency as for Grade L80 [H.13].

**J.2.4.3** NDE for longitudinal and transverse, internal and external defects with a 10 % notch (no MPI) [H.18.1.2].

#### **J.2.5 Grade L80 Type 1**

**J.2.5.1** CVN impact shear area requirement of 75 % shear [H.6.1].

**J.2.5.2** Minimum martensite content of 90 % (based on a minimum Rockwell C-scale hardness for an as-quenched sample) [H.7.1].

**J.2.5.3** NDE for longitudinal and transverse, internal and external defects with a 5 % notch, on pipe [H.18.1.3].

**J.2.5.4** NDE for coupling stock [H.18.4].

#### **J.2.6 Grade L80 13Cr**

**J.2.6.1** Inside surface preparation [H.8].

**J.2.6.2** NDE for longitudinal and transverse, internal and external defects with a 5 % notch, on pipe [H.18.1.3].

**J.2.6.3** NDE for coupling stock [H.18.4].

#### **J.2.7 Grades C90 and T95**

**J.2.7.1** Hot-straightening requirement with a minimum temperature or cold-straightening followed by stress relief [H.3.1].

**J.2.7.2** Type 1 chemical composition required [H.4.1].

**J.2.7.3** CVN impact shear area requirement of 75 % shear [H.6.1].

**J.2.7.4** NDE for coupling stock [H.18.4].

#### **J.2.8 Grade C95**

**J.2.8.1** Hot-straightening requirement with a minimum temperature or cold-straightening followed by stress relief [H.3.2].

**J.2.8.2** CVN impact shear area requirement of 75 % shear [H.6.1].

**J.2.8.3** NDE for longitudinal and transverse, internal and external defects with a 5 % notch, on pipe [H.18.1.3].

**J.2.8.4** NDE for coupling stock [H.18.4].

**J.2.9 Grade P110**

**J.2.9.1** Hot-straightening requirement with a minimum temperature or cold-straightening followed by stress relief [H.3.2].

**J.2.9.2** CVN impact shear area requirement of 75 % shear [H.6.1].

**J.2.9.3** NDE for coupling stock [H.18.4].

**J.2.10 Grade Q125**

**J.2.10.1** Type 1 chemical composition required [H.4.1].

**J.2.10.2** CVN impact shear area requirement of 75 % shear [H.6.1].

**J.2.10.3** Statistical impact testing according to SR 12 [H.6.2.2].

**J.2.10.4** NDE for coupling stock [H.18.4].

**J.3 PSL-3 requirements****J.3.1 General**

In addition to those requirements for PSL-2, PSL-3 has further requirements as described in the following sub-clauses.

**J.3.2 All Grades except H40 and N80 Type 1**

**J.3.2.1** Wall thickness measurement with 100 % coverage, report the minimum wall thickness [H.17.2].

**J.3.2.2** Wet MPI of threaded ends required before make-up [H.18.3].

**J.3.3 All Grades except Group 1**

NDE for coupling stock [H.18.5].

**J.3.4 Grades J55, K55 and M65**

NDE for longitudinal and transverse, internal and external, defects with a 5 % notch (no MPI) [H.18.1.4].

**J.3.5 Grades N80Q, L80 Type 1, C95 and P110**

**J.3.5.1** Surface hardness test of each pipe body, upset end and coupling [H.14.1].

**J.3.5.2** NDE: mandatory ultrasonic test plus one other method [H.18.1.5].

**J.3.6 Grade L80 13Cr**

**J.3.6.1** SSC test: using ANSI-NACE TM0177:1996, Method A, demonstrate a threshold stress of 80 % of the specified minimum yield stress in a test solution with pH 3,5 and a hydrogen sulfide partial pressure of 10 kPa (1.5 psi) [H.9.2].

**J.3.6.2** NDE: mandatory ultrasonic test plus EMI for the outside surface [H.18.1.5].

### **J.3.7 Grades C90 and T95**

**J.3.7.1** Agreement on chemical composition [H.4.2].

**J.3.7.2** Minimum martensite content of 95 % (based on a minimum Rockwell C-scale hardness for an as-quenched sample) [H.7.2].

**J.3.7.3** SSC test: using ANSI-NACE TM0177:1996, Method A, test three pipes per heat at an applied stress of 90 % of the specified minimum yield stress [H.9.1].

**J.3.7.4** Hardness test of both ends of each pipe [H.14.2].

### **J.3.8 Grade Q125**

**J.3.8.1** Maximum yield strength of 965 MPa (140 ksi) specified [H.5].

**J.3.8.2** Surface hardness test of each pipe body, upset and coupling [H.14.1].

## Bibliography

- [1] Failure Analysis and Prevention, *ASM Metals Handbook*, Volume 11, 9<sup>th</sup> edition, 1986
- [2] J.M. HODGE and M.A. OREHOSKI, Relationship between hardenability and percentage martensite in some low alloy steels. *Trans. AIME*, **167**, 1946, pp. 627-642
- [3] API Bull 5A2, *Bulletin on Thread Compounds for Casing, Tubing, and Line Pipe*, sixth edn, May 31, 1988
- [4] API Spec 5CT, *Specification for Casing and Tubing* Seventh Edition; ISO 11960:2001; Supersedes Spec 5CT Metric/ISO 11960 Adoption
- [5] National Bureau of Standards, Handbook 91, *U.S. Department of Commerce, Experimental Statistics*
- [6] API RP 5A3, *Recommended Practice On Thread Compounds For Casing, Tubing And Line Pipe*
- [7] API RP 5C1, *Recommended Practice for Care and Use of Casing and Tubing*

.....



**American Petroleum Institute  
2005 Publications Order Form**

Effective January 1, 2005.

API Members receive a 30% discount where applicable.

The member discount does not apply to purchases made for the purpose of resale or for incorporation into commercial products, training courses, workshops, or other commercial enterprises.

Available through Global Engineering Documents:

**Phone Orders: 1-800-854-7179** (Toll-free in the U.S. and Canada)  
**303-397-7956** (Local and International)

**Fax Orders: 303-397-2740**

**Online Orders: www.global.ihs.com**

Date: \_\_\_\_\_

**API Member** (Check if Yes)

**Invoice To** ( Check here if same as "Ship To")

Name: \_\_\_\_\_  
 Title: \_\_\_\_\_  
 Company: \_\_\_\_\_  
 Department: \_\_\_\_\_  
 Address: \_\_\_\_\_  
 \_\_\_\_\_  
 City: \_\_\_\_\_ State/Province: \_\_\_\_\_  
 Zip/Postal Code: \_\_\_\_\_ Country: \_\_\_\_\_  
 Telephone: \_\_\_\_\_  
 Fax: \_\_\_\_\_  
 E-Mail: \_\_\_\_\_

**Ship To** (UPS will not deliver to a P.O. Box)

Name: \_\_\_\_\_  
 Title: \_\_\_\_\_  
 Company: \_\_\_\_\_  
 Department: \_\_\_\_\_  
 Address: \_\_\_\_\_  
 \_\_\_\_\_  
 City: \_\_\_\_\_ State/Province: \_\_\_\_\_  
 Zip/Postal Code: \_\_\_\_\_ Country: \_\_\_\_\_  
 Telephone: \_\_\_\_\_  
 Fax: \_\_\_\_\_  
 E-Mail: \_\_\_\_\_

Quantity	Product Number	Title	SO★	Unit Price	Total

**Payment Enclosed**       **P.O. No.** (Enclose Copy) \_\_\_\_\_

**Charge My Global Account No.** \_\_\_\_\_

**VISA**     **MasterCard**     **American Express**     **Diners Club**     **Discover**

Credit Card No.: \_\_\_\_\_

Print Name (As It Appears on Card): \_\_\_\_\_

Expiration Date: \_\_\_\_\_

Signature: \_\_\_\_\_

<b>Subtotal</b>
<b>Applicable Sales Tax</b> (see below)
<b>Rush Shipping Fee</b> (see below)
<b>Shipping and Handling</b> (see below)
<b>Total (in U.S. Dollars)</b>

★ To be placed on **Standing Order** for future editions of this publication, place a check mark in the SO column and sign here:

**Pricing and availability subject to change without notice.**

**Mail Orders** – Payment by check or money order in U.S. dollars is required except for established accounts. State and local taxes, \$10 processing fee\*, and 5% shipping must be added. Send mail orders to: **API Publications, Global Engineering Documents, 15 Inverness Way East, M/S C303B, Englewood, CO 80112-5776, USA.**

**Purchase Orders** – Purchase orders are accepted from established accounts. Invoice will include actual freight cost, a \$10 processing fee\*, plus state and local taxes.

**Telephone Orders** – If ordering by telephone, a \$10 processing fee\* and actual freight costs will be added to the order.

**Sales Tax** – All U.S. purchases must include applicable state and local sales tax. Customers claiming tax-exempt status must provide Global with a copy of their exemption certificate.

**Shipping** (U.S. Orders) – Orders shipped within the U.S. are sent via traceable means. Most orders are shipped the same day. Subscription updates are sent by First-Class Mail. Other options, including next-day service, air service, and fax transmission are available at additional cost. Call 1-800-854-7179 for more information.

**Shipping** (International Orders) – Standard international shipping is by air express courier service. Subscription updates are sent by World Mail. Normal delivery is 3-4 days from shipping date.

**Rush Shipping Fee** – Next Day Delivery orders charge is \$20 in addition to the carrier charges. Next Day Delivery orders must be placed by 2:00 p.m. MST to ensure overnight delivery.

**Returns** – All returns must be pre-approved by calling Global's Customer Service Department at 1-800-624-3974 for information and assistance. There may be a 15% restocking fee. Special order items, electronic documents, and age-dated materials are non-returnable.

**\*Minimum Order** – There is a \$50 minimum for all orders containing hardcopy documents. The \$50 minimum applies to the order subtotal including the \$10 processing fee, excluding any applicable taxes and freight charges. If the total cost of the documents on the order plus the \$10 processing fee is less than \$50, the processing fee will be increased to bring the order amount up to the \$50 minimum. This processing fee will be applied before any applicable deposit account, quantity or member discounts have been applied. There is no minimum for orders containing only electronically delivered documents.

# There's more where this came from.

The American Petroleum Institute provides additional resources and programs to the oil and natural gas industry which are based on API® Standards. For more information, contact:

- API Monogram® Licensing Program Phone: 202-962-4791  
Fax: 202-682-8070
- American Petroleum Institute Quality Registrar (APIQR®) Phone: 202-962-4791  
Fax: 202-682-8070
- API Spec Q1® Registration Phone: 202-962-4791  
Fax: 202-682-8070
- API Perforator Design Registration Phone: 202-962-4791  
Fax: 202-682-8070
- API ISO/TS 29001 Registration Phone: 202-962-4791  
Fax: 202-682-8070
- API Training Provider Certification Program Phone: 202-682-8490  
Fax: 202-682-8070
- Individual Certification Programs Phone: 202-682-8064  
Fax: 202-682-8348
- Engine Oil Licensing and Certification System (EOLCS) Phone: 202-682-8516  
Fax: 202-962-4739
- API PetroTEAM™ (Training, Education and Meetings) Phone: 202-682-8195  
Fax: 202-682-8222

Check out the API Publications, Programs, and Services Catalog online at [www.api.org](http://www.api.org).



Helping You Get  
The Job Done Right.®



www.ihsonline.com

Additional copies are available through Global Engineering Documents at (800) 854-7179 or (303) 397-7956

Information about API Publications, Programs and Services is available on the World Wide Web at <http://www.api.org>



1220 L Street, Northwest  
Washington, D.C. 20005-4070  
202-682-8000

Product No: GX5CT08