

PowerFlex 40 Configured AC Drives

Catalog Numbers 23B



Important User Information

Solid-state equipment has operational characteristics differing from those of electromechanical equipment. Safety Guidelines for the Application, Installation and Maintenance of Solid State Controls (publication [SGI-1.1](#) available from your local Rockwell Automation® sales office or online at <http://www.rockwellautomation.com/literature/>) describes some important differences between solid-state equipment and hard-wired electromechanical devices. Because of this difference, and also because of the wide variety of uses for solid-state equipment, all persons responsible for applying this equipment must satisfy themselves that each intended application of this equipment is acceptable.

In no event will Rockwell Automation, Inc. be responsible or liable for indirect or consequential damages resulting from the use or application of this equipment.

The examples and diagrams in this manual are included solely for illustrative purposes. Because of the many variables and requirements associated with any particular installation, Rockwell Automation, Inc. cannot assume responsibility or liability for actual use based on the examples and diagrams.

No patent liability is assumed by Rockwell Automation, Inc. with respect to use of information, circuits, equipment, or software described in this manual.

Reproduction of the contents of this manual, in whole or in part, without written permission of Rockwell Automation, Inc., is prohibited.

Throughout this manual, when necessary, we use notes to make you aware of safety considerations.



WARNING: Identifies information about practices or circumstances that can cause an explosion in a hazardous environment, which may lead to personal injury or death, property damage, or economic loss.



ATTENTION: Identifies information about practices or circumstances that can lead to personal injury or death, property damage, or economic loss. Attentions help you identify a hazard, avoid a hazard, and recognize the consequence.



SHOCK HAZARD: Labels may be on or inside the equipment, for example, a drive or motor, to alert people that dangerous voltage may be present.



BURN HAZARD: Labels may be on or inside the equipment, for example, a drive or motor, to alert people that surfaces may reach dangerous temperatures.

IMPORTANT

Identifies information that is critical for successful application and understanding of the product.

Allen-Bradley, Rockwell Software, Rockwell Automation, and PowerFlex are trademarks of Rockwell Automation, Inc.

Trademarks not belonging to Rockwell Automation are property of their respective companies.

	Preface	
Overview	Who Should Use this Manual?	5
	What Is Not in this Manual	5
	Reference Materials	6
	Manual Conventions	6
	General Precautions	7
	Compliance Certification	7
	Catalog Number Explanation	8
	Chapter 1	
PowerFlex 40 Standard Configured Drive Standard Features and Options	Chapter Objectives	9
	Standard Features	9
	Enclosure Options	10
	Communication Options	11
	Power Disconnect Options	12
	Operator Device Options	17
	Quick Disconnects	23
	I/O Options	24
	Chapter 2	
Control Wiring Overview	Chapter Objectives	27
	Control Wiring Overview	27
	Schematic Drawings	28
	Chapter 3	
Mechanical Installation	Chapter Objectives	49
	Mounting Considerations	49
	Dimensions	50
	Layout Drawings	52
	Appendix A	
	Specifications	
	Appendix B	
	Replacement Parts	

Overview

The purpose of this manual is to provide basic information needed to install PowerFlex 40 Adjustable Frequency AC Standard Configured Drives.

User documentation for the PowerFlex 40 Standard Configured Drives includes these Installation Instructions and the PowerFlex 40 User Manual, publication [22B-UM001](#). Both manuals are required to properly install and operate PowerFlex 40 Adjustable Frequency AC Standard Configured Drives.

For information on ...	See page ...
Who Should Use this Manual?	5
What Is Not in this Manual	5
Reference Materials	6
Manual Conventions	6
General Precautions	7
Compliance Certification	7
Catalog Number Explanation	8

Who Should Use this Manual?

This manual is intended for qualified personnel. You must be able to program and operate Adjustable Frequency AC Drive devices. In addition, you must have an understanding of the parameter settings and functions.

What Is Not in this Manual

The PowerFlex 40 Adjustable Frequency AC Standard Configured Drives Installation Instructions is designed to provide only basic installation and operation information. For this reason, the following topics have not been included:

- Troubleshooting
- Start-Up
- Programming and Parameters

Please refer to the PowerFlex 40 User Manual, publication [22B-UM001](#), for detailed drive information.

Reference Materials

The following manuals are recommended for general drive information:

Title	Publication	Available Online at ...
Wiring and Grounding Guidelines for Pulse Width Modulated (PWM) AC Drives	DRIVES-IN001	www.rockwellautomation.com/literature
Preventive Maintenance of Industrial Control and Drive System Equipment	DRIVES-TD001	
Safety Guidelines for the Application, Installation and Maintenance of Solid State Control	SGI-1.1	
A Global Reference Guide for Reading Schematic Diagrams	0100-2.10	
Guarding Against Electrostatic Damage	8000-4.5.2	

For detailed PowerFlex 40 information including drive parameters, programming, start-up, troubleshooting, specifications:

Title	Publication	Available Online at ...
PowerFlex 40 User Manual	22B-UM001	www.rockwellautomation.com/literature
PowerFlex Reference Manual	PFLEX-RM001	

The latest version of this Installation Instructions can be obtained online at ... www.rockwellautomation.com/literature

For Allen-Bradley Drives Technical Support:

Title	Online at ...
Allen-Bradley Drives Technical Support	www.ab.com/support/abdrives

Manual Conventions

- To help differentiate parameter names and LCD display text from other text, the following conventions will be used:
 - Parameter Names will appear in [brackets].
For example: [DC Bus Voltage].
 - Display Text will appear in “quotes.” For example: “Enabled.”
- The following words are used throughout the manual to describe an action:

Word	Meaning
Can	Possible, able to do something
Cannot	Not possible, not able to do something
May	Permitted, allowed
Must	Unavoidable, you must do this
Shall	Required and necessary
Should	Recommended
Should Not	Not recommended

General Precautions



ATTENTION: This drive contains ESD (Electrostatic Discharge) sensitive parts and assemblies. Static control precautions are required when installing, testing, servicing or repairing this assembly. Component damage may result if ESD control procedures are not followed. If you are not familiar with static control procedures, reference A-B publication 8000-4.5.2, "Guarding Against Electrostatic Damage" or any other applicable ESD protection handbook.



ATTENTION: An incorrectly applied or installed drive can result in component damage or a reduction in product life. Wiring or application errors, such as, under sizing the motor, incorrect or inadequate AC supply, or excessive ambient temperatures may result in malfunction of the system.



ATTENTION: Only qualified personnel familiar with adjustable frequency AC drives and associated machinery should plan or implement the installation, start-up and subsequent maintenance of the system. Failure to comply may result in personal injury and/or equipment damage.



ATTENTION: To avoid an electric shock hazard, verify that the voltage on the bus capacitors has discharged before performing any work on the drive. Measure the voltage at the drive (Refer to the PowerFlex 40 User Manual for test point locations). The voltage must be zero.

Compliance Certification

Certifications are applicable to approved program defined options.

U.S./Canada	UL:	UL508C
	CUL:	CAN/CSA-C22.2 No. 14

Please refer to the PowerFlex 40 User Manual, publication [22B-UM001](#), for additional information.

Catalog Number Explanation

The PowerFlex 40 Adjustable Frequency AC Standard Configured Drives catalog numbering scheme is shown below.

1-3			4	5	6-8			Position				13	14	15	16+
23B			-	D	4P0			D	1	0	4	N	N	-	P6
<i>a</i>				<i>b</i>	<i>c</i>			<i>d</i>	<i>e</i>	<i>f</i>	<i>g</i>	<i>h</i>	<i>i</i>		<i>j</i>
a															
Drive															
Code	Type														
23B	PowerFlex 40														
b															
Voltage Rating															
Code	Voltage	Ph.													
D	480V ac	3													
c															
Amp Rating															
480V 60Hz Input															
Code	Amps	kW (Hp)													
1P4	1.4	0.4 (0.5)													
2P3	2.3	0.75 (1.0)													
4P0	4.0	1.5 (2.0)													
6P0	6.0	2.2 (3.0)													
010	10.5	4.0 (5.0)													
012	12	5.5 (7.5)													
017	17	7.5 (10)													
024	24	11 (15)													
d															
Enclosure															
Code	Enclosure														
C	NEMA/UL Type 4X ‡														
D	NEMA/UL Type 4 ‡														
‡ The design of the PowerFlex 40 Standard Configured Drive supports indoor and outdoor applications that are not in direct sunlight.															
e															
HIM															
Code	Interface Module														
1	Fixed Keypad on Drive														
F †	Fixed Keypad on Drive and LCD Display with Digital Speed Control HIM on Enclosure Door (22-HIM-C2S)														
† This option changes the enclosure rating to indoor only.															
f															
Emission Class															
Code	Rating														
0	Not Filtered														
g															
Version															
Code	Version														
4	RS485 (Standard)														
C	ControlNet														
D	DeviceNet														
E	EtherNet/IP														
P	PROFIBUS DP														
h															
Rating															
Code	Rating														
N	Reserved														
i															
Rating															
Code	Rating														
N	Reserved														
j															
Options															
Code	Description														
-E22	DeviceNet Quick Disconnect (Bottom)														
-E23	DeviceNet Quick Disconnect (Left Side)														
-P3	Motor Circuit Protector														
-P3T	Motor Circuit Protector (Customer wiring into top of device)														
-P6	Disconnect Switch - Fused														
-P6T	Disconnect Switch - Fused (Customer wiring into top of device)														
-R3	DeviceNet I/O (4 In/2 Out) w/Spring Return HOA and Power Disconnect Aux. Contact														
-R4	DeviceNet Point I/O w/IB4 (4 Inputs)														
-R5	-R3 plus 4 I/O Quick Disconnects and (1) 24V DC Receptacle														
-S1	Hand/Off/Auto S.S. (Start/Stop/Speed Ref.)														
-S4	Auto/Manual S.S. (Speed Ref.)														
-S7	Start and Stop P.B.														
-S8	Forward/Reverse S.S.														
-S18	Door Mounted Local Speed Pot (1-Turn)														
-S20	Local/Remote and Local Control Off/Run Forward Selector Switches														
-S21	Local/Off/Remote with 1 N.O. Interposing Relay														
-S22	Spring Return Hand/Off Auto S.S. (Start/Stop/Speed Ref.)														
-S23	Clear Fault P.B.														

PowerFlex 40 Standard Configured Drive Standard Features and Options

Chapter Objectives

This chapter describes the standard features and operation for PowerFlex 40 Standard Configured Drives and associated options.

For information on ...	See page ...
Standard Features	9
Enclosure Options	10
Communication Options	11
Power Disconnect Options	12
Operator Device Options	17
Quick Disconnects	23
I/O Options	24

Standard Features

This package integrates the Standard PowerFlex 40 drive. The PowerFlex 40 drive can be used for Volts per hertz or Sensorless Vector applications and offers an Autotune feature allowing the drive to adapt to individual motor characteristics.

The PowerFlex 40 is assembled in an enclosure which includes the following features.

- NEMA/UL Type 4/4X - indoor and outdoor applications other than direct sunlight. ⁽¹⁾
- Flange mount drive/external heatsink reducing overall enclosure size.
- Mounting feet - orientation is adjustable per customer requirements.

If required, the drive can be removed from the front of the enclosure for ease of assembly or repair.

Low cost, highly configurable I/O inputs and/or 0-10V/4-20 mA outputs that are not used by program standard features and options are available for customer use.

(1) The enclosure does not normally protect electrical equipment from condensation, corrosion or contamination, which may occur within the enclosure or enter via the conduit or unsealed openings. Users must make adequate provisions to safeguard against such conditions, and satisfy themselves that the equipment is properly protected. For further information on criteria associated with NEMA enclosure ratings, refer to NEMA standards Publication No. 250-1991. When optional Door Mounted HIM is supplied, enclosure is rated indoor only. See enclosure options for specific enclosure style quoted.

Enclosure Options

NEMA/UL Type 4 (Position 9, Code D)

The enclosure provided is a NEMA/UL Type 4, painted mild steel, which supports both NEMA/UL Type 4 and NEMA/UL Type 12 applications. Type 4 enclosures are intended for indoor or outdoor use primarily to provide a degree of protection against windblown dust and rain, splashing water, and hose directed water, and to be undamaged by the formation of ice on the enclosure. They are designed to meet hose-down, dust, and external icing and rust resistance design tests. Doors and openings will be gasket sealed. There are no ventilation openings within the enclosure to allow for free exchange of inside and outside air.

Note: If optional Door Mounted HIM is not supplied, the design of the PowerFlex 40 Standard Configured Drive supports indoor and outdoor applications that are not in direct sunlight.

NEMA/UL Type 4X (Position 9, Code C)

The enclosure provided is a NEMA/UL Type 4X. The material is type 304 stainless steel. Type 4X enclosures are intended for indoor or outdoor use primarily to provide a degree of protection against corrosion, windblown dust and rain, splashing water, and hose directed water, and to be undamaged by the formation of ice on the enclosure. They are designed to meet hose-down, dust, and external icing and rust resistance design tests. Doors and openings will be gasket sealed. There are no ventilation openings within the enclosure to allow for free exchange of inside and outside air.

Note: If optional Door Mounted HIM is not supplied, the design of the PowerFlex 40 Standard Configured Drive supports indoor and outdoor applications that are not in direct sunlight.

Communication Options

DeviceNet (Position 12, Code D)

The DeviceNet option is drive mounted and consists of the DeviceNet communication adaptor (22-COMM-D) and adaptor cover (22B-CCB for frame B drives or 22B-CCC for frame C drives). When DeviceNet is present, no other communication option is available other than the HIM. When used as a slave, the HIM will have limited functionality. For details related to the DeviceNet option, refer to the PowerFlex DeviceNet Adaptor User Manual, publication [22COMM-UM003](#).

To review this schematic see [Figure 1 on page 28](#) and [Figure 3 on page 30](#).

EtherNet/IP (Position 12, Code E)

The EtherNet/IP option is drive mounted and consists of the EtherNet/IP communication adaptor (22-COMM-E) and adaptor cover (22B-CCB for frame B drives or 22B-CCC for frame C drives). When EtherNet/IP is present, no other communications option is available other than the HIM. When used as a slave, the HIM will have limited functionality. For details related to the EtherNet/IP option, refer to the PowerFlex EtherNet/IP Adaptor User Manual, publication [22COMM-UM004](#).

To review this schematic see [Figure 1 on page 28](#) and [Figure 3 on page 30](#).

PROFIBUS (Position 12, Code P)

The PROFIBUS option is drive mounted and consists of the PROFIBUS communication adaptor (22-COMM-P) and adaptor cover (22B-CCB for frame B drives or 22B-CCC for frame C drives). When PROFIBUS is present, no other communication option is available other than the HIM. When used as a slave, the HIM will have limited functionality. For details related to PROFIBUS option, refer to the PowerFlex PROFIBUS Adaptor User Manual, publication [22COMM-UM005](#).

To review this schematic see [Figure 1 on page 28](#) and [Figure 3 on page 30](#).

ControlNet (Position 12, Code C)

The ControlNet option is drive mounted and consists of the ControlNet communication adaptor (22-COMM-C) and adaptor cover (22B-CCB for frame B drives or 22B-CCC for frame C drives). When ControlNet is present, no other communication option is available other than the HIM. When used as a slave, the HIM will have limited functionality. For details related to ControlNet option, refer to the PowerFlex ControlNet Adaptor User Manual, publication [22COMM-UM006](#).

To review this schematic see [Figure 1 on page 28](#) and [Figure 3 on page 30](#).

Power Disconnect Options

Drive Motor Circuit Protector (Position 16+, Code -P3)

The Drive Motor Circuit Protector option is factory installed and provides a manual means of disconnecting input power to the drive. The Allen-Bradley Bulletin 140M switch is designed to meet short circuit requirements for branch circuit protection. The rotary style handle is padlockable in On or Off position. This option has a 65 kA short circuit withstand rating. Over load protection is supplied by the drive not the motor circuit protector. Incoming customer supplied power cables terminate at terminals R, S, T (L1, L2, L3) located on the **bottom** of the device.

Component Specifications

Switch	A-B Bulletin 140M, 480V, 65 kA short circuit withstand rating 3-pole, Rod operated UL listed, CE Approved, CSA Certified
Handle	Rotary style handle through the door, Door interlocked Padlockable in On or Off position, Defeatable in the On position IP66 (Type 3R, 3, 12, 4, 4X)

Drive Motor Circuit Protector (Position 16+, Code -P3T)

The Drive Motor Circuit Protector option is factory installed and provides a manual means of disconnecting input power to the drive. The Allen-Bradley Bulletin 140M switch is designed to meet short circuit requirements for branch circuit protection. The rotary style handle is padlockable in On or Off position. This option has a 65 kA short circuit withstand rating. Over load protection is supplied by the drive not the motor circuit protector. Incoming customer supplied power cables terminate at terminals R, S, T (L1, L2, L3) located on the **top** of the device.

Component Specifications

Switch	A-B Bulletin 140M, 480V, 65 kA short circuit withstand rating 3-pole, Rod operated UL listed, CE Approved, CSA Certified
Handle	Rotary style handle through the door, Door interlocked Padlockable in On or Off position, Defeatable in the On position IP66 (Type 3R, 3, 12, 4, 4X)

Drive Input Fused Disconnect Switch (Position 16+, Code -P6)

The Drive Input Fused Disconnect Switch option is factory installed and provides a manual means of disconnecting input power to the drive. The Allen-Bradley Bulletin 194R switch is designed to meet disconnect switch requirements for branch circuit protection. The rotary style handle is padlockable in On or Off position. This option has a 100 kA short circuit withstand rating. Class J fuses are supplied with the disconnect switch. Incoming customer supplied power cables terminate at terminals R, S, T (L1, L2, L3) located on the **bottom** of the device.

Component Specifications

Switch	A-B Bulletin 194R, 600V, 100 kA short circuit withstand rating Integral class J fuses, Captive terminal clamps 3-pole, Rod operated UL listed, CE Approved, CSA, ASTA, and LOVAG Certified
Handle	Rotary style handle through the door, Door interlocked Padlockable in On or Off position, Defeatable in the On position True switch status indication IP66 (Type 3R, 3, 12, 4, 4X)

Drive Input Fused Disconnect Switch (Position 16+, Code -P6T)

The Drive Input Fused Disconnect Switch option is factory installed and provides a manual means of disconnecting input power to the drive. The Allen-Bradley Bulletin 194R switch is designed to meet disconnect switch requirements for branch circuit protection. The rotary style handle is padlockable in On or Off position. This option has a 100 kA short circuit withstand rating. Class J fuses are supplied with the disconnect switch. Incoming customer supplied power cables terminate at terminals R, S, T (L1, L2, L3) located on the **top** of the device.

Component Specifications

Switch	A-B Bulletin 194R, 600V, 100 kA short circuit withstand rating Integral class J fuses, Captive terminal clamps 3-pole, Rod operated UL listed, CE Approved, CSA, ASTA, and LOVAG Certified
Handle	Rotary style handle through the door, Door interlocked Padlockable in On or Off position, Defeatable in the On position True switch status indication IP66 (Type 3R, 3, 12, 4, 4X)

Main Fuses (F1-F3)



ATTENTION: Most codes require that upstream branch circuit protection be provided to protect input power wiring. Install the fuses recommended in [Table 1](#). Do not exceed the fuse ratings. Failure to observe this precaution could result in damage to, or destruction of, the equipment.

Input line branch circuit protection fuses must be used to protect the input power lines. If input fuses are not provided with your drive, recommended fuse values are shown in [Table 1](#). The input fuse ratings listed in [Table 1](#) are applicable for one drive per branch circuit. No other load may be applied to that fused circuit.

The recommended fuse type for all PowerFlex 40 Standard Configured Drives is UL Class J.

Table 1 - Branch Fusing

Voltage Rating	Drive Rating <i>HP</i>	Fuse Rating <i>Amps</i>
480V AC	0.5	3
	1.0	6
	2.0	10
	3.0	15
	5.0	20
	7.5	25
	10	30
	15	50

Input Power Wiring

Refer to the PowerFlex 40 User Manual for additional detailed information about input power wiring recommendations and selection.



ATTENTION: Protect the contents of the options cabinet from metal chips and other debris while drilling the conduit openings. Failure to observe this precaution could result in damage to, or destruction of, the equipment.



ATTENTION: Do not route signal and control wiring with power wiring in the same conduit. This can cause interference with drive operation. Failure to observe this precaution could result in damage to, or destruction of, the equipment.

To connect AC input power to the drive package:

- ❑ 1. Select the proper wire size according to NEC and all applicable local codes and standards. Note that you must punch openings in the Option Cabinet of the desired conduit size, following NEC and all applicable local codes and standards. Power terminal block specifications are listed in [Table 2](#).
- ❑ 2. Connect the three-phase AC input power leads (three-wire VAC) to the appropriate terminals. Connect the AC input power leads to terminals L1, L2, L3 on the fused disconnect switch or motor circuit protector.

Note: Drive Input Fused Disconnect Switch (-P6) and Drive Motor Circuit Protector (-P3) options are bottom fed. Drive Input Fused Disconnect Switch (-P6T) and Drive Motor Circuit Protector (-P3T) options are top fed.

- ❑ 3. Tighten the AC input terminal power terminals to the proper torque according to drive type as shown in [Table 2](#).

Table 2 - Component Current Ratings and Wire Sizing

PowerFlex 40 SPD Drive Rating - 480V				
HP	Continuous Current Rating <i>Amps</i>	Factory Power Wire Size ⁽¹⁾⁽²⁾	Customer Terminal Wire Size	Operating Torque
0.5...3	30	2.5 mm ² (14 AWG)	2.5...8.4 mm ² (14...8 AWG)	1.6 N•m (14 lb•in)
5...7.5	30	3.5 mm ² (12 AWG)	2.5...8.4 mm ² (14...8 AWG)	1.6 N•m (14 lb•in)
10...15	60	4.0 mm ² (10 AWG)	2.5...16.0 mm ² (14...4 AWG)	2.8 N•m (25 lb•in)

(1) Wire is Black Hypalon.

(2) Maximum/minimum sizes that the terminal block will accept - these are not recommendations.

Output Power Wiring

Refer to the PowerFlex 40 User Manual for additional detailed information about output power wiring recommendations and selection.



ATTENTION: Unused wires in conduit must be grounded at both ends to avoid a possible shock hazard caused by induced voltages. Also, if a drive sharing a conduit is being serviced or installed, all drives using this conduit should be disabled to eliminate the possible shock hazard from cross-coupled motor leads. Failure to observe these precautions could result in bodily injury.



ATTENTION: Do not route signal and control wiring with power wiring in the same conduit. This can cause interference with drive operation. Failure to observe this precaution could result in damage to, or destruction of, the equipment.

To connect AC output power wiring from the drive to the motor:

- ❑ 1. Wire the three-phase AC output power motor leads by routing them according to the drive option type. Note that you must punch openings in the option cabinet of the desired conduit size, following NEC and all applicable local codes and standards. Power terminal block specifications are listed in [Table 3](#).

Do not route more than three sets of motor leads through a single conduit. This will minimize cross-talk that could reduce the effectiveness of noise reduction methods. If more than three drive/motor connections per conduit are required, shielded cable must be used. If possible, each conduit should contain only one set of motor leads.

- ❑ 2. Connect the three-phase AC output power motor leads to terminals U, V, W (T1, T2, T3) on the power terminal block located on the drive.
- ❑ 3. Tighten the three-phase AC output power terminals to the proper torque according to drive type as shown in [Table 3](#).

Table 3 - AC Output Power Terminal Block Specifications

Frame	Maximum Wire Size ⁽¹⁾	Minimum Wire Size	Recommended Torque
B	5.3 mm ² (10 AWG)	1.3 mm ² (16 AWG)	1.7...2.2 N•m (16...19 lb•in)
C	8.4 mm ² (8 AWG)	1.3 mm ² (16 AWG)	2.9...3.7 N•m (26...33 lb•in)

(1) Maximum/minimum sizes that the terminal block will accept - these are not recommendations.

Operator Device Options

Hand/Off/Auto Selector Switch (Position 16+, Code S1)

This 800F door mounted operator device is factory installed and provides a Hand/Off/Auto selector switch.

The Hand/Off/Auto selector switch will start the drive in Hand mode and stop the drive in Off mode. In Auto mode the drive will be stopped and started from remote contact closures. In all cases, the Stop input to the drive must be present before the drive will start.

The Hand/Off/Auto selector switch also determines the source of the actual drive speed reference. In Hand mode, speed source is parameter A072 [Preset Freq 2]. In Auto mode, speed source is parameter A071 [Preset Freq 1].

If the door mounted speed potentiometer (Option S18) is supplied and it is intended to be the speed reference in Hand mode, set parameter A052 [Digital In2 Sel] to option 13 "10V In Ctrl." Refer to the table below and the PowerFlex 40 User Manual, publication [22B-UM001](#), for other options.

Hand/Off/Auto Selector Switch (Code S1)

Speed Reference		Parameter Settings		
Hand Mode	Auto Mode	P038 [Speed Reference]	A051 [Digital In1 Sel]	A052 [Digital In2 Sel]
Preset Speed	Preset Speed	4 "Preset Freq"	4 "Preset Freq"	4 "Preset Freq"
	Analog Input (0-10V)	4 "Preset Freq"	13 "10V In Ctrl"	4 "Preset Freq"
	Analog Input (4-20mA)	4 "Preset Freq"	14 "20mA In Ctrl"	4 "Preset Freq"
	Communication Port ⁽¹⁾	4 "Preset Freq"	6 "Comm Port"	4 "Preset Freq"
Speed Pot (Door)	Preset Speed	4 "Preset Freq"	4 "Preset Freq"	13 "10V In Ctrl"
	Analog Input (4-20mA)	4 "Preset Freq"	14 "20mA In Ctrl"	13 "10V In Ctrl"
	Communication Port ⁽¹⁾	4 "Preset Freq"	6 "Comm Port"	13 "10V In Ctrl"
HIM (Door)	Preset Speed	4 "Preset Freq"	4 "Preset Freq"	6 "Comm Port"
	Analog Input (0-10V)	4 "Preset Freq"	13 "10V In Ctrl"	6 "Comm Port"
	Analog Input (4-20mA)	4 "Preset Freq"	14 "20mA In Ctrl"	6 "Comm Port"

(1) Communication port will have both logic and reference control.

Component Specifications

Bulletin 800F Devices	IEC style, Internationally rated Meet IP65/IP66 and NEMA/UL Type 4/4X/13 UL Listed, CSA Certified 10 amp contacts Screw terminals, 0.3...3.5 mm ² (22...12 AWG) maximum
Hand/Off/Auto Selector Switch	3 position, Maintained 4 N.O. contacts
Legend Plate	30 x 50 mm, Black with white lettering
Wiring	0.8 mm ² (18 AWG), Blue
Schematics	Figure 4 on page 31 , Figure 5 on page 32

This option is not compatible with Codes R3, R5, S4, S7, S20, S21 or S22.

Auto/Manual Selector Switch (Position 16+, Code S4)

This 800F door mounted operator device is factory installed and provides an Auto/Manual selector switch.

The Auto/Manual selector switch determines the source of the actual drive speed reference. Using 2-wire control in Auto mode, speed source is parameter A071 [Preset Freq 1]. In Manual mode, the speed source is parameter A072 [Preset Freq 2].

If the door mounted speed potentiometer (Option S18) is supplied and it is intended to be the speed reference in Manual mode, set parameter P052 [Digital In2 Sel] to option 13 "10V In Ctrl." Refer to the table below and the PowerFlex 40 User Manual, publication [22B-UM001](#), for other options.

Auto/Manual Selector Switch (Code S4)

Speed Reference		Parameter Settings		
Manual Mode	Auto Mode	P038 [Speed Reference]	A051 [Digital In1 Sel]	A052 [Digital In2 Sel]
Preset Speed	Preset Speed	4 "Preset Freq"	4 "Preset Freq"	4 "Preset Freq"
	Analog Input (0-10V)	4 "Preset Freq"	13 "10V In Ctrl"	4 "Preset Freq"
	Analog Input (4-20mA)	4 "Preset Freq"	14 "20mA In Ctrl"	4 "Preset Freq"
	Communication Port ⁽¹⁾	4 "Preset Freq"	6 "Comm Port"	4 "Preset Freq"
Speed Pot (Door)	Preset Speed	4 "Preset Freq"	4 "Preset Freq"	13 "10V In Ctrl"
	Analog Input (4-20mA)	4 "Preset Freq"	14 "20mA In Ctrl"	13 "10V In Ctrl"
	Communication Port ⁽¹⁾	4 "Preset Freq"	6 "Comm Port"	13 "10V In Ctrl"
HIM (Door)	Preset Speed	4 "Preset Freq"	4 "Preset Freq"	6 "Comm Port"
	Analog Input (0-10V)	4 "Preset Freq"	13 "10V In Ctrl"	6 "Comm Port"
	Analog Input (4-20mA)	4 "Preset Freq"	14 "20mA In Ctrl"	6 "Comm Port"

(1) Communication port will have both logic and reference control.

Component Specifications

Bulletin 800F Devices	IEC style, Internationally rated Meet IP65/IP66 and NEMA/UL Type 4/4X/13 UL Listed, CSA Certified 10 amp contacts Screw terminals, 0.3...3.5 mm ² (22...12 AWG) maximum
Auto/Manual Selector Switch	2 position, Maintained 1 N.C. contact
Legend Plate	30 x 50 mm, Black with white lettering
Wiring	0.8 mm ² (18 AWG), Blue
Schematics	Figure 6 on page 33 , Figure 7 on page 34 , Figure 8 on page 35

This option is not compatible with Codes R3, R5, S1, S20, S21 or S22.

Start and Stop Push Buttons (Position 16+, Code S7)

This option provides factory installed 800F Start and Stop push buttons.

In all cases, the Stop input to the drive must be present before the drive will start. Using 3-wire control, speed source is parameter A070 [Preset Freq 0]. The Stop push button may also be used as a fault reset.

Component Specifications

Bulletin 800F Devices	IEC style, Internationally rated Meet IP65/IP66 and NEMA/UL Type 4/4X/13 UL Listed, CSA Certified 10 amp contacts Screw terminals, 0.3...3.5 mm ² (22...12 AWG) maximum
Start Push Button	Flush head, Green, 1 N.O. contact
Stop Push Button	Extended head, Red, 1 N.C. contact
Legend Plate	30 x 50 mm, Black with white lettering
Wiring	0.8 mm ² (18 AWG), Blue
Schematics	Figure 7 on page 34 , Figure 9 on page 36 , Figure 10 on page 37

This option is not compatible with Codes R3, R5, S1, S20, S21, S22 or S23.

Forward/Reverse Selector Switch (Position 16+, Code S8)

This 800F door mounted operator device is factory installed and provides a Forward/Reverse selector switch.

When configured for 2-wire control, the drive will start when the selector switch is set to Forward. When the selector switch is set to Reverse, the drive will run in reverse. If the selector switch is operated while the drive is running, a change of direction command will occur. If the drive is stopped and the selector switch is operated, a change of direction command will occur. The speed source is parameter P070 [Preset Freq 0].

When configured for 3-wire control (Code S7 with S8), the selector switch only changes direction. The drive is started and stopped via the Start and Stop push buttons (Code S7).

Component Specifications

Bulletin 800F Devices	IEC style, Internationally rated Meet IP65/IP66 and NEMA/UL Type 4/4X/13 UL Listed, CSA Certified 10 amp contacts Screw terminals, 0.3...3.5 mm ² (22...12 AWG) maximum
Forward/Reverse Selector Switch	2-Wire: 2 position, Maintained, 1 N.O. & 1 N.C. contacts 3-Wire: 2 position, Maintained, 1 N.C. contact
Legend Plate	30 x 50 mm, Black with white lettering
Wiring	0.8 mm ² (18 AWG), Blue
Schematics	2-Wire Control: Figure 5 on page 32 , Figure 8 on page 35 , Figure 11 on page 38 3-Wire Control: Figure 10 on page 37

This option is not compatible with Codes R3, R5, S20 or S21.

Local Speed Potentiometer (Code S18)

This option provides a factory installed 800F door mounted one turn potentiometer for speed control. The device provides the speed source when no digital inputs are active.

When this option is provided, it becomes the speed source for the Hand mode of the Hand/Off/Auto selector switch (Option S1) and the Manual mode of the Auto/Manual selector switch (Option S4).

Component Specifications

Bulletin 800F Devices	IEC style, Internationally rated Meet IP65/IP66 and NEMA/UL Type 4/4X/13 UL Listed, CSA Certified Screw terminals, 0.3...3.5 mm ² (22...12 AWG) maximum
Speed Potentiometer	1-turn, 10k, 2.25W, 500V
Legend Plate	30 x 50 mm, Black with white lettering
Wiring	0.8 mm ² (18 AWG), Blue
Schematic	Figure 13 on page 40

This option is not compatible with Codes R3-R5.

Local Control Off/Run Forward and Local/Remote Selector Switches (Code S20)

This option provides two factory installed 800F door mounted selector switches. The Local/Remote selector switch determines the source of the start, stop, speed and direction commands. In Local mode, the factory default setting for parameter P038 [Speed Reference] = 4 “Preset Freq.”

In Remote mode, the factory default setting for parameter A051 [Digital In1 Sel] = 6 “Comm Port.” The Off/Run Forward selector switch allows the drive to be started and stopped when in Local Control.

Component Specifications

Bulletin 800F Devices	IEC style, Internationally rated Meet IP65/IP66 and NEMA/UL Type 4/4X/13 UL Listed, CSA Certified 10 amp contacts Screw terminals, 0.3...3.5 mm ² (22...12 AWG) maximum
Local Control Off/Run Forward Selector Switch	2 position, Maintained, 1 N.O. contact
Local/Remote Selector Switch	2 position, Maintained, 1 N.O. contact
Legend Plate	30 x 50 mm, Black with white lettering
Wiring	0.8 mm ² (18 AWG), Blue
Schematic	Figure 12 on page 39

This option is not compatible with Codes R3, R5, S1, S4, S7, S8, S21 or S22.

Local/Off/Remote Selector Switch With One Normally Open Interposing Relay (Code S21)

This 800F door mounted operator device and interposing relay option is factory installed and provides a Local/Off/Remote selector switch.

The Local/Off/Remote selector switch will start the drive in Local mode and stop it in Off mode. In Remote mode, the drive will be stopped and started from the factory installed CR1 contact which is energized by a customer supplied and protected 120V AC source. In all cases, the Stop input to the drive must be present before the drive will start.

In both Local and Remote modes, the speed source is parameter A070 [Preset Freq 0].

Component Specifications

Bulletin 800F Devices	IEC style, Internationally rated Meet IP65/IP66 and NEMA/UL Type 4/4X/13 UL Listed, CSA Certified 10 amp contacts Screw terminals, 0.3...3.5 mm ² (22...12 AWG) maximum
Local/Off/Remote Selector Switch	3 position, Maintained, 2 N.O. contacts
Interposing Control Relay	1 relay, 10 amp, 120V AC coil, Octal base
Legend Plate	30 x 50 mm, Black with white lettering
Wiring	0.8 mm ² (18 AWG), Blue
Schematic	Figure 14 on page 41

This option is not compatible with Codes R3, R5, S1, S4, S7, S8, S20 or S22.

Spring Return Hand-Off-Auto Selector Switch (Code S22)

This 800F door mounted operator device is factory installed and provides a Hand/Off/Auto selector switch. The Hand position is equipped with a spring return.

The Hand/Off/Auto selector switch will start the drive while held in Hand mode and stop the drive in Off mode. The selector switch has a spring return disallowing the operator to remain in Hand. In Auto mode the drive will be stopped and started from remote contact closures. In all cases, the Stop input to the drive must be present before the drive will start.

The Hand/Off/Auto selector switch also determines the source of the actual drive speed reference. In Hand mode, speed source is parameter A072 [Preset Freq 2]. In Auto mode, speed source is parameter A071 [Preset Freq 1].

If the door mounted speed potentiometer (Option S18) is supplied and it is intended to be the speed reference in Hand mode, set parameter A052 [Digital In2 Sel] to option 13 “10V In Ctrl.”

Spring Return HOA Selector Switch (Code S22)

Speed Reference		Parameter Settings		
Hand Mode	Auto Mode	P038 [Speed Reference]	A051 [Digital In1 Sel]	A052 [Digital In2 Sel]
Preset Speed	Preset Speed	4 “Preset Freq”	4 “Preset Freq”	4 “Preset Freq”
	Analog Input (0-10V)	4 “Preset Freq”	13 “10V In Ctrl”	4 “Preset Freq”
	Analog Input (4-20mA)	4 “Preset Freq”	14 “20mA In Ctrl”	4 “Preset Freq”
	Communication Port ⁽¹⁾	4 “Preset Freq”	6 “Comm Port”	4 “Preset Freq”
Speed Pot (Door)	Preset Speed	4 “Preset Freq”	4 “Preset Freq”	13 “10V In Ctrl”
	Analog Input (4-20mA)	4 “Preset Freq”	14 “20mA In Ctrl”	13 “10V In Ctrl”
	Communication Port ⁽¹⁾	4 “Preset Freq”	6 “Comm Port”	13 “10V In Ctrl”
HIM (Door)	Preset Speed	4 “Preset Freq”	4 “Preset Freq”	6 “Comm Port”
	Analog Input (0-10V)	4 “Preset Freq”	13 “10V In Ctrl”	6 “Comm Port”
	Analog Input (4-20mA)	4 “Preset Freq”	14 “20mA In Ctrl”	6 “Comm Port”

(1) Communication port will have both logic and reference control.

Component Specifications

Bulletin 800F Devices	IEC style, Internationally rated Meet IP65/IP66 and NEMA/UL Type 4/4X/13 UL Listed, CSA Certified 10 amp contacts Screw terminals, 0.3...3.5 mm ² (22...12 AWG) maximum
Hand/Off/Auto Selector Switch:	3 position, Hand (spring return), Off, Auto (maintained), 4 N.O. contacts
Legend Plate	30 x 50 mm, Black with white lettering
Wiring	0.8 mm ² (18 AWG), Blue
Schematic	Figure 16 on page 43

This option is not compatible with Codes R3, R5, S1, S4, S7, S20 or S21.

Clear Fault Push Button (Code S23)

This option provides a factory installed 800F Clear Fault push button.

Component Specifications

Bulletin 800F Devices	IEC style, Internationally rated Meet IP65/IP66 and NEMA/UL Type 4/4X/13 UL Listed, CSA Certified 10 amp contacts Screw terminals, 0.3...3.5 mm ² (22...12 AWG) maximum
Clear Fault Push Button:	Flush head, Black, 1 N.O. contact
Legend Plate	30 x 50 mm, Black with white lettering
Wiring	0.8 mm ² (18 AWG), Blue
Schematic	Figure 17 on page 44

This option is not compatible with Code S7.

Quick Disconnects

DeviceNet Quick Disconnect - Bottom (Code E22)

A Brad Harrison, 5 pin, bulkhead, male receptacle is provided and wired to the drive mounted DeviceNet module. The connector is located through the bottom of the enclosure providing a quick disconnect. This option is designed to enhance the DeviceNet offering (Position 12, Code D) and is not compatible with options 4, C, E, P (Position 12), or E23.

To review schematic refer to [Figure 4 on page 31](#).

To review layout refer to [Figure 25 on page 52](#).

For NEMA/UL Type 4 or less stringent environments, the outer connector construction is made of plastic designed to withstand washdown conditions.

DeviceNet Quick Disconnect - Left Side (Code E23)

A Brad Harrison, 5 pin, bulkhead, male receptacle is provided and wired to the drive mounted DeviceNet module. The connector is located through the left side of the enclosure providing a quick disconnect. This option is designed to enhance the DeviceNet offering (Position 12, Code D) and is not compatible with options 4, C, E, P (Position 12), or E22.

To review schematic refer to [Figure 4 on page 31](#).

To review layout refer to [Figure 25 on page 52](#).

For NEMA/UL Type 4 or less stringent environments the outer connector construction is made of plastic designed to withstand washdown conditions.

I/O Options

DeviceNet I/O (4 In/2 Out) w/Spring Return HOA and Power Disconnect Aux. Contact (Position 16+, Code R3)

This option provides a factory installed 800F door mounted operator device, a 100-DNY42R and a power disconnect auxiliary contact mounted internal to the cabinet.

The Hand/Off/Auto selector switch will start the drive while held in the Hand mode and stop it in the Off mode. The default speed reference comes from parameter P038, option 4 (Preset Freq). The selector switch has a spring return disallowing the operator to remain in Hand. When in Auto the default speed reference is derived parameter A051, option 4 (Preset Freq).

The 100-DNY42R is powered by DeviceNet and provides control based on customer control parameters.

This option is prewired with an auto contact from the Hand/Off/Auto selector switch between the I/O V+ and IN0 terminals. The main power disconnect auxiliary contact is wired between the I/O V+ and IN1 terminals indicating if the disconnect is on or off. Two inputs and two outputs are available for customer use.

Component Specifications

Bulletin 800F Devices	IEC style, Internationally rated Meet IP65/IP66 and NEMA/UL Type 4/4X/13 UL Listed, CSA Certified 10 amp contacts Screw terminals, 0.3...3.5 mm ² (22...12 AWG) maximum
Hand/Off/Auto Selector Switch	3 position, Hand (spring return), Off, Auto (maintained) 3 N.O. & 3 N.C. contacts
Legend Plate	30 x 50 mm, Black with white lettering
Wiring	0.8 mm ² (18 AWG), Blue
100-DNY42R	cULus Listed, CSA, CE DeviceLogix™, Rotary address switches 24V DC or 120V AC inputs High-Capacity transistor or Relay outputs ODVA Compliance v2.0 Tested Power Disconnect Auxiliary Contact 1 N.O. & 1 N.C. Side mounted contacts
Schematic	Figure 18 on page 45

This option must be used with the drive mounted DeviceNet option D (Position 12) and is not compatible with options R4, R5, S1, S4, S7, S8, S20, S21 or S22. The drive mounted DeviceNet and the 100-DNY42R will appear as separate nodes on the communication system.

DeviceNet Point I/O w/IB4 (4 Inputs) (Position 16+, Code R4)

This option provides a factory installed 1734-ADNX Point I/O Scanner in combination with a 1734-IB4 (4 input) four point, 24V DC sink input.

The drive DeviceNet is prewired to the subnet connector of the 1734-ADNX. The customer is required to make the DeviceNet connection directly to the 1734-ADNX network connector. The 1734-IB4 is connected via a backplane offering four available inputs for customer use.

The Point I/O Scanner allows data to be gathered from the drive mounted DeviceNet and the 1734-IB4 (4 input) appear as one node on the communication system.

Refer to publication 1734-IN051 for more detail on the 1734-IB4.

Component Specifications

1734-ADNX Devices	IEC style, Internationally rated Meet IP65/IP66 and NEMA/UL Type 4/4X/13 UL Listed, CSA Certified 10 amp contacts Screw terminals, 0.3...3.5 mm ² (22...12 AWG) maximum
1734-IB4 Devices	Refer to publication 1734-IN051
Schematic	Figure 19 on page 46

This option must be used with the drive mounted DeviceNet option D (Position 12) and is not compatible with options 4, C, E, P (Position 12), R3, or R5.

Note: Customer is required to supply external 24V DC/AC to power 1734-ADNX scanner.

DeviceNet I/O (4 In/ 2 Out) w/Spring Return HOA, Power Disconnect Aux. Contact, and 4 I/O Quick Disconnects (Position 16+, Code R5)

This option provides a factory installed 800F door mounted operator device, a 100-DNY42R mounted internal to the cabinet, a power disconnect auxiliary contact, four I/O quick disconnects, and a 24V DC male receptacle.

The Hand/Off/Auto selector switch will start the drive while held in the Hand mode and stop it in the Off mode. The default speed reference comes from parameter P038, option 4 (Preset Freq). The selector switch has a spring return disallowing the operator to remain in Hand. When in Auto the default speed reference is derived parameter A051, option 4 (Preset Freq).

The 100-DNY42R is powered by DeviceNet and provides control based on customer control parameters. The inputs and outputs are powered by customer supplied 24V DC.

This options is prewired with an auto contact from the Hand/Off/Auto selector switch between the I/O V+ and IN0 terminals. The main power disconnect auxiliary contact is wired between the I/O V+ and IN1 terminals indicating if the disconnect is on or off. The four I/O quick disconnects allow the customer to quickly connect to the remaining two inputs and outputs that are available for customer use.

Component Specifications

Bulletin 800F Devices	IEC style, Internationally rated Meet IP65/IP66 and NEMA/UL Type 4/4X/13 UL Listed, CSA Certified 10 amp contacts Screw terminals, 0.3...3.5 mm ² (22...12 AWG) maximum
Hand/Off/Auto Selector Switch	3 position, Hand (spring return), Off, Auto (maintained) 3 N.O. & 3 N.C. contacts
Legend Plate	30 x 50 mm, Black with white lettering
Wiring	0.8 mm ² (18 AWG), Blue
100-DNY42R	cULus Listed, CSA, CE DeviceLogix™, Rotary address switches 24V DC or 120V AC inputs High-Capacity transistor or Relay outputs ODVA Compliance v2.0 Tested Power Disconnect Auxiliary Contact 1 N.O. & 1 N.C. Side mounted contacts
Receptacle Shell	Black anodized machined aluminum
Connector Insert	Nylon
Contacts	Machined brass with gold over nickel plating
Schematic	Figure 20 on page 47

This option must be used with the drive mounted DeviceNet option D (Position 12) and is not compatible with options R3, R4, S1, S4, S7, S8, S20, S21 or S22. The drive mounted DeviceNet and the 100-DNYR42 will appear as separate nodes on the communication system.

Control Wiring Overview

Chapter Objectives

This chapter describes the control and signal wiring connection options.

For information on ...	See page ...
Control Wiring Overview	27
Schematic Drawings	28

Control Wiring Overview

Refer to the PowerFlex 40 User Manual for additional detailed information about control and signal wiring.

The Control I/O Terminal Block (TB1) and Relay Terminal Block (TB2) located on the drive Main Control Board provide terminals for interfacing customer supplied control inputs and outputs. All analog and discrete control wiring will be made at these terminals.

To connect control and signal wiring to the drive package:

- ❑ 1. Wire the control and signal leads by routing them according to the drive option type. Note that you must punch openings in the option cabinet of the desired conduit size, following NEC and all applicable local codes and standards. I/O terminal block specifications are listed in [Table 4](#).

Control and signal wires should be separated from power wires by at least 0.3 meters (1 foot).

- ❑ 2. Connect the control and signal wiring to the I/O terminals located on the drive.
- ❑ 3. Tighten the I/O terminals to the proper torque according to drive type as shown in [Table 4](#).

Table 4 - I/O Terminal Block Specifications

Voltage Rating	Maximum Wire Size ⁽¹⁾	Minimum Wire Size	Torque
208...460V AC	1.3 mm ² (16 AWG)	0.13 mm ² (26 AWG)	0.5...0.8 N•m (4.4...7 lb•in)

(1) Maximum/minimum sizes that the terminal block will accept - these are not recommendations.

Schematic Drawings

Figure 1 - Power Distribution Option

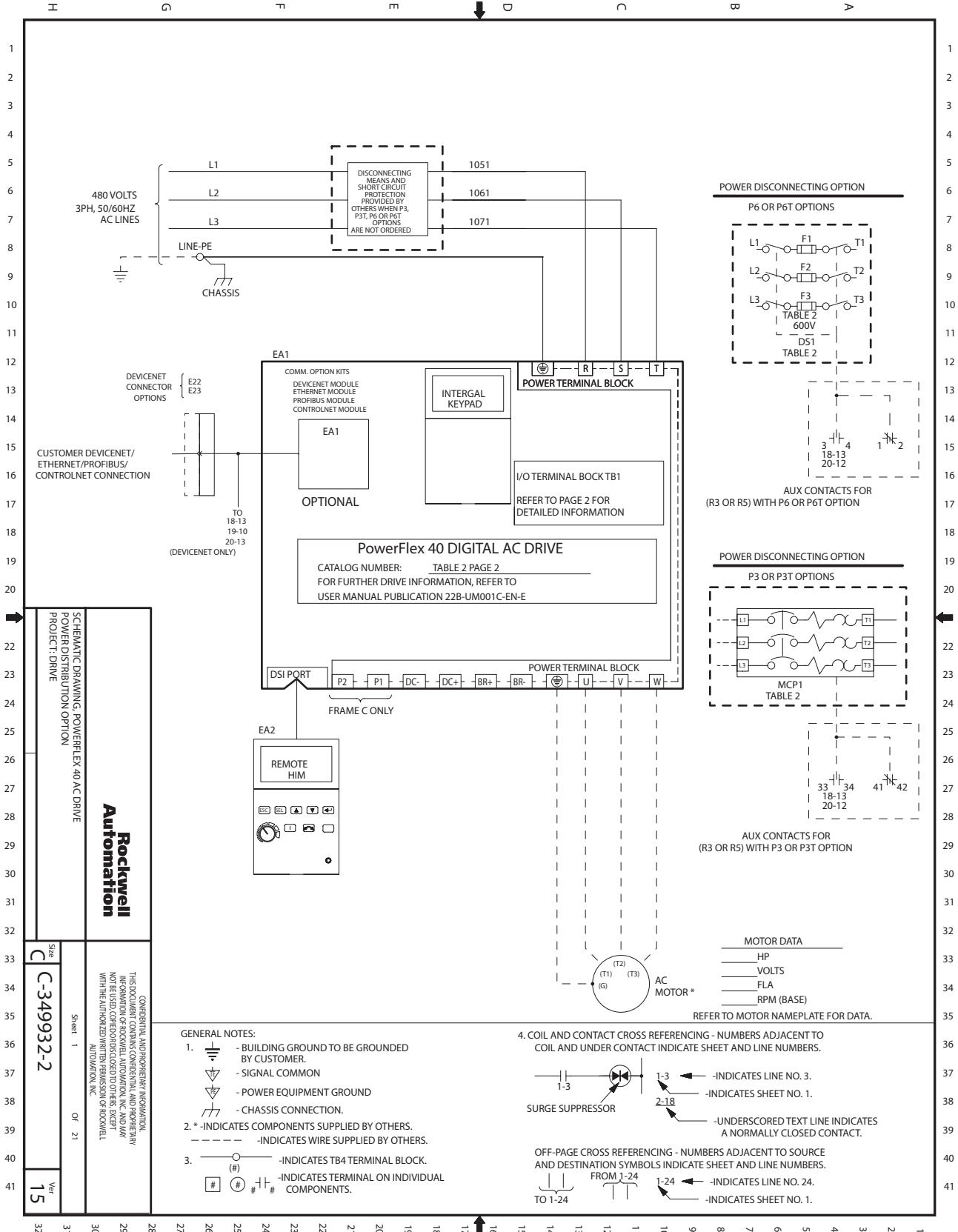

Figure 2 - Drive Ratings

TABLE 2											
THREE PHASE											
DRIVE RATINGS					FUSE RATINGS (P6 OPTION)			P6/P6T OPTIONS	P3/P3T OPTIONS	P3 OPTION	
CATALOG NO.	FRAME	HP	VOLTAGE	FLA	TYPE	AMP	VOLT	CATALOG NO.	CATALOG NO.	KIT NO.	
22B-D1P4F104	B	.5	342-528	1.4	LP//AJT	3	600V	194R-J30-1753	140M-C2E-B40	363326	
22B-D2P3F104	B	1	342-528	2.3	LP//AJT	6	600V	194R-J30-1753	140M-C2E-B63	363333	
22B-D4P0F104	B	2	342-528	4.0	LP//AJT	10	600V	194R-J30-1753	140M-D8E-C10	363337	
22B-D6P0F104	B	3	342-528	6.0	LP//AJT	15	600V	194R-J30-1753	140M-D8E-C16	363341	
22B-D010F104	B	5	342-528	10.5	LP//AJT	20	600V	194R-J30-1753	140M-D8E-C25	363345	
22B-D012F104	C	7.5	342-528	12.0	LP//AJT	25	600V	194R-J30-1753	140M-F8E-C25	363349	
22B-D017F104	C	10	342-528	17.0	LP//AJT	30	600V	194R-J30-1753	140M-F8E-C32	363353	
22B-D024F104	C	15	342-528	24.0	LPJ	50	600V	194R-J60-1753	140M-F8E-C45	363357	

SCHEMATIC DRAWING, POWERFLEX 40 AC DRIVE
 DRIVE RATINGS
 PROJECT: DRIVE

Rockwell Automation

Size **C** Ver **15**

C-349932-2

Sheet 2 of 21

CONSENTIAL AND PROPRIETARY INFORMATION. THIS DOCUMENT CONTAINS CONFIDENTIAL AND PROPRIETARY INFORMATION OF ROCKWELL AUTOMATION, INC. AND MAY NOT BE USED, COPIED OR DISCLOSED TO OTHERS, EXCEPT WITH THE AUTHORIZED WRITTEN PERMISSION OF ROCKWELL AUTOMATION, INC.

Figure 3 - Control Logic Options 4, C, D, E & P

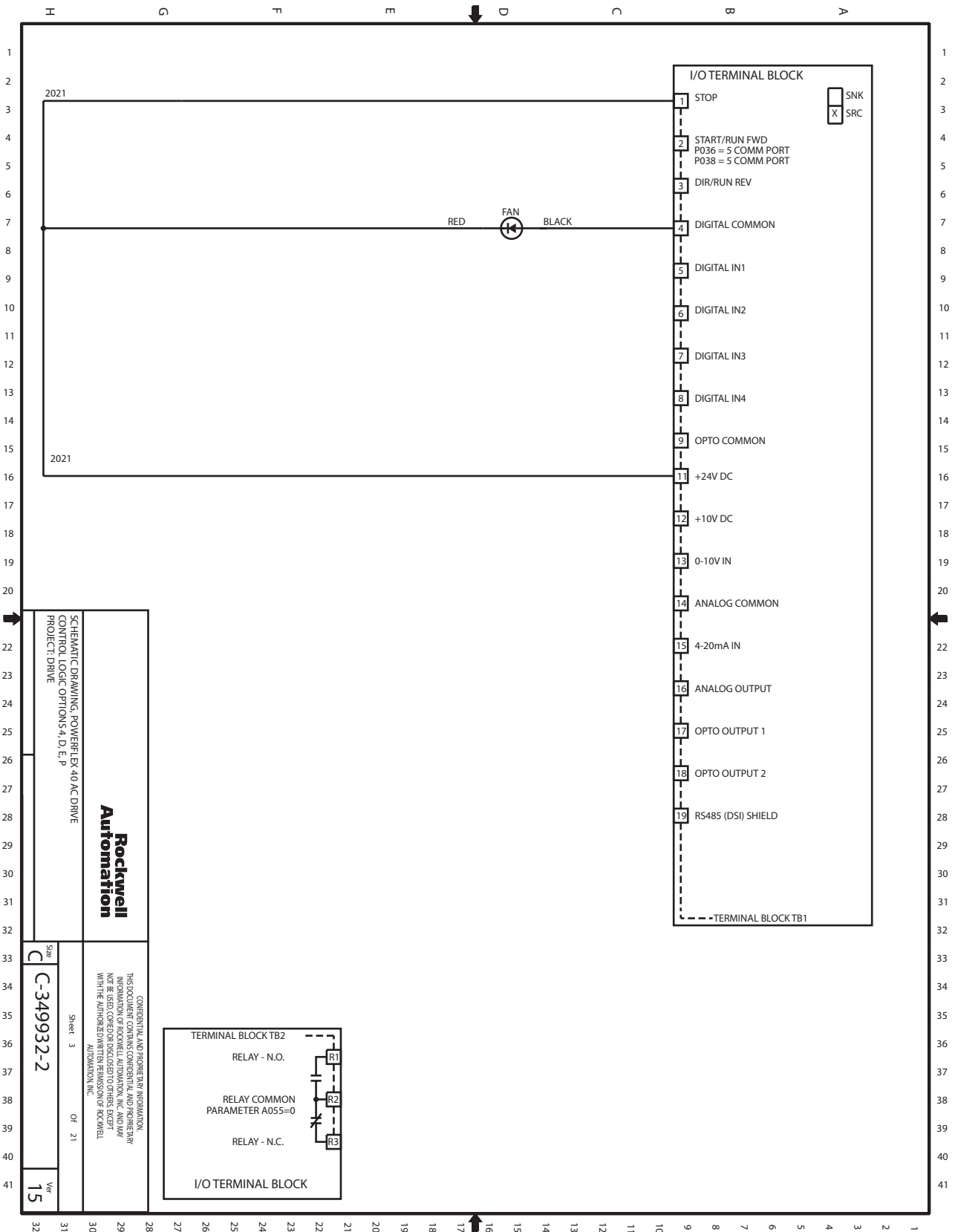

Figure 4 - Control Logic Option S1

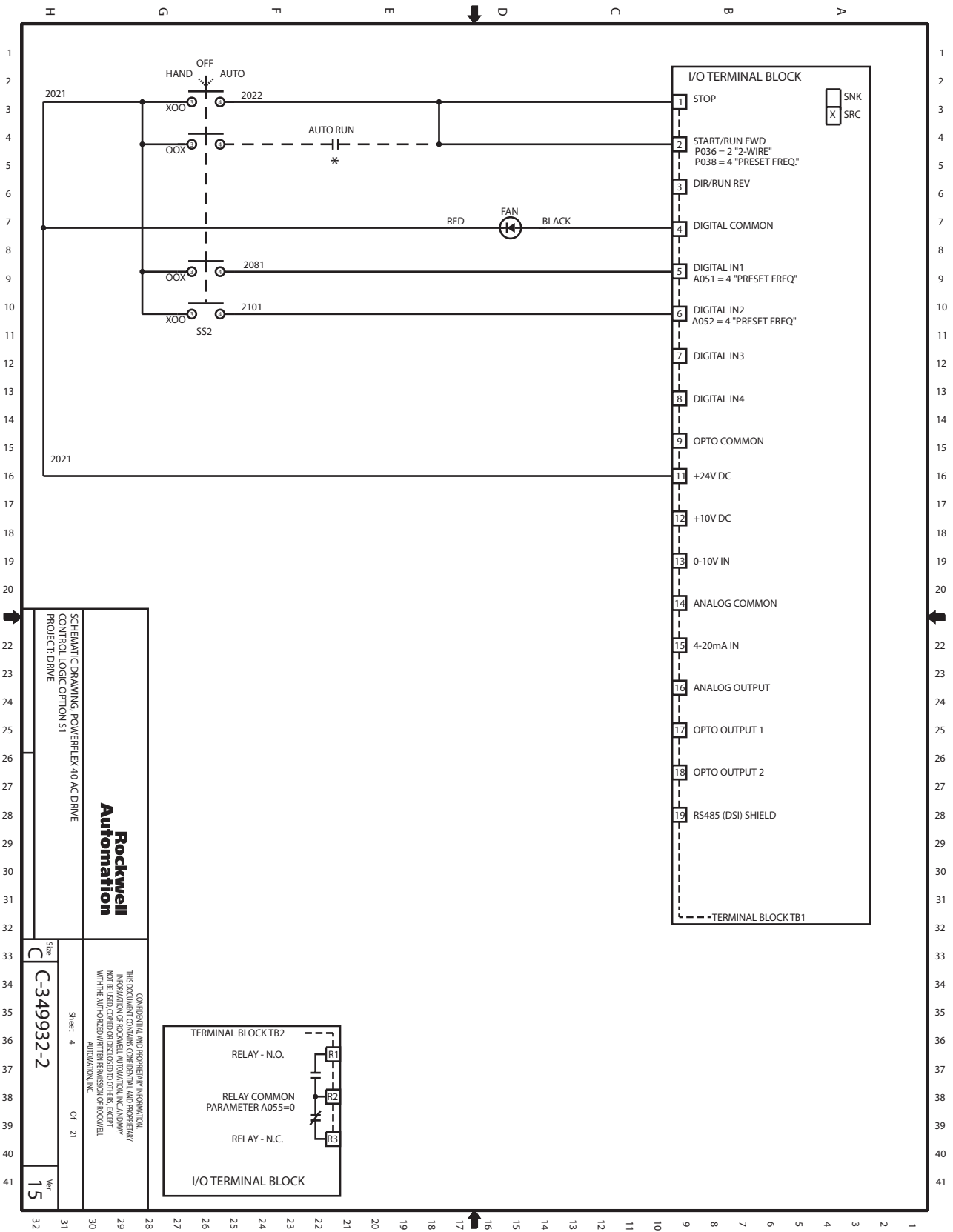

Figure 5 - Control Logic Option S1 & S8

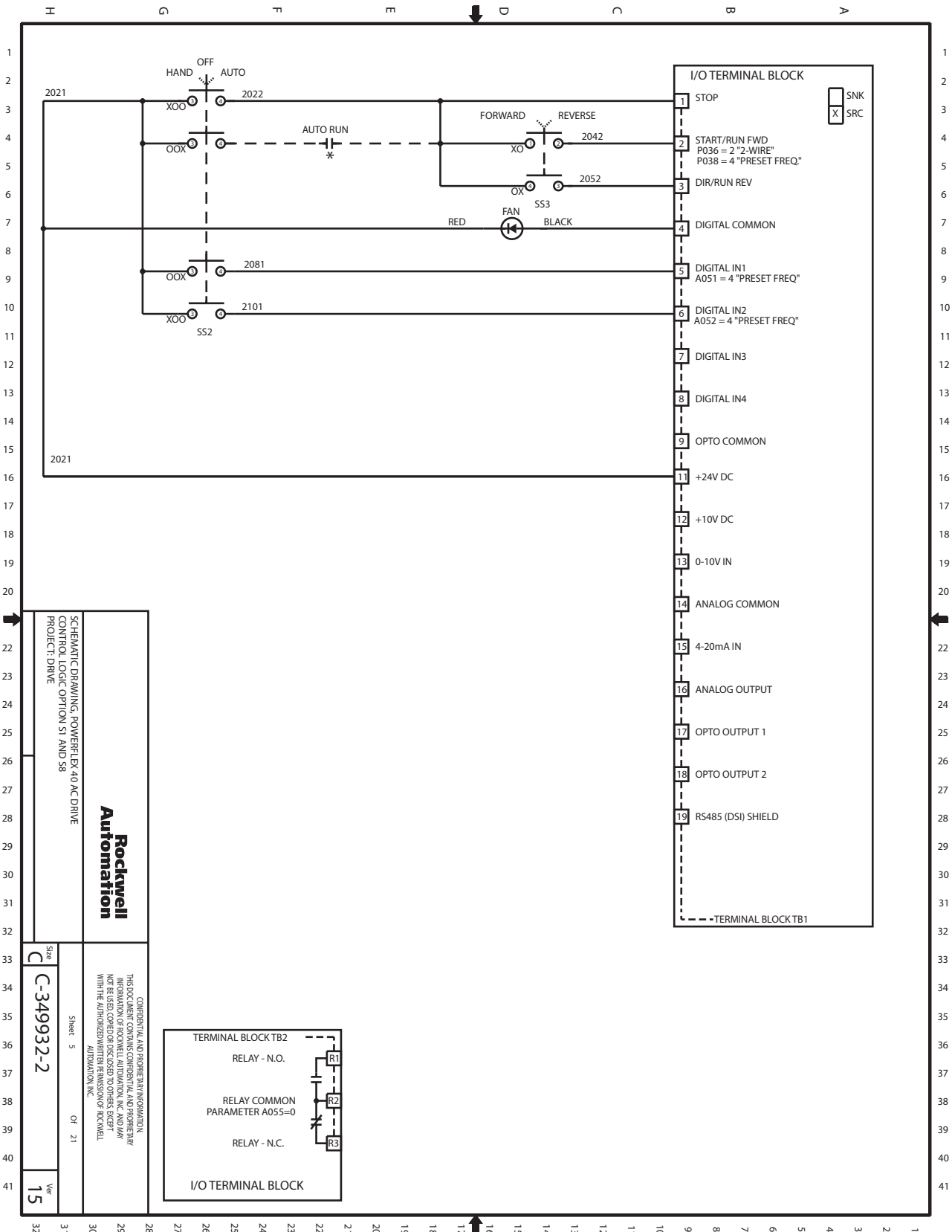

Figure 6 - Control Logic Option S4

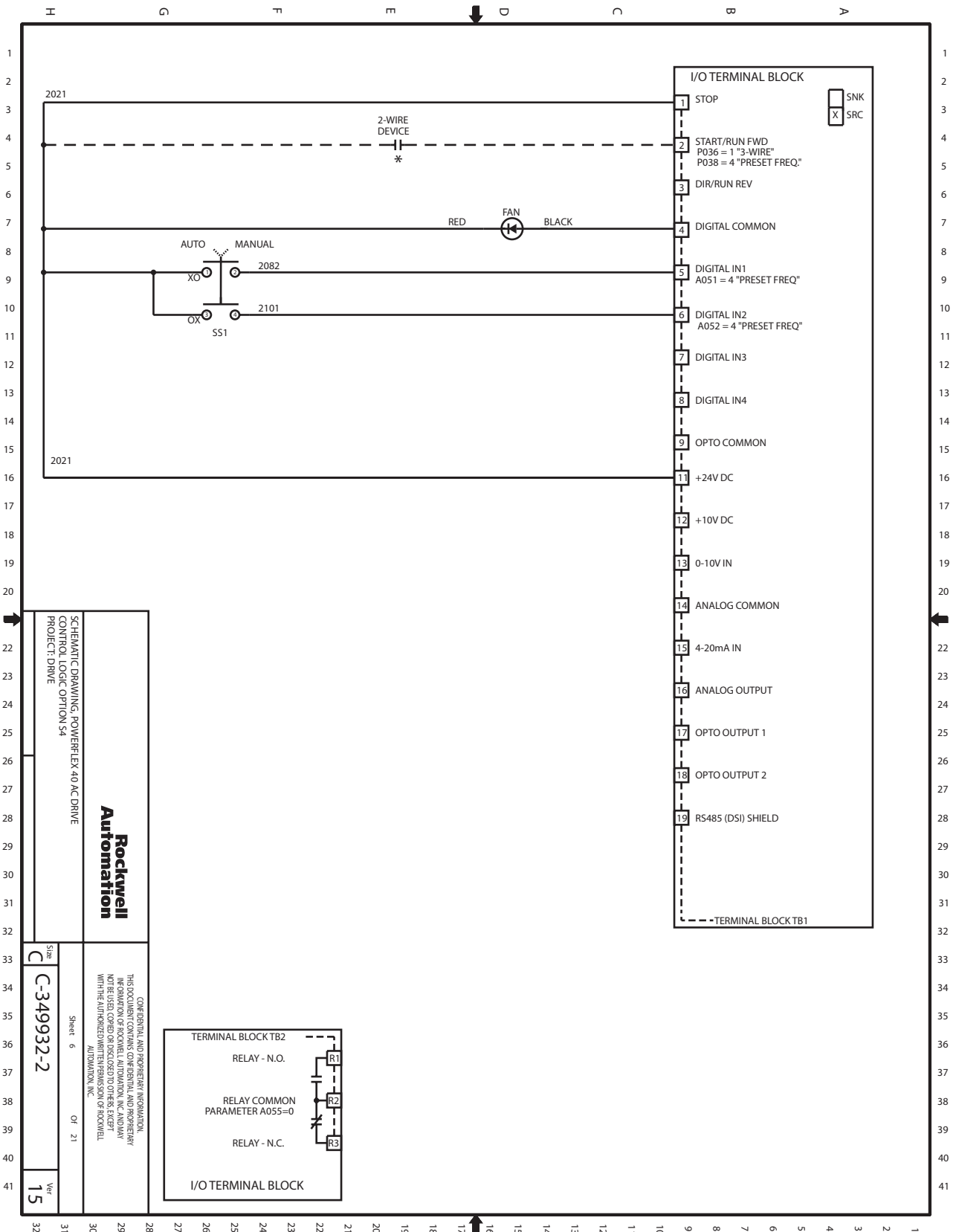
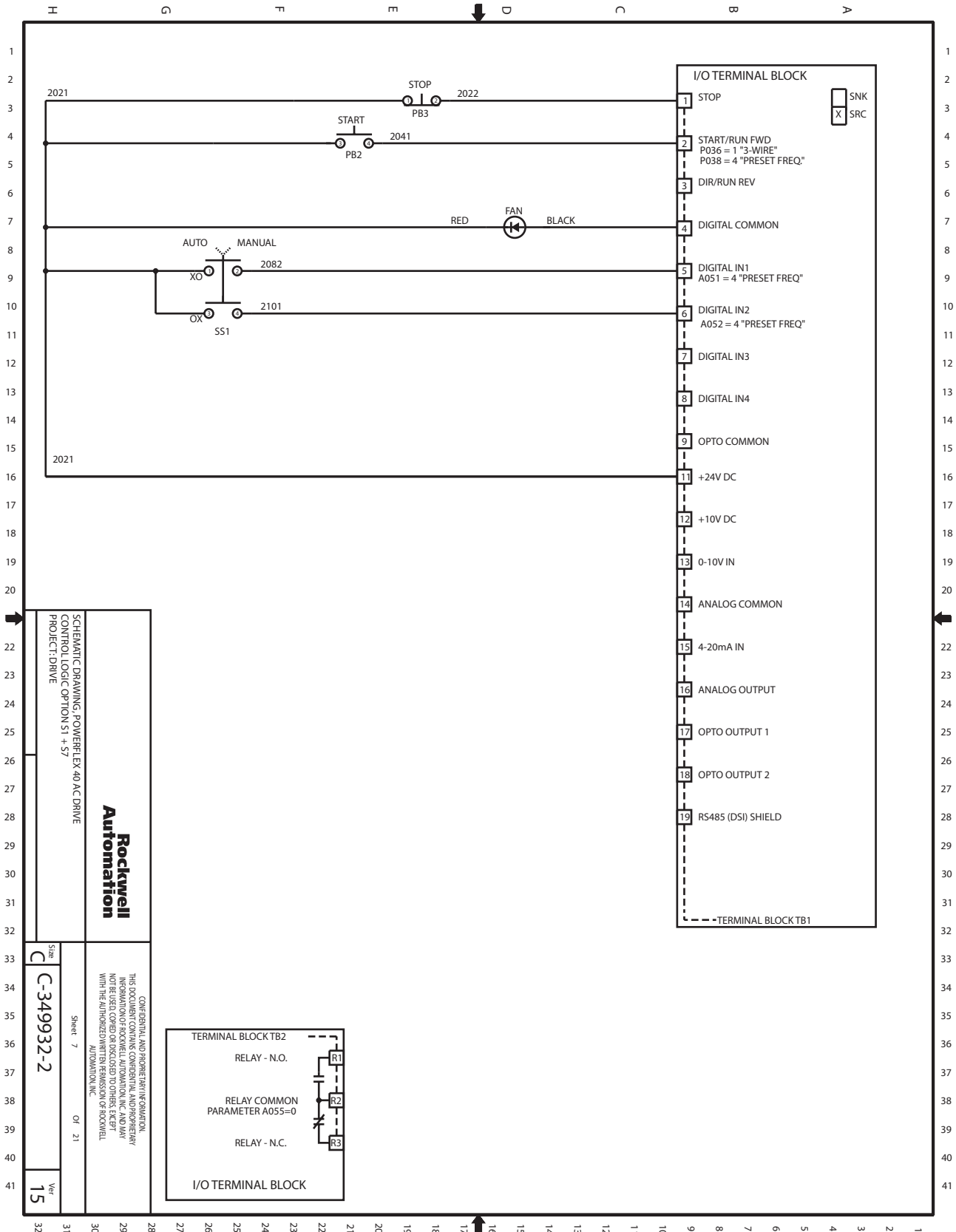

Figure 7 - Control Logic Option S4 & S7



SCHEMATIC DRAWING POWERLEX 400 AC DRIVE
CONTROL LOGIC OPTION S1 + S7
PROJECT: DRIVE

**Rockwell
Automation**

Size C
C-349932-2
Sheet 7
Of 21
Ver 15

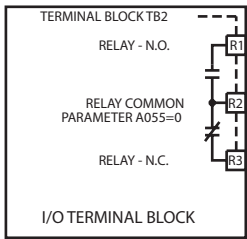

Figure 8 - Control Logic Option S4 with S8

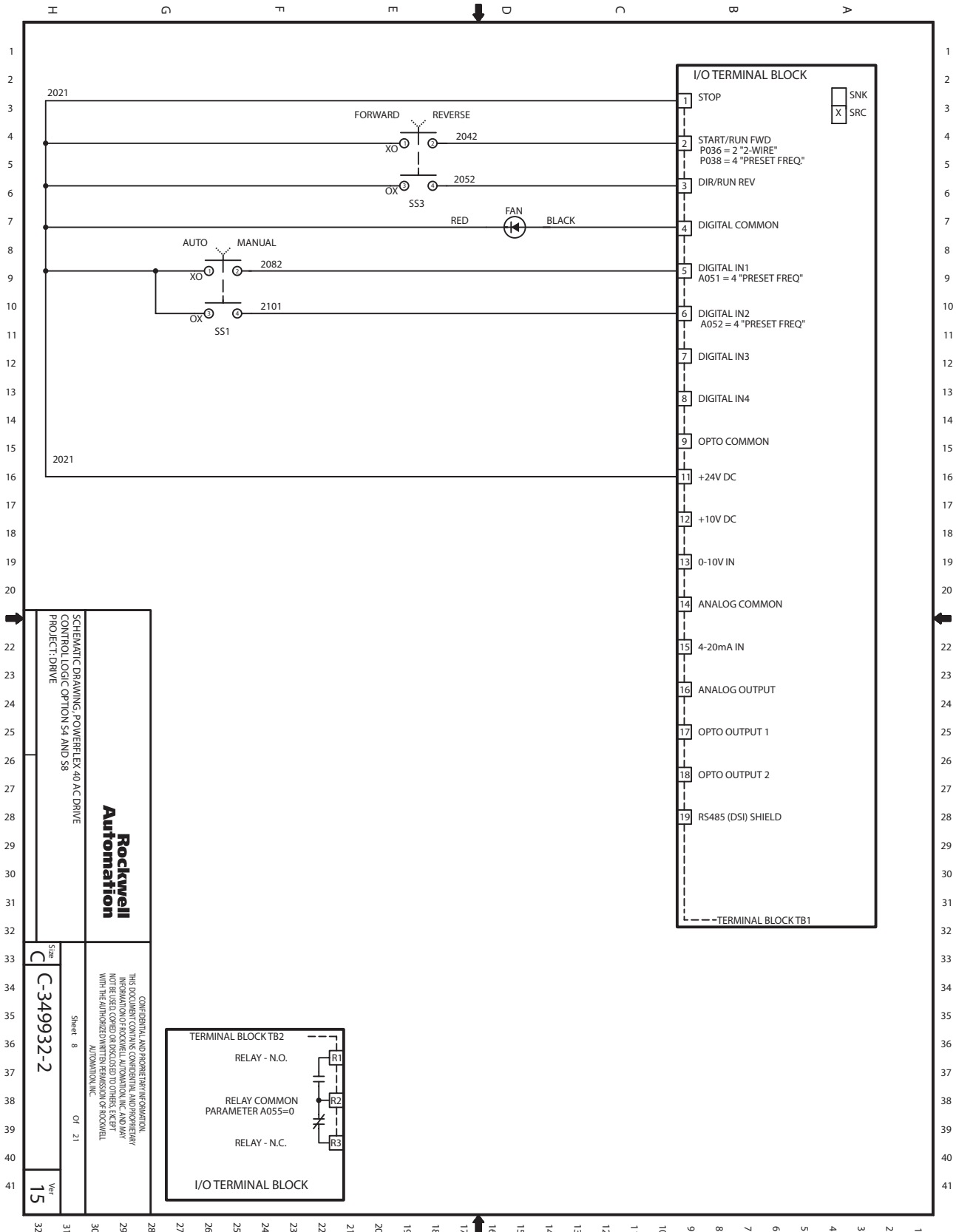

Figure 9 - Control Logic Option S7

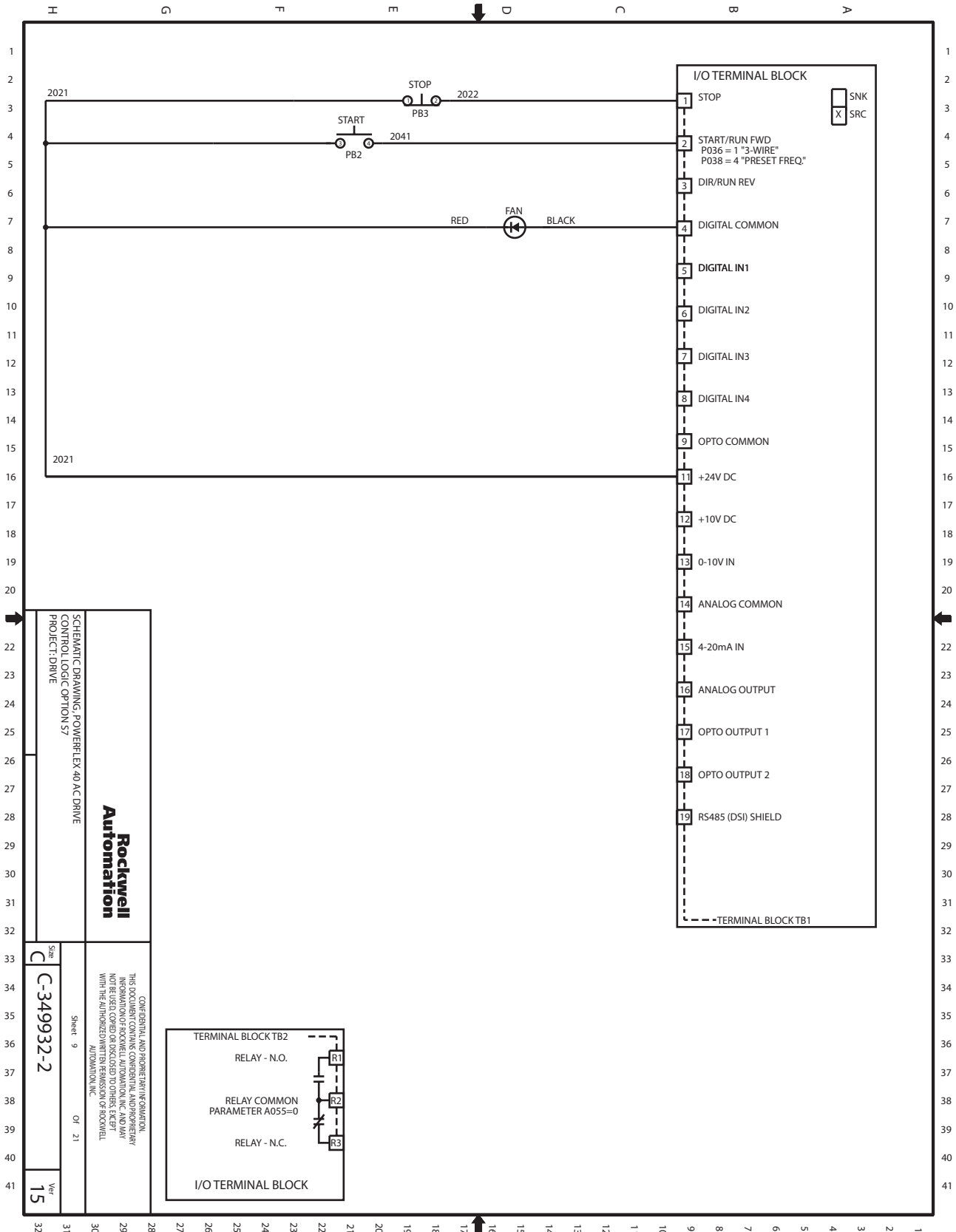

Figure 10 - Control Logic Option S7 and S8

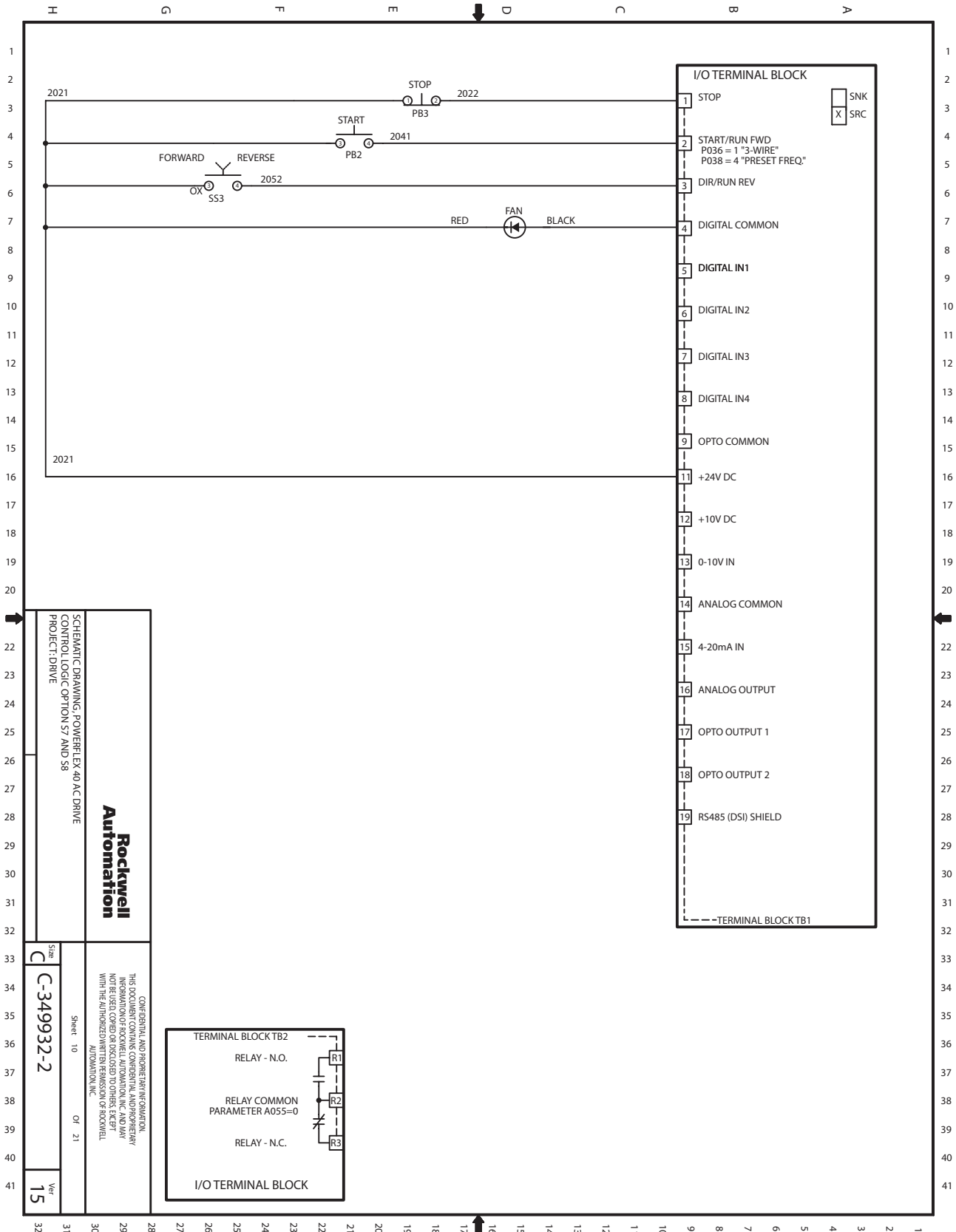

Figure 11 - Control Logic Option S8

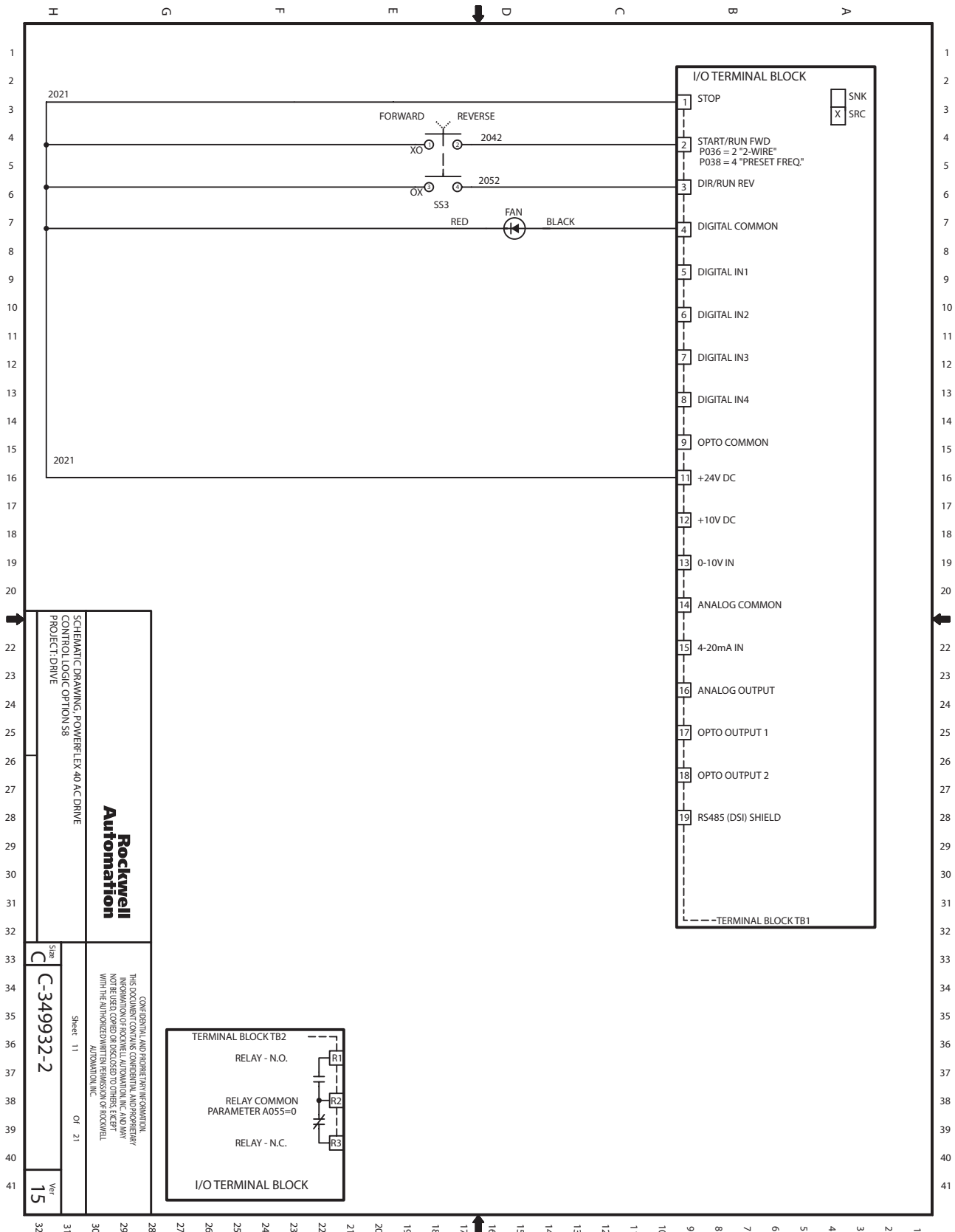

Figure 12 - Control Logic Option S20

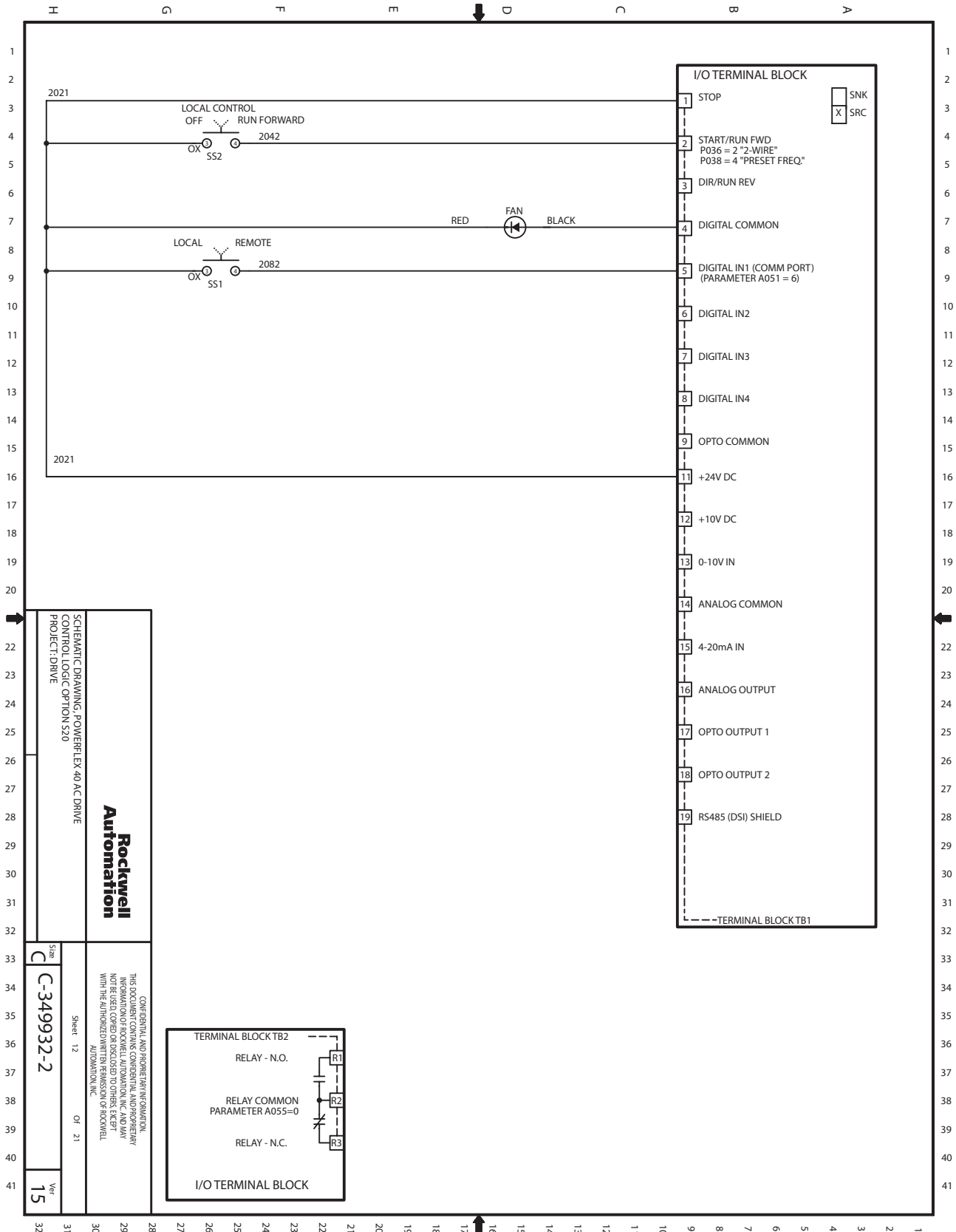

Figure 13 - Control Logic Option S18

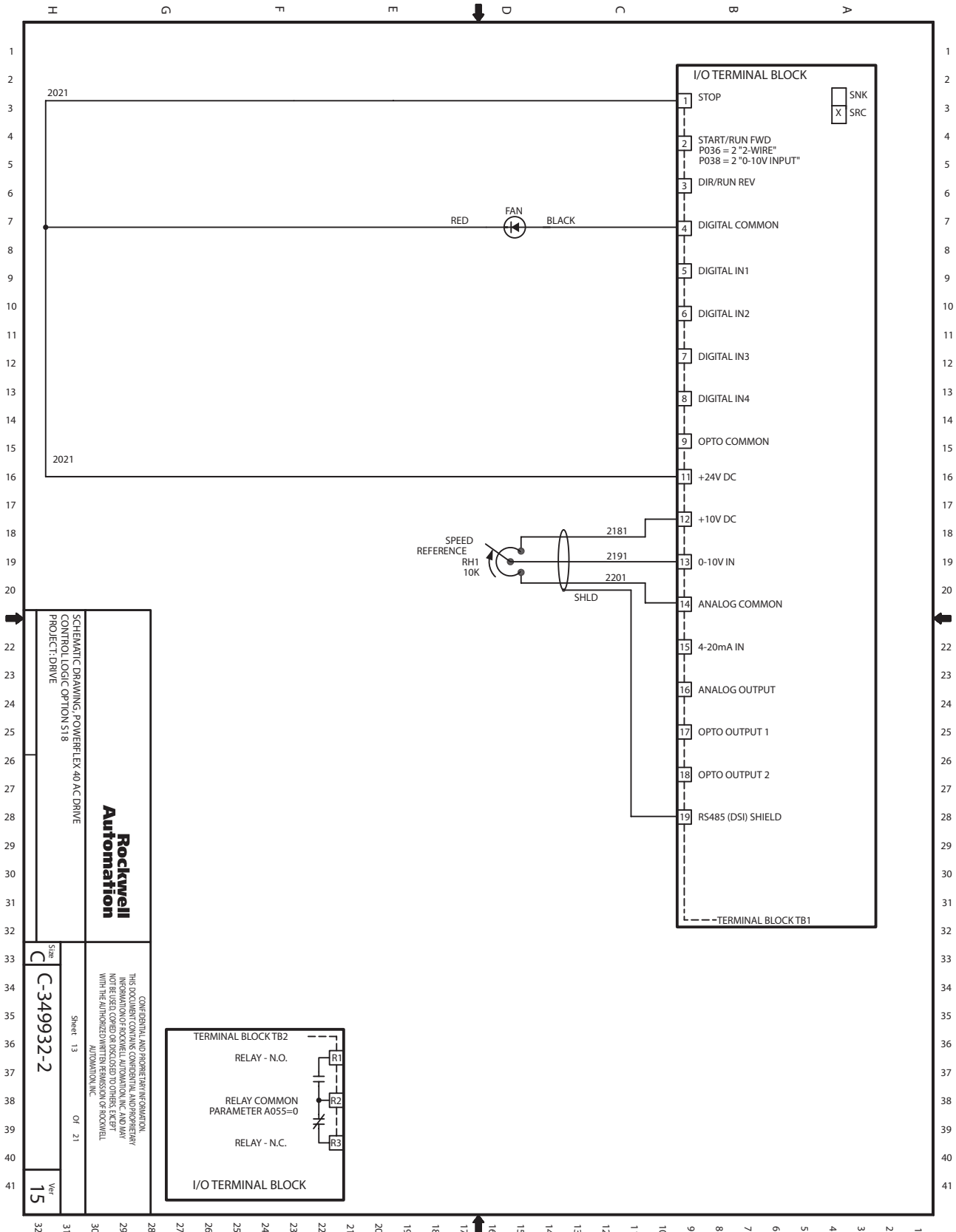

Figure 14 - Control Logic Option S21

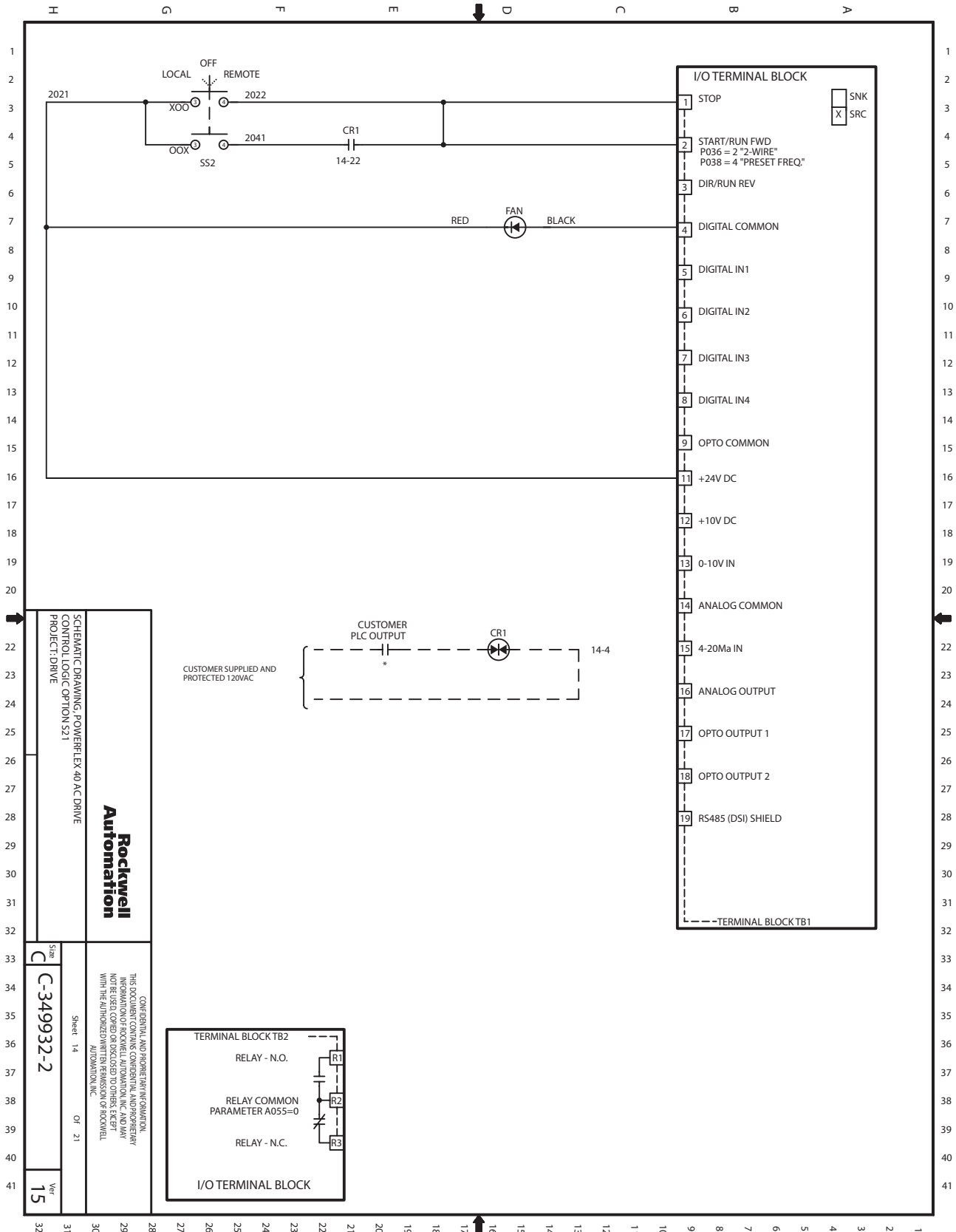
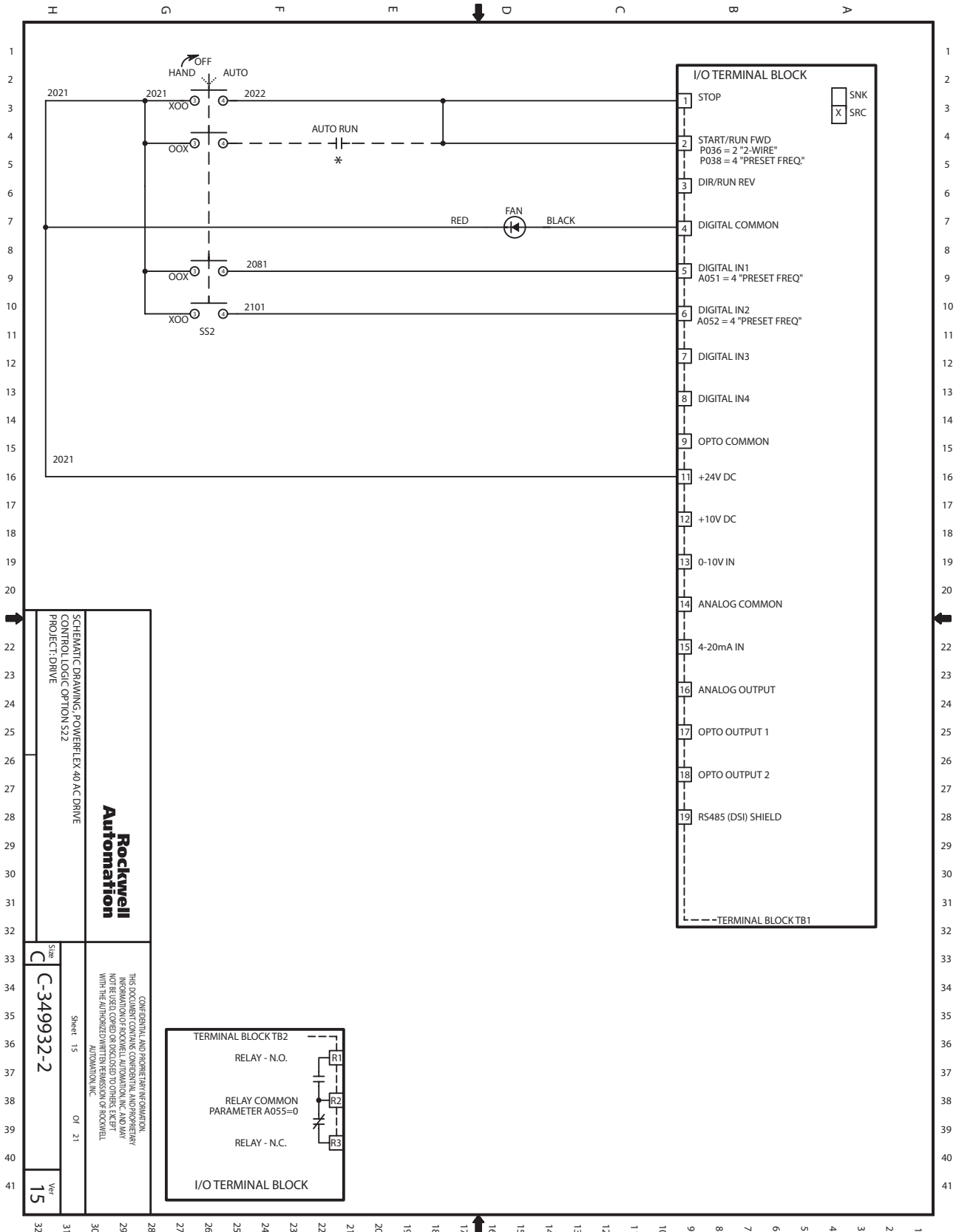

Figure 15 - Control Logic Option S22



SCHEMATIC DRAWING POWERLEX 400 AC DRIVE
CONTROL LOGIC OPTION S22
PROJECT: DRIVE

**Rockwell
Automation**

Size C-349932-2
Sheet 15 of 21
Ver 15

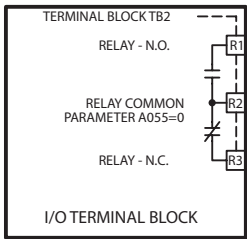
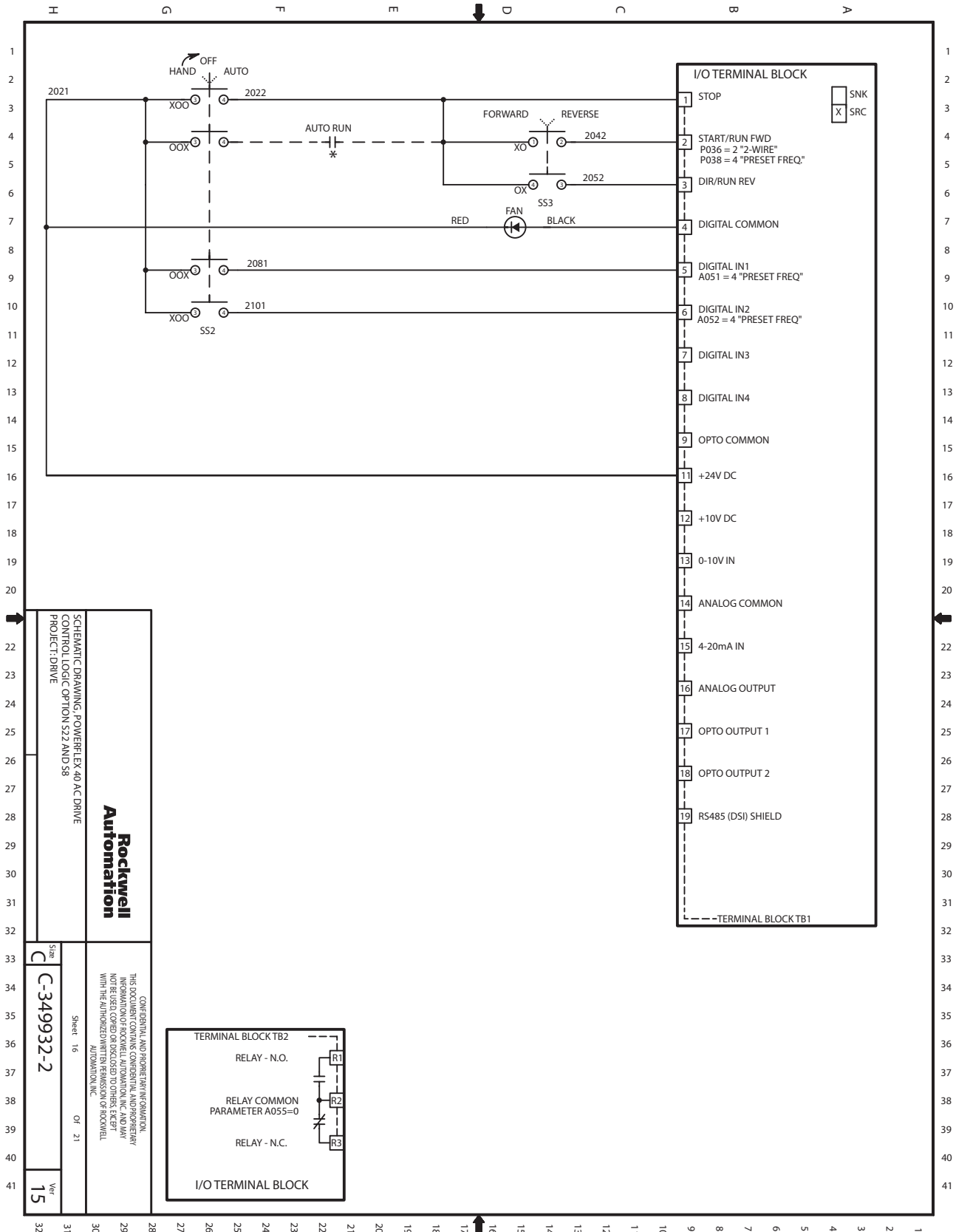

Figure 16 - Control Logic Option S22 & S8



SCHEMATIC DRAWING POWERLEX 40 AC DRIVE
CONTROL LOGIC OPTION S22 AND S8
PROJECT: DRIVE

Rockwell Automation

Size: C
C-349932-2
Sheet 16 of 21
Ver 15

CONFIDENTIAL AND PROPRIETARY INFORMATION
INFORMATION OF ROCKWELL AUTOMATION, INC. AND/OR ANY
OF ITS SUBSIDIARIES. THIS DOCUMENT IS TO BE USED ONLY
WITH THE AUTHORIZED HARDWARE AND SOFTWARE OF ROCKWELL
AUTOMATION, INC.

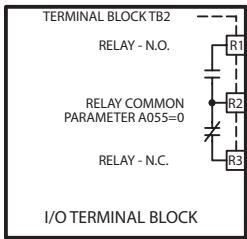

Figure 17 - Control Logic Option S23

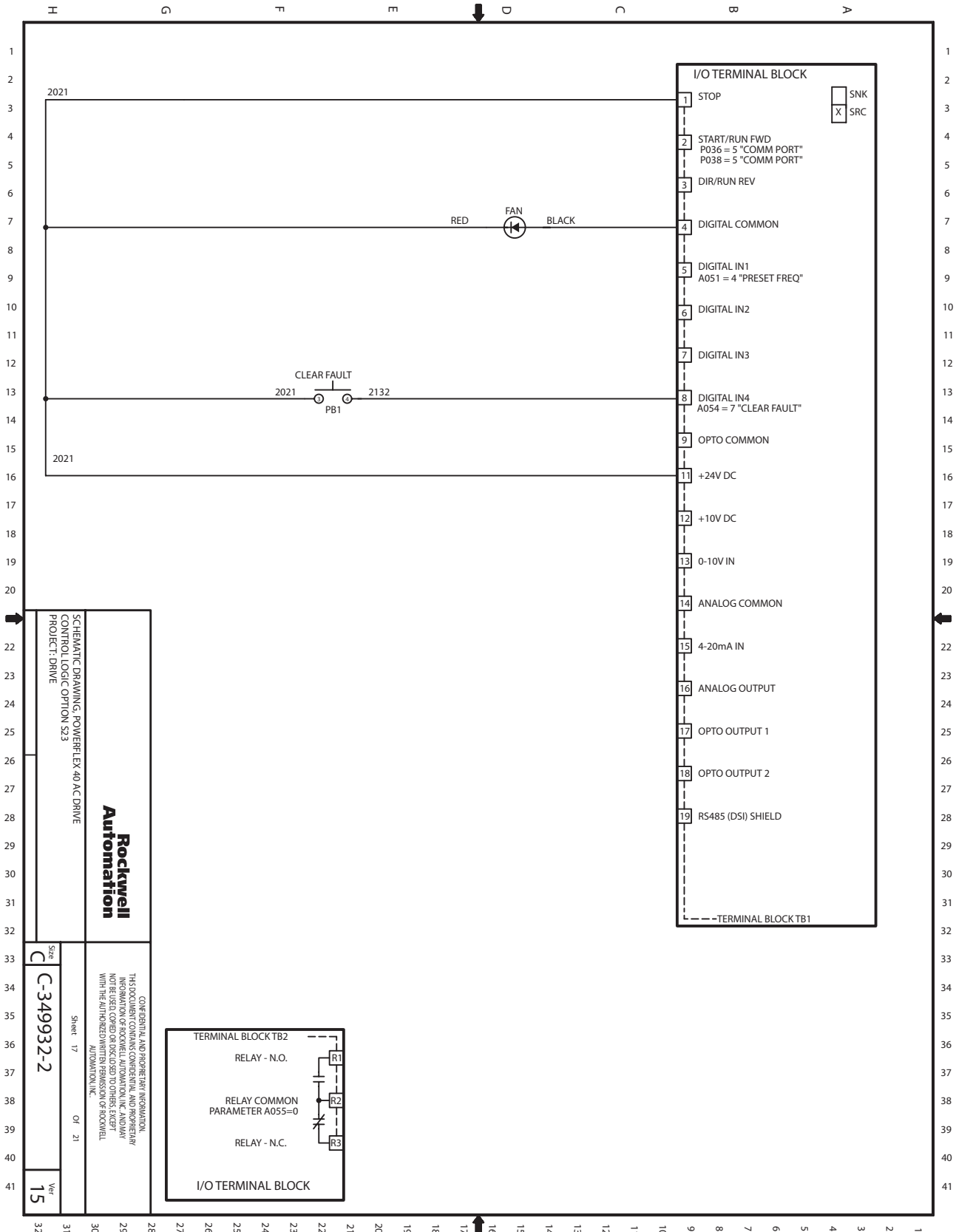

Figure 19 - Control Logic Option R4

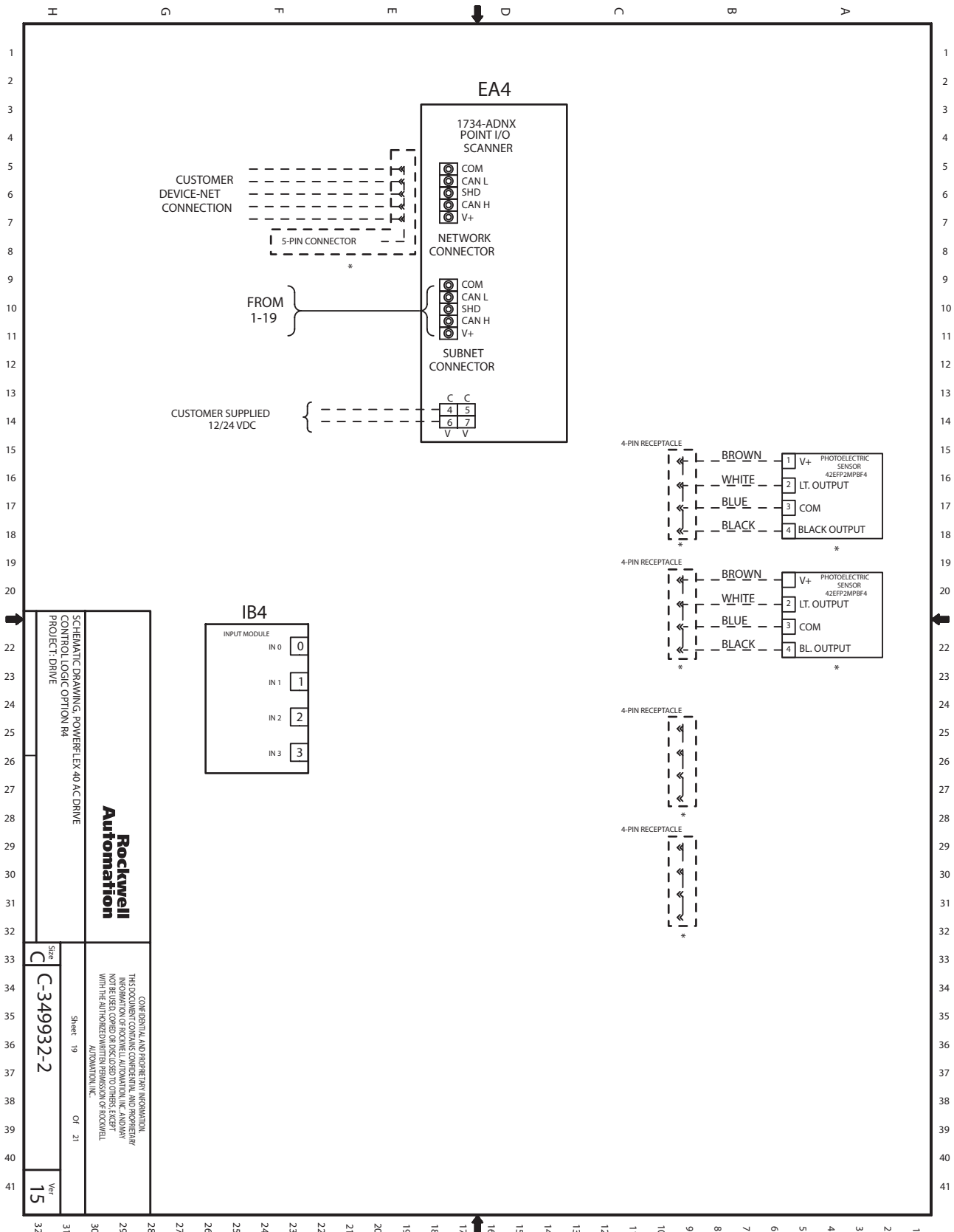

Figure 20 - Control Logic Option R5 with P3/P3T or P6/P6T

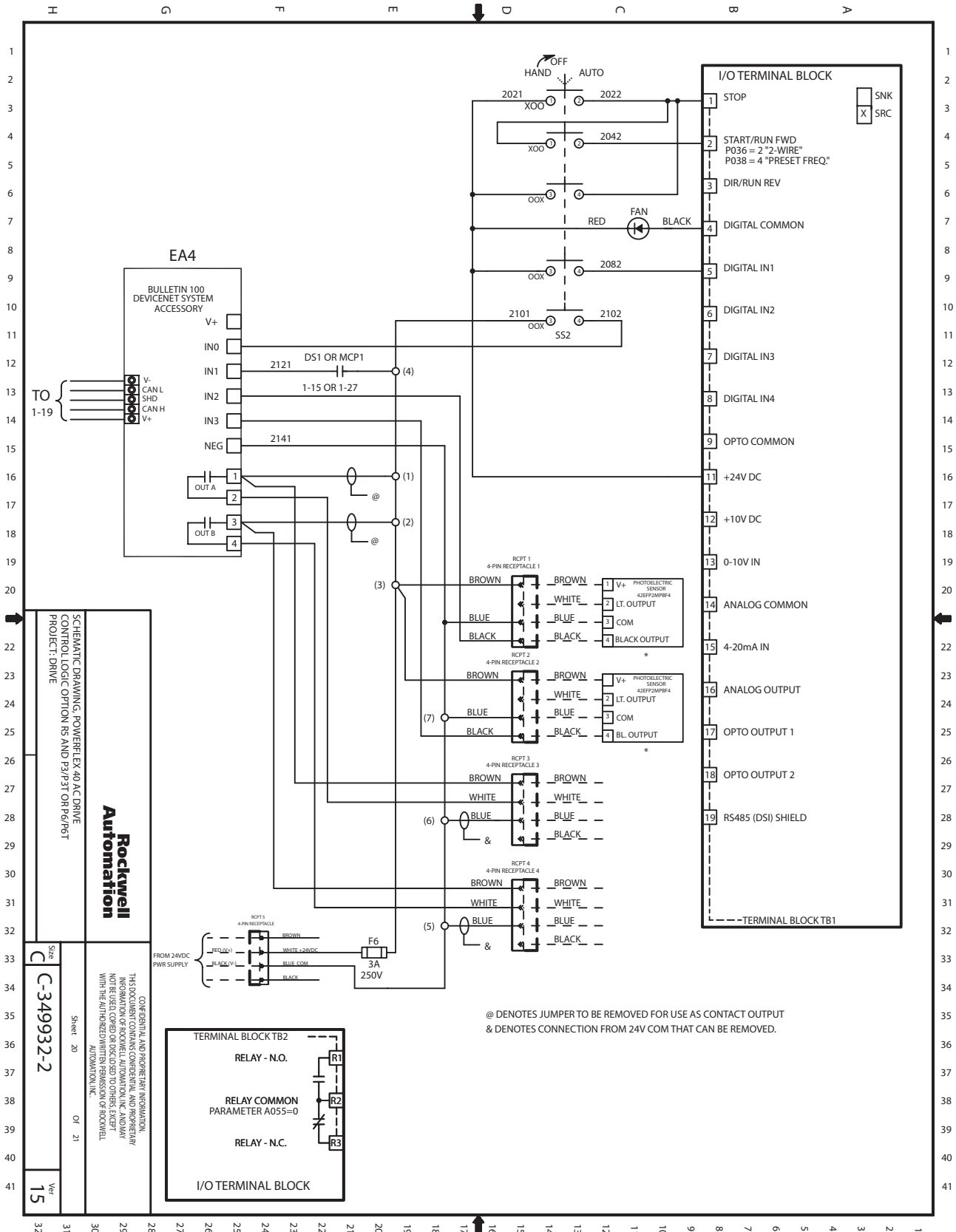

Figure 21 - Interconnect Wire & Parts List

REPLACEMENT COMPONENTS LIST							
SYM.	DESCRIPTION	A-B PART NO.	MANUFACTURER/PART NO.				
EA1	DRIVE UNIT	N/A	REFER TO C-349932-12 FOR CAT NO.				
F1-3	FUSES	N/A	REFER TO TABLE 2 PAGE 2-3 FOR FUSE SIZE AND MANUFACTURER				
DS1	DISCONNECT	N/A	A-B/(194R-J30-1753 OR 194R-J60-1753) REFER TO TABLE 2 PAGE 2-3 FOR SIZE				
MCP1	MTR CIRCUIT PROT.	N/A	A-B (REFER TO TABLE 2 PAGE 2-3 FOR P3 KIT NUMBER OR P3T PART NUMBERS)				
EA1	HIM	N/A	A-B/22-HIM-C25				
EA1	DEVICENET MOD	N/A	A-B/22-COMM-D				
EA1	ETHERNET MOD	N/A <tr <td>EA1</td> <td>PROFIBUS MOD</td> <td>N/A</td> <td>A-B/22-COMM-E</td> <td></td>	EA1	PROFIBUS MOD	N/A	A-B/22-COMM-E	
EA1	CONTRORNET MOD	N/A	A-B/22-COMM-P				
EA1	CONTRORNET MOD	N/A	A-B/22-COMM-C				
SS1	AUTO/MAN SS	N/A	A-B/800FP-SM22PX11				
SS2	H/O/A SEL SW	N/A	A-B/800FP-SM32MX40				
SS3	FOR/REV SS	N/A	A-B/800FP-SM22PX11				
PB1	CLEAR FAULT	N/A	A-B/800FP-F2PX10				
PB2	START PB	N/A	A-B/800FP-F3PX10				
PB3	STOP PB	N/A	A-B/800FP-F4PX01				
CR1	RELAY	N/A	A-B/700-HA32A1				
FAN	FAN	N/A	NMB TECH/2410ML-05W-B30				
RH1	SPEED POT/OPERATOR	N/A	A-B/800FP-POT6	S18 OPTION ONLY			
SS1	LOC/REM SS	N/A	A-B/800FP-SM22PX10	S20 OPTION ONLY			
SS2	OFF/RUN FWD SS	N/A	A-B/800FP-SM22PX10				
SS2	LCL-OFF-REM SS	N/A	A-B/800FP-SM32PX20	S21 OPTION ONLY			
CR1	RELAY	N/A	A-B/700-HA32A1				
SS2	H/O/A SEL SW	N/A	A-B/800FP-SL32PX40	S22 OPTION ONLY			
SS2	H/O/A SEL SW	N/A	A-B/800FP-SL32CRPX50	R3 OPTION			
EA4	DEVNET I/O REL	N/A	A-B/100-DNY42R				
IB4	PLC I/O MOD	N/A	A-B/1734-IB4	R4 OPTION ONLY			
EA4	DEVICENET ADAPTER	N/A	A-B/1734-ADNX				
SS2	H/O/A SEL SW	N/A	A-B/800FP-SL32CRPX50	R5 OPTION			
EA4	DEVNET I/O REL	N/A	A-B/100-DNY42R				
RCPT1-4	RECEPTACLE,MICRO, FEMALE	N/A	A-B/888D-F4AC2-1				
RCPT5	RECEPTACLE 24VDC	N/A	A-B/888D-MA4AE1-A				
F6	FUSE	N/A	BUSSMANN/MDA-3				

EXTERNAL INTERCONNECT WIRING REQUIREMENTS				
POWER				
SEE DRIVE USER MANUAL FOR CABLE RECOMMENDATIONS AND RESTRICTIONS.				
INTERCONNECTION INFORMATION				
WIRE NO.	DEVICE	EXPLANATION	TERMINAL TORQUE	TERMINAL WIRE RANGE
L1	EA1-R	DRIVE INPUT	16-19 LB-IN	16-10 GA
L2	EA1-S			
L3	EA1-T			
PE	LINE-PE	LINE-GROUND	20 LB-IN	14-6 GA
L1	EA1-R	DRIVE INPUT	26-33 LB-IN	16-8 GA
L2	EA1-S			
L3	EA1-T			
PE	LINE-PE	LINE-GROUND	20 LB-IN	14-6 GA
L1	DS1-L1	INCOMING POWER LINES	14 LB-IN	14-8 GA
L2	DS1-L2			
L3	DS1-L3			
PE	LINE-PE	LINE-GROUND	20 LB-IN	14-6 GA
L1	DS1-L1	INCOMING POWER LINES	25 LB-IN	14-4 GA
L2	DS1-L2			
L3	DS1-L3			
PE	LINE-PE	LINE-GROUND	20 LB-IN	14-6 GA
L1	MCP1-L1	INCOMING POWER LINES	22 LB-IN	16-12 GA
L2	MCP1-L2			
L3	MCP1-L3			
PE	LINE-PE	LINE-GROUND	20 LB-IN	14-6 GA
L1	MCP1-L1	INCOMING POWER LINES	31 LB-IN	14-6 GA
L2	MCP1-L2			
L3	MCP1-L3			
PE	LINE-PE	LINE-GROUND	20 LB-IN	14-6 GA
T1	EA1-U	DRIVE OUTPUT	16-19 LB-IN	16-10 GA
T2	EA1-V			
T3	EA1-W			
PE	EA1-PE	MTR-GROUND	16-19 LB-IN	16-10 GA
T1	EA1-U	DRIVE OUTPUT	26-33 LB-IN	16-8 GA
T2	EA1-V			
T3	EA1-W			
PE	EA1-PE	MTR-GROUND	26-33 LB-IN	16-8 GA

SCHEMATIC DRAWING, POWER/ELEX 400 AC DRIVE CONTROL LOGIC OPTION S1 PROJECT: DRIVE		CONFIDENTIAL AND PROPRIETARY INFORMATION THIS DOCUMENT CONTAINS CONFIDENTIAL AND PROPRIETARY INFORMATION OF ROCKWELL AUTOMATION, INC. AND MAY BE SUBJECT TO PATENT AND TRADE SECRET RIGHTS. REPRODUCTION OR TRANSMISSION OF THIS DOCUMENT WITHOUT THE AUTHORIZED WRITTEN PERMISSION OF ROCKWELL AUTOMATION, INC.	Size	Sheet 21	Of 21	Ver
			C	C-349932-2	15	

Mechanical Installation

Chapter Objectives

This chapter provides information on mounting a PowerFlex 40 Standard Configured Drive.

For information on ...	See page ...
Mounting Considerations	49
Dimensions	50
Layout Drawings	52



ATTENTION: The following information is merely a guide for proper installation. The Allen-Bradley Company cannot assume responsibility for the compliance or the noncompliance to any code, national, local or otherwise for the proper installation of this drive or associated equipment. A hazard of personal injury and/or equipment damage exists if codes are ignored during installation.

Mounting Considerations

Environment

Before deciding on an installation site, verify that the PowerFlex Drive Packages are not installed in an area where the ambient atmosphere contains volatile or corrosive gas, vapors or dust. The drives are to be installed per the environmental rating they have been designed for.

Maximum Surrounding Air Temperature

PowerFlex 40 Standard Configured Drives are designed to operate at -10° to 40°C (14° to 104°F) surrounding air temperature. The design of the PowerFlex Standard Configured Drive supports indoor and outdoor applications that are not in direct sunlight.

Minimum Mounting Clearances

Be sure there is adequate clearance for air circulation around the drive. For best air movement, do not mount drives directly above each other. Note that no devices are to be mounted behind the drive. This area must be kept clear of all control and power wiring.

Figure 22 - Minimum Mounting Clearances
 Dimensions are in millimeters and (inches).

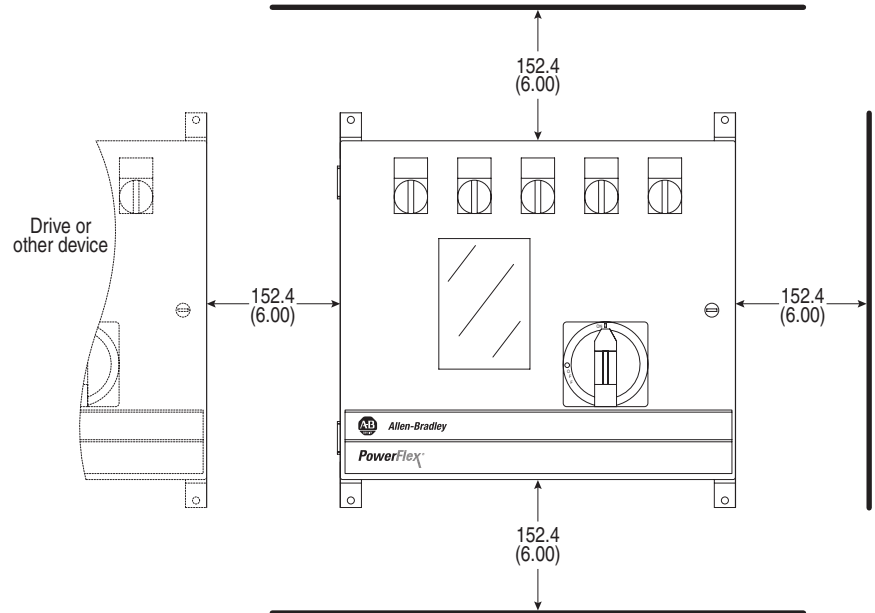

Dimensions

Figure 23 - Frame B Dimensions
 Dimensions are in millimeters and (inches).

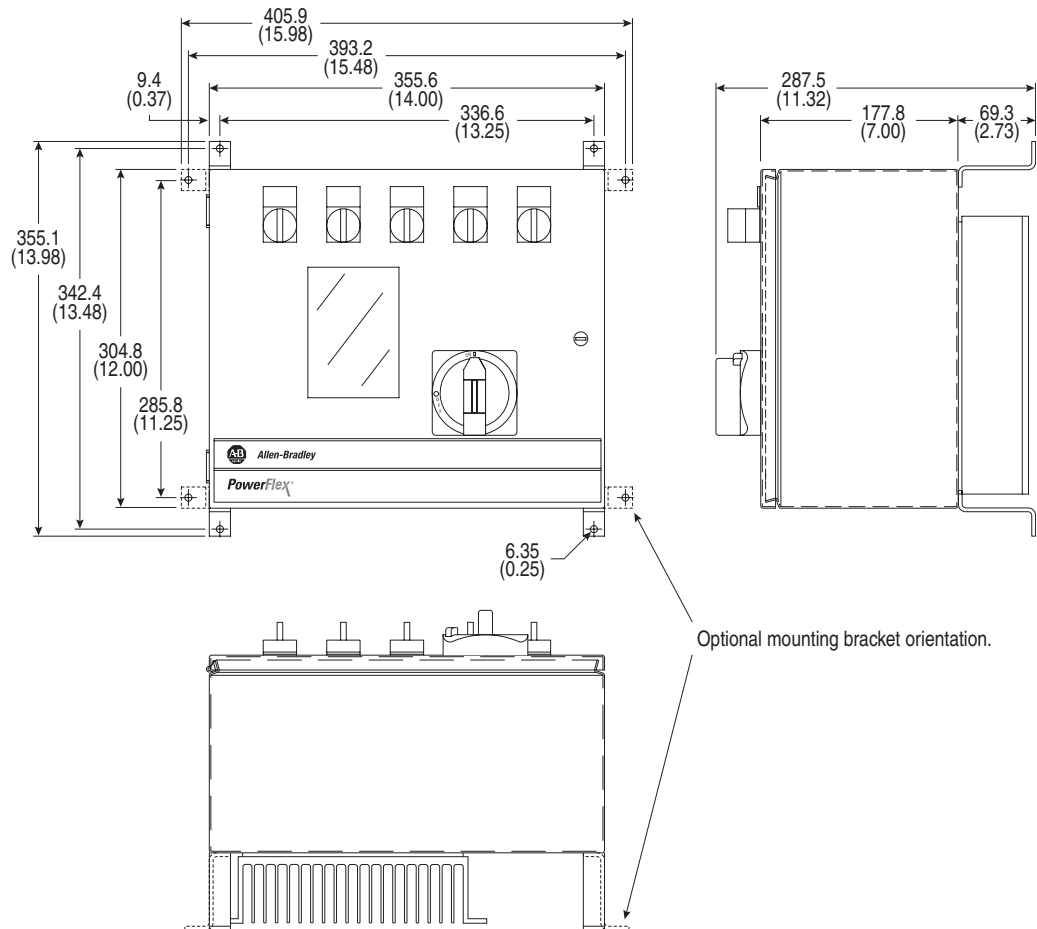

Figure 24 - Frame C Dimensions
 Dimensions are in millimeters and (inches).

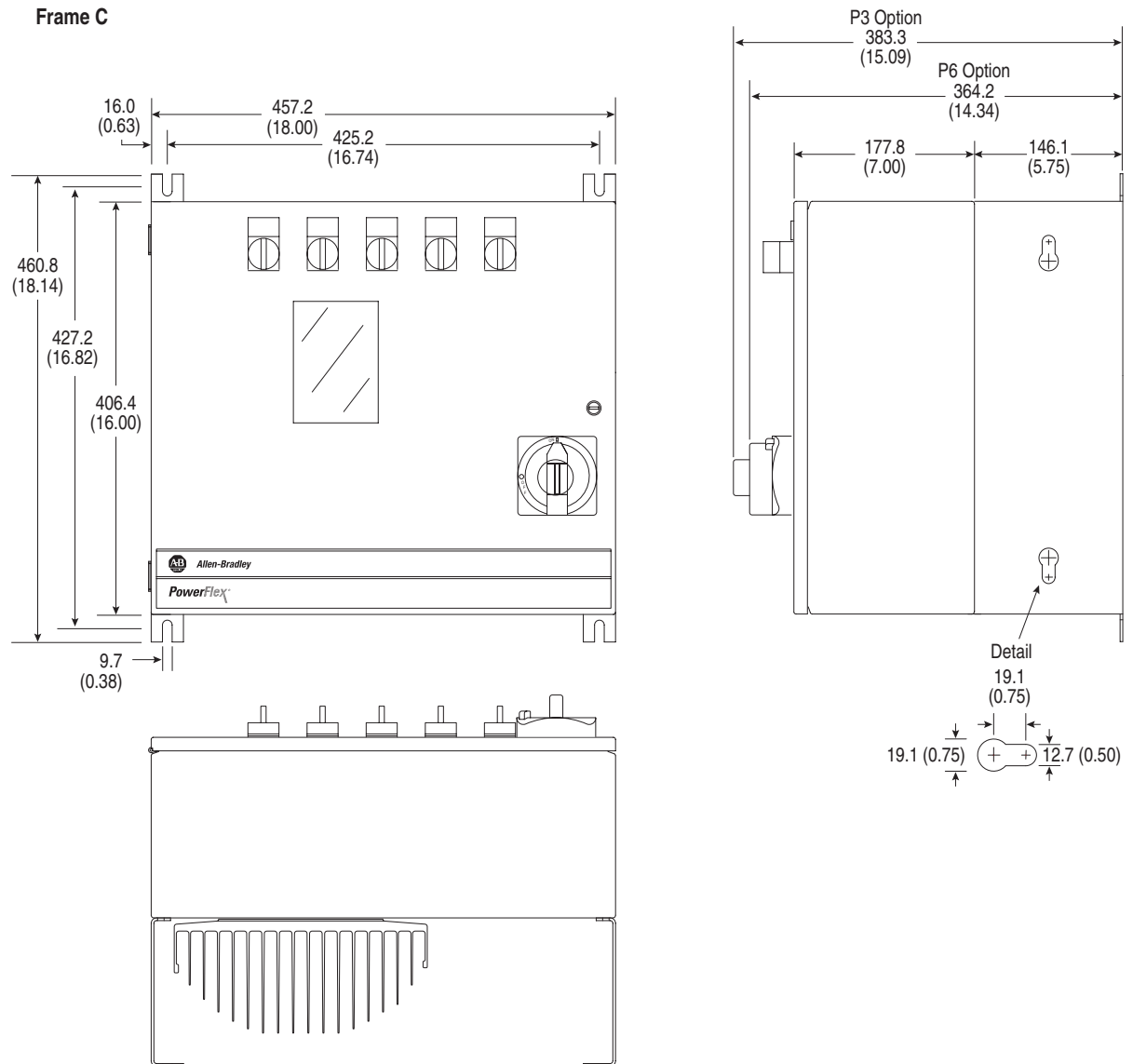

Figure 26 - PowerFlex 40 Frame C Layout Drawing

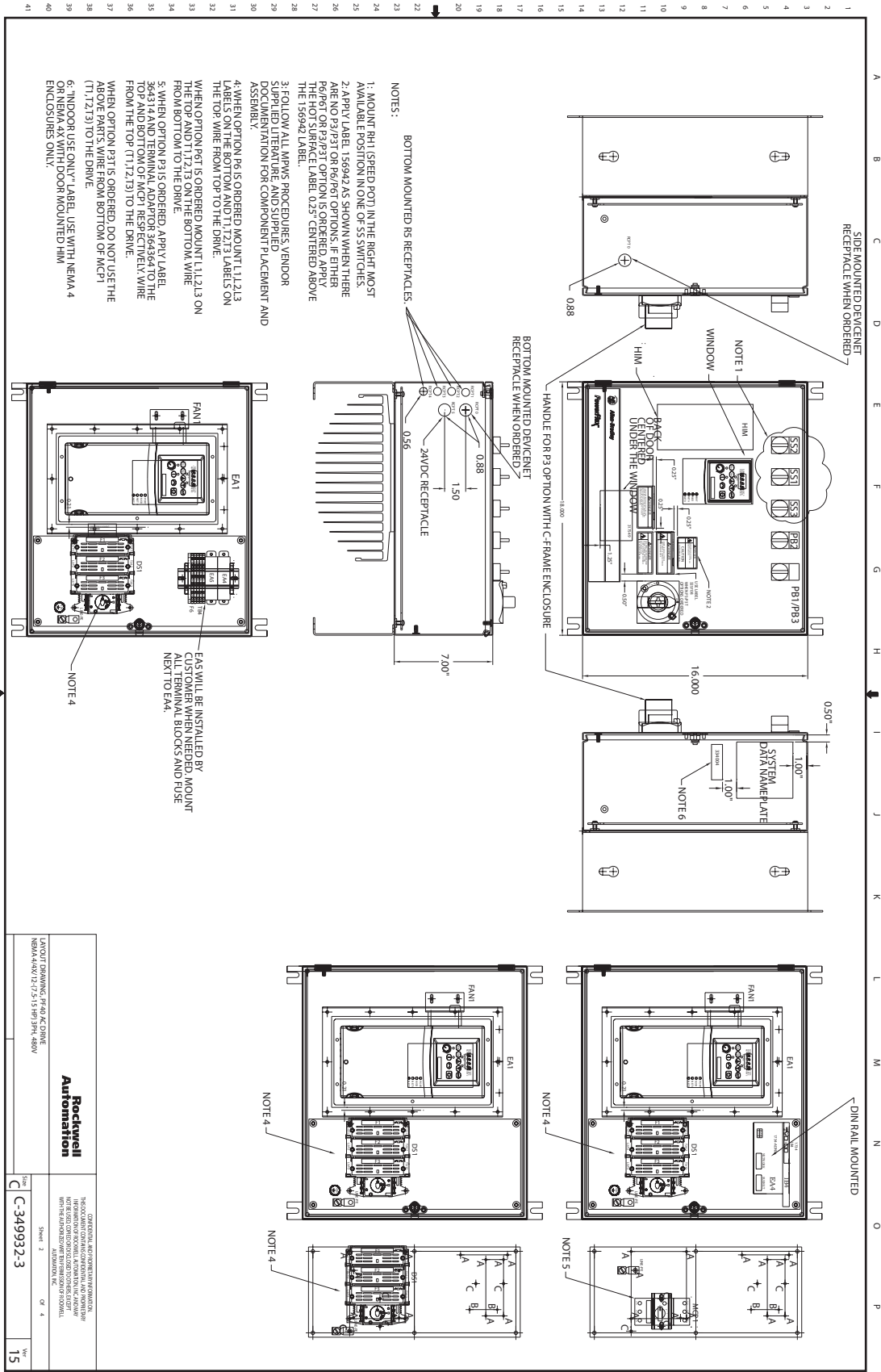
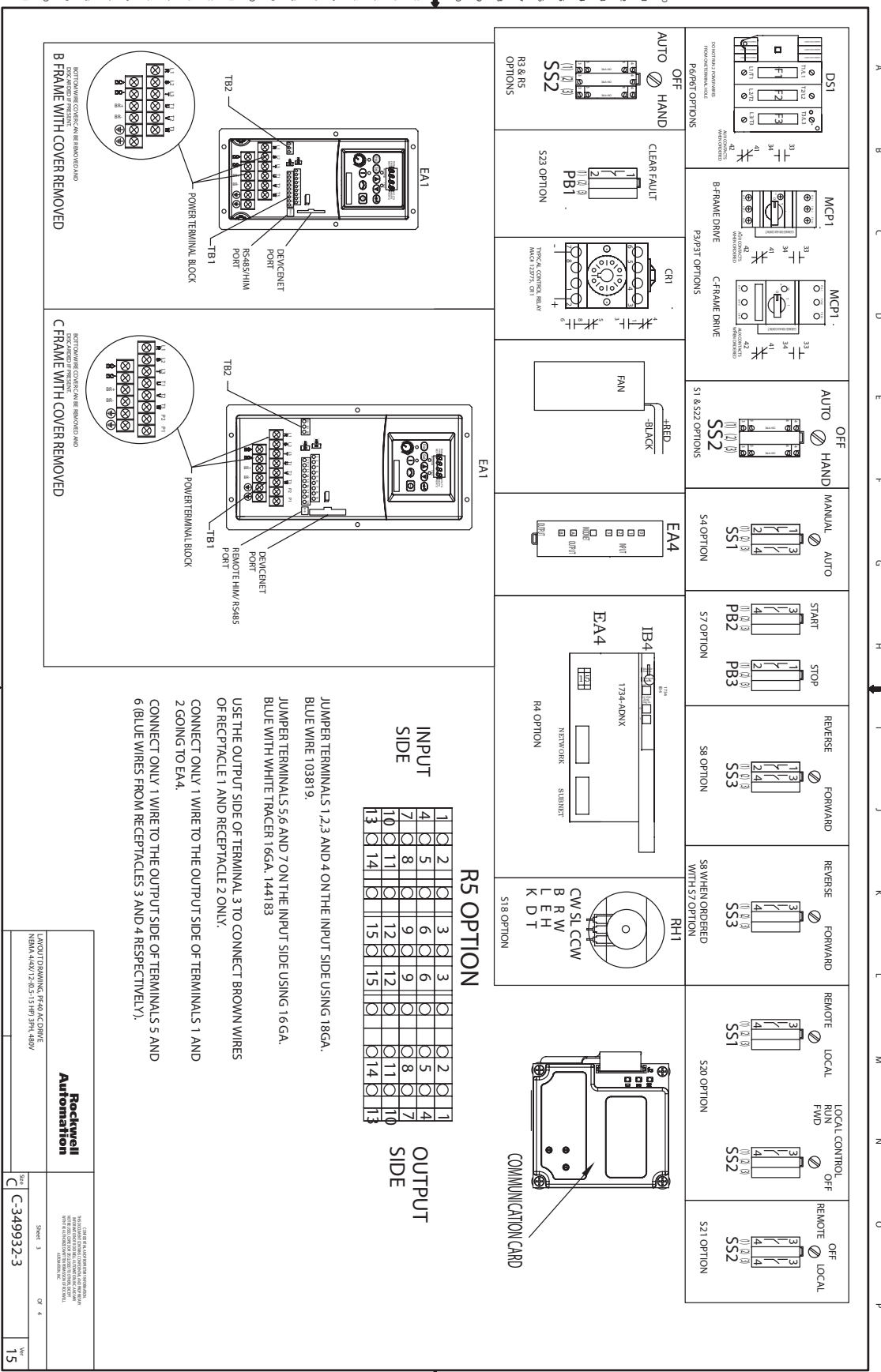



Figure 27 - PowerFlex 40 General Option Layout Drawing



Specifications

Table 5 - Standard Configured Drive Products

Input/Output Ratings	<i>Output Frequency:</i> 0...400 Hz (Programmable) <i>Efficiency:</i> 97.5% (Typical)
Approvals	
Fuses and Power Disconnecting Means	<i>140M Motor Circuit Protector:</i> Provides branch circuit protection, 65 kA short circuit withstand <i>194R Fused Disconnect:</i> Provides branch circuit protection, 100 kA short circuit withstand, Class J fuses
Protective Features	<i>Over Voltage:</i> 480V AC Input – Trip occurs at 810V DC bus voltage (equivalent to 575V AC incoming line) <i>Under Voltage:</i> 480V AC Input – Trip occurs at 390V DC bus voltage (equivalent to 275V AC incoming line)
Environment	<i>Ambient Operating Temperature, NEMA 4/12, 4X (IP66):</i> –10 to 40 degrees C (14 to 104 degrees F) ⁽¹⁾ <i>Cooling Method:</i> Fan (All drive ratings)
Control	<i>Carrier Frequency:</i> 2...4 kHz. Drive rating and heat calculations are based on 4 kHz.

(1) The design of the PowerFlex 40 Standard Configured Drive NEMA 4/12 and 4X packages support indoor and outdoor applications that are not in direct sunlight. When optional Door Mounted HIM is supplied, enclosure is rated for indoor use only.

Table 6 - Standard PowerFlex 40 Drives



Digital Control Inputs (Input Current = 6 mA)	<i>SRC (Source) Mode:</i> 18...24 Volts = ON; 0...6 Volts = OFF <i>SNK (Sink) Mode:</i> 0...6 Volts = ON; 18...24 Volts = OFF
Analog Control Inputs	<i>4-20mA Analog:</i> 250 ohm input impedance <i>0-10V DC Analog:</i> 100k ohm input impedance <i>External Pot:</i> 1...10k ohms, 2 Watt minimum
Control Output	<i>Programmable Output (form C relay)</i> <i>Resistive Rating:</i> 3.0A at 30V DC, 3.0A at 125V AC, 3.0A at 240V AC <i>Inductive Rating:</i> 0.5A at 30V DC, 0.5A at 125V AC, 0.5A at 240V AC <i>Opto Outputs</i> 30V DC, 50 mA <i>Analog Output (10-bit)</i> 0-10V, 1k ohm Min. Non-inductive
Fuses and Circuit Breakers	<i>Recommended Fuse Type:</i> UL Class J, CC, T or Type BS88; 600V (550V) or equivalent. <i>Recommended Circuit Breakers:</i> HMCP circuit breaker or equivalent.
Protective Features	<i>Motor Protection:</i> I ² t overload protection – 150% for 60 Secs, 200% for 3 Secs (Provides Class 10 protection) <i>Overcurrent:</i> 200% hardware limit, 300% instantaneous fault <i>Control Ride Through:</i> Minimum ride through is 0.5 Secs - typical value 2 Secs <i>Faultless Power Ride Through:</i> 100 milliseconds
Dynamic Braking	Internal brake IGBT included with all ratings
Environment	<i>Altitude:</i> 1000 m (3300 ft) max. without derating <i>Storage Temperature:</i> –40 to 85 degrees C (–40 to 185 degrees F) <i>Atmosphere:</i> Important: Drive must not be installed in an area where the ambient atmosphere contains volatile or corrosive gas, vapors or dust. If the drive is not going to be installed for a period of time, it must be stored in an area where it will not be exposed to a corrosive atmosphere. <i>Relative Humidity:</i> 0 to 95% non-condensing <i>Shock (operating):</i> 15G peak for 11ms duration (±1.0ms) <i>Vibration (operating):</i> 1G peak, 5 to 2000 Hz
Control	<i>Frequency Accuracy</i> <i>Digital Input:</i> Within ±0.05% of set output frequency. <i>Analog Input:</i> Within 0.5% of maximum output frequency. <i>Analog Output:</i> ±2% of full scale, 10-bit resolution <i>Speed Regulation - Open Loop with Slip Compensation:</i> ±2% of base speed across a 40:1 speed range. 1% of base speed across a 60:1 speed range. <i>Stop Modes:</i> Multiple programmable stop modes including - Ramp, Coast, DC-Brake, Ramp-to-Hold and S Curve. <i>Accel/Decel:</i> Two independently programmable accel and decel times. Each time may be programmed from 0...600 seconds in 0.1 second increments. <i>Intermittent Overload:</i> 150% Overload capability for up to 1 minute; 200% Overload capability for up to 3 seconds <i>Electronic Motor Overload Protection:</i> Class 10 protection with speed sensitive response.

Notes:

Replacement Parts

Table 7 - Components

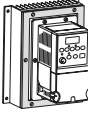
Description	Designation	Voltage	HP	Part Number	Manufacturer
Motor Circuit Protector Option P3 or P3T	MCP1	480V AC	0.5	140M-C2E-B40 ⁽²⁾	Allen-Bradley
			1.0	140M-C2E-B63 ⁽²⁾	Allen-Bradley
			2.0	140M-D8E-C10 ⁽²⁾	Allen-Bradley
			3.0	140M-D8E-C16 ⁽²⁾	Allen-Bradley
			5.0	140M-D8E-C25 ⁽²⁾	Allen-Bradley
			7.5	140M-F8E-C25 ⁽²⁾	Allen-Bradley
			10	140M-F8E-C32 ⁽²⁾	Allen-Bradley
			15	140M-F8E-C45 ⁽²⁾	Allen-Bradley
Replacement Kit ⁽¹⁾ Option P3	MCP1	480V AC	0.5	363326	Allen-Bradley
			1.0	363333	Allen-Bradley
			2.0	363337	Allen-Bradley
			3.0	363341	Allen-Bradley
			5.0	363345	Allen-Bradley
			7.5	363349	Allen-Bradley
			10	363353	Allen-Bradley
			15	363357	Allen-Bradley
Operator Handle Option P3 or P3T	MCP1	480V AC	0.5...5	190-HS4	Allen-Bradley
			7.5...15	140M-C-DN66	Allen-Bradley
Operator Handle Adaptor Option P3 or P3T	MCP1	480V AC	0.5...15	140M-D-HA	Allen-Bradley
Operator Shaft Option P3 or P3T	MCP1	480V AC	0.5...5	194R-NX12	Allen-Bradley
			7.5...15	140M-C-DS	Allen-Bradley
Operator Terminal Markings	MCP1	480V AC	0.5...5.0	A46006-086-01 ⁽²⁾ 140M-C-TE ⁽²⁾	Allen-Bradley Allen-Bradley
			7.5...15	A46006-091-01 ⁽²⁾ 140M-F-TE ⁽²⁾	Allen-Bradley Allen-Bradley
Disconnect Switch Option P6 or P6T	DS1	480V AC	0.5...10	194R-J30-1753	Allen-Bradley
			15	194R-J60-1753	Allen-Bradley
Operator Handle Option P6 or P6T	DS1	480V AC	0.5...15	194R-HS4	Allen-Bradley
Operator Shaft Option P6 or P6T	DS1	480V AC	0.5...15	194R-R1	Allen-Bradley

Description	Designation	Voltage	HP	Part Number	Manufacturer	
Main Fuses Option P6 or P6T	F1, F2, F3	480V AC	0.5	LPJ-3SP	Bussman	
				AJT-3	Ferraz-Shawmut	
			1.0	LPJ-6SP	Bussman	
				2.0	LPJ-10	Bussman
					LPJ-10SP	Bussman
			3.0	AJT-10	Ferraz-Shawmut	
				5.0	LPJ-15	Bussman
					LPJ-15SP	Bussman
			7.5	LPJ-20	Bussman	
					LPJ-20SP	Bussman
				AJT-20	Ferraz-Shawmut	
			10	LPJ-25	Bussman	
					LPJ-25SP	Bussman
				AJT-25	Ferraz-Shawmut	
			15	LPJ-30	Bussman	
					LPJ-30SP	Bussman
AJT-30	Ferraz-Shawmut					
LPJ-50	Bussman					
	LPJ-50SP	Bussman				
Drive Module (with Heatsink) 	EA1	480V AC	0.5	22B-D1P4F104	Allen-Bradley	
				22B-D2P3F104	Allen-Bradley	
			2.0	22B-D4P0F104	Allen-Bradley	
				22B-D6P0F104	Allen-Bradley	
			5.0	22B-D010F104	Allen-Bradley	
				22B-D012F104	Allen-Bradley	
			10	22B-D017F104	Allen-Bradley	
				22B-D024F104	Allen-Bradley	
Drive Module (Plate Drive) 	EA1	480V AC	0.5	22B-D1P4H204	Allen-Bradley	
				22B-D2P3H204	Allen-Bradley	
			2.0	22B-D4P0H204	Allen-Bradley	
				22B-D6P0H204	Allen-Bradley	
			5.0	22B-D010H204	Allen-Bradley	
				22B-D012H104	Allen-Bradley	
			10	22B-D017H104	Allen-Bradley	
				22B-D024H104	Allen-Bradley	

(1) Replacement Kit includes Motor Circuit Protector and top and bottom terminal labels/instructions. Does not include handle, adaptor, or connection rod.

(2) Part of Motor Circuit Protector Replacement Kit.

Table 8 - Communication Options

Description	Designation	Voltage	HP	Part Number	Manufacturer
ControlNet	EA1	All	All	22-COMM-C	Allen-Bradley
DeviceNet	EA1	All	All	22-COMM-D	Allen-Bradley
EtherNet	EA1	All	All	22-COMM-E	Allen-Bradley
PROFIBUS	EA1	All	All	22-COMM-P	Allen-Bradley
Adaptor					
Frame B	EA1	All	0.5...5.0	22B-CCB	Allen-Bradley
Frame C	EA1	All	7.5...15	22B-CCC	Allen-Bradley

Table 9 - Quick Disconnect Options

Description	Designation	Voltage	HP	Part Number	Manufacturer
DeviceNet - Bottom	E22	All	All	41358N	Brad Harrison
DeviceNet - L Side	E23	All	All	41358N	Brad Harrison

Table 10 - HIM Options

Description	Designation	Voltage	HP	Part Number	Manufacturer
Door Mounted		All	All	22-HIM-C2S	Allen-Bradley
IP 66 (NEMA/UL Type)					

Table 11 - Operator Devices/Control Options

Option	Description	Designation	Voltage	HP	Part Number	Manufacturer
Option S1	Selector Switch	SS2	All	All	800FP-SM32	Allen-Bradley
	Mounting Latch	SS2			800F-ALP	Allen-Bradley
	Contact Block - 4 N.O.	SS2			800F-X10	Allen-Bradley
	Legend Plate	SS2			354614	Allen-Bradley ⁽⁵⁾
Option S4	Selector Switch	SS1	All	All	800FP-SM22	Allen-Bradley
	Mounting Latch	SS1			800F-ALP	Allen-Bradley
	Contact Block - 1 N.O.	SS1			800F-X10	Allen-Bradley
	Contact Block - 1 N.C.	SS1			800F-X01	Allen-Bradley
	Legend Plate	SS1		354650	Allen-Bradley ⁽⁵⁾	
Option S7	Push Button (Green)	PB2	All	All	800FP-F3	Allen-Bradley
	Push Button (Red)	PB3			800FP-E4	Allen-Bradley
	Mounting Latch	PB2, PB3			800F-ALP	Allen-Bradley
	Contact Block - 1 N.O.	PB2			800F-X10	Allen-Bradley
	Contact Block - 1 N.C.	PB3			800F-X01	Allen-Bradley
	Legend Plate	PB2			354666	Allen-Bradley ⁽⁵⁾
Legend Plate	PB3	354859	Allen-Bradley ⁽⁵⁾			
Option S8	Selector Switch	SS3	All	All	800FP-SM22	Allen-Bradley
	Mounting Latch	SS3			800F-ALP	Allen-Bradley
	Contact Block - 1 N.O.	SS3			800F-X10	Allen-Bradley
	Contact Block - 1 N.C.	SS3			800F-X01 ⁽⁴⁾	Allen-Bradley
	Legend Plate	SS3		354662	Allen-Bradley ⁽⁵⁾	
Option S18	Potentiometer/Operator	RH1	All	All	800F-POT6	Allen-Bradley
	Legend Plate	RH1			362657	Allen-Bradley ⁽⁵⁾
Option S20	Selector Switch	SS1, SS2	All	All	800FP-SM22	Allen-Bradley
	Mounting Latch	SS1, SS2			800F-ALP	Allen-Bradley
	Contact Block - 1 N.O.	SS1, SS2			800F-X10	Allen-Bradley
	Legend Plate	SS1			354702	Allen-Bradley ⁽⁵⁾
	Legend Plate	SS2		354786	Allen-Bradley ⁽⁵⁾	

Option	Description	Designation	Voltage	HP	Part Number	Manufacturer
Option S21	Selector Switch	SS2	All	All	800FP-SM32	Allen-Bradley
	Anti-Rotation Switch	SS2			800F-ALC1	Allen-Bradley
	Mounting Latch	SS2			800F-ALP	Allen-Bradley
	Contact Block - 2 N.O.	SS2			800F-X10	Allen-Bradley
	Legend Plate	SS2			354769	Allen-Bradley ⁽⁵⁾
	MOV	CR1			V130LA10A	Harris
	Relay	CR1			700-HA 32A1	Allen-Bradley
	Relay Socket (Base)	CR1			700-HN125	Allen-Bradley
Relay Retainer Clip	CR1	700HN159	Allen-Bradley			
Option S22	Selector Switch	SS2	All	All	800FP-SL32	Allen-Bradley
	Mounting Latch	SS2			800F-ALP	Allen-Bradley
	Contact Block - 1 N.O.	SS2			800F-X10	Allen-Bradley
	Legend Plate	SS2			354614	Allen-Bradley ⁽⁵⁾
Option S23	Push Button (Black)	PB1	All	All	800FP-F2	Allen-Bradley
	Mounting Latch	PB1			800F-ALP	Allen-Bradley
	Contact Block - 1 N.O.	PB1			800F-X10	Allen-Bradley
	Legend Plate	PB1			382966	Allen-Bradley ⁽⁵⁾
Option R3/R5	Selector Switch	SS2	All	All	800FP-SL32CR	Allen-Bradley
	Aux Contact - 1 N.O./1 N.C. ⁽¹⁾	DS1			800F-X11D	Allen-Bradley
	Aux Contact ⁽²⁾	MCP1			140M-C-ASA11	Allen-Bradley
	Contact Block - 5 N.O.	SS2			800F-X10	Allen-Bradley
	Legend Plate	SS2			354614	Allen-Bradley ⁽⁵⁾
	I/O Module	EA4			100-DNY42R	Allen-Bradley
	Quick Disconnect ⁽³⁾	RCPT1-RCPT4			888D-F4AC2-1	Allen-Bradley
	Quick Disconnect ⁽³⁾	RCPT5			888D-M4AE1-1	Allen-Bradley
	Terminal Block ⁽³⁾	TB4			1492-WTF3	Allen-Bradley
	Fuse Block ⁽³⁾	F6			1492-H6	Allen-Bradley
Fuse ⁽³⁾	F6	MDA-3	Bussmann			
Option R4	DeviceNet Adaptor	EA4	All	All	1734-ADNX	Allen-Bradley
	Point I/O Terminal Base	EA4			1734-TB3SQ10	Allen-Bradley
	Input I/O Module	IB4			1734-IB4	Allen-Bradley

- (1) P6 and P6T option only.
- (2) P3 and P3T option only.
- (3) R5 option only.
- (4) Option S8 when S7 is not ordered.
- (5) Legend plates are not stocked for general sale. A custom quote is required to purchase.

Table 12 - Miscellaneous

Description	Designation	Voltage	HP	Part Number	Manufacturer
Fan	FAN	All	0.5 . . . 5.0	2410ML-05W-B30-B00	NMB Tech

Rockwell Automation Support

Rockwell Automation provides technical information on the Web to assist you in using its products.

At <http://www.rockwellautomation.com/support>, you can find technical manuals, technical and application notes, sample code and links to software service packs, and a MySupport feature that you can customize to make the best use of these tools. You can also visit our Knowledgebase at <http://www.rockwellautomation.com/knowledgebase> for FAQs, technical information, support chat and forums, software updates, and to sign up for product notification updates.

For an additional level of technical phone support for installation, configuration, and troubleshooting, we offer TechConnect support programs. For more information, contact your local distributor or Rockwell Automation representative, or visit <http://www.rockwellautomation.com/support/>.

Installation Assistance

If you experience a problem within the first 24 hours of installation, review the information that is contained in this manual. You can contact Customer Support for initial help in getting your product up and running.

United States or Canada	1.440.646.3434
Outside United States or Canada	Use the Worldwide Locator at http://www.rockwellautomation.com/support/americas/phone_en.html , or contact your local Rockwell Automation representative.

New Product Satisfaction Return

Rockwell Automation tests all of its products to ensure that they are fully operational when shipped from the manufacturing facility. However, if your product is not functioning and needs to be returned, follow these procedures.

United States	Contact your distributor. You must provide a Customer Support case number (call the phone number above to obtain one) to your distributor to complete the return process.
Outside United States	Please contact your local Rockwell Automation representative for the return procedure.

Documentation Feedback

Your comments will help us serve your documentation needs better. If you have any suggestions on how to improve this document, complete this form, publication [RA-DU002](#), available at <http://www.rockwellautomation.com/literature/>.

www.rockwellautomation.com



PN-145136

Power, Control and Information Solutions Headquarters

Americas: Rockwell Automation, 1201 South Second Street, Milwaukee, WI 53204-2496 USA, Tel: (1) 414.382.2000, Fax: (1) 414.382.4444

Europe/Middle East/Africa: Rockwell Automation NV, Pegasus Park, De Kleetlaan 12a, 1831 Diegem, Belgium, Tel: (32) 2 663 0600, Fax: (32) 2 663 0640

Asia Pacific: Rockwell Automation, Level 14, Core F, Cyberport 3, 100 Cyberport Road, Hong Kong, Tel: (852) 2887 4788, Fax: (852) 2508 1846

Publication 23B-IN001H-EN-P - February 2012

Supersedes Publication 23B-IN001G-EN-P - May 2008

Copyright © 2012 Rockwell Automation, Inc. All rights reserved. Printed in the U.S.A.