

# **PanelMate Series 1000 Product Manual**

---

**Cutler-Hammer IDT  
P.O. Box 6166  
Westerville, OH 43081-6166  
(614) 882-3282**



# Preface

---

Cutler-Hammer IDT has prepared this manual for use by Cutler-Hammer IDT personnel and customers. The information contained within is the property of Cutler-Hammer IDT and shall not be reproduced in whole or part without written approval from Cutler-Hammer IDT.

The material in this manual is for informational purposes only and is subject to change without notice.

Cutler-Hammer IDT assumes no responsibility for any errors that may appear in this manual.

The following are trademarks of Cutler-Hammer IDT and are not to be reproduced nor used in any fashion without written approval from Cutler-Hammer IDT. All rights reserved.

PanelMate®

PanelMate Series 1000™

TouchPanel™

IBM-PC, IBM-XT and PS/2 are registered trademarks of International Business Machines Corporation.

Microsoft is a registered trademark of Microsoft Corporation.

Windows is a trademark of Microsoft Corporation.

Any reference to trademark and/or copyrighted material is unintentional.

© Cutler-Hammer IDT, 1996

Printed in the USA



# Table of Contents

---

<b>Chapter 1</b>	
<b>Introduction</b> .....	<b>1-1</b>
How to use this Manual .....	1-2
Typographical Conventions .....	1-3
Manual Organization .....	1-3
<b>Chapter 2</b>	
<b>Overview</b> .....	<b>2-1</b>
Benefits .....	2-2
Product Description .....	2-4
PanelMate Online System .....	2-4
DOS-based Configuration Software Package .....	2-5
Special Features of the Configuration Mode Package .....	2-5
Template Mode .....	2-7
Run Mode .....	2-8
System Overview Field .....	2-9
Hardware Description .....	2-9
Editing Standards .....	2-10
Data Fields .....	2-10
Option Window .....	2-10
Help Pages .....	2-11
Fonts .....	2-11
<b>Chapter 3</b>	
<b>How to Successfully Develop Your Application</b> .....	<b>3-1</b>
Basic Steps for Creating a Successful Application .....	3-2
Defining the Scope of the Project .....	3-2
Defining the Page Layout .....	3-3
Enhancing Operator Performance .....	3-4
Gathering Information for Configuration .....	3-5
<b>Chapter 4</b>	
<b>Hardware Checkout Overview</b> .....	<b>4-1</b>
Unpacking .....	4-2
Check System Health .....	4-3
Connect DC Power .....	4-5
Power Up the Unit .....	4-5
Demonstration Program .....	4-5
Execute the System Diagnostics .....	4-6
Execute Tests .....	4-6
Enter the Transfer Mode .....	4-7
Enter Run Mode .....	4-8

Display System Info .....	4-8
<b>Chapter 5</b>	
<b>Installation in an Industrial Enclosure .....</b>	<b>5-1</b>
Installation in an Industrial Enclosure .....	5-2
PanelMate Series 1000 Enclosure Sizing .....	5-2
Install PanelMate Series 1000 in Enclosure .....	5-10
Connect DC Power .....	5-10
Connection to the Serial Port .....	5-11
Connection to a Personal Computer .....	5-11
<b>Chapter 6</b>	
<b>Online Operation .....</b>	<b>6-1</b>
Power-up Sequence .....	6-2
Execute Normal Power-up Diagnostics .....	6-2
Run Mode Initialization .....	6-3
Run Mode Operation .....	6-4
Page Title Line .....	6-4
System Overview .....	6-4
Default Control Button Labels .....	6-5
Call a New Page .....	6-6
Adjusting the Contrast .....	6-6
PLC Page Selection .....	6-6
Operator Input .....	6-7
Alarms .....	6-7
Alarm Page .....	6-8
Password Protection .....	6-9
Errors During Run Mode .....	6-10
Communication Errors .....	6-10
System Errors .....	6-13
<b>Chapter 7</b>	
<b>Regular Maintenance .....</b>	<b>7-1</b>
Regular Maintenance .....	7-2
<b>Chapter 8</b>	
<b>Troubleshooting Guide for the PanelMate Series System .....</b>	<b>8-1</b>
Problems with the Monitor .....	8-2
Problems with the TouchPanel .....	8-2
Problems with the Control Buttons .....	8-2
Problems with Audio Output .....	8-2
Problems with Serial Port .....	8-3
Problems when Transferring Memory .....	8-3
Specific Error Messages .....	8-4

<b>Chapter 9</b>	
<b>Initialization of the Configuration Software Package</b>	<b>9-1</b>
Overview	9-2
Personal Computer Hardware Requirements	9-2
Running the Setup Installation Program	9-3
Starting the Configuration Software Package	9-4
File Naming Conventions and File Management	9-4
Non-VGA Hardware	9-4
<b>Chapter 10</b>	
<b>Basic Steps for Creating a User Configuration</b>	<b>10-1</b>
Overview of the Process	10-2
Step One: Create a User Configuration	10-2
Step Two: Transfer Files to the PanelMate Unit	10-4
Step Three: Connect the PanelMate Unit to your PLC	10-4
Notes on Online Operation	10-5
Word and Bit References	10-7
Word References	10-7
PLC Bit References	10-9
<b>Chapter 11</b>	
<b>The Main Menu</b>	<b>11-1</b>
The Main Menu	11-2
Develop a Configuration	11-2
Transfer Information	11-2
Perform File Management	11-2
Verify a Configuration	11-3
Edit Utility Parameters	11-4
Display Help Page	11-7
Exit to Dos	11-7
<b>Chapter 12</b>	
<b>The User Configuration Editor</b>	<b>12-1</b>
The Develop Configuration Menu	12-2
Edit an Existing Configuration	12-2
Create a New Configuration	12-3
The Configuration Editor Menu	12-4
Display Configuration	12-5
Select International Font	12-6
Merge Configuration	12-6
<b>Chapter 13</b>	
<b>Directory Editor</b>	<b>13-1</b>
Before You Start Configuring Pages	13-2
Functions of the Directory Editor	13-2
Enter Directory Editor	13-3

Access the Page Editor .....	13-3
Protection .....	13-3
Page Title .....	13-4
Swap .....	13-4
Move .....	13-4
Copy .....	13-5
Delete .....	13-5
Memory Free .....	13-5
Exit .....	13-5

## Chapter 14

<b>Page Editor .....</b>	<b>14-1</b>
Configuring the PanelMate unit .....	14-2
Page Layout .....	14-2
Page Editor Main Menu .....	14-3
Page Editor in Template Mode .....	14-3
Edit a Template Definition <F1> .....	14-4
Add a Template <F2> .....	14-4
Move a Template <F3> .....	14-4
Copy a Template <F4> .....	14-5
Delete a Template <F5> .....	14-5
Memorize <F7>/Recall <F8> Template .....	14-6
Save <F9> .....	14-6
Exit the Template Mode <F10> .....	14-6
Page Editor in the Message Mode .....	14-7
Save the Page .....	14-7
Exit the Page Editor .....	14-7

## Chapter 15

<b>Indicator Template Editor .....</b>	<b>15-1</b>
Functions of Indicator Templates .....	15-2
Template Size .....	15-3
Character Size .....	15-3
Device Name .....	15-3
Template Definition Table .....	15-3
Control Button Definition Table .....	15-5
Editing Existing Templates .....	15-6
Exit the Indicator Template Editor .....	15-6
Gathering Information for Configuration .....	15-6

## Chapter 16

<b>Readout Template Editor .....</b>	<b>16-1</b>
Functions of Readout Templates .....	16-2
Template Size/Character Size .....	16-3
Decimal Places .....	16-3
Device Name .....	16-3

Value Expression .....	16-3
High Alarm Expression .....	16-4
Low Alarm Expression .....	16-4
Deadband Range .....	16-4
Alarm Acknowledgment .....	16-5
Control Type .....	16-5
Numeric Control Definition .....	16-5
Control Button Definition Table .....	16-6
Editing Existing Templates .....	16-7
Exit the Readout Template Editor .....	16-7
Gathering Information for Configuration .....	16-7
<b>Chapter 17</b>	
<b>Bar Template Editor .....</b>	<b>17-1</b>
Functions of Bar Templates .....	17-2
Template Size .....	17-3
Device Name .....	17-3
Units .....	17-4
Maximum Calibration .....	17-4
Minimum Calibration .....	17-4
Actual Value Expression .....	17-4
Setpoint Value Expression .....	17-5
High Alarm Expression .....	17-5
Low Alarm Expression .....	17-5
Deadband Range .....	17-6
Alarm Acknowledgment .....	17-6
Control Type .....	17-6
Numeric Control Definition .....	17-7
Control Button Definition Table .....	17-8
Editing Existing Templates .....	17-9
Exit the Bar Template Editor .....	17-9
Gathering Information for Configuration .....	17-9
<b>Chapter 18</b>	
<b>Display Template Editor .....</b>	<b>18-1</b>
Functions of Display Templates .....	18-2
Template Type .....	18-3
Message Expression .....	18-3
Test Display .....	18-3
Control Button Definition Table .....	18-4
Editing Existing Templates .....	18-4
Exit the Display Template Editor .....	18-4
Gathering Information for Configuration .....	18-5
<b>Chapter 19</b>	
<b>Message Library Editor .....</b>	<b>19-1</b>

Message Library .....	19-2
Register References Within Messages .....	19-3
Save <F9> .....	19-7
Exit the Message Library Editor .....	19-7
Gathering Information for Configuration .....	19-7

## Chapter 20

<b>Table Template Editor .....</b>	<b>20-1</b>
Functions of Table Templates .....	20-2
Template Size .....	20-3
Device Name .....	20-3
Parameter Tag .....	20-3
Current Value Tag .....	20-3
Edit Value Tag .....	20-3
Password Protection .....	20-3
Table Entry Definition Table .....	20-4
Parameter Column .....	20-4
Value Expression Column .....	20-4
Dec. Pt. ....	20-5
Target Word Address Column .....	20-5
Editing Existing Templates .....	20-5
Exit the Table Template Editor .....	20-5
Gathering Information for Configuration .....	20-5

## Chapter 21

<b>Maintenance Template Editor .....</b>	<b>21-1</b>
Functions of Maintenance Templates .....	21-2
Template Size .....	21-3
Write Privilege .....	21-3
Default PLC Reference .....	21-4
Data Format .....	21-4
Password Protection .....	21-4
Editing Existing Templates .....	21-4
Exit the Maintenance Template Editor .....	21-4
Gathering Information for Configuration .....	21-5
Online Operation of the Maintenance Template .....	21-7
Stop Monitor .....	21-7
Change Value .....	21-7
Modify Template .....	21-7

## Chapter 22

<b>Defining System Parameters .....</b>	<b>22-1</b>
Edit System Parameters .....	22-2
Immediate Page Change .....	22-2
Control Bit Reset .....	22-2
Bit Zero After Com Fault .....	22-3

Retry Delay .....	22-3
Passwords .....	22-3
Remote Alarm Acknowledge Bit .....	22-4
Page Change Register .....	22-4
Remote Silence Alarm Horn Bit .....	22-4
Startup Page Number .....	22-5
Inactivity Periods .....	22-5
Audio Output .....	22-5
Exit .....	22-5

## Chapter 23

<b>PLC Name and Port Parameters Table .....</b>	<b>23-1</b>
Edit PLC Name and Port Table .....	23-2
Use .....	23-2
Network ID# (PanelMate Port Parameter) .....	23-3
Data Bits .....	23-3
Stop Bits .....	23-3
Parity .....	23-3
Baud Rate .....	23-3
Electrical (Elect.) .....	23-4
Name .....	23-4
ID# (PLC Name Table) .....	23-4
Model .....	23-4
Default PLC Name Field .....	23-4
Screen Scan Delay .....	23-5
Alarm Scan Delay .....	23-5
Message Scan Delay .....	23-5
Remote I/O Configuration .....	23-6
Active Rack Table .....	23-7
Active Block Transfer Table .....	23-7
Data Highway 485 .....	23-8

## Chapter 24

<b>System Online Labels Editor .....</b>	<b>24-1</b>
System Online Labels (Online Label Alternatives) .....	24-2
Miscellaneous Soft Key Prompts 1 .....	24-3
Miscellaneous Soft Key Prompts 2 .....	24-3
Maintenance Template Soft Key Prompts .....	24-4
Error Messages .....	24-4
Miscellaneous Text .....	24-5
Alarm Text .....	24-5

## Chapter 25

<b>Print Documentation .....</b>	<b>25-1</b>
Print Documentation .....	25-2

<b>Chapter 26</b>	
<b>Transfer Editor</b> .....	<b>26-1</b>
Overview .....	26-2
Preparing to Transfer .....	26-3
The Transfer Information Menu .....	26-4
Download Configuration to VCP Unit .....	26-4
Upload Configuration from VCP Unit .....	26-7
Download Driver Firmware to VCP Unit .....	26-9
Download Option to VCP Unit .....	26-12
Read System Information from VCP Unit .....	26-14
Return to Main Menu .....	26-14
<b>Chapter 27</b>	
<b>File Management</b> .....	<b>27-1</b>
The File Management Menu .....	27-2
Copy a Configuration .....	27-2
Rename a Configuration .....	27-3
Delete a Configuration .....	27-4
Return to Main Menu .....	27-4
<b>Chapter 28</b>	
<b>Troubleshooting the Configuration Software Package</b> .....	<b>28-1</b>
Miscellaneous Error Messages .....	28-2
Configuration Software Startup Error Messages .....	28-2
Program/File Load Error Messages .....	28-3
Help Page Error Messages .....	28-4
Disk Access Error Messages .....	28-4
File Name Error Messages .....	28-6
<b>Chapter 29</b>	
<b>Allen-Bradley PLCs</b> .....	<b>29-1</b>
Memory .....	29-2
Possible Configurations .....	29-2
Serial Communication to One PLC .....	29-2
Data Highway Connections Using Serial Communication Modules .....	29-3
Multiple Data Highways Using Serial Communication .....	29-4
Direct Connection to Data Highway 485 .....	29-5
PLC-3 Data Access .....	29-6
PLC-5 Data Access .....	29-8
SLC 500 Data Access .....	29-10
Allen-Bradley Modules .....	29-10
Cabling .....	29-12
Communications Parameters .....	29-13
Modules for PLC Data Highway Connection .....	29-14
Modules for the PanelMate Data Highway Communication .....	29-16

Modules for Direct Connection .....	29-18
Modules for PanelMate to Data Highway Plus Connection .....	29-19
Modules to Connect PanelMate to Data Highway 485 .....	29-21
Allen-Bradley Word and Bit References .....	29-22
PLC-2 Word and Bit References .....	29-22
PLC-3 Word and Bit References .....	29-23
PLC-5 Word and Bit References .....	29-23
SLC 500 Word and Bit References .....	29-27
Access Permitted by Maintenance Template .....	29-34
Allen-Bradley Remote STS and EXT STS Errors .....	29-35

## Chapter 30

<b>The AcceleratI/On Interface .....</b>	<b>30-1</b>
Possible Configurations .....	30-2
Direct Data Highway Connections .....	30-2
Multiple Data Highway Connections .....	30-3
Direct Data Highway Plus Connections .....	30-3
Multiple Data Highway Plus Connections .....	30-4
Direct Data Highway and Data Highway Plus Connections .....	30-5
Remote I/O Connections .....	30-6
Cabling .....	30-7
Communication Parameters .....	30-8
Modules for SLC 5/02 Remote I/O Communication .....	30-8
Diagnostic Indicators .....	30-9
Allen-Bradley Word and Bit References .....	30-10
Data Highway and Data Highway Plus .....	30-10
Remote I/O .....	30-10
Active Racks .....	30-14
Block Transfers .....	30-15
Unsolicited Write Message .....	30-20
Access Permitted by Maintenance Template .....	30-22

## Chapter 31

<b>Cutler-Hammer PLCs .....</b>	<b>31-1</b>
Memory .....	31-2
Possible Configurations .....	31-4
Direct .....	31-4
Multiple .....	31-5
Cabling .....	31-5
Communications Parameters .....	31-6
CPU20 .....	31-6
CPU25 and CPU50 .....	31-7
D200 PR4C .....	31-9
Cutler-Hammer Word and Bit References .....	31-10
Register and Device References .....	31-10

CPU20 PLC ID Number Setting . . . . .	31-11
CPU25 and CPU50 PLC ID Number Settings . . . . .	31-11
D200 PR4C PLC ID Number Settings . . . . .	31-12
Access Permitted by Maintenance Template . . . . .	31-12

## Chapter 32

<b>General Electric PLCs . . . . .</b>	<b>32-1</b>
Memory . . . . .	32-2
Possible Configurations . . . . .	32-4
Direct . . . . .	32-4
Multidrop . . . . .	32-5
Cabling . . . . .	32-5
CCM2 . . . . .	32-6
Series Five . . . . .	32-7
Series Six and Six Plus . . . . .	32-8
Series 90 . . . . .	32-9
Communications Parameters . . . . .	32-9
PLC ID . . . . .	32-10
Switch Settings . . . . .	32-10
CCM . . . . .	32-10
CCM2 . . . . .	32-12
CCM3 . . . . .	32-13
I/O CCM . . . . .	32-13
General Electric Word and Bit References . . . . .	32-15
GE Series Five PLC Word and Bit References . . . . .	32-16
Series Six Word and Bit References . . . . .	32-17
GE Series Six Plus Word and Bit References . . . . .	32-23
GE Series 90 PLC Word and Bit References . . . . .	32-41
Access Permitted by Maintenance Template . . . . .	32-44

## Chapter 33

<b>Mitsubishi PLCs . . . . .</b>	<b>33-1</b>
Memory . . . . .	33-2
Mitsubishi A Series Memory Ranges . . . . .	33-3
Mitsubishi FX Series Memory Ranges . . . . .	33-6
Mitsubishi FXo Series Memory Ranges . . . . .	33-8
Possible Configurations . . . . .	33-10
Direct . . . . .	33-10
Network (Mitsubishi A Series only) . . . . .	33-11
Cabling . . . . .	33-12
Communications Parameters . . . . .	33-14
AJ71C24 Computer Link Module . . . . .	33-15
Mitsubishi Word and Bit References . . . . .	33-19
Access Permitted by Maintenance Template . . . . .	33-26

<b>Chapter 34</b>	
<b>Modicon Controllers</b> .....	<b>34-1</b>
Memory .....	34-2
Possible Configurations .....	34-2
Direct .....	34-2
Multiple PLCs on a Single Modbus .....	34-3
Cabling .....	34-4
Communications Parameters .....	34-5
984 and 584 Modbus Ports .....	34-5
884 Modbus Ports .....	34-6
Micro 84/J375 Modbus Adapter .....	34-7
484 PLC/J474 Modbus Communication Interface .....	34-9
Modicon Word and Bit References .....	34-11
Modicon Micro 84, 184, 384 and 484 .....	34-12
Modicon 584, 884 and 984 Register, Input and Coil References .....	34-13
Access Permitted by Maintenance Template .....	34-14
<b>Chapter 35</b>	
<b>Omron PLCs</b> .....	<b>35-1</b>
Memory .....	35-2
Possible Configurations .....	35-5
Direct .....	35-5
Network .....	35-6
Cabling .....	35-6
Communications Parameters .....	35-8
Communication Module .....	35-9
Omron Word and Bit References .....	35-11
Access Permitted by Maintenance Template .....	35-13
<b>Chapter 36</b>	
<b>Reliance AutoMate PLCs</b> .....	<b>36-1</b>
Memory .....	36-2
Possible Configurations .....	36-3
Direct .....	36-3
Serial Communications Card .....	36-4
Cabling .....	36-5
Communications Parameters .....	36-5
Serial Communications Card .....	36-6
R-Net Gateway .....	36-6
Reliance Word and Bit References .....	36-8
Access Permitted by Maintenance Template .....	36-9
<b>Chapter 37</b>	
<b>Siemens PLCs</b> .....	<b>37-1</b>
Memory .....	37-2

Possible Configurations . . . . .	37-4
Direct Connection . . . . .	37-4
Multiple Connection . . . . .	37-4
Cabling . . . . .	37-5
Communications Parameters . . . . .	37-5
Siemens Word, Byte, and Bit References . . . . .	37-6
Access Permitted by Maintenance Template . . . . .	37-15
<b>Chapter 38</b>	
<b>Square D PLCs . . . . .</b>	<b>38-1</b>
Memory . . . . .	38-2
Possible Configurations . . . . .	38-2
Direct . . . . .	38-2
Network . . . . .	38-3
Cabling . . . . .	38-3
Communications Parameters . . . . .	38-4
Thumbwheel Switches . . . . .	38-5
DIP Switches . . . . .	38-5
Square D Word and Bit References . . . . .	38-8
Access Permitted by Maintenance Template . . . . .	38-10
<b>Chapter 39</b>	
<b>Texas Instruments PLCs . . . . .</b>	<b>39-1</b>
Memory . . . . .	39-2
Possible Configurations . . . . .	39-5
Direct . . . . .	39-5
Direct with DCPM . . . . .	39-5
Direct with DCU . . . . .	39-5
Cabling . . . . .	39-6
Communications Parameters . . . . .	39-7
Dual Communication Port Module TI 500 Series . . . . .	39-7
Serial Interface Port TI 435 PLC . . . . .	39-8
Data Communication Module TI 405 Series . . . . .	39-10
Data Communication Unit (DCU) TI 305 Series . . . . .	39-12
Texas Instruments Word and Bit References . . . . .	39-21
Access Permitted by Maintenance Template . . . . .	39-28
<b>Chapter 40</b>	
<b>Westinghouse Numa-Logic PLCs . . . . .</b>	<b>40-1</b>
Memory . . . . .	40-2
Possible Configurations . . . . .	40-3
Direct . . . . .	40-3
Cabling . . . . .	40-3
Communications Parameters . . . . .	40-4
Westinghouse Word and Bit References . . . . .	40-5
Access Permitted by Maintenance Template . . . . .	40-8

<b>Appendix A</b>	
<b>Detailed Specifications</b> .....	<b>A-1</b>
Main Processor .....	A-2
Display .....	A-2
Environment .....	A-2
Power Requirements .....	A-2
Serial Port .....	A-3
Other .....	A-3
<b>Appendix B</b>	
<b>Configuration Creation Checklist</b> .....	<b>B-1</b>
Configuration Creation Checklist .....	B-2
<b>Appendix C</b>	
<b>Installation Guidelines</b> .....	<b>C-1</b>
Overview .....	C-2
Physical Installation Considerations .....	C-2
Environmental Considerations .....	C-4
Wiring Considerations .....	C-5
<b>Appendix D</b>	
<b>Software Menu Hierarchy</b> .....	<b>D-1</b>
Editor Structure Hierarchy .....	D-2
Editor Structure Hierarchy with Key Chapter Cross Reference .....	D-3
<b>Appendix E</b>	
<b>International Font Characters</b> .....	<b>E-1</b>
Font Selection .....	E-2
Font Character Cell Representation .....	E-2
<b>Appendix F</b>	
<b>Worksheets</b> .....	<b>F-1</b>
<b>Appendix G</b>	
<b>Notes for the User of other PanelMate Series Products</b> .....	<b>G-1</b>
Notes for the User of other PanelMate Series Products .....	G-2
Overview .....	G-2



# Chapter 1

## Introduction

---

In this chapter, you will learn:

- How to use this manual
- Who this manual is written for
- Which notational conventions are used

# How to use this Manual

Welcome to the Cutler-Hammer IDT PanelMate Series 1000 Product Manual. The manual contains everything you need to know about PanelMate Series 1000 assembly, installation, operation, maintenance, and configuration.

Your PanelMate unit has eight pages of memory.

As a new user of the PanelMate Series 1000, you will want to get acquainted with how the PanelMate unit works and how it is used before you begin configuration of your own control system. It is recommended that you take time now to read Chapter 2, Overview. Once you have an understanding of what you can expect from the PanelMate unit, you can proceed through the manual, using it as a guide for assembly, configuration, installation, operation, and maintenance. To make the manual more readable, information about the PanelMate unit interaction with specific programmable controllers (PLCs) is segregated into chapters. After you have become accomplished at configuring screens and have placed the PanelMate unit in operation, this manual will become a reference book for regular maintenance, troubleshooting, and repair.

This manual is written for system engineers, plant engineers, plant maintenance personnel, Cutler-Hammer IDT personnel, and any persons who may be involved in configuring screens or installing and maintaining a PanelMate unit. This manual is not written for plant personnel who will be using the PanelMate unit to control factory operations. The task of informing plant operators how to use the PanelMate unit in specific situations is left to those who configured the screens.

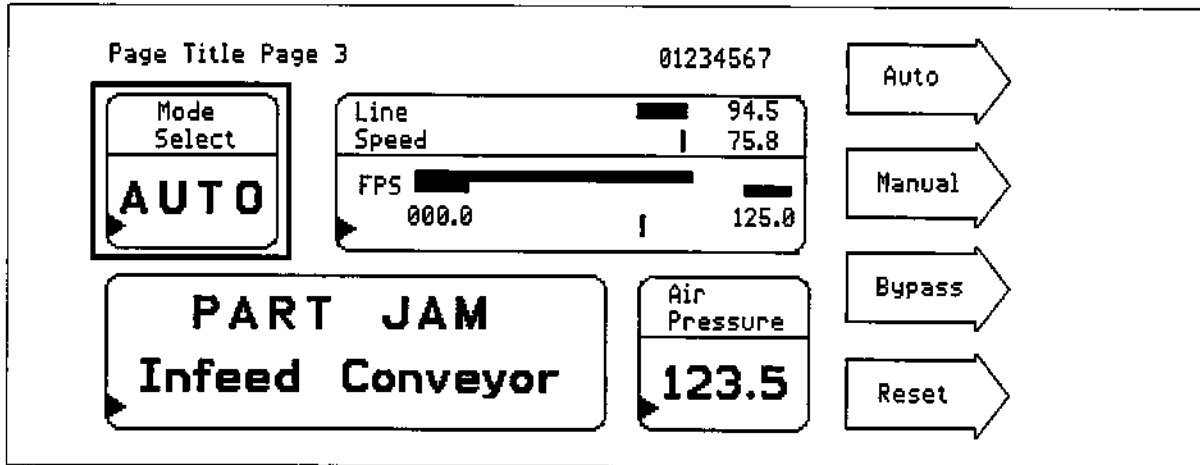


Figure 1-1 Example Page

# Typographical Conventions

---

Certain typographical conventions are used consistently in this manual. They include:

< >	Delineates a specific key on the Configuration Keyboard
<Return>	Refers to the enter or return key on the Configuration Keyboard
Cursor arrow keys	Refers to the up, down, right and left arrow keys located on the numeric keypad of the Configuration Keyboard
[ ]	Delineates a PLC word or bit reference
PLC	Abbreviation for programmable logic controller
VCP	Refers to the Video Control Panel

## Manual Organization

---

This manual is divided into four parts:

Part 1 - Overview & Installation

Part 2 - Configuration Software

Part 3 - Utilities

Part 4 - Communications

In addition, there are six appendices:

Appendix A - Detailed Specifications

Appendix B - Configuration Creation Checklist

Appendix C - Installation Guidelines

Appendix D - Software Menu Hierarchy

Appendix E - International Font Characters

Appendix F - Worksheets

The manual is written as an instruction manual for beginning users and as a reference manual for more experienced users. Each chapter leads with learning objectives that present the main topics of the chapter. By scanning the learning objectives, a beginner will get a preview of the chapter, while an experienced user will be able to quickly determine if the chapter contains the information that is sought.



# Chapter 2

## Overview

---

In this chapter, you will learn:

- The benefits of the PanelMate unit
- The words we use to describe the PanelMate unit
- How easy it is to configure screens
- How the PanelMate unit works

# Benefits

---

The Cutler-Hammer IDT PanelMate unit provides an economical and flexible alternative to hardwired operator control panels. Using a single serial connection to a PLC, the PanelMate unit can replace individual control devices such as pushbuttons, selector switches, indicating lights, thumbwheels, analog meters, message display units, and digital readouts, as well as all of the associated wiring and PLC I/O modules. The Cutler-Hammer IDT PanelMate unit is capable of replacing over 400 hardwired devices, yet it is economical to use even if only a handful of points are being controlled or monitored. The benefits are even greater if subsequent changes are made to the operator's panel.

In addition to replacing conventional panel-mounted controls, operator message units, and controller faceplates, the PanelMate unit also works as an alarm annunciator and logger. Critical PLC control operations can be monitored constantly and abnormal conditions reported on the screen. The PanelMate unit can also replace TCAM (timer/counter access module) devices, DTAM (data table access module) devices, and RAP (register access panel) devices that are typically used during setup and troubleshooting.

The Cutler-Hammer IDT PanelMate unit offers advantages over hardwired devices similar to the advantages provided by PLCs over conventional relay control systems. You have the flexibility of being able to quickly construct or alter operator controls without coordinating the purchase and fabrication of a panel that contains a variety of devices from different vendors. Control panel wiring is eliminated and the cost and lead time of developing an operator interface is reduced. Adding a control function later is simple and costs virtually nothing. Solid-state technology provides inherent reliability advantages over mechanical control devices. Additionally, no special training or computer programming skills are required for screen configuration or online use because the PanelMate unit uses the same kind of logic and terminology as conventional control panels and PLCs.

The key to easy system integration is the PanelMate DOS-based configuration software with a family of editors. These easy-to-use integrated editors smoothly guide you through an uncomplicated fill-in-the-blank process. No special training is required because the PanelMate unit configuration editors guide you in arranging pre-stored templates on the page and defining each template's individual operating characteristics.

After configuration, the configuration software's self-documenting feature provides hardcopies of the current configuration for your records. This capability makes generating complete documentation of the control system quick and easy. The DOS-based package can be used for backup or easy transfer of the configured pages to other PanelMate units.

Besides eliminating PLC I/O to the control panel, the microprocessor-based PanelMate unit can also relieve the PLC of the burden of comparing values against alarm limits, thus giving you more room in the PLC for control logic. This means you can reduce the load on the PLC for other application requirements at no increase in price. Savings are also achieved by reducing the PLC programming that is required for the control system.

The PanelMate unit also improves operator performance compared to conventional control panels. The PanelMate unit reduces the number of sensory inputs that the operator is subjected to at any one time. It can also be used to set priorities for the operator's attention. Just four multi-function control buttons and a sealed, quick response keypad replace hundreds of buttons and switches found in typical control panels. The use of multi-functional control buttons improve operator performance by providing only appropriate input options.

Once in the Run Mode, the PanelMate unit displays control information simply, clearly and quickly for instantaneous operator action. Since the PanelMate unit can be used with all major brands of PLCs, it can become your plant's standard man/machine interface, thereby reducing your training costs and improving operator performance.

In addition to its serial communication abilities, the PanelMate unit is available with an optional AcceleratI/On interface. This feature allows direct connection to Allen-Bradley Data Highway, Data Highway Plus, or Remote I/O networks without the need for a separate interface module. AcceleratI/On provides an increase in PLC-access speed while reducing overall equipment costs.

The PanelMate unit benefits include:

- Reduced cost and lead time of engineering configuration
- Eliminates extensive I/O wiring
- Flexibility to easily change control function
- Control operations can be monitored constantly and can be easily adjusted
- Reduced load on the PLC, along with reduced PLC programming
- Reporting of alarm conditions
- Exceptionally easy-to-use configuration editors
- Easy connection to all major brands of PLCs

## Product Description

---

The Cutler-Hammer IDT PanelMate video control panel is a compact, rugged operator interface device for use with PLCs. The PanelMate Series 1000 uses a 5-inch LCD (Liquid Crystal Display) and a unique set of graphic templates to display the status of PLC variables in an easy-to-read fashion. Operators can also control or adjust PLC operations directly from the PanelMate unit using the built-in membrane keys. The Cutler-Hammer IDT PanelMate unit is designed for easy mounting in a variety of industrial enclosures, including consoles, standard racks, and floor or wall-mounted panels. The entire front bezel of all the units is gasketed and completely sealed against dust, dirt, oil, and moisture, making the PanelMate unit ideal for use in harsh NEMA 4 or NEMA 12 applications. Stainless steel options are also available and are designed for NEMA 4X requirements.

The PanelMate unit's DOS-based configuration software is structured with a few principal sections accessible directly from the Main Menu. Additional built-in features, functions, and editors are available within each software section. The product documentation and on-screen status messages and help pages assist users to rapidly enter and exit the sections needed for display creation and online operation.

## PanelMate Online System

---

The Cutler-Hammer IDT PanelMate unit has single piece construction. The front panel contains the TouchPanel and the Control Panel.

The PanelMate unit has eight pages of memory.

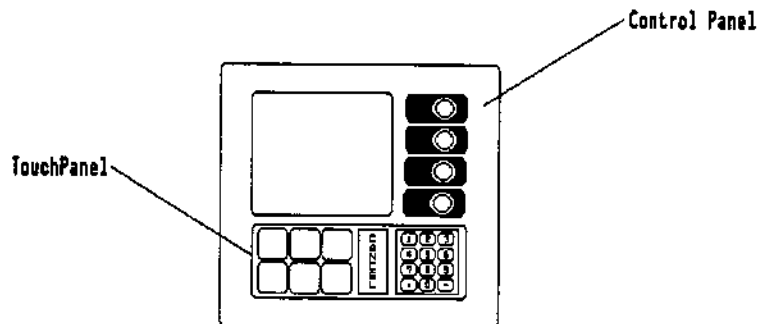


Figure 2-1 PanelMate Series 1000 Front View

## **DOS-based Configuration Software Package**

The Cutler-Hammer IDT PanelMate unit makes designing your PLC-based control systems easy. The PanelMate unit uses templates to present information to the online operator, thus providing a proven, standard method of presentation.

The DOS-based configuration software consists of menus, editors, option windows and spreadsheets. The spreadsheets and editors are used to configure the pages that make up the online system.

The PanelMate Configuration Package consists of the following major menus, editors and spreadsheets:

- Main Menu
  - Configuration Editor
    - Directory Editor
    - Page Editor
    - Template Editors
    - Message Library Editor
    - System Parameters Editor
    - PLC Name and Port Table Editor
    - System Online Labels Editor
    - International Font Selection
    - Print Documentation

The complete Editor Structure Hierarchy is shown in Appendix D.

Refer to Chapter 9 for requirements for your personal computer to run the DOS-based configuration software.

## **Special Features of the Configuration Mode Package**

The PanelMate editors are designed to be easy and straightforward to use. All editors have several features in common, so that no additional learning is required to move from editor to editor. These features are described below in alphabetical order.

## Cursors

The PanelMate configuration software uses four cursors when operating on a color personal computer. Only one cursor will be visible on the screen at any one time. All cursors are controlled by the arrow keys. The four cursors are:

Cell Cursor	a black border surrounding a blank cell or template when it is selected
Field Cursor	a green bar that highlights a cyan field when it is selected
Character Cursor	a small white block that appears in the selected character field when the EDIT mode is selected
Insert Mode Cursor	a half-size version of the character cursor that appears in the selected alphanumeric field when <Ins> is pressed

## Cursor Moves

All cursors can be moved using the arrow keys.

**Note** NUMLOCK must be OFF

In the Page Editor, the cell cursor moves one cell at a time, regardless of the size of the template it is marking, e.g., two cursor moves are required to move across a double-wide Indicator Template.

## Error Messages

When you attempt to do something that is not allowed, an error message will be printed at the bottom of the screen and an error tone will be generated. To cancel the error message, simply continue with the correct keystroke.

## Field Colors

In the Directory Editor and all template editors, an entry field will display the following colors:

cyan	a closed field
green	the field that is currently selected for viewing or editing
blue	a selected field that can be edited; i.e., a green field will become blue when <Return> is pressed.

## Function Keys

In the editor screens, a menu at the top of the screen shows the functions of the <F1> through <F10> keys. An example is shown below.

F1=TEMPLATE	F2=	F3=MESSAGE	F4=	F5=
F6=	F7=	F8=	F9=SAVE	F10=EXIT

Figure 2-2 Page Editor Main Menu

The <Return> key is always used as a toggle to the editing mode. Press <Return> to open the field (the selected field will change from green to blue), make changes, additions, insertions and deletions as necessary, and then press <Return> to close the field. You must close before you select another field.

The <Esc> key is used to close a field and revert to the previous value.

The <F10> is always used to exit from the editing screen that is currently displayed. Pay attention to prompting messages, as they may remind you about saving changes before exiting.

<Ctrl> <m> is used to insert a carriage return within a text string.

<Alt> <F1> is used to call a help page anytime "HELP" is displayed in the upper right corner of the screen.

## Template Mode

The Cutler-Hammer IDT PanelMate unit uses pre-defined functional templates to represent indicator lights, digital readouts, analog (level) meters and message display panels. The six primary template types are called the Indicator, Readout, Bar, Display, Table, and Maintenance templates. The Maintenance template can be used for setup and troubleshooting.

The screen is divided into 6 template cells. A template is positioned and defined with the use of function keys, arrow keys and screen prompts.

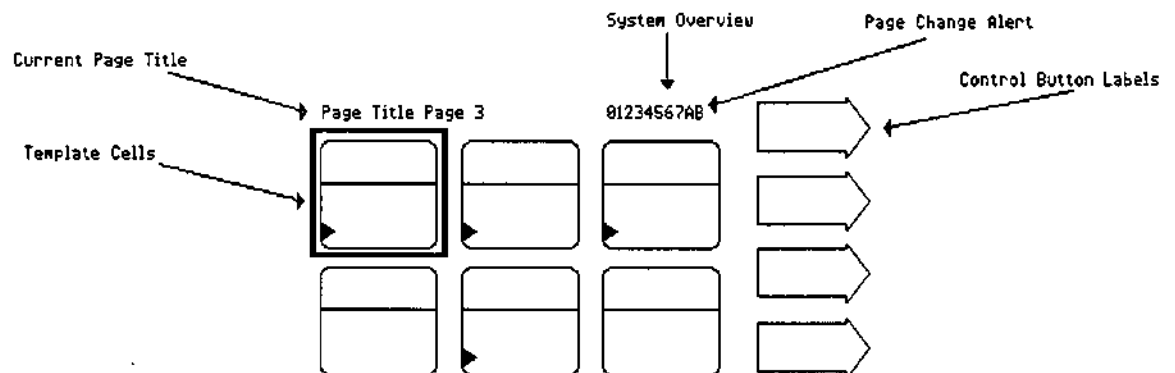


Figure 2-3 PanelMate Series 1000 Page Layout

The type of template chosen determines the way in which PLC data will be displayed and the information you need to provide to define its operation. The definition data will usually include the device name for the template (e.g., "BACKWASH PUMP 1" or "KILN 27 TEMP"), the PLC locations to be monitored, the associated visual attributes and status messages to be used to represent different conditions, and any high and low alarm limits to be considered. Each template also allows you to define control functions which will be available to the operator, such as the ability to start a motor or adjust a setpoint value.

The PanelMate unit will allow up to 8 pages to be created with 6 templates per page. Any combination of template types may be grouped on a single page, allowing you to tailor the layout of the controls to the needs of your particular application.

A single template may be used to represent a number of hardwired devices. As a simple example, an Indicator template with control functions might replace three indicator lights (Running, Stopped, Tripped) and two pushbuttons (Start, Stop).

When defining the operation of a template, you can indicate that certain conditions are to be recognized as abnormal or alarm conditions. In the above example, the "Tripped" condition is abnormal. The Cutler-Hammer IDT PanelMate unit watches for these conditions, even when the page containing that template is not being displayed. If that condition occurs, an overview field (built into every screen) indicates graphically the pages which contain alarm conditions.

## **Run Mode**

---

Once a display configuration is completed in the configuration software Package, it can be downloaded to the online system. The Cutler-Hammer IDT PanelMate unit is ready to be connected to a PLC. The PanelMate unit can be easily used with all major brands of PLCs and intelligent control devices. A single serial cable is required to connect the PanelMate unit with a programmable controller.

In addition to its serial communication abilities, the PanelMate unit supports the optional Accelerati/On interface. With this feature, the PanelMate unit can communicate to an Allen-Bradley Data Highway, Data Highway Plus, or Remote I/O network without an Allen-Bradley interface module.

On power-up, the PanelMate unit performs system diagnostics. If a failure should occur, an indication of the problem will be displayed. After power-up diagnostics are completed, the system display configuration is loaded into working memory.

The initial page will be drawn and the control button labels will appear. The control buttons and TouchPanel may be used to call another page.

Any template that displays a small arrow in the lower left-hand corner of the template is defined for control by the operator. Before any control change can be made to a particular device, that template must be selected. To select a particular template, press the area of the TouchPanel that corresponds to the location of the template on the screen. If the template is defined for control button input, the corresponding control button labels will appear when it is selected. The operator can then press the appropriate control button (to start or stop a motor, for example), or press the large cancel key to disarm the control buttons. All control buttons provide momentary operation control. Therefore, the designated PLC bit will be set to ON or 1 when the button is depressed and will reset to OFF or 0 when the button is released.

If the template is defined for numeric keypad input, the control button labels will prompt you to enter the new value. All numeric operator inputs require at least two keystrokes. This prevents any accidental entries that could occur by pressing the wrong key.

All alarm conditions designated in the PanelMate unit editors are constantly monitored. When an alarm condition occurs, the page which contains the alarm will be identified in the system overview field.

The PanelMate unit will request updates from the PLC for data on the current display page and for all alarm points.

## System Overview Field

The System Overview field is located on the top line after the page title. The field provides the status of the pages. A page may be blank, configured or in alarm and is designated as follows:

Blank	This page has no information on it. The page number will not appear.
Configured	This page is configured and all devices are operating normally. The page number will appear in normal video.
In Alarm	One or more devices on this page are in an alarm condition. The page number will blink.

The PanelMate unit has 8 pages of memory and will show the status of pages 0 through 7 consecutively. Refer to figure 2-4.

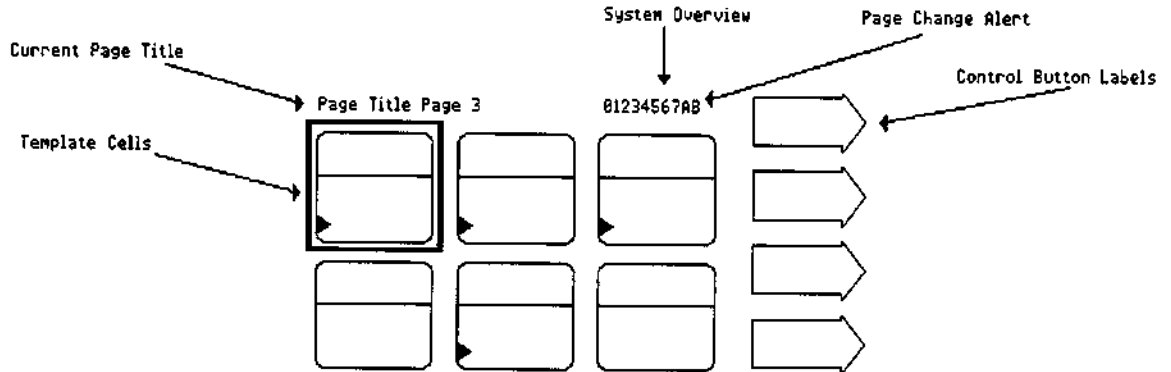


Figure 2-4 PanelMate Series 1000 Page Layout

The Password Status information is displayed to the right of the page information. The alert for a pending page change is displayed next to the password status.

## Hardware Description

The PanelMate Series 1000 features a 5-inch backlit liquid crystal display (LCD). The 320 x 240 resolution flat panel displays monochrome images (normal, reverse video, and blinking). The screen will display VGA quality text.

## Editing Standards

---

The editors of the configuration software package have consistent methods for entering or changing information.

### Data Fields

---

In any configuration software editor screen, areas which can receive numbers, addresses, or other data are called fields. On a color personal computer, these are green rectangular areas which may or may not already contain data. One of the fields on a page or menu will be highlighted green. You may move among fields by pressing the arrow keys, thus changing which field is highlighted. To open a field for data entry, press the arrow keys to highlight the desired item and then press <Return>. A field will turn blue while open (darker than cyan). After entering data, press <Return> again to close the field. The <Esc> key may be pressed during data entry to cancel any changes and revert to the old values and close the field.

When a field which allows text entry is open, one character in the field will be flashing. This is the location of the character cursor. The cursor is the place where characters will be entered or changed. The left and right arrow keys will move the cursor within the field.

Some numeric fields will allow you to increase or decrease their value with the up and down arrow keys while open. Some fields will present a menu of options for you to choose from (see Option Window below).

### Option Window

---

When changing a data field or making a choice that has a small number of defined alternatives, you will see an option window. This menu is shown below.

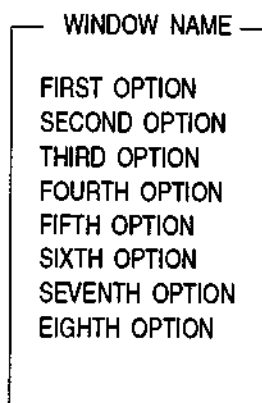


Figure 2-5 Option Window

When the menu appears, the currently selected option is highlighted in a different color from the other lines. The arrow keys may be pressed to highlight any option in the list. When you have highlighted the desired option, the <Return> key is pressed to make the selection.

The window will display all potential options. The cursor will move over any option that is not currently accessible due to the interaction of other choices made during configuration.

The following rules apply when highlighting an option:

- The up, down, left, and right keys move the highlight in their indicated directions.
- The <Return> key will select the highlighted option.
- The <Esc> key will exit without selecting an option and revert to its old value.

Any other keys will cause the error message "WRONG KEY. TRY AGAIN." to be displayed.

## **Help Pages**

---

The various editors of the Configuration Utility provide help pages to aid application development. You may press <Alt> <F1> whenever the word "HELP" appears in the upper-right corner of an editor screen.

## **Fonts**

---

The PanelMate unit character set contains four fonts: standard, double high, quad, and graphic. Each font may contain up to 128 characters. A character cell is 8 pixels wide by 16 pixels high. Characters in the normal font are one character cell in size. Double high characters are two character cells high and one wide. Quad characters are two cells wide by two high. The Graphic font is a system font used to draw the rounded corners on templates and to display bar graphs. The Double-High, Quad, and Graphic fonts cannot be changed by the user.

Normal font includes the standard alphanumeric character plus some blank characters. These blanks may be modified to add letters for international languages if the user desires. The Double High and Quad fonts each have a-z, A-Z, 0-9, the period, and the minus sign.



# Chapter 3

## How to Successfully Develop Your Application

---

In this chapter, you will learn:

- The Basic Steps for Creating a Successful Application
- How to Plan Screen Layouts
- How to Enhance Operator Performance
- How to Gather Background Information
- How to Improve Operator Performance

## **Basic Steps for Creating a Successful Application**

---

Creating a successful application requires upfront planning. Include the PanelMate unit in the planning process at the same time the decision on the PLC is being made. Remember you are developing a control SYSTEM. All the components must interface together to create the system.

The basic steps to project success are:

- Defining the Scope of the Project
- Defining the Page Layout
- Enhancing Operator Performance
- Gathering Information for Configuration

## **Defining the Scope of the Project**

---

The process begins by first defining the scope of the project. It is important to work with the operators and supervisors to define what decisions they make, what actions they take and the information that they need to make their decisions. Operators use the system. Include operator participation in the upfront planning and testing of the implementation. If you allow the operators to become a part of the team and incorporate their feedback in developing the control system, you will have satisfied operators and a successful project.

Note the use of the term information and not data. Information will allow decisions to be made more quickly than just providing raw data.

In order to maximize the performance of any operator interface connected to a PLC over a network or highway, it is necessary to keep network traffic to a minimum. You can greatly improve the performance of the PanelMate unit and the network by grouping your PLC registers consecutively in PLC memory.

## Defining the Page Layout

---

Once the scope of the project and the amount of network traffic is minimized, a Strategy for Page Implementation must be resolved. This includes defining how many pages will be used and the page layout for each individual page. Plan the implementation strategy BEFORE you begin to configure your pages.

Make your pages consistent. Group control functions on pages so that operations that are performed together are grouped together. Also, do not hesitate to make individual pages look dissimilar so the operator can easily distinguish pages without having to read the page title.

Simplify wherever possible. Eliminate confusion and strive for rapid visual comprehension. Do not overcrowd the screen. Provide summary information not raw data. Provide information by exception and make exceptions obvious.

Use bar graphs to quickly communicate approximate values relative to full scale. Bars placed side by side representing different variables can rapidly express comparative values (higher than, lower than). Numbers take longer to read and interpret than bar graphs. Use numbers when exact values are required. Displays with both bar graphs and numbers can nicely complement each other.

An operator generally does not need a detailed photographic representation of a machine or process. Typically, simple representation is all that is important. An operator typically prefers good diagnostic messages and machine/process restart instructions over a pretty picture.

Use activity to show operation by changing visual attributes. Remember to provide information by exception. If a display area always blinks, it will not be perceived as important, and may even appear as a distraction.

Raw data must be transformed into useful information before an operator can perceive and identify an event on the screen.

In addition to text description visual attributes such as normal, reverse video, and blink can offer an important means to communicate to operators. These attributes should be used as a highlight; the display should be understandable before they are added to enhance perception. Create standards and use them. Blink is an attention-getting visual device. It should be reserved for drawing the operator's attention during other-than-normal operation or when operator action (such as data entry) is required.

# Enhancing Operator Performance

---

Selection of Attributes	Be consistent. Use the same intensities to designate the same conditions throughout the system.
Character Sizes	Always use the largest size characters that will fit in the template.
Device Names	Use upper and lower case characters; they are easier to read than all upper case. Left-justify the device name to make placement consistent for the operator.
Control Button Labels	Use upper and lower case characters; they are easier to read than all upper case. Be very descriptive so that it is easy to determine which template's control button labels are on the screen. For example, for a start button, use the label "Start Motor 2" instead of "Start".
Control Button Positions	<p>Group buttons together near the middle of the screen. The only exception to this would be when you wish to purposefully separate a critical function from other control functions.</p> <p>Templates that require the same types of operator control (such as stop/start) should have their control buttons consistently placed in the same positions (e.g., stop is always the second button and start is always the third button).</p>
Page Layouts	Group controls on pages so that operations that are performed together are grouped together. Also, make pages look dissimilar so the operator can easily distinguish page changes without referring to the page number.
Audible Feedback	Feedback for operator input greatly improves operator performance.
Mounting Position	Mount the PanelMate unit at eye level.
Display Adjustments	Reduce potential eyestrain by adjusting the monitor's contrast for the ambient lighting of the online PanelMate unit.
Automatic Cancel	Use this feature to avoid accidentally leaving the control buttons armed for an extended length of time.
Leave PanelMate Running	There is no reason to power down the PanelMate unit during normal operation. The PanelMate unit is designed to be used as part of your control system, and is expected to perform as reliably and consistently as your PLCs or control panel devices.

## **Gathering Information for Configuration**

---

The final task before sitting down with the configuration software package is to gather all the background information you will need. Chapters 13 through 21 describe the editors used in the PanelMate unit and each chapter will have a worksheet to support the "Gathering Information for Configuration" section. Appendix F contains copies of all the worksheets which may be copied for repeated use.



# Chapter 4

## Hardware Checkout Overview

---

In this chapter, you will learn:

- How to set-up the PanelMate Series 1000 for checkout
- How to check system health

# Unpacking

---

Report any damage to the carrier who delivered the equipment and immediately call the Cutler-Hammer IDT Customer Service Department at (614) 882-3282 (the Interstate Commerce Commission has a time limit on reporting concealed damage). Check packing cartons for all items shown on the packing list.

Carefully remove all equipment from the packing cartons and inspect all parts for damage in shipment. Keep the cartons and packing materials for future shipment.

Please check to be certain that all items are present:

## PanelMate Series 1000

- \_\_\_\_\_ 1 PanelMate Series 1000 unit
- \_\_\_\_\_ 1 Hardware Manual
- \_\_\_\_\_ 1 Shipping kit (plastic bag) containing:
  - \_\_\_\_\_ 1 Packet of mounting nuts and washers
    - \_\_\_\_\_ 10 #6 nuts, 10 #6 washers
  - \_\_\_\_\_ 1 Packet with a three-terminal connector
  - \_\_\_\_\_ 1 Cutout/torque drawing

If you ordered a Support Kit as an accessory, it will be packaged separately:

- \_\_\_\_\_ 1 Transfer Utility with manual
- \_\_\_\_\_ 1 Packet of mounting nuts and washers containing:
  - \_\_\_\_\_ 10 #6 nuts, 10 #6 washers
  - \_\_\_\_\_ 1 Packet with a three-terminal connector
  - \_\_\_\_\_ 1 Cutout/torque drawing

# Check System Health

You may wish to test your unit before you install it in your industrial enclosure. This section outlines the steps required to set-up the PanelMate unit on a work surface for check-out before installation. You will be performing the following procedure:

1. Connect to 24V DC power. This will immediately start the unit.
2. View the demonstration screens.
3. Execute the system diagnostics:
  - Perform Keypad Test
  - Perform Display Tests
4. Enter the Run Mode.

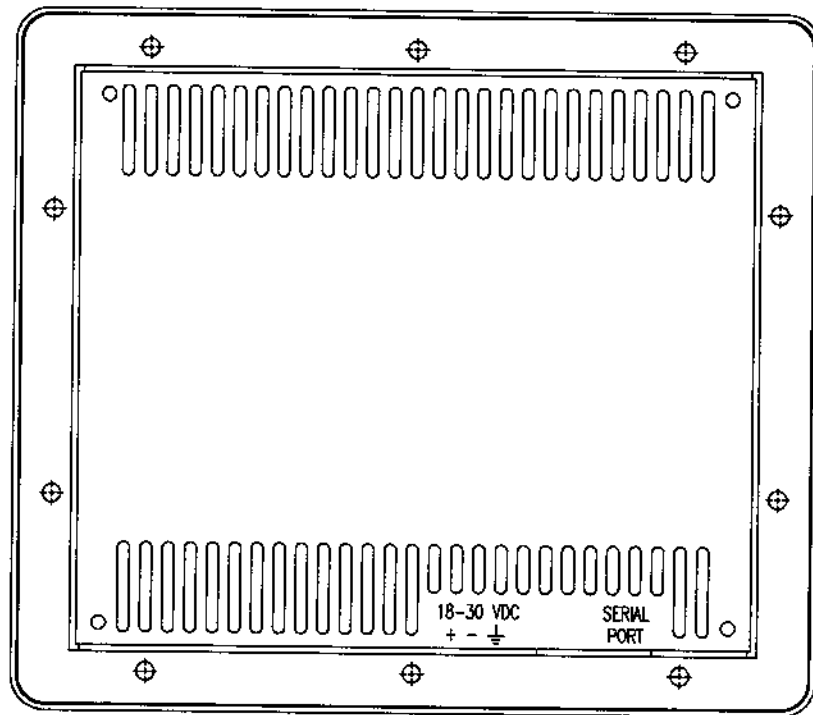


Figure 4-1 PanelMate Series 1000 Rear View

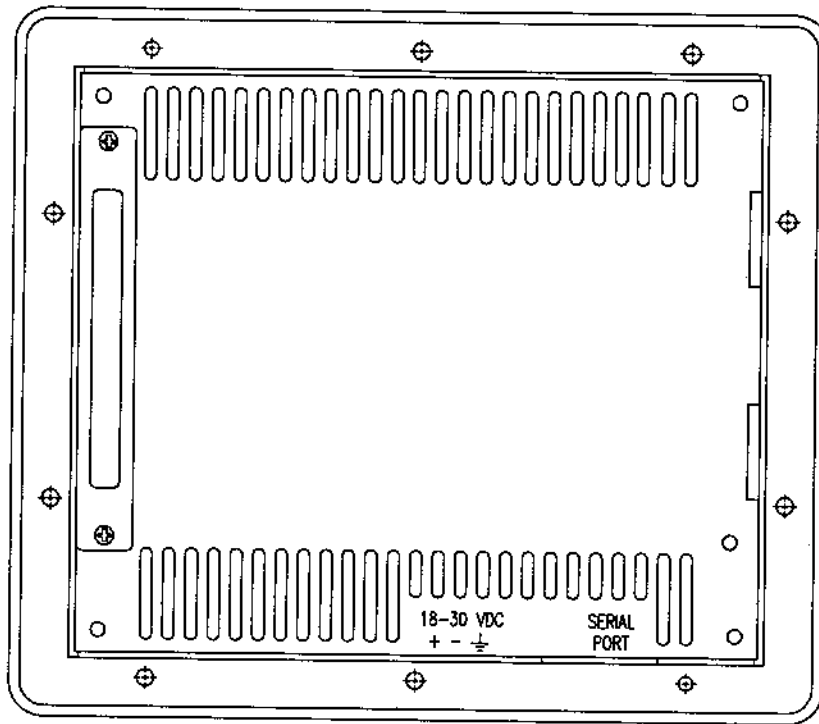


Figure 4-2 PanelMate Series 1000 with an Accelerat/On Connection Rear View

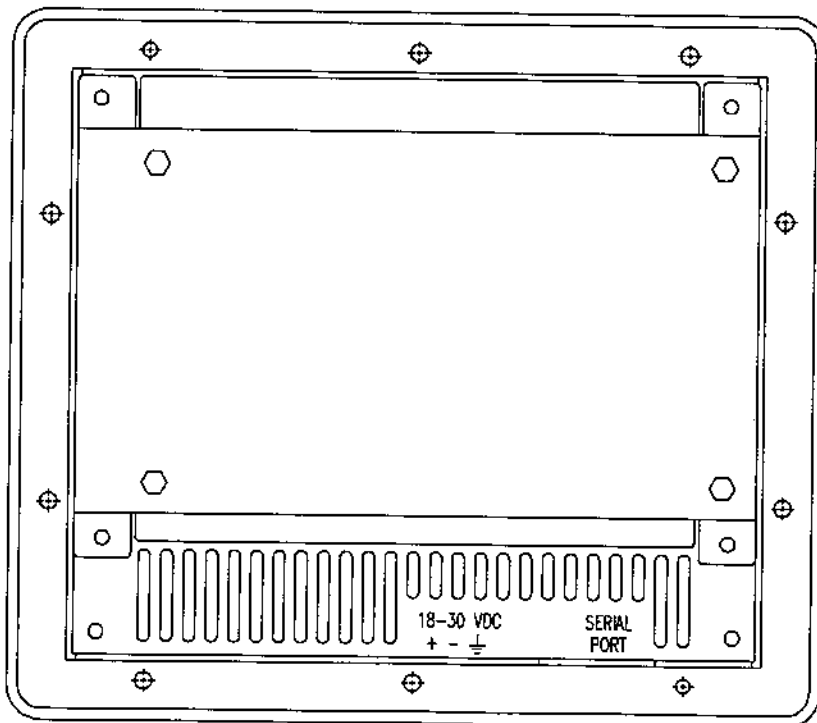


Figure 4-3 PanelMate Series 1000 with Accelerat/On Rear View

## Connect DC Power

---

The DC power connector receptacle is located on the bottom of the PanelMate unit. The unit operates at 24V DC. The removable connector is shipped in a plastic bag. Connect your DC power with user-supplied wiring.

Refer to Appendix A, Detailed Specifications, for more information about power requirements.

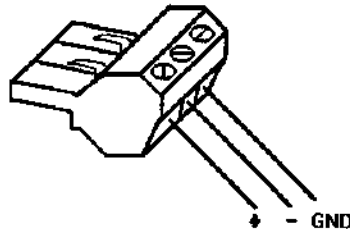


Figure 4-4 Three-Position DC Power Connector

**Note** It is recommended that noise and surge protectors be used when the PanelMate Series 1000 is installed in areas where the power quality is poor.

## Power Up the Unit

---

Apply power to the unit. The PanelMate unit performs approximately 10-20 seconds of internal diagnostic checks. The screen will first display a listing of the diagnostic checks as it executes them. If there is a failure, see Chapter 8, Troubleshooting Guide for the PanelMate System, for assistance.

After the unit completes the diagnostics, it will run the demonstration program.

## Demonstration Program

---

The PanelMate Series 1000 has a self-contained demonstration program which simulates the template functionality as if the unit is connected to a PLC. You may examine the screen to review the product features.

The demonstration software contains a software controlled contrast adjustment. To adjust the contrast, depress the <Cancel> button and select the control button labeled "Contrast". Use the control buttons labeled "Lighter" and "Darker" to adjust the display contrast. To save the new setting, depress the control button labeled "Save Setting". To revert to the previous contrast value, press the <Cancel> key. The PanelMate unit will return to the last saved contrast level after power is cycled to the unit.

To execute the system self-tests, proceed to the next section.

## **Execute the System Diagnostics**

---

To execute the system diagnostics, remove power from the unit. Then re-apply power and immediately press and hold the <Cancel> key on the front of the unit until the system diagnostic screen is erased. Once the diagnostics are completed, the system will be in the Offline Mode. The screen will display four choices. Select a template and press the control button labeled "Execute".

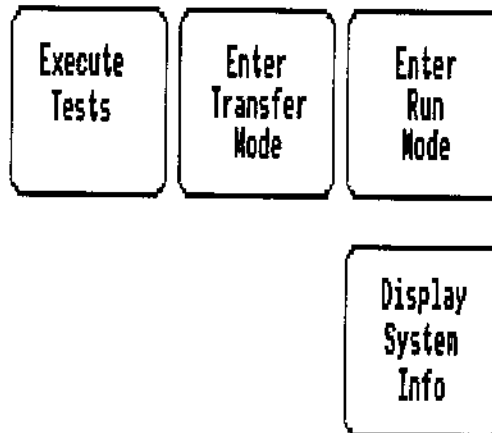


Figure 4-5 Offline Mode Menu

## **Execute Tests**

---

Select the template labeled "Execute Tests" with the TouchPanel located below the display and then depress the control button labeled "Execute". A new page of choices will appear. One can test the serial port, keypad, or display by selecting the appropriate template and then depressing the control button labeled "Execute".

### **Perform Serial Port Test**

This test is only run if a problem is suspected. This test actually checks the serial port hardware and requires two special loopback test plugs that the user must supply for proper operation. To test the RS232 driver, the D-shell loopback plug must jumper pin 2 to 3. To test the RS422 driver, the D-shell loopback plug must jumper pin 1 to 4 and also pin 6 to 9.

To run the test, select Serial Port Test and press the control button labeled "Execute". Place the RS232 loopback plug on the serial port and press the top control button. Follow the instructions on the screen and note the test results. Follow the instructions using the RS422 loopback plug. Press the <Cancel> key to exit the test.

### **Perform Keypad Test**

Select Keypad Test and press the control button labeled "Execute". As a key is pressed, it will be identified on the page display. Use this test to verify keyboard operation. Test the <Cancel> key last as it will exit the test mode.

## Perform Display Tests

Select Display Test and press the control button labeled "Execute". The new page will display an alternating checkerboard pattern that will enable you to verify that every pixel is functional. To leave the test, press <Cancel>.

## Perform Watch Dog Test

Select Watch Dog Test and press the control button labeled "Execute". The new page will display a "Wait for Watch Dog Timeout" message on your screen. If the test is successful, the "Press Cancel Key to Continue" message will appear. Pressing the <Cancel> key will reset the PanelMate unit and return it to the Main Offline Mode Menu.

If the test is not successful, the "Watch Dog Failed, Cycle Power to Reset" message will be displayed. A PanelMate unit that has failed should not be used and should be returned to Cutler-Hammer IDT for repair.

## Test Completion

This completes the internal system diagnostics which are available for you to check-out your unit. To exit the diagnostics page, press the control button labeled "Exit" which will return to the Offline Mode page.

## Enter the Transfer Mode

---

To download and upload files or read system information, the online unit must be in the transfer mode. The PanelMate unit will remain in the ready state until the configuration software has initiated the transfer. Once in the transfer mode, the PLC driver firmware and user configuration files can be downloaded to the PanelMate unit from the Transfer Information selection in the configuration software.

You may change the default communication rate in the PanelMate unit from the configuration software. (The default is 9600 baud.)

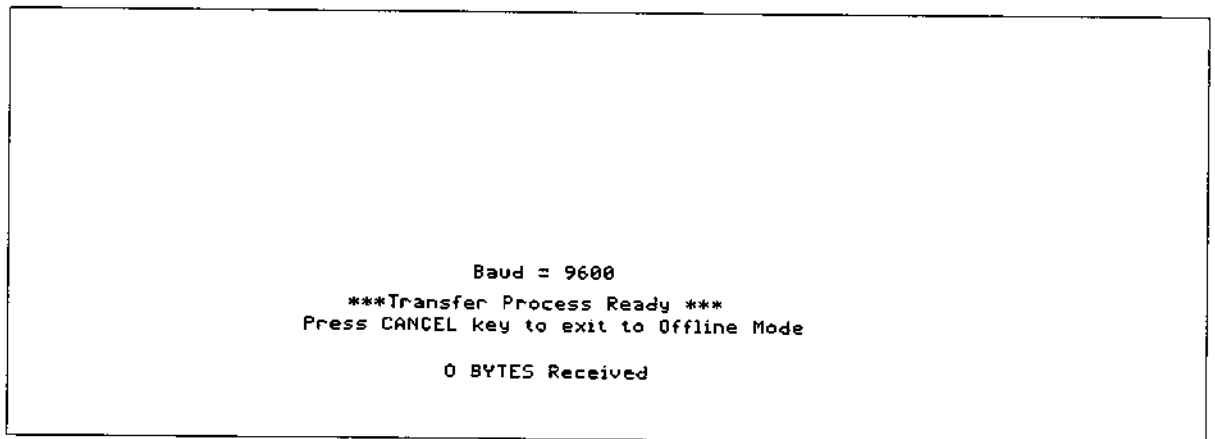


Figure 4-6 Transfer Screen

## Enter Run Mode

---

The Run Mode allows you to run the configuration downloaded to the PanelMate unit communicating to the PLC of your choice.

## Display System Info

---

This selection will display the current configuration information from the PanelMate unit.

```
USER CONFIGURATION
Name:          TEST.PC0
Version:       X.XX
Date/Time:     06/12/93 15:47
Free Bytes:    15632
Used Bytes:    792
Options:       DH-485

INSTALLED DRIVER
Company/ID:    Cutler-Hammer IDT
Product:       PanelMate 1000
Version:       X.XX
Driver:        A-B Serial
Options:       DH-485
```

Figure 4-7 Display System Information

# Chapter 5

## Installation in an Industrial Enclosure

---

In this chapter, you will learn:

- How to install the PanelMate Series 1000 in an industrial enclosure
- How to connect DC power

# Installation in an Industrial Enclosure

---

The PanelMate Series 1000 is designed to be used on the factory floor, mounted in an industrial enclosure. This section contains the information about installing the PanelMate Series 1000 in an enclosure.

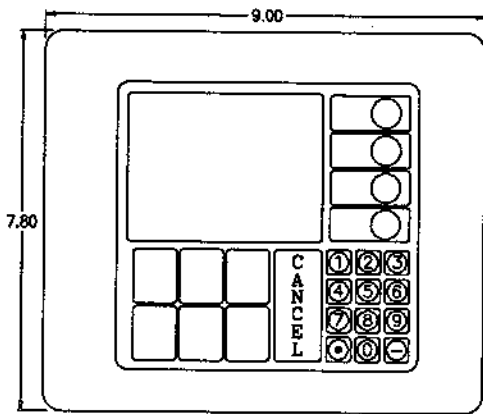
The instructions in this section are based on the assumption that you have already verified unit operation by performing the system health tests defined in Chapter 4.

## PanelMate Series 1000 Enclosure Sizing

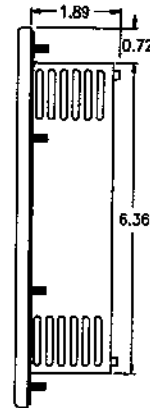
---

Review the PanelMate Series 1000 Outline or the PanelMate Series 1000 with Accelerat/On Outline and Panel Cutout and Torque drawings shown on the following pages. Use this information to determine the enclosure size for your application. There are a number of factors to consider when selecting an enclosure in which to house the PanelMate Series 1000. Although designed to withstand harsh environmental conditions, you must not expose the unit to conditions which are beyond the detailed specifications found in Appendix A. Appendix C contains detailed information taken from enclosure manufacturers which contains guidelines concerning enclosure sizing and temperature specifications.

In order to provide for convection cooling, we recommend a minimum 2-inch clearance above and below the unit and a 1-inch clearance on either side of the unit when installed in an industrial enclosure.



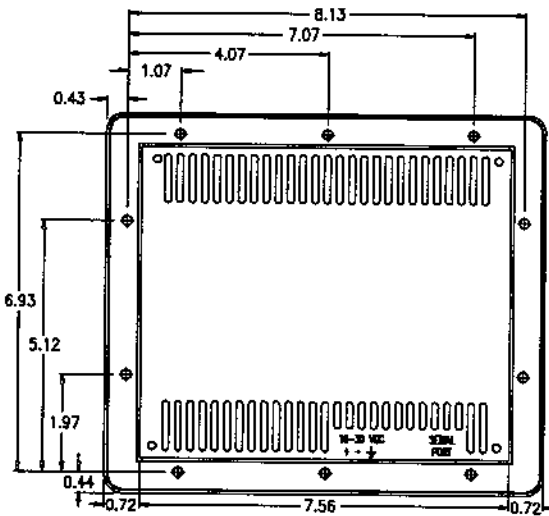
**FRONT VIEW**



**SIDE VIEW**

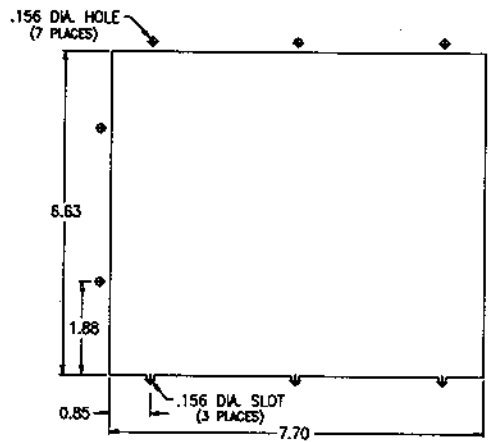
**Unit Weight**  
**4 LBS.**

**TORQUE REQUIREMENTS**  
5 INCH LB FOR #6-32 NUTS



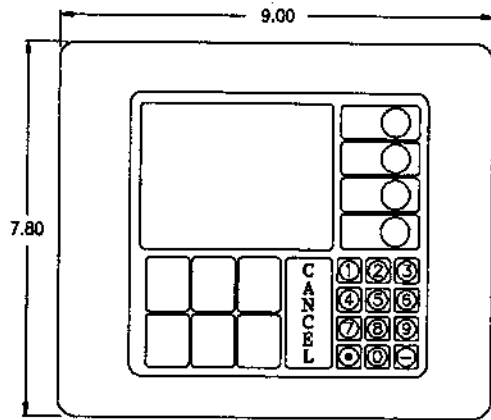
**REAR VIEW**

**RECOMMENDED PANEL CUTOUT**

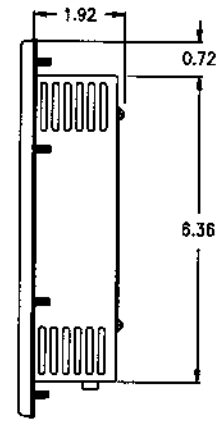


**NOTE:**  
1. ALL DIMENSIONS ARE IN INCHES.  
2. ALLOW CABLE CLEARANCE UNDERNEATH UNIT.

**Figure 5-1 PanelMate Series 1000 Outline**



**FRONT VIEW**

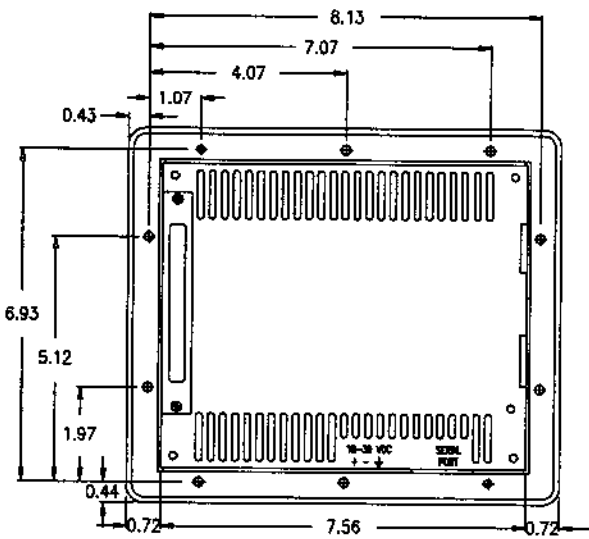


**SIDE VIEW**

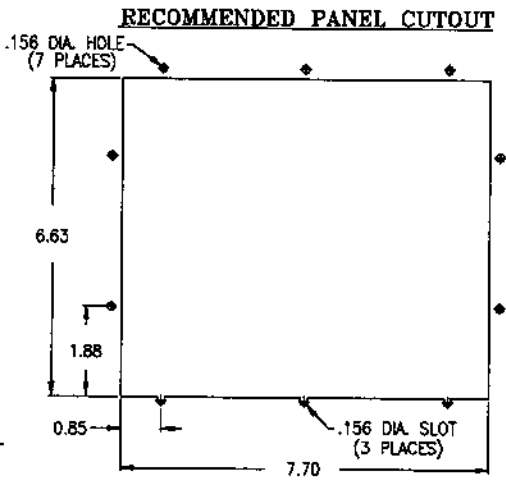
**Unit Weight**  
**4 LBS.**

**TORQUE REQUIREMENTS**  
5 INCH LB FOR #6-32 NUTS

**NOTE:**  
1. ALL DIMENSIONS ARE IN INCHES.  
2. ALLOW CABLE CLEARANCE UNDERNEATH UNIT.

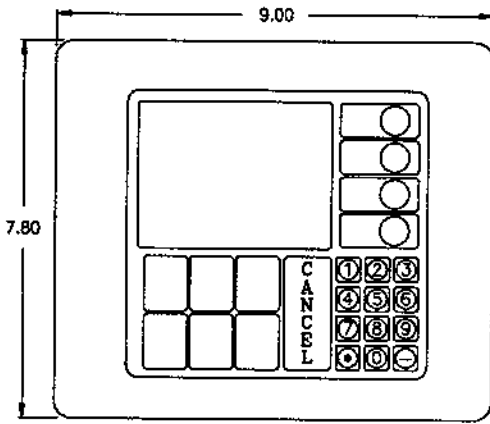


**REAR VIEW**

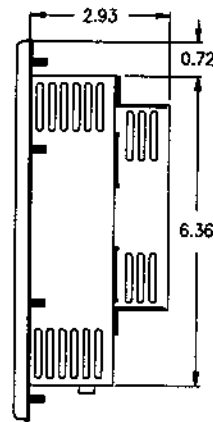


**RECOMMENDED PANEL CUTOUT**

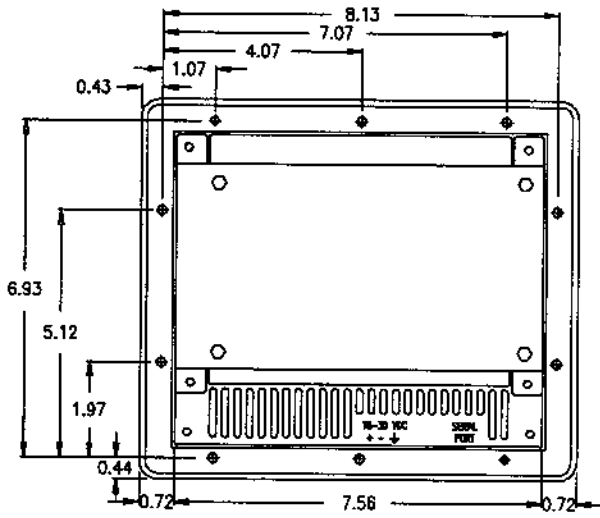
**Figure 5-2 PanelMate Series 1000 with an Accelerat/On Connection Outline**



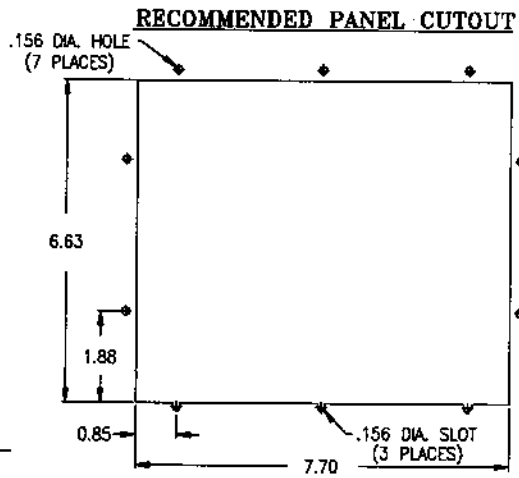
**FRONT VIEW**



**SIDE VIEW**



**REAR VIEW**



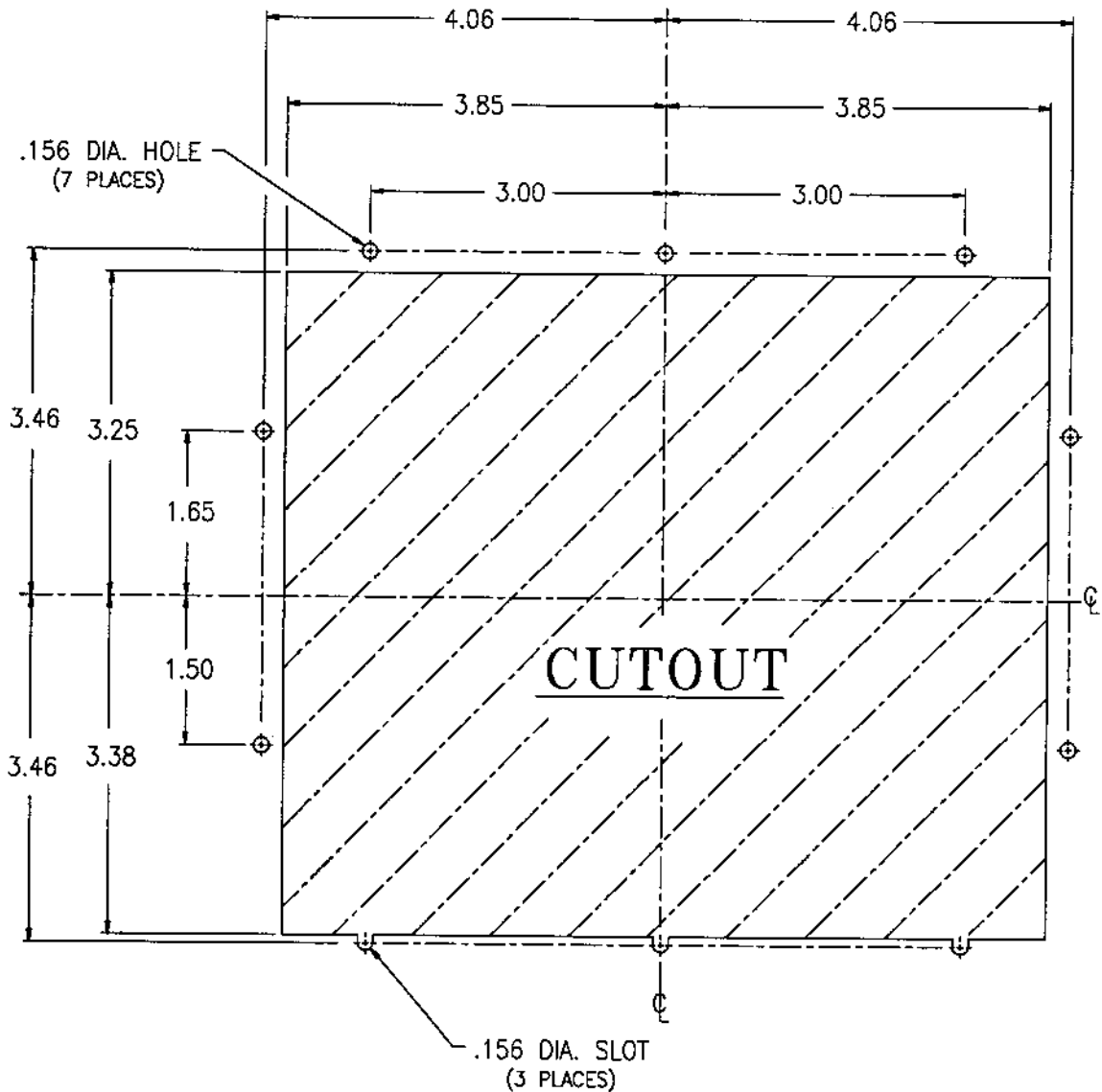
**RECOMMENDED PANEL CUTOUT**

**Unit Weight**  
**5 LBS.**

**TORQUE REQUIREMENTS**  
5 INCH LB FOR #6-32 NUTS

**NOTE:**  
1. ALL DIMENSIONS ARE IN INCHES.  
2. ALLOW CABLE CLEARANCE UNDERNEATH UNIT.

**Figure 5-3 PanelMate Series 1000 with Accelerati/On Outline**

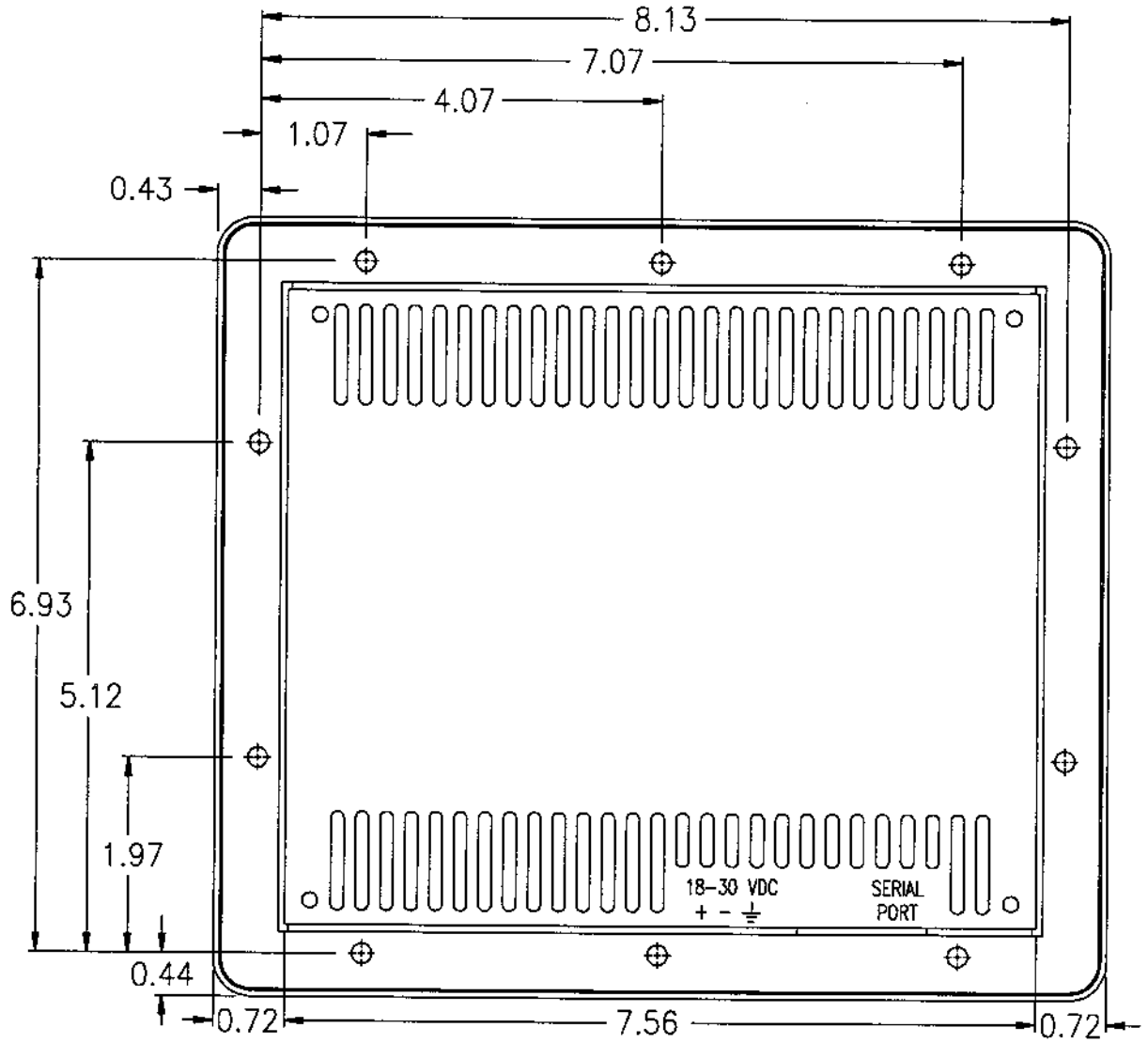


CAUTION: Care should be exercised when tightening the nuts. The fasteners must be tightened enough to obtain a proper seal, but not tightened to the point where the threads are stripped from the welded steel studs.

5 INCH-POUNDS FOR #6-32 NUTS

Note: All units are in inches.

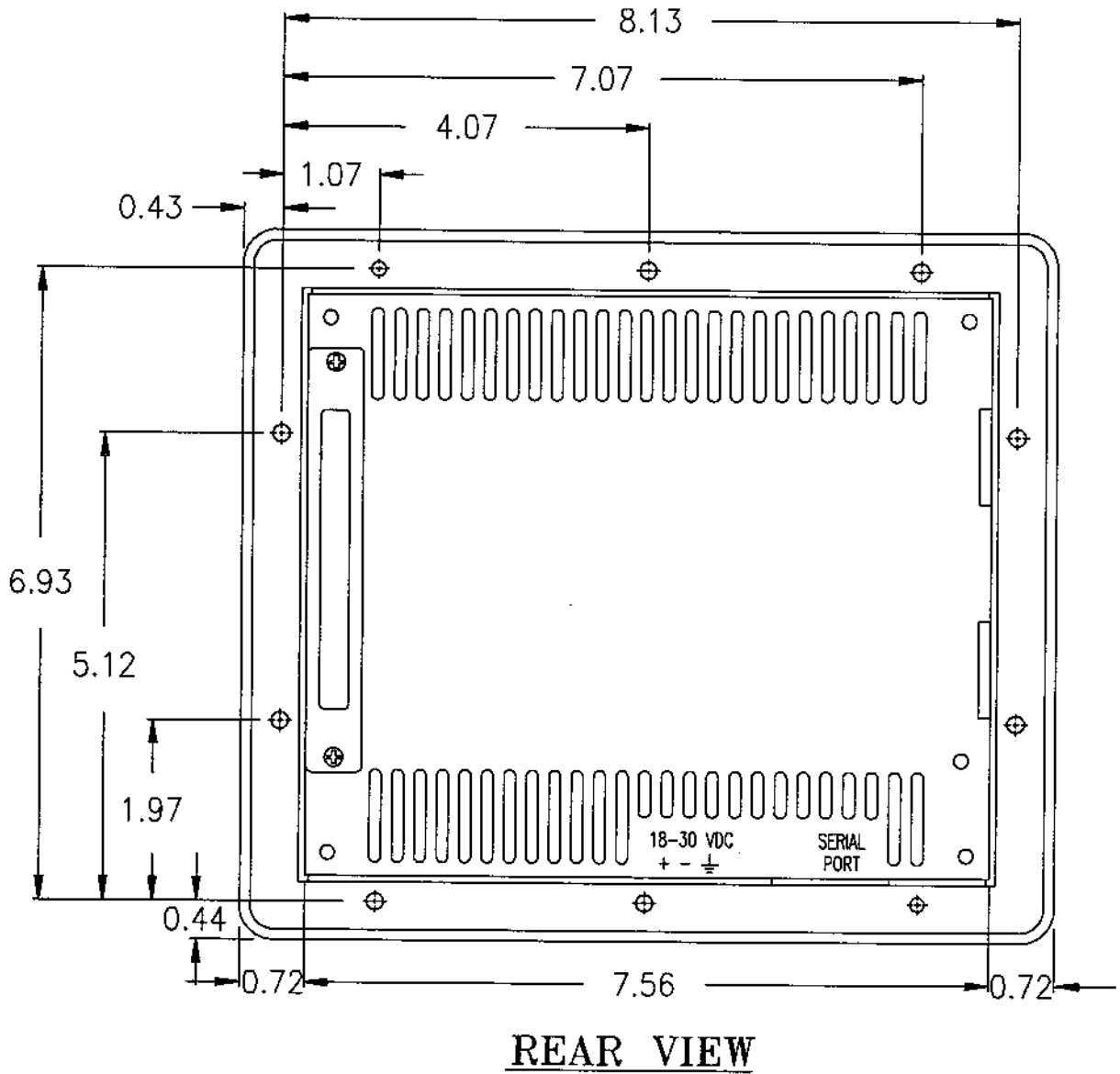
Figure 5-4 PanelMate Series 1000 Cutout and Torque Limits



## REAR VIEW

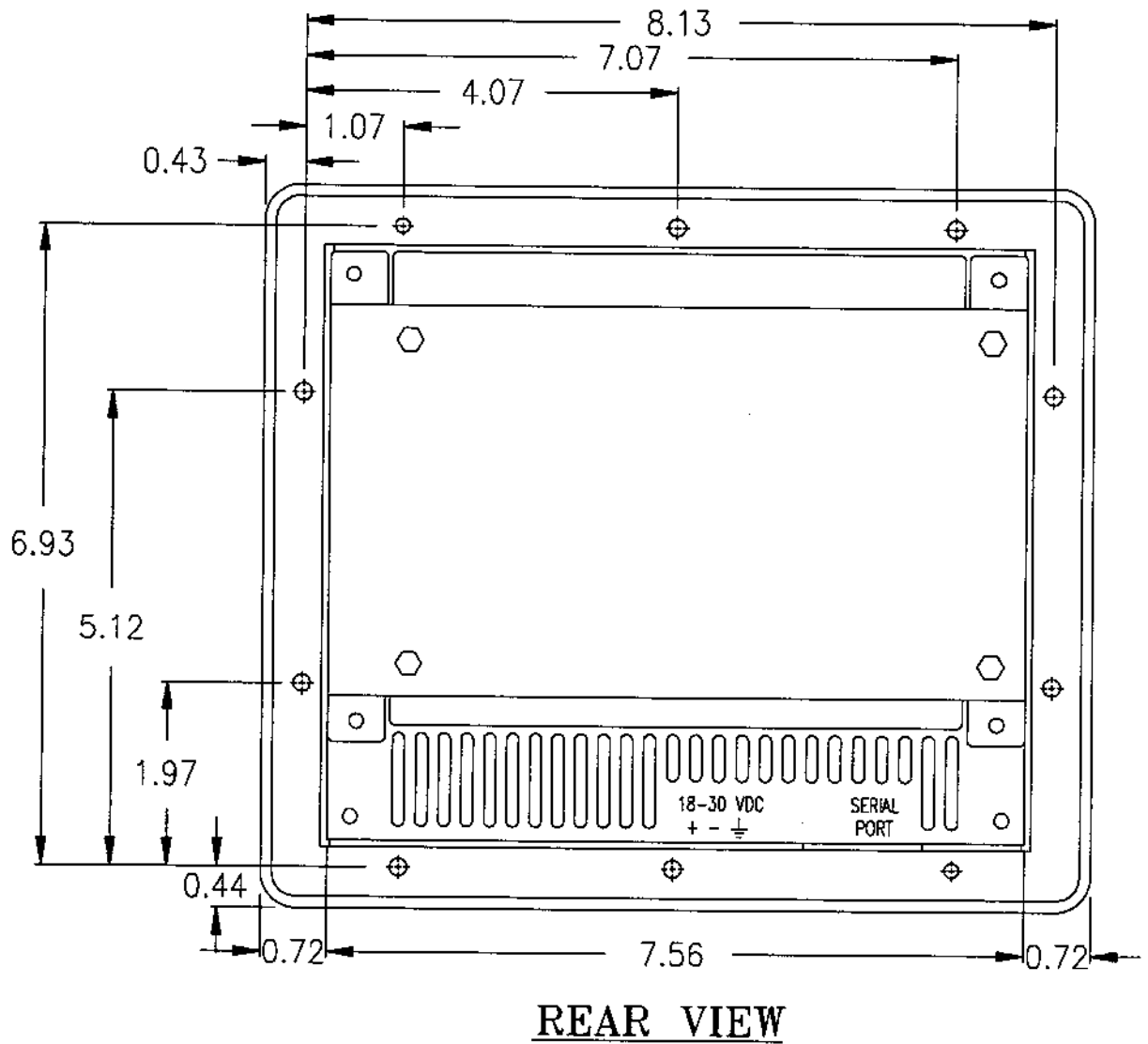
Note: All units are in inches.

Figure 5-5 PanelMate Series 1000 Rear View



Note: All units are in inches.

Figure 5-6 PanelMate Series 1000 with an Accelerat/On Connection Rear View



Note: All units are in inches.

Figure 5-7 PanelMate Series 1000 with Accelerat/On Rear View

## Install PanelMate Series 1000 in Enclosure

---

Make cutouts in the enclosure as show in figure 5-4. To install the PanelMate Series 1000 in an enclosure, use the following procedure:

1. Go to the back of the unit. Remove DC Power and disconnect any other connectors.
2. From the front, insert the unit in the cutout and fasten it with the ten #6 washers and nuts that are supplied with the unit.

### CAUTION

Care must be exercised when tightening the nuts. The fasteners must be tightened enough to obtain a proper seal, yet not be tightened enough to strip the threads from the welded steel studs. Do not exceed 5 inch-pounds.

3. You may now re-connect DC power and any other connectors.

## Connect DC Power

---

The DC power connector receptacle is located at the bottom of the PanelMate Series 1000 unit. The unit will operate at 24V DC. The removable connector is shipped in a plastic bag. Connect your DC power with user-supplied wiring.

Refer to Appendix A, Detailed Specifications, for more information about power requirements.

**Note** It is recommended that noise and surge protectors be used when the PanelMate Series 1000 is installed in areas where the power quality is poor.

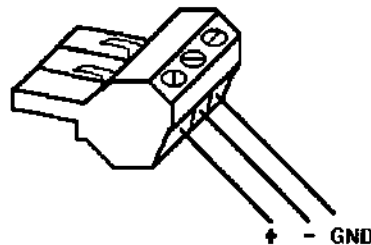
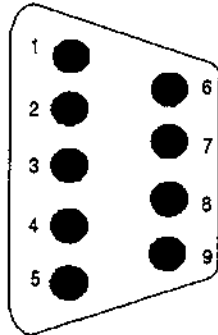


Figure 5-8 Three-Position DC Power Connector

# Connection to the Serial Port

The serial port may be used for a PLC communications or for connection to a personal computer for upload or download.

Port is DB9S (Socket)



- 1 RS422 Transmit Data (+) (Output)
- 2 RS232 Receive Data (Input)
- 3 RS232 Transmit Data (Output)
- 4 RS422 Receive Data (+) (Input)
- 5 Signal Ground
- 6 RS422 Transmit Data (-) (Output)
- 7 RS232 Request to Send (Output)
- 8 RS232 Clear to Send (Input)
- 9 RS422 Receive Data (-) (Input)

# Connection to a Personal Computer

The PanelMate Series 1000 connects to a personal computer to transfer information. You may purchase the serial transfer cable from Cutler-Hammer IDT. This accessory includes a 9-pin to 9-pin cable for connection between a PanelMate Series 1000 and a personal computer. It also includes a 9-pin to 25-pin adapter to permit connection to your personal computer. The cable has the following pinouts.

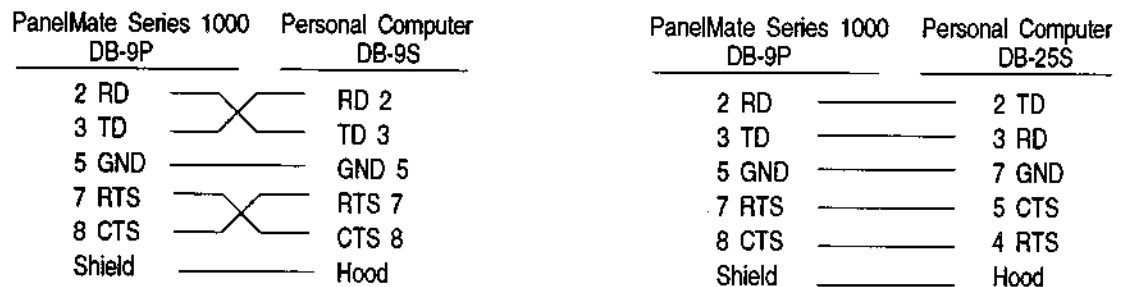


Figure 5-9 Serial Transfer Cable



# Chapter 6

## Online Operation

---

In this chapter, you will learn:

- What happens when you power-up the PanelMate unit
- What happens when you enter the Run Mode
- What to do if an error occurs during startup
- How the Run Mode operates
- What to do if something goes wrong during Run Mode
- What error messages from the PanelMate unit mean

# Power-up Sequence

---

On power-up, the PanelMate unit performs the following sequence of operations:

1. Execute normal power-up diagnostics
2. Check Driver Firmware
3. Check User Configuration compatibility with Driver Firmware
4. Begin online communications with PLC

The following sections describe each of these events more completely.

## Execute Normal Power-up Diagnostics

---

Normal system power-up diagnostics include test of:

- Watchdog
- DRAM Memory
- Serial Port

Each test will be displayed on screen with a PASSED or FAILED message. If the memory test fails, it may not be possible to display a failure message. In the event this type of failure, an alarm tone pattern will be generated which will indicate the actual failure. See Chapter 8, Troubleshooting Guide for the PanelMate Series System, for additional information.

The diagnostics will be performed in approximately 10 to 20 seconds.

If there is a fatal error, you will receive the following message:

```
FATAL Self Test Diagnostic Failures Occurred.  
VCP Unit System HALTED.
```

The system will be completely halted. The only way to reset the system is to cycle power. If this occurs, contact your local distributor.

## Run Mode Initialization

---

The following message will be displayed:

PLEASE WAIT -- ENTERING RUN MODE

At this point in the initialization, the integrity of the Driver Firmware and integrity of the User Configuration has been verified. The PanelMate unit will perform the following initialization procedure outlined below.

1. Verify User Configuration
2. Check the revision levels of the Driver Firmware and User Configuration to determine compatibility
3. Verify PLC Name and Port Table
4. Load System Parameters
5. Create the Run Mode data base and verify all expressions and PLC references
6. Allocate DRAM memory
7. Begin PLC communications
8. Control bit resets; every control bit reference in a PLC will be written to zero. Also send remote bits (Enable Fault Relay) to PLC. Note that if PLC communications are not valid, the communication retry process could be lengthy.
9. Remote send of Startup page information to PLC

The procedure may require between 20 to 100 seconds to initialize, depending upon the complexity of the configuration. The complexity of the user configuration is determined by the density of the pages, number of alarm conditions, and the number of control bits which must be initialized in the PLC(s).

**Note** If a configuration is too large to fit in the PanelMate unit, the PanelMate unit will attempt to go online indefinitely or display a watchdog timeout message. It is suggested that the Configuration Verifier (accessed by the "Verify a Configuration" selection from the Main Menu) be executed on every configuration before downloading to a PanelMate unit for online information.

# Run Mode Operation

---

The online system performs three basic tasks: Screen Updating, Alarming, and Remote Operations. Screen Updating refers to the updating of the currently displayed page based on changes to reference values. Alarming refers to the determination of alarm conditions. Remote Operations refer to receiving or sending Remote bits such as Silence Alarm or Automatic Page Change to or from the PLC.

During the Run Mode, up to three separate scans may be occurring. All scans can be done at a user-specified rate. The scans are Page Scan, Alarm Scan, and Message Scan.

The Page Scan scans for only the references on the currently displayed page to provide current status. The Alarm Scan scans for all alarm references, no matter what page is currently being scanned. The Message Scan scans for references in the message library.

Proper Run Mode operations will only occur if a programmable controller or other intelligent device is properly communicating with the PanelMate unit. In Run Mode, a variety of operations will take place; some are related to the display functions of the PanelMate unit, and some are related to the operator input functions. The following sections describe the Run Mode functions of the PanelMate unit.

## Page Title Line

---

The top line displays the page title of the currently displayed page. It also displays the System Overview field. Additionally, the status of the Password A and Password B are displayed on the line by the letters A and B respectively. The letter will be displayed if the password is valid for operator entry. If the PLC Page Change feature is used and a page change is pending, a flashing cursor will be displayed to the right of the letter B.

## System Overview

---

The System Overview is located between the page title and the alarm window.

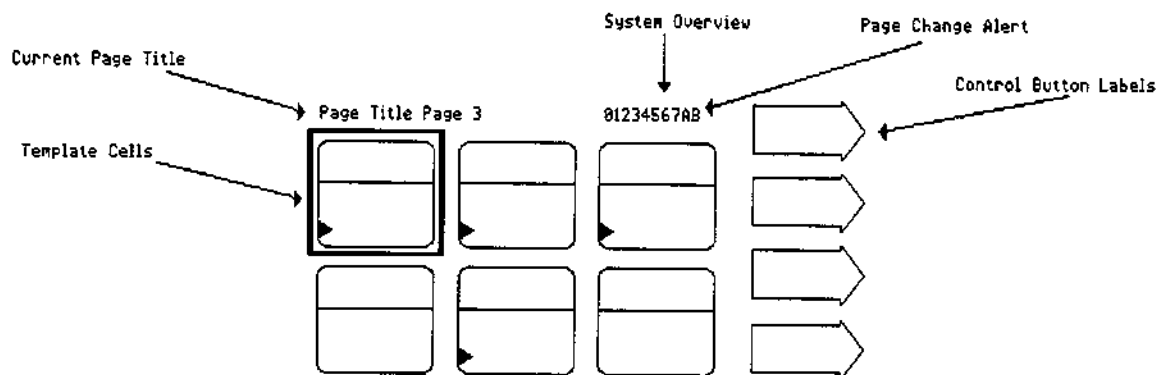


Figure 6-1 PanelMate Series 1000 Page Layout

The display attributes of the page numbers provide the following information to the operator:

Blank	This page has no information on it. The page number will not appear.
Configured	This page is configured and all devices are operating normally. The page number will appear in normal video.
In Alarm	One or more devices on this page are in an alarm condition. The page number will blink.

## Default Control Button Labels

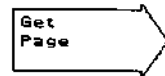
---

The default control button labels will appear when the system powers up in Run Mode, when the <CANCEL> button is pressed, or when operator input is completed, or when the automatic cancel feature takes effect.

A rectangular button with a right-pointing arrow shape on its right side. The text "Silence Alarm" is centered inside the button.A rectangular button with a right-pointing arrow shape on its right side. The text "Reset PLC Com" is centered inside the button.

**Note** "Silence Alarm" will always appear even if there are not any alarms.

"Reset PLC Com" only appears for communications errors.

A rectangular button with a right-pointing arrow shape on its right side. The text "Get Page" is centered inside the button.

Press "Get Page" and the following control buttons will appear.

A rectangular button with a right-pointing arrow shape on its right side. The text "Adjust Contrast" is centered inside the button.A rectangular button with a right-pointing arrow shape on its right side. The text "Alarm Page" is centered inside the button.

Enter  
Page #

## Call a New Page

---

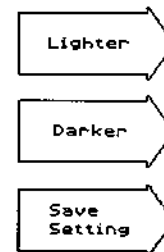
The first page to appear when entering Run Mode will be Page 0, unless you have defined a different start-up page when editing the System Parameters Table. From the default control button selections, select any other page by performing the following tasks:

1. Press the control button labeled "Get Page". The control button labels will change.
2. On the numeric keypad, press the number of the page you wish to select. The new page will appear immediately. If you press the number for the page you are already on, the page is not re-drawn. Press <CANCEL> to remain on the current page and return the control buttons to their default labels.

## Adjusting the Contrast

---

The following control buttons will appear if you press the control button labeled "Adjust Contrast".



You can modify the contrast to meet the needs of ambient lighting where the PanelMate unit is installed. By repeatedly pressing the control buttons labeled "Lighter" and "Darker", you can adjust the contrast of the LCD display through sixteen different levels.

To save the current setting, press the control button labeled "Save Setting". To exit the adjustment mode without saving the changes, press the <Cancel> key.

Note that the screen setting is stored in the PanelMate unit, not in the user configuration. The PanelMate unit will return to the last saved contrast level after power is applied to the unit.

## PLC Page Selection

---

The PanelMate unit has the capability to monitor a register in the PLC and change the page shown on the screen automatically.

The Page Change Register field (described in Systems Parameters Table Editor) holds the reference used to select which page to place on the screen. When a valid page number is in this register, if a template is not selected in the current page, that page will be recalled to the screen. If control is currently selected on the PanelMate Series 1000, a cursor located to the right of the letter B in the System Overview field will blink, indicating a change in the page register. Once control is relinquished, the page referenced in the register will be recalled.

**Note** If the "Immediate Page Change" field in the System Parameters Table Editor is set to Y, the page will change immediately regardless if control is selected.

## **Operator Input**

---

All operator input requires at least two keystrokes. This prevents any accidental entries that could be made by mistaking a control button or numeric key.

Any template that displays a small arrow in the lower left-hand corner of the template can be controlled by the operator.

Before any change can be made to a particular template, that template must be selected. To select a particular template, press the TouchPanel to move the blue box cursor to the location of the template on the screen.

If the template allows control button input, the corresponding control button labels will appear when the template is selected. Press the appropriate control button. If the wrong template is selected before the control button is pressed, simply use the selection keypad to make the right choice. If no selection is desired, press <CANCEL>.

The PanelMate unit's control buttons provide momentary input. When the button is pressed, the PanelMate unit sends a command to the PLC to set the referenced bit to a 1. When the button is released, a separate command is sent to set the bit to a 0, thus providing a momentary input to the PLC. If a maintained input is desired, the bit may be latched in PLC logic. Note that two or more buttons may be pressed at the same time.

If the template requires numeric keypad input, the label of control button 3 will read "Change Value" when the template is selected. The control button labels will immediately change to read "Clear" and "Enter". Use the numeric keys to write the value onto the screen, then press the control button labeled "Enter" to transmit the value to the PLC. If the wrong number is selected before the control button is pressed, simply press "Clear" and try again. If no selection is desired, press <CANCEL>.

The PanelMate unit's commands for control button and numeric input will not overwrite PLC ladder logic, only PLC data memory.

## **Alarms**

---

All alarm conditions that you designate in the PanelMate unit's template editors are constantly monitored. When an alarm condition occurs, the page which contains the alarm will be identified in the system overview field.

Alarm conditions can be selected for audible alarming. The Alarm Horn can be silenced two different ways. The Alarm Horn can be silenced by pressing the control button labeled "Silence Alarm" from the default control button selection. The Alarm Horn can also be silenced remotely by setting a bit in the PLC. See Chapter 22, Defining Systems Parameters, for more information on configuring the Remote Silence Alarm Bit. The PanelMate unit can also set a bit in the PLC when the control button "Silence Alarm" is pressed. This can allow one operator to silence all Alarm Horns on all the PanelMate units on a network.

The alarm message always includes:

- the page number (0-7), e.g., P5
- the template number (1-6), e.g., T2
- the nature of the alarm (high alarm, low alarm, or the alarm condition template label)

Additionally, the following attributes also apply to alarm messages, depending on the condition being reported:

New alarms	New alarms are displayed as blinking text.
Acknowledged	Acknowledged alarms are displayed as reversed video text. The abbreviation "Ackd" will appear in the message.
Cleared, not acknowledged	Cleared alarms that have not been acknowledged are displayed as normal text. The abbreviation "CIRD" will appear in the message.
Cleared and Acknowledged	The message will disappear from the screen.

## Alarm Page

---

To view and/or acknowledge alarms, you must press the control button labeled "Get Page" and then press the control button labeled "Alarm Page". Lastly, you must press the control button labeled "View/Ack Alarms". The control buttons will immediately change and a small, blue block cursor will mark the most current alarm, located at the top of the alarm window.

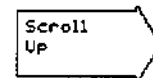
These control button labels will appear:

To acknowledge a single alarm, move the block cursor using the "Scroll Up" or "Scroll Down" buttons to mark the alarm. Then press the control button labeled "Ack Alarm" to acknowledge.

To acknowledge all new alarms, press the control button labeled "Ack All Alarms". It does not matter where the block cursor is located. This action acknowledges all new alarms, whether they are actually in view or not.

The alarms can also be acknowledged remotely. Once the Alarm Acknowledge Bit (defined in the System Parameters Table) is set, all alarms will be acknowledged.

The PanelMate unit is also capable of setting a bit in the PLC when the "Acknowledge All Alarms" control button is pressed. The Remote Alarm Acknowledge Bit is also defined in the System Parameters Table. This capability, along with the ability to remotely acknowledge all alarms, can be useful in allowing one operator to acknowledge all alarms on a network of PanelMate units from a single system.



# Password Protection

---

Passwords can be used to restrict access to certain functionality when the PanelMate unit is in the Run Mode. The PanelMate unit supports many levels of password protection. A great deal of flexibility is provided so it is important to define an implementation scheme before configuring your passwords. There are two levels of protection: Password A and Password B. Passwords A and B are configured in the System Parameters Table. (Passwords can be enabled or disabled to permit or prohibit change during online operation.)

Passwords can be configured by the user for use in the following areas in the Run Mode. Passwords must be enabled for entry each time they are selected.

Templates with Numeric Entry selected:

- Readout Template
- Bar Template
- Table Template
- Maintenance Template

The following combinations of Password Protection are available:

- None
- A Only
- B Only
- A or B

Password protection can also be invoked to protect access on a Page-by-Page basis and can be implemented in many ways. Examples of usage are defined below:

- Page 7, the machine parameter page, protected with Password A
- Reset Part Counter Readout Template protected with Password A
- Operating Temperature Setpoint Readout Template protected with Password B

# Errors During Run Mode

---

During Run Mode operation three basic conditions are checked: proper communications with PLC or host computer, proper operation of the microprocessor, and proper operation of the Driver Firmware. The first check is classified as a Communication Error. The two types of Communication Errors are local errors and remote errors. The last two checks are classified as System Errors. The following sections expand upon these errors.

## Communication Errors

---

The PanelMate unit is a video control panel that can interface with a single PLC or multiple PLCs on a network. It provides predictable fault responses with the occurrence of communication errors. A communication error is a major fault in most control systems. It indicates a breakdown in communication between the PanelMate unit and a PLC. It is the Control System Designer's responsibility to define how the operator should respond to an error.

When a communication error occurs, an error message is written to the bottom of the PanelMate unit screen.

Integrity of the communication link to the PLC is monitored by ensuring that proper responses are received for each transmission that the PanelMate unit makes. If a communication attempt fails, the PanelMate unit will re-transmit a request several times before reporting a communication error. When a communication error is detected, an error message is displayed at the bottom of the screen. Communications with operational PLCs will continue.

When a communication error exists, the continual re-transmission of messages may begin to slow system response. Every PLC write transmission is sent, then re-tried and then discarded. The frequency of the re-transmission gradually decreases to five minutes if requests continue to fail over a prolonged period of time. This feature effectively prevents failing requests from slowing network communications. If the operator inputs control buttons faster than the transmission rate of the network during communication errors, the PanelMate unit will buffer PLC writes in order to ensure that all control commands are processed. When the communication error clears, the buffered control button writes will be sent in rapid succession.

**Note** If blank templates appear on the screen, a communication error has occurred. The operator should not attempt to perform control with blank templates as this may cause control buttons to be buffered in the PanelMate unit. Buffered control buttons may be sent in rapid succession when the communication error clears and may result in undesirable control system operation.

The data at the time of a communication failure will remain on the current page. All data from other PLCs which are communicating correctly will be displayed as usual. If the communication error continues to exist and you select a different page, then no data from the PLC with errors will be shown on the newly selected page. For example, if the page contains a readout template, no numerical data from the PLC with the communication errors will be shown. Once the communication problem is corrected and the control button labeled "Reset PLC Com" is pressed, the page will be re-drawn. Any references to a PLC which are not communicating will not be re-drawn until valid communications have resumed. If the communication error still exists, a communication error message will be displayed on the bottom line of the screen.

**Note** Pressing the control button labeled "Reset PLC Com" may still cause invalid information to be displayed. For example, if an expression for a bar template value contains a reference to a PLC which is communicating and also to a PLC which is not communicating, the bar will be updated on the screen even though invalid data may appear on the screen.

Once a communication error appears, the operator should first note the page status. The data is a snapshot in time of the last valid communication. The next action is to try to clear the error by pressing the control button labeled "Reset PLC Com". This restarts attempts at communications. If the condition causing the error no longer exists, the screen is updated with dynamic information. If the error remains, the communication error message is written to the screen. If values could not be read due to the lack of communications, then templates will be displayed as blank.

If blank templates appear on the screen, it means that communications have not re-established. The operator should not attempt to perform control with blank templates because the actual state of the machine or process cannot be determined. If the operator continues to press control buttons, data may be sent faster than the communication link which is in error can handle them. The PanelMate unit may buffer the control requests until communications have re-established. This may result in control bits being sent to a PLC in rapid succession which may cause undesirable operation of the control system.

Communication errors can be cleared by pressing the control button labeled "Reset PLC Com" or changing pages provided the reason for the error no longer exists.

Integrity of the communication link to the PLC is monitored by ensuring that proper responses are received for each transmission that the PanelMate unit makes, according to the specific protocol in use.

Communication problems can include:

- Broken or incorrect cabling to the PLC
- PLC or interface card failure
- Incorrect setting of PLC interface card switches
- Removal of a PLC from the active network
- Attempt to access a non-existent PLC address
- Attempt to write to a protected PLC address
- Too much traffic on a PLC network

The PanelMate unit will try to re-transmit a request several times before reporting that a communications error has occurred. Unlike system errors, communication errors do not halt the PanelMate system. The PanelMate unit continues to re-transmit requests indefinitely, even after an error has been reported.

The frequency of the re-transmission gradually decreases to five minutes if requests continue to fail over a prolonged period of time. This feature effectively prevents failing requests from conflicting with other communications.

The two types of communication errors are local errors and remote errors.

Local errors are reported on the bottom of the screen as follows:

L: X O R N

where

- X is an internally generated communication error code which indicates the nature of the problem. Refer to table 6-1 for the error code listing and description.
- O is the operation being performed
- R is the reference
- N is the PLC name in the PLC Name and Port Table

Remote errors are reported on the bottom of the screen as follows:

R: X (Yh) O R N

where

- X is a generated communication error code from a remote device. Refer to your PLC user manual for more information on this error code.
- Yh is the error displayed in hexadecimal format
- O is the operation being performed
- R is the reference
- N is the PLC name in the PLC Name and Port Table

**Note** If you are using Allen-Bradley PLCs, a complete set of error codes can be found in the Allen-Bradley Publication 1770-6.5.16, November 1991. Take note of the hexadecimal error code and consult the Allen-Bradley publication. If the remote error code is F0XX (hex), then the XX represents the EXT STS (extended status). The EXT STS codes are found in the EXT STS Codes for Command Code 0F (hex) table. Other remote error codes are found in the Remote STS Error Codes table.

When a communication error is reported, the system continues to operate. Other PLC transmissions will be attempted and processed. Transmissions which have failed will be re-attempted until normal communication is re-established. Each time the error is detected, the message will be reprinted at the bottom of the screen. The data at the time of a communication failure will remain on the current page. If a different page is selected, no data from the PLC with errors will be shown. For example, if the page contains a readout template, no numerical data from the PLC with the communication errors will be shown. The numerical area will be blank. All data from other PLCs which are operating correctly, will be displayed as usual. Once the communications problem is corrected and the control button labeled "Reset PLC Com" is pressed, the page will be re-drawn. Any templates which reference a PLC which is not communicating will not be re-drawn until valid communications has resumed.

## System Errors

---

During Run Mode operation, two basic conditions are checked in the PanelMate unit: proper operation of the CPU, and proper operation of the system software.

Proper operation of the microprocessor is monitored by a Watchdog Timer. If a microprocessor error is detected, the screen will display "Watchdog Timeout. Press Cancel Key to Continue" and the system is halted.

One possible reason for the Watchdog Timeout error could be related to the power. Check to make sure that the PanelMate unit is properly installed. If problems still occur, call your local distributor for more information.

Proper operation of system software is monitored to ensure that all internal processes are active and functioning normally. If a system software error is detected, the system is halted.

An error message is displayed at the bottom of the screen:

S: X O P (P) (P)

where

- X a system error code which indicates the nature of the problem. Refer to table 6-1 for the error code listing and description.
- O is the operation being performed
- P is an internal error code. This error code may appear more than one time.

**Note** If these error messages appear, please call your local distributor.

Error Number	Description	Possible Cause
0	Undefined error.	
1	Software module not found or corrupted.	
2	Out of memory.	
201	Bad or missing communication card.	
244-246	Read/write error.	Cabling is wrong. RS232/RS422 converter is bad or missing. Excessive noise on communication line.
253	Acknowledge not received from the remote device or remote device did not reply to request in allotted amount of time.	No communication, PLC is busy, invalid network ID, or wrong communication parameter. VCP unit could be receiving too many unsolicited messages.
1000	Internal system error code.	Invalid configuration. Bad PLC Name and Port Table
1001	Serial port buffer overrun.	PLC is locked in transmit mode. PLC is transmitting too much data.
1002	Error on input.	Wrong communication parameters. Intermittent hardware failure. RS232/RS422 converter is bad or missing (Mitsubishi FX/FXo)
1003	Error on output.	Wrong communication parameters. Intermittent hardware failure.
1100	Device descriptor cannot be generated.	Out of memory or module cannot be found.
1101	Device cannot be opened.	Missing module. Serial controller or I/O board is bad. Missing or bad hardware. Accelerat/On board is not installed.
1102	Expected data was not received.	Communication has been established. VCP has started to read data, but has timed out. (This error is usually followed by a 1202 or 1702 error.)
1103	Support process cannot start.	Out of memory, module is corrupted, or module cannot be found.
1104	Device cannot be opened.	Missing module. Serial controller or I/O board is bad. Missing or bad hardware. Interface board is not installed.
1125	Framing error.	Wrong communication parameters.
1126	Parity error.	Wrong parity.
1127	Overrun error.	Wrong communication parameters or no communication.
1128	Hardware break.	Grounding, shield, or termination problem.
1150	Data Highway, Data Highway Plus, and Accelerat/On error - the Accelerat/On card has detected an error during its memory diagnostics.	
1151	Data Highway, Data Highway Plus, and Accelerat/On error - the Accelerat/On card would not restart.	

Table 6-1 Local and System Error Code Descriptions

Error Number	Description	Possible Cause
1151	DH-485 - destination buffer not big enough to receive message.	
1152	DH-485 - message too big to transmit.	
1153	Data Highway, Data Highway Plus, and Accelerat/On error - the Accelerat/On card has no transmit buffers available.	The Accelerat/On card is receiving unsolicited data (MSG's) too fast.
1153	DH-485 - received NAK from destination	Normally received if destination has too many outstanding requests.
1154	Data Highway, Data Highway Plus, and Accelerat/On error - the Accelerat/On card would not respond to the interface software's command.	Accelerat/On card hardware failure.
1154	DH-485 - timeout, no response from destination after 3 retries.	Invalid ID or PLC type.
1155	DH-485 - duplicate node detected.	Two devices on highway have same network ID (node #).
1156	DH-485 - data link is not active (link timeout). VCP unit is not passing token.	Missing or bad cable. Noise on communication line.
1157	DH-485 - application timeout (destination active, but not responding).	
1158	DH-485 - VCP unit has not received token from previous node.	Network communications is disrupted. The cable was disconnected from the VCP unit or the previous node has dropped off the network. (This error is usually followed by an 1156 error.)
1200	Communication active but remote device responded with negative acknowledge. (NAK)	Noise on communication line or wrong parity.
1201	Communication active but remote device responded with negative acknowledge. (NAK)	Noise on communication line or wrong parity.
1202	Acknowledge not received from the remote device or remote device did not reply to request in allotted amount of time.	No communication, PLC is busy, invalid network ID, or wrong communication parameter. VCP unit could be receiving too many unsolicited messages. (This error is driver dependent.)
1203	VCP unit rejected communication from PLC.	Noise on communication line or wrong parity.
1250	Could not establish link with Square D PLC.	
1250	Could not synchronize with Westinghouse PLC.	
1250	Reliance AutoMate gateway not configured.	No communication, PLC is busy, or invalid network ID. VCP unit is unsuccessfully trying to reconfigure. Reliance gateway module. Dipswitches are configured wrong. Power loss to gateway module. Intermittent error.
1250	Channel prematurely closed by GE CCM.	VCP unit too busy to close channel.
1250	Communication to GE with SNP was out of sync.	VCP unit too busy to accept reply or noise/cable problems.

Table 6-1 Local and System Error Code Descriptions (cont.)

Error Number	Description	Possible Cause
1251	Open channel request was refused by GE CCM.	GE CCM card is too busy to open channel. Noise on communication line to GE or wrong parity.
1251	Reliance AutoMate processor not found in destination slot.	
1251	VCP unit cannot set privilege level in GE PLC (SNP).	Communication error while trying to set privilege or other device has set privilege.
1252	More than one Reliance AutoMate processor in the rack.	
1700	Communications out of sync.	Duplicate token, noise, or busy device causes VCP unit to timeout and PLC responds to previous request.
1701	A reply was received for which there was no request issued.	Scan delays are too large.
1702	Acknowledge not received from the remote device or remote device did not reply to request in allotted amount of time.	No communication, PLC is busy, invalid network ID, or wrong communication parameter. VCP unit could be receiving too many unsolicited messages. (This error is driver dependent.)
1703	Internal system error code.	
1705	This interface does not support any unsolicited requests from a remote device.	
1706	Received an unsolicited command that is not supported.	
1707	The remote device memory type is not supported.	
1708	Cannot write to read only reference.	
1750	Siemens follow-on telegrams are not supported.	PLC sending too much data.
1750	Block transfer not detected on Remote I/O.	
1750	Data Highway and Data Highway Plus - does not support PLC-3 address format.	
1750	DH-485 - I/O word number out of range.	
1751	Remote I/O - rack is not active or configured.	
1751	Data Highway and Data Highway Plus - symbolic word and addressing mode is not supported.	
1752	Remote I/O - PLC is in test or program mode.	
1752	Data Highway and Data Highway Plus - symbolic file and addressing mode is not supported.	
1753	Remote I/O - remote rack is in a faulted condition.	
1754	Remote I/O - communications not active.	On a PLC-3, if communications do not recover on the VCP unit, check the revision of the EPROM on the AcceleratI/On card. The revision must be 05 or greater (P/N 85-00285-05 or 85-00307-05).
1755	Remote I/O - block transfer count is too small.	
1761	Allen-Bradley error code 01 - remote device could not take message.	Not enough memory in an older PLC 5/15 and/or 5/250. Too much traffic on device.

Table 6-1 Local and System Error Code Descriptions (cont.)

Error Number	Description	Possible Cause
1762	Allen-Bradley error code 02 - remote device does not acknowledge.	VCP unit is communicating properly on the highway, but the remote device cannot be found. (Wrong network ID.) Remote device is bad or missing.
1763	Allen-Bradley error code 03 - unrecognized response from remote device.	Duplicate token holder detected or general network error.
1764	Allen-Bradley error code 04 - local port is disconnected. (Data Highway Plus only)	Not passing token. VCP unit is disconnected from highway or improperly connected. Noise on communication line.
1766	Allen-Bradley error code 06 - duplicate node detected.	Two devices with the same network ID (node #).
1767	Allen-Bradley error code 07 - station is off-line.	
1768	Allen-Bradley error code 08 - hardware fault.	
1774	Allen-Bradley error code 0E - VCP unit received duplicate transaction number.	Communications out of sync.
2000-2002	Internal system error code.	Driver corrupted. (Re-download driver.)
2100	Internal system error code.	Configuration and driver could be incompatible.
2101	Invalid reference. Cannot parse.	(Check PLC reference syntax.)
2102	Invalid reference. Cannot parse.	(Check PLC reference syntax.)
2103	All PLC references in current block are invalid.	Check all references to same memory area.
2105	Could not update database via block read.	Possible hardware problem. Internal data structure corrupted.
2106	Could not update database via unsolicited request.	PLC sending unsolicited to VCP memory area that does not exist.
2107	Remote interface supports only one block read.	
2120	Invalid bit write register.	GE CCM or TI Host Link bit write registers are invalid.
2200	Unsolicited request failed. Connection not established with remote device yet.	PLC is sending unsolicited data before VCP unit is ready to receive it.
2201	Inconsistent local address.	Network ID and interface board ID do not match.
2500	Invalid separator.	Check PLC references.
2501	Invalid reference. Cannot parse.	Invalid character in PLC reference.
2502	Invalid reference. Cannot parse.	Not enough characters in network address or PLC reference.
2503	Invalid reference. Cannot parse.	Too many characters in network address or PLC reference.
2525	Network address component out of range.	The network ID or PLC ID configured is out of range.
3000-3005	Internal system error code.	Driver is corrupted. (Download new executive firmware/drivers.)
3025	Network address (PLC ID field) is invalid or out of range.	

Table 6-1 Local and System Error Code Descriptions (cont.)

Error Number	Description	Possible Cause
3050-3055	Internal system error code. Data buffer corrupted.	Baud rate is too slow.
4100	Invalid network ID.	
4101	Invalid network ID.	
4102	Not enough network ID levels specified.	
4103	Too many network ID levels specified.	
4104	Invalid network ID.	

**Table 6-1 Local and System Error Code Descriptions (cont.)**

# Chapter 7

## Regular Maintenance

---

In this chapter, you will learn:

- What regular maintenance the PanelMate Series 1000 requires

## Regular Maintenance

---

Very little regular maintenance is required to keep your PanelMate Series 1000 in perfect running condition.

The face of the unit should be cleaned, whenever needed, with any common, non-abrasive cleaning product.

Every 3 to 6 months, run all the system health checks that are provided in the system. These include the Display Tests and Membrane Keypads Test. Refer to Chapter 4 for directions on running these system health checks.

It is best to mount the PanelMate Series 1000 in a closed industrial enclosure. However, if a PanelMate Series 1000 is operating in a dusty environment and is unprotected (e.g., mounted in a control panel whose door is often left open), periodically use forced air to blow off any dust that may have accumulated on the circuit boards. Be sure to disconnect power before conducting this procedure.

There are no user replaceable fuses or batteries in the PanelMate Series 1000.

# Chapter 8

## Troubleshooting Guide for the PanelMate Series System

---

This section of the manual is provided to help you determine if problems you are having with the PanelMate unit can be readily solved on your own or require help from Cutler-Hammer IDT's Customer Service Department.

Please try all recommended solutions of your problem before contacting your local distributor.

## **Problems with the Monitor**

---

### **No picture on the screen**

Make sure the power is switched ON.

Make sure your power source is actually supplying power to the PanelMate unit.

### **Watchdog timeout message on a screen that says "Watchdog Timeout. Press Cancel key to continue"**

A watchdog timeout error may indicate a problem with PanelMate hardware or it may be related to AC power. If problems persist, call your local distributor. Please have the unit's serial number ready for the distributor who serves your call.

## **Problems with the TouchPanel**

---

### **Keyboard does not work at all or one or several membrane keys do not work**

Check the integrity of the cable and connectors.

Use the Membrane Keyboard Test to check if the keys are sending a signal to the PanelMate unit (refer to Chapter 4, Execute the System Diagnostics).

## **Problems with the Control Buttons**

---

### **One or several buttons do not work**

Use the Membrane Keyboard Test to check if the keys are sending a signal to the PanelMate unit (refer to Chapter 4).

## **Problems with Audio Output**

---

### **No sound is produced at all or sound is only produced for operator input or alarms**

Check the System Parameters Editor to make sure you have the audio output set to ON (refer to Chapter 22).

## Problems with Serial Port

---

### **Cannot establish communication using the serial port**

If serial communication is a problem, always check the cable integrity. Check to make sure pins are not missing or wires are not broken. You should also check to make sure the communication parameters (baud rate, stop bits, parity, etc.) match in both the PanelMate unit and the PLC.

To test the serial port, place the PanelMate unit in the Transfer Mode and use the DOS-based software in the Transfer Mode to Read System Information from the PanelMate unit. This will verify communications.

You can also execute the System Diagnostics and perform the serial port test. This requires two special loopback test plugs for proper operation. For more information on this procedure, refer to Chapter 4, Execute the System Diagnostics.

## Problems when Transferring Memory

---

### **Cannot make a PC (Personal Computer) transfer at all**

Make sure that the cable connecting the PC serial port to PanelMate Serial Port is the one sold by Cutler-Hammer IDT.

Check the integrity of the PanelMate communications port. Do this by restarting the system (power off, then re-power) and noting the report of the power-up diagnostics. Make sure you are connected to the PC serial port selected in the Utility Parameters Editor.

### **Cannot download from the PC**

The file you are attempting to load from the PC may be corrupted. Re-save the configuration to the PC, then try to transfer the configuration again.

# Specific Error Messages

---

## **Error encountered during initialization of data structures**

Return to the Configuration Mode and check the PLC Name and Port Editor. Especially verify all Network ID numbers and the default PLC. A default PLC must be named, even if you are using one PLC.

## **Error in memory checksum calculation**

This error message indicates that all or part of the system configuration memory is corrupted. Most commonly, this error is displayed after improperly exiting a system editor. To correct this error, recalculate the checksum by entering and exiting the editor as normal.

## **Errors identified by audible tones when message display is not possible**

For certain fatal startup errors which do not permit fault messages to be displayed on the screen, the PanelMate unit will generate special alarm tones.

If the video subsystem has fatal errors, an alarm tone pattern is generated to indicate the actual failures. A 1000 Hz tone with .25 seconds duration indicates a test has passed. A 800 Hz tone with .5 second duration indicates a test has failed. A 3 second pause occurs at the end of the tone sequence. The tests are performed in the following order:

- Display Failure
- Serial Port
- DRAM
- Watchdog

# Chapter 9

## Initialization of the Configuration Software Package

---

In this chapter, you will learn:

- The hardware requirements of the personal computer which runs the software package
- How to run Setup
- How to start the Configuration Software Package
- The file naming conventions
- Compatibility with various personal computer platforms

# Overview

---

The PanelMate Configuration Software Package is a collection of integrated editors which run on an IBM PC or compatible computer. The package creates application software for the PanelMate online system, allowing you to perform the following tasks:

- Create and edit a complete configuration, including pages, message library, system parameters and PLC connection information.
- Document a configuration.
- Check memory requirements of a configuration when running online.
- Perform file management operations on configurations.
- Download a configuration or PLC driver to the PanelMate system. The software will also upload and store a configuration from a system.

The IBM personal computer or compatible computer must meet the following requirements to run the PanelMate Configuration Software properly:

- AT-compatible
- DOS 3.1 or later
- VGA
- 640K
- 4 1/2 MByte of free disk space

## Personal Computer Hardware Requirements

---

The PanelMate Configuration Software will operate on DOS-based computers (IBM PC and compatibles) running DOS version 3.1 or later. The software is not designed to operate under any other operating system designed for the IBM PC, such as UNIX/XENIX or OS-2. The software is not designed to run under Microsoft® Windows™. The software will run on PS/2 hardware.

The Configuration Software requires a minimum of 640K RAM and requires over 500K free memory in DOS to operate. It will support Expanded Memory Specification (EMS) version 3.2 or higher and Extended Memory Specification (XMS) version 2.0 or higher for caching overlay files, but neither is required. The software must be copied from floppy diskette and loaded onto a hard disk. The configuration software and two PLC drivers requires approximately 4 1/2 MByte of hard disk. To conserve hard disk space, only load the PLC drivers that you will be using. There should not be any terminate, stay-resident (TSR) programs running with the software. If memory problems occur, verify that a large amount of memory is not being used by TSR memory programs or device drivers in your **config.sys** file.

The software will operate with color, monochrome, gas plasma, or LCD monitors or displays. Although color may be used in the prompts in the Configuration Software, the screen images for the pages will be developed in monochrome for the PanelMate Series 1000.

The software was designed for use with computers having VGA video adapters and operating in Graphics Mode. VGA (and SVGA) video adapters provide What-You-See-Is-What-You-Get (WYSIWYG) on monochrome and color monitors. The software will not function with non-VGA video adapters such as MDA, HGC, HGC+, HIC, CGA, MCGA and EGA.

**Note** The Rendition II Graphics Adapter Board is not supported by the PanelMate software since the board does not support CGA, EGA, or VGA standards.

The software is shipped on 3 1/2 inch (high density 1.44M) floppy diskettes. The software is available on 5 1/4 inch (high density 1.2 MByte) floppy diskettes by calling Cutler-Hammer IDT Customer Support at (614) 882-3282.

## Running the Setup Installation Program

The Configuration Software Package contains an installation program named Setup. Setup is on the diskette labeled "Configuration Software 1". Setup will automatically create the directory structure and load the software on your hard disk. The default directory is C:\VCP1000>. You can enter a new pathname if desired.

To install the Configuration Software Package on your hard disk, insert the diskette labeled "Configuration Software 1" in your personal computer. If the DOS prompt, C:\>, is visible, then type:

```
A: <Return>
```

With the A:\> prompt visible, type:

```
SETUP IDT
```

Follow the instructions that are displayed on the screen. To reduce the amount of hard disk space required to install the software, load only those PLC drivers which you will be using. This utility can be used again at a later time to install additional PLC drivers.

**Note** If you are installing the Configuration Software Package on a partitioned disk, make sure the partition is physical. A logical partition will not be recognized.

## Starting the Configuration Software Package

---

If the default pathname was used to install the software, at the C:\> prompt, type:

```
CD \VCP1000 <Return>
```

Otherwise, type:

```
CD \pathname <Return>
```

where pathname is the directory defined during the setup installation.

At the C:\VCP1000> prompt or C:\pathname> prompt, type:

```
PMC <Return>
```

If you are using an LCD laptop or other personal computer unit which may startup in a color video mode and are experiencing problems viewing the cursor, go to DOS and type "MODE BW80" to attempt to set the display to a black and white mode. If this does not correct the problem, consult the laptop manual.

## File Naming Conventions and File Management

---

Each saved configuration is stored on the personal computer under a name you choose. The filename extension for configurations for the PanelMate Series 1000 is .PC0 (.PCzero).

The Configuration Software package can also be configured to perform Automatic Saves and Automatic Backups. See the Edit Utility Parameters section in Chapter 11, The Main Menu, for a detailed explanation. If these features are selected, then backup files with the .BK0 extension and save files with the .SV0 extension may be created.

**Note** Use this Configuration Software Package to rename files. Do **not** use DOS. The software not only changes the DOS filename, but it also changes the internal structure of the file so that it contains the proper name for display on the online unit. DOS copy will only change the external reference. See Chapter 27, File Management, for additional information.

## Non-VGA Hardware

---

The Configuration Software is not designed for use with computers having non-VGA video adapters.

# Chapter 10

## Basic Steps for Creating a User Configuration

---

In this chapter, you will learn:

- What steps you should follow for creating a configuration
- What information should be gathered before starting a configuration
- How to make the best use of the PanelMate unit

# Overview of the Process

---

This chapter is written for a new user of the PanelMate unit. It is an overview of the steps required to create a new User Configuration and to transfer it into a PanelMate online unit.

## Step One: Create a User Configuration

---

The first three steps should be done before you run the PanelMate Configuration Software Package.

1. You must determine the optional features that will be used in your unit. Will you use the Modicon Modbus or Allen-Bradley DH-485 options?
2. You must select your PLC Brand and Model. You should also determine the Network ID# for the PanelMate unit and the Network ID# for the PLC(s) if this is applicable for your installation.
3. You should review the Word and Bit Reference section which is at the end of this chapter. This section and the chapter for your brand and model of PLC should be reviewed before you begin configuration. It is best to understand the format for PLC references before your begin a configuration.
4. Run the PanelMate Configuration Software Package.
5. Select "Develop a Configuration."
6. Select "Create a New Configuration."
7. To the prompt "Use an existing configuration as a base", answer no by pressing <N>.
8. Complete the fill-in-the-blank spreadsheet with your choices and enter a name for your configuration. Then press <F1> to enter the Configuration Editor.

If you need further information, see Chapter 12.

9. The first editor you select should be Edit PLC Name and Port Table. Select this item and press <Return> to complete this spreadsheet.

In the Port Parameter section, you should define the following:

- a) Select your PLC type in the USE field for the port which you will used to communicate to the PLC.
- b) Enter the PanelMate Network ID# in the field adjacent to the port which you just configured, if applicable.
- c) Enter the remainder of the communication information.

In the PLC Name Table:

- d) Enter a tagname (up to 6 characters) for the PLC in the NAME field. If multiple PLCs are on the network, enter names for them also.
- e) Define the ID# for each PLC entered.
- f) Match the PORT field to the port you selected in the Port Parameter Table.
- g) Enter the correct MODEL for each PLC entered.
- h) Determine which PLC will be the primary PLC for communications. Enter this name in the DEFAULT PLC NAME field. This will reduce the amount of typing required to reference this PLC.

**Note** You must enter a default PLC name.

Exit the PLC Name and Port Table by pressing <F10> and then <Y> to save the new table.

If you need further information, see Chapter 23, PLC Name and Port Parameters Table.

10. Now from the Configuration Editor Menu choose "Enter Directory Editor."
11. Next select a page to edit. Use the cursor keys in the Page No. column to choose a page number and then press <Return>. If you need further information, see Chapter 13, Directory Editor.
12. Create your pages using the various Page Editors (Chapter 14). Save each page as you exit the Page Editor and return to the Directory Editor.
13. Once your pages are complete, you may wish to select other product features such as the volume for alarm tones, setting of the startup page number and password values. To adjust these settings, select "Edit System Parameters." When complete, press <F10> to exit.
14. Finally select "Exit Configuration Editor" by pressing <F10>. Type <Y> to save the configuration. When the file naming screen appears type <Return> to save the file under the previously defined name.
15. Select "Return to Main Menu."
16. Select "Verify A Configuration." Select your filename and press return to start. The Configuration Verifier checks for invalid PLC references and invalid PLC Name and Port Table information in your configuration. The Configuration Verifier checks all references so that problems can be found and corrected before downloading to the PanelMate unit and attempting to go online. The Configuration Verifier also checks the amount of online memory required to run the configuration. When complete, press any key to continue.

Now that the User Configuration is complete, you must download it to the online PanelMate unit to test it.

## **Step Two: Transfer Files to the PanelMate Unit**

---

First, power-up the PanelMate unit and hold the <Cancel> key until the unit goes to the Offline Mode. Place it into the Transfer Mode by selecting the Enter Transfer Mode template and pressing the "Execute" button. Then connect the configuration cable between your personal computer (COM1) and the PanelMate unit. Use the following procedure to first download your brand PLC Driver and then your User Configuration.

1. At the Main Menu select "Transfer Information."
2. If you are installing options into the PanelMate unit, insert the Option Diskette into the floppy drive and select "Download Option to VCP unit." Choose the option then press <F1> =Start. You will also be prompted to install your PLC drivers.
3. If you are installing a PLC driver and you did not install an option with a PLC driver, then select "Download Driver to VCP unit." Then select your specific PLC and start the download by pressing <F1>= Start.
4. Finally select "Download Configuration to VCP unit." Enter the name of your configuration and then press <F1>=Start.
5. When complete select "Return to Main Menu."
6. To end your session, select "Exit to Dos."
7. With the VCP Unit in the Transfer Mode press the "Cancel" button to return to the offline mode.

You are now ready to test online with your PLC.

## **Step Three: Connect the PanelMate Unit to your PLC**

---

1. Make a communication cable to connect between your PanelMate unit and your PLC. Refer to the PLC chapter for your brand for cabling information.
2. Download the PLC program (if required).
3. Remove the cable used to download to the PanelMate unit and attach your communication cable between the PanelMate unit and the PLC.
4. From the offline mode of your PanelMate unit, select "Enter Run Mode" and execute.

If you ran the Configuration Verifier, the unit should come online without error. If error messages appear at the bottom of the screen, review the explanations in Chapter 6.

If a configuration is too large to fit in the PanelMate unit, the PanelMate unit will attempt to go online indefinitely. As suggested in item 16 of Step One: Create a User Configuration, run the Configuration Verifier prior to downloading the configuration to find and correct potential problems before going online.

## Notes on Online Operation

---

1. If a value is too large to display in a given template, the value displayed will be truncated. The most significant digits will be shown and the least significant digits will not be displayed. Check to make sure the templates are set for the maximum number for digits expected.

Examples:

<u>Value from PLC</u>	<u>Display of Four Digit Value</u>
1234	1234
12345	1234      Truncates the 5
-1234	-123      Truncates the 4

2. If a value with a decimal point is sent to a PLC data type that supports whole integer values, then the value is truncated before it is sent to the PLC.

Example:

<u>Enter</u>	<u>Value Sent to PLC Whole Number Location</u>
1234	1234
123.4	123
123.9	123

3. If only the minus key ("-") or the decimal point (".") is entered for numeric entry, than a value of zero will be written to the PLC.
4. When using factor of ten scaling values in readout, bar and table templates, the number of decimal places in the display format should match with the scaling factor.

Example:

An operator enters a value of 12.45 which must be converted to a 1245 to be sent to an integer location in your PLC. Use the following data entry concept: configure the target word address field to multiply the value by a factor of 100 and sent it to the PLC register reference. The PLC would move the value and manipulate it internally to account for the scaling factor. The integer value would be read from the PLC and multiplied by a factor of .01 and displayed with two decimal places format.

Example for an entry in the Table Template:

Value Expression	[Ref]*.01
Decimal Point	2
Target Word Address	[Ref]*100

Operator Enters 12.45  
Value displayed in Edit column = 12.45  
Value sent to and read from the PLC Reference = 1245  
Value displayed in Current column = 12.45

If the scaling factors and decimal place holder do not match, then the value may not be managed properly by the control system. In the previous example, if the number of decimal places was set to one, then the following would occur:

Operator Enters 12.45  
Value displayed in Edit column = 12.5\*  
Value sent to and read from the PLC Reference = 1245  
Value displayed in Current column = 12.5\*\*

- \* Rounding occurs in the Edit column for display only. The correct value is sent to the PLC.
- \*\* Rounding occurs in the Current column.

# Word and Bit References

---

## Word References

---

A single format for referencing PLC words is used throughout the PanelMate template editors. Whenever you need to refer to a specific PLC word in any expression, the following format is required.

[plcname,word#format]

**Note** *plcname*, and *#format* are optional fields

where

plcname,	The 6-character (or less) name of the designated PLC, as defined in the PLC and Port Parameters Table, followed by a comma. Consult Chapter 23, PLC Name and Port Parameters Table, for more information regarding this name. If this name is omitted, the default PLC name is assumed. (The default PLC is defined in the PLC Names and Port Parameters Editor.) This field is optional.
word	The actual PLC reference number of the word to be read or written, using the addressing nomenclature of the PLC defined by the <i>plcname</i> . Consult the specific PLC section for more information about word reference numbers.
#format	The 3- or 4-character code that specifies the format to be assumed for the data being read or written, preceded by a number sign (#). If this format is omitted, default formats will be used. The formats that the PanelMate unit recognizes are: <b>S16</b> Signed, 16-bit integer where the number can range from -32768 to 32767; the high order bit is the sign. <b>U16</b> Unsigned, 16-bit integer where the number can range from 0 to 65535. <b>S32*</b> Signed, 32-bit integer where the number can range from -2,147,483,648 to 2,147,483,647; the high order bit is the sign. <b>U32*</b> Unsigned, 32-bit integer where the number can range from 0 to 4,294,967,295. <b>BCD3</b> 3-digit binary-coded decimal number where the number can range from 0 to 999. <b>BCD4</b> 4-digit binary-coded decimal number where the number can range from 0 to 9,999.

**BCD6\***

6-digit binary-coded decimal number stored in two contiguous registers, three digits per register, where the number can range from 0 to 999,999.

**BCD8\***

8-digit binary-coded decimal number stored in two contiguous registers where the number can range from 0 to 99,999,999.

**BIN3**

3-digit decimal number where the number can range from 0 to 999.

**BIN4**

4-digit decimal number where the number can range from 0 to 9,999.

**BIN6\***

6-digit decimal number stored as two 3-digit numbers in two contiguous registers where the number can range from 0 to 999,999.

**BIN8\***

8-digit decimal number stored as two 4-digit numbers in two contiguous registers where the number can range from 0 to 99,999,999.

\*When specifying these data formats, the address specified for *word* defines the first of the two registers in the pair (i.e., the one with the lower reference). This register is assumed to contain the most significant portion of the number.

Note that when sending values to the PLC, the PanelMate unit will delete any high order digits beyond the range allowed.

Also note that BCD and BIN formats do not inherently support negative values.

## PLC Bit References

---

A single format for referencing PLC bits is used throughout the PanelMate template editors. Whenever you need to refer to a specific PLC bit in any expression or control button definition, the following format is required:

[plcnam,bit]

**Note** *plcnam*, is an optional field.

where

plcnam,	The 6-character (or less) name of the designated PLC, as defined in the PLC and Port Parameters Table, followed by a comma. Consult Chapter 23, PLC Name and Port Parameters Table, for more information regarding this name. If this name is omitted, the default PLC name is assumed. (The default PLC is defined in the PLC Names and Port Parameters Editor.) This field is optional.
bit	The actual PLC reference number of the bit to be read or written, using the addressing nomenclature of the PLC defined by the <i>plcnam</i> . Consult the specific PLC section for more information about word reference numbers.



# Chapter 11

## The Main Menu

---

In this chapter, you will learn:

- How to Develop a Configuration
- How to Transfer Information
- How to Perform File Management
- How to Verify a Configuration
- How to Convert a Configuration

# The Main Menu

---

The PanelMate Configuration Software Main Menu contains six selections. The following sections will give a brief description of each selection.

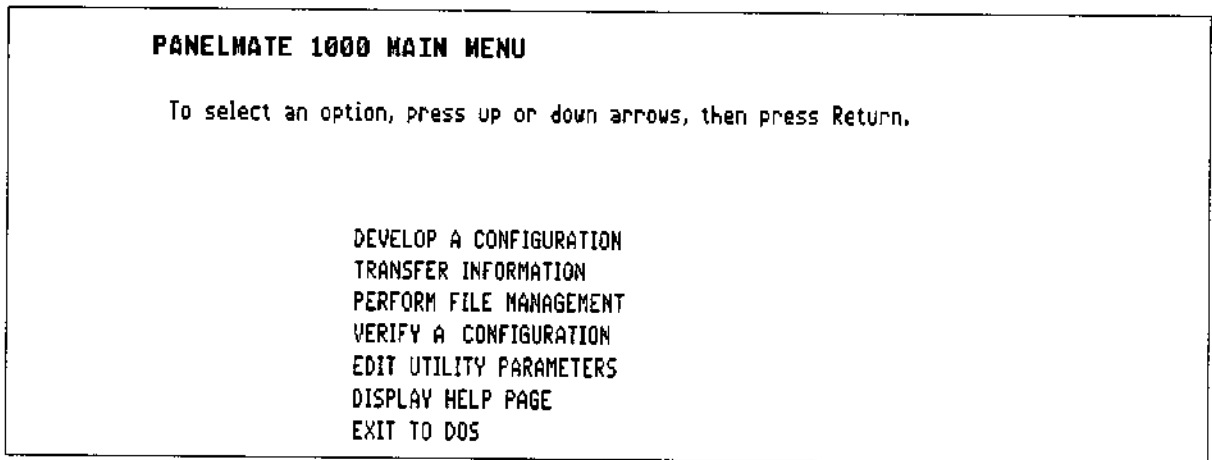


Figure 11-1 Main Menu

## Develop a Configuration

---

This selection allows you to create a configuration for use on a PanelMate system. The configuration will include system parameters, PLC connection information, and display pages containing templates. Information about this selection is found in Chapter 12, The User Configuration Editor.

## Transfer Information

---

This selection allows you to transfer a configuration, driver firmware, or options from the development computer to a PanelMate system. You may also transfer a configuration from an online system and store it on disk on your computer. In addition, you may read the system configuration information from the PanelMate system and display it on the development computer. Information about this selection is found in Chapter 26, Transfer Editor.

## Perform File Management

---

This selection allows you to copy, rename, and delete entire configurations. Information about this selection is found in Chapter 27, File Management.

## Verify a Configuration

This selection allows you to determine if a configuration will fit in the memory of a PanelMate online unit and if all PLC references are valid. Three functions are performed:

- Determine validity of the PLC Name and Port Table
- Run a parsing check of all expressions (i.e., verify all PLC references are valid)
- Estimate the amount of DRAM memory required to run the configuration

After invoking this option, you will be asked to select the DOS filename for the User Configuration you wish to size. Depending upon the size and complexity of the configuration, it may take from 10 seconds to 3 minutes or more to complete this function. A typical screen image is duplicated below.

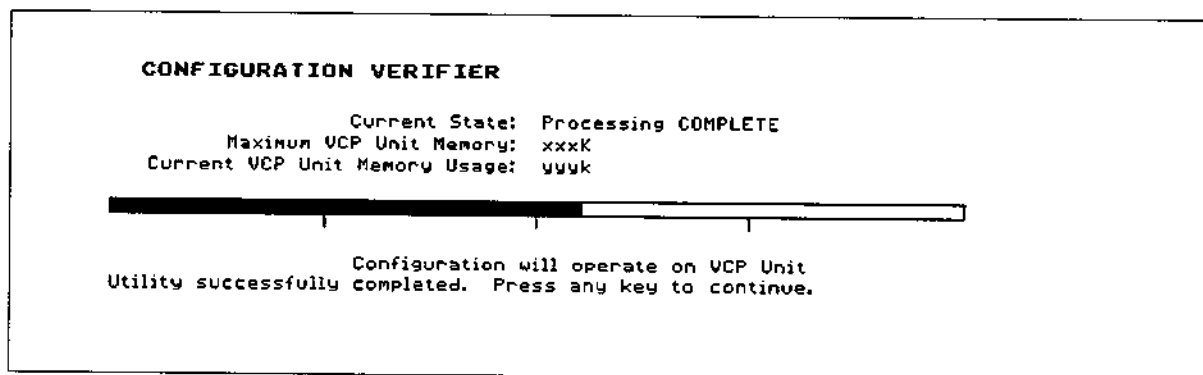


Figure 11-2 Sample Configuration Verifier Screen Display

The current state will update as each individual process is executed. The bar graph display is updated to indicate the memory requirement estimate. If no problems are found, you will receive the following message.

```
Configuration will operate on VCP Unit.
```

```
Utility successfully completed. Press any key to continue.
```

If a problem is found during the parsing check of expressions, error messages will be displayed to indicate where the problems are located. This is a very helpful debugging tool and it is strongly recommended to be executed before attempting to go to Run Mode. It is also recommended that the Configuration Verifier be executed for merged configurations to ensure the validity of the PLC Name and Port Table and all PLC references.

If the configuration is too large, one of two error messages will be displayed. The first message will state the configuration will not operate on the PanelMate unit because it is too large. The other message states the configuration may not operate. Because the Configuration Verifier function approximates memory usage, there is a range of memory calculation which can only be confirmed by actually downloading to the PanelMate unit. If the configuration is too large to operate on the PanelMate unit, you can edit the configuration to better utilize memory.

## Edit Utility Parameters

This selection allows you to set up various operating parameters of the Configuration Software.

### Directory Names (Paths)

The first page of the Utility Parameters Editor contains the DOS directory names and paths for the Configuration Software. The defaults are set to the C:\VCP1000 subdirectories which are the defaults automatically created by the Setup program when the software is installed on your personal computer.

```
UTILITY PARAMETERS EDITOR
F1=          F2=          F3=          F4=          F5=
F6=          F7=MORE     F8=          F9=         F10=EXIT

Directory Names/Paths
  Configuration Directory
  Downloadable Driver Directory
  Character Font Directory
  Temporary Directory
  PanelMate Options Drive

Configurations
  Automatic Save Every
  Automatic Backups
  Display Backups

C:\VCP1000\ONLINE\cfg
C:\VCP1000\ONLINE\driver
C:\VCP1000\ONLINE\font
C:\VCP1000\ONLINE\
A

10 minutes
YES
YES
```

Figure 11-3 Utility Parameters Editor (Page 1)

The default subdirectories shown in figure 11-3 are explained below. Note that these subdirectory names can be changed if desired.

The default Configuration Directory is C:\VCP1000\ONLINE\CFG. The CFG directory contains all the user configuration files which have the extensions .PC0, .BK0, and .SV0.

**Note** You may wish to change the default to a floppy disk drive to keep your files transportable from PC to PC. An example of a valid directory is A:\Screens\.

The default Downloadable Driver Directory is C:\VCP1000\ONLINE\DRIVER. The DRIVER directory contains the various PLC drivers which must be downloaded to the PanelMate unit.

The default Character Font Directory is C:\VCP1000\ONLINE\FONT. The FONT directory contains the character cell representations for the Normal, Graphics, and International Character fonts.

The default Temporary Directory is C:\VCP1000\ONLINE\PC.TMP. The PC.TMP directory is used to store interim saves made during the configuration process before the final save of the user configuration is made. The directory is created at startup and deleted when the software is exited.

**Note** If you wish to use a RAMDISK to improve performance, you must reserve a minimum of 132K of memory for this purpose.

The PanelMate Options Drive defaults to drive A. The Options Drive will be read when an option is being installed on the PanelMate unit.

## **Automatic Saves**

The automatic save feature provides automatic periodic saves of your user configuration to protect against catastrophic personal computer failures such as power outages. The feature can be turned off or set to 10, 20, or 30 minutes. The default value is factory shipped at 10 minutes.

If enabled, this feature automatically creates a save file (.SV0) on a periodic basis. If the Configuration Editor is exited by user command, then the save file is deleted. If the Configuration Editor is exited abnormally (by power failure for example), then a .SV0 file is created which contains the last saved work. This file can be copied to a .PC0 file and then edited.

The save time period is the time from the last save until the Save Routine is armed. When the Save Routine is armed, it requires two conditions to be fulfilled before the save takes place. First, an interim save of a component file of the user configuration must occur. (If nothing has been saved, then the Save Routine will not take place.) If an interim save has occurred, the second condition is that the keyboard must be inactive for 10 seconds before the save will take place. Once the two conditions are met, the Save Routine takes place and the timing period restarts.

## **Automatic Backup**

The Automatic Backups feature when enabled will create a backup file when a user configuration is opened for editing. The default is YES for backups. Although not recommended, the setting can be changed to NO to turn it off and save disk space.

Backup is explained in the following example:

When you start editing, two files exist: File.BK0 (revision 4) and File.PC0 (revision 5).

(Revision refers to the fact that you have modified the file and revised it a number of times.)

Next you open File.PC0 (revision 5) to begin to edit it. As you edit the pages and save them, a file is created in the temporary directory (revision 5+). When you have completed the editing, you perform a Save Configuration. The following sequence of events occur automatically:

- Delete File.BK0 (revision 4)
- Rename File.PC0 (revision 5) to the name File.BK0
- Save the temporary file to File.PC0 (revision 6)

The end result is that there are two files: File.BK0 (revision 5) and File.PC0 (revision 6).

If an error was made during the editing process and stored as revision 6, you can go back to the old revision 5 to begin the editing process over again.

## **Display Backups**

The Display Backups feature will show the backup files when the configuration directory is displayed. The default is set to display the backup files. It can also be de-selected.

The second page of the Utility Parameters Editor can be accessed by pressing <F7> at the first page. This page selects ports on the personal computer (see figure 11-4). The upload/download device selection determines which serial port will be used to upload or download files to the PanelMate unit. Serial Ports 1 through 4 (COM1 through COM4) may be selected if your personal computer has the proper ports. The default is the first serial port available on the personal computer (usually COM1) or NONE if no serial ports exist.

```
UTILITY PARAMETERS EDITOR
F1=          F2=          F3=          F4=          F5=
F6=          F7= MORE     F8=          F9=          F10=EXIT

Upload/Download Device
                Serial Port  COM1

Documentation Device
                Printer Port  LPT1
```

Figure 11-4 Utility Parameters Editor (Page 2)

The documentation device selection defines the printer port on the personal computer. The printer can be used to print documentation of the configuration. One port must be selected from the choices of Parallel Ports 1 through 3 (LPT1 through LPT3), Serial Ports 1 through 4, and User Specified File (File). The default is the first parallel port available on the personal computer (usually LPT1). If no parallel ports exist, then the default is the first COM port available (usually COM1). If no serial ports exist, then the default is NONE. If a serial port is selected (COM1 through COM4), you must configure the Baud Rate, Data Bits, Stop Bits, and Parity for the port. (The default for the COM port is 9600, 8, 1, and None.) If File is selected, a new Documentation Directory field is displayed for you to enter the directory for your file. The default directory (C:\VCP\ONLINE\print) is created when the Configuration Software is installed.

**Note** When File is selected and Print Documentation is selected from the Configuration Editor Menu, a screen will appear so you may specify the print documentation filename before you enter the Documentation Menu. Refer to Chapter 25, Print Documentation, for more information.

Press <F7> to toggle between pages. Press <F10> to exit the Utility Parameters Editor.

## Display Help Page

---

This selection will display a page which explains how you select help pages in the software. When help is available, HELP will appear in the top right corner of the screen. Press <Alt><F1> to access the help page. To exit a help page press <F10>.

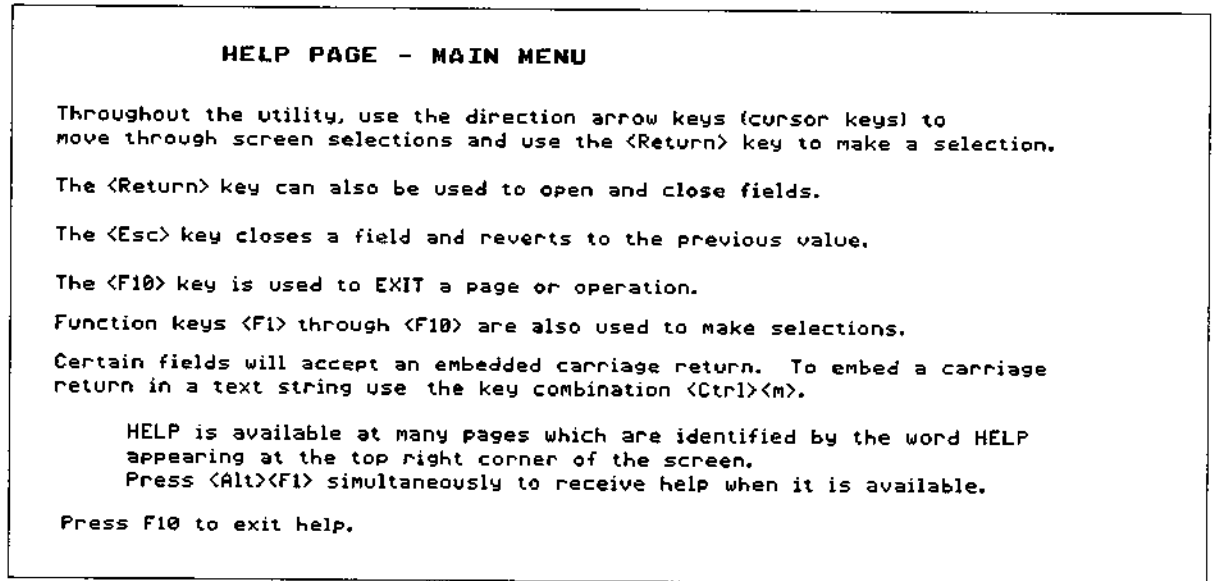


Figure 11-5 Help Page

## Exit to Dos

---

This selection will allow you to exit from the Configuration Software and return to the DOS operating system.



# Chapter 12

## The User Configuration Editor

---

In this chapter, you will learn:

- How to begin creating a new user configuration
- How to edit an existing user configuration
- How to display a configuration
- How to select international fonts
- How to merge configurations

# The Develop Configuration Menu

---

The Develop Configuration menu contains three selections:

## Edit an Existing Configuration

This selection allows you to edit a configuration previously saved on the hard disk of the DOS-based computer. The configuration will include system parameters, PLC connection information, and display pages.

## Create a New Configuration

This selection allows you to create a new configuration that did not exist before. You may use an existing configuration as the basis for the new one.

## Return to Main Menu

This allows you to return to the Configuration Software Main Menu.

Use the up and down arrows to highlight the desired utility section and then press <Return>. The selections are explained in the following pages.

## Edit an Existing Configuration

---

This section allows you to edit a configuration previously saved on the hard disk. The configuration will include system parameters, PLC connection information, and display pages.

After choosing this option, the software will display a list of the configuration files presently on the hard disk in the Configuration Directory entered in the Utility Parameters Editor. You may select a file name by typing it (including extension) and pressing <Return>. You may also press the <F1> key which will highlight a name in the displayed list. With this method, use the arrow keys to move the cursor to the desired name and press <Return> to select it. Selecting a name by either method will place you in the Configuration Editor.

The filename extension for configurations for the PanelMate Series 1000 is .PC0.

The Configuration Software package can also be configured to perform Automatic Saves and Automatic Backups. See the Edit Utility Parameters section in Chapter 11 for a detailed explanation. If these features are selected, then backup files with the extension, .BK0, and save files with the extension, .SV0, may be created. Configurations are automatically saved when the Autosave feature has been enabled.

If you are entering a filename and wish to exit this editor, press <Esc> to close the field, then press <F10> to exit. If you are selecting a filename and using the arrow key to select a filename, press the <F1> key labeled "Entry". If the filename field is open, press <Esc> to close the field, then press <F10> to exit.

## Create a New Configuration

This section allows you to create a new configuration that did not exist before. The configuration will include system parameters, PLC connection information, and display pages.

After choosing this option, the page screen will display the prompt:

Do you want to use an existing configuration as a base  
for this configuration? Press Y or N.

You may use a configuration already stored on the hard disk as the basis for the new configuration you will create. After making changes or additions to the configuration, you will save it under a new name of your choice.

If you answer the prompt with a "Y", the software will display a list of the configuration files presently on the hard disk. You may select a filename by typing it (including extension) and pressing <Return>. You may also press the <F1> key which will highlight a name in the displayed list. With this method, use the arrow keys to move the cursor to a desired name and press <Return> to select it.

Refer to the previous section, Edit an Existing Configuration, for information on filename extensions, automatic saves, and automatic backup files.

If you answer the prompt with an "N", the software will display an Initialized Configuration Option screen like the following:

INITIALIZED CONFIGURATION OPTION				
F1=CONFIG	F2=	F3=	F4=	F5=
F6=	F7=	F8=	F9=	F10=EXIT
DH-485 Option:		<input type="text" value="NO"/>		
Modicon MODBUS Option:		<input type="text" value="NO"/>		
Configuration Name: FILE1				
Do not include the file extension.				
Directory: C:\VCP1000\ONLINE\cfg				
FILE1.PC0	FILE2.PC0	FILE3.PC0	FILE4.PC0	FILE5.PC0

Figure 12-1 Initialized Configuration Option

This screen is used to name the configuration and to set up the optional features which will be available in the configuration. To enable a feature, use the arrow keys to highlight the DH-485 option or Modicon Modbus option, then press <Return>. A menu will appear to allow feature selection. Use the arrow keys again to highlight your choice, then press <Return>.

**Note** If a configuration is created containing an optional feature, that feature must be available in the PanelMate online system which receives and executes the configuration.

After setting up optional features, enter the name of the new configuration. To do this, highlight the Configuration Name field. Press <Return> and enter the name (no extension), then press <Return> again to close the field.

#### Enter Configuration Editor

When all information regarding optional features and configuration name is correct, press <F1> to enter the Configuration Editor.

## The Configuration Editor Menu

---

After deciding whether you will edit a new or an existing configuration, the software will display the Configuration Editor menu which contains the following options:

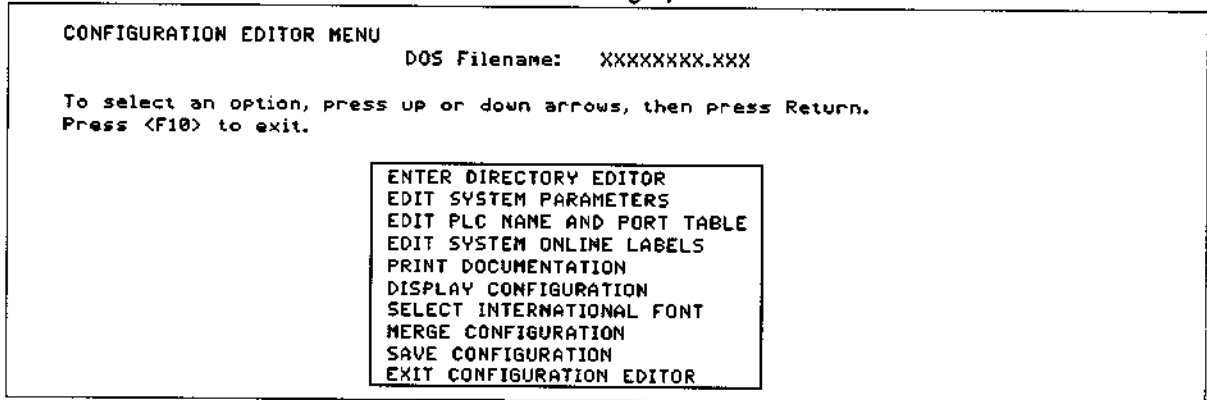


Figure 12-2 Configuration Editor Menu

#### Enter Directory Editor

This selection allows you to select display pages for editing. You may also copy, swap, move, and assign password or keyswitch protection to pages. Information about this selection is found in Chapter 13, Directory Editor.

#### Edit System Parameters

This selection allows you to edit general system parameters used during the online system's Run Mode. Information about this selection is found in Chapter 22, Defining System Parameters.

#### Edit PLC Name and Port Table

This selection allows you to set communication port parameters, PLC device names and ID numbers, and Allen Bradley DH-485 parameters. Information about this selection is found in Chapter 23, PLC Name and Port Parameters Table.

#### Edit System Online Labels

This selection allows you to change the labels which appear during the online system's Run Mode. Information about this selection is found in Chapter 24, System Online Labels Editor.

#### Print Documentation

This selection allows you to send documentation of the configuration to a printer connected to the computer. Information about this selection is found in Chapter 25, Print Documentation.

## Display Configuration

This selection allows you to list all the possible component files in the configuration, which files presently exist, sizes of the files, all display page titles, and the amount of free configuration memory remaining.

## Select International Font

This selection allows you to select 10 additional characters within the Normal font containing international characters.

## Merge Configuration

This selection allows you to merge parts of other configuration files to the configuration which is currently being edited or created.

## Save Configuration

This selection allows you to save the configuration to disk on the DOS-based computer. You will be prompted for a DOS filename for your configuration. The default name is the name selected when the Configuration Editor was first entered.

## Exit Configuration Editor

This selection prompts you to save the configuration before returning to the Develop Configuration Menu.

## Display Configuration

This selection will show the component file sizes for the configuration which is currently being edited. Press <F10> to exit and return to the Configuration Editor Menu. If a backup file (.BK0) is downloaded, the Display Configuration Menu will display the file extension as .PC0.

DISPLAY CONFIGURATION				
F1=	F2=	F3=	F4=	F5=
F6=	F7=	F8=	F9=	F10=EXIT
Name: DISPLAY.PC0	Product: PanelMate 1000			
Version: X.XX	Free Memory: 19257			
Options:				
Name	Size	Name	Size	Page Title
*System Parameters	96	*Page 00	210	Page Title 0
*PLC Name and Port	321	*Page 01	1358	Page Title 1
*Message Library	522	*Page 02	1358	Page Title 2
*Page Titles	55	*Page 03	210	Page Title 3
System Labels	0	Page 04	0	Page Title 4
Normal Font	0	Page 05	0	Page Title 5
		Page 06	0	Page Title 6
		Page 07	0	Page Title 7

Figure 12-3 Display Configuration Menu

**Note** If a previous version configuration is read into the current Configuration Software and you enter the Display Configuration screen, the proper version is displayed. If an autosave occurs, the version is changed to the current Configuration Software version.

## Select International Font

---

This selection allows you to choose an International Font from a menu. The International Font is chosen by entering the DOS filename for the font, such as French1 or German1. Once selected, a help page with a sample of the font automatically displays on a VGA system. An International Font adds 10 additional characters to the Normal Font. Typically, these characters are the unique characters of a language (such as vowel forms). By typing the appropriate recall key, an international character cell can be placed anywhere a Normal Font character may be displayed. See Appendix E for International Font Character details concerning the character cell representations for the fonts.

Due to the way an International Font is loaded into the PanelMate unit, only one font can be loaded into the Driver Firmware into the PanelMate unit. If a different International Font is required, the Driver Firmware must be re-downloaded into the PanelMate unit and a configuration with the new International Font must be downloaded.

This feature is designed to permit the online display of international languages. This feature is available on all units. Due to the lack of printer standards, it is not possible to print out the redefined character cells. This impacts print documentation where the character cells are replaced by spaces.

On a VGA system, the <Alt> <F2> keys will display the help page for International and Line Characters in most editors.

## Merge Configuration

---

This editor will allow you to merge parts of other configuration files to the configuration which is currently being edited or created. The current configuration will be the destination file of the merge.

After selecting Merge Configuration, the Source Configuration Name Entry screen is displayed. The software will display a list of the configuration files where the path is determined by the Utility Parameters Editor. The default path is the CFG (configuration) directory. You may select a filename by typing it (including the extension) and pressing <Return>. You may also press the <F1> key which will highlight a name in the displayed list. With this method, use the arrow keys to move the cursor to a desired name and press <Return>. The configuration selected at this point will be the source configuration of the merge.

An alert window is displayed when a source configuration does not have the same options as the destination file. This information may be viewed by pressing <F6>=ALERT.

```

MERGE CONFIGURATION EDITOR
F1=          F2=          F3=          F4=          F5=
F6=          F7=          F8=CUR CFG  F9=          F10=EXIT

Use arrow and RETURN keys to select component file to merge.

                Source Configuration Name: XXXXXXXX.PC0  Version: X.XX

Name           Size      Name           Size      Page Title
System Parameters    96      Page 00        210      Page Title 0
PLC Name and Port   321      Page 01       1358      Page Title 1
Message Library     522      Page 02       1358      Page Title 2
Page Titles         55      Page 03        210      Page Title 3
System Labels        0      Page 04         0        Page Title 4
Normal Font          0      Page 05         0        Page Title 5

```

**Figure 12-4 Merge Configuration Editor Menu**

Within the Merge Configuration Editor, the source configuration file to be merged is displayed. The cursor may be used to highlight an area for merging. Each component file is merged independently. Component files which are listed but cannot be selected are not available for merging.

An area is selected by using the arrow keys to highlight the desired field and pressing <Return>.

**Note** It is recommended that the Configuration Verifier for Run Mode be executed for merged configurations to ensure the validity of the PLC Name and Port Table and all PLC references.

### System Parameters

After System Parameters has been selected, press <Return> to close the field and the System Parameters component file will be transferred. If the destination configuration already contains System Parameters, a message will appear notifying you and will ask if you want to overwrite this information. Press <Y> to overwrite the file or <N> to cancel the copy.

### PLC Name and Port Table

After the PLC Name and Port Table has been selected, press <Return> to close the field and the PLC Name and Port Table component file will be transferred. If the destination configuration already contains PLC Name and Port Table information, a message will appear notifying you and will ask if you want to overwrite this information. Press <Y> to overwrite the file or <N> to cancel the copy.

## Message Library

After the Message Library has been selected, the following prompt is displayed: "Do you want to completely overwrite the file? Press <Y> to overwrite, <C> to continue and merge some messages or <N> to abort." Press <Y> to completely overwrite the destination message library or <N> to cancel the copy. If <C> is pressed, complete the following:

1. The next prompt is: "Enter the first message number to merge: \_\_\_." This should be a numeric value between 1 and 100 for a PanelMate Series 1000.
2. Once the first source message number has been entered, press <Return> to close the field.
3. The next prompt reads: "Source messages are from xxx to message number: \_\_\_." Enter the last message number in the range to be merged, a numeric value between 1 and 100 for a PanelMate Series 1000.
4. The next prompt reads: "Source messages from xxx to xxx will be merged starting at destination message: \_\_\_." Enter the first message number for the destination of the messages to be merged.
5. Press <Return> to close the field and the messages will be transferred to the destination message library file.

## Page Titles

After Page Titles has been selected, press <Return> to close the field and the Page Titles will be transferred. If the destination configuration already contains Page Title information, a message will appear notifying you and will ask if you want to overwrite this information. Press <Y> to overwrite the file or <N> to cancel the copy.

Merging a page title does not automatically change the user configured page number. After merging, verify that the page title and page number is correct.

## System Labels

After the System Labels has been selected, press <Return> to close the field and the System Labels component file will be transferred. If the destination configuration already contains System Label information, a message will appear notifying you and will ask if you want to overwrite this information. Press <Y> to overwrite the file or <N> to cancel the copy.

## Normal Font

After the Normal font has been selected, press <Return> to close the field and the Normal font will be transferred. If the destination configuration already contains a Normal font, a message will appear notifying you and will ask if you want to overwrite this information. Press <Y> to overwrite the file or <N> to cancel the copy.

## Pages

After a page has been selected, the prompt "Enter the destination page number:" is displayed.

1. Enter a numeric value (0-7) for a 8 page configuration.
2. Once the destination page number has been entered, press <Return> to close the field and the page will be transferred.
3. If the destination page already contains information, a message will appear notifying you and will ask if you want to overwrite this information. Press <Y> to overwrite the file or <N> to cancel the copy.
4. Merging a page does not automatically change the user configured page number. After merging, verify that the page title and page number is correct.

## Current Configuration <F8>

This will display the destination file information. This information will include the configuration name, version, component file size, and the amount of free memory. Pressing <F8> will toggle between the Current Configuration screen and the Last Status screen. To return to the Merge Configuration Editor, press <F10>.

```
MERGE CONFIGURATION EDITOR - CURRENT CONFIGURATION DISPLAY
F1=          F2=          F3=          F4=          F5=
F6=          F7=          F8=STATUS   F9=          F10=EXIT

                Current Configuration Name: XXXXXXXX.PC0  Version: X.XX

Name           Size      Name      Size      Page Title
System Parameters    96      Page 0     210      Page Title 0
PLC Name and Port   321      Page 1    1358      Page Title 1
Message Library     522      Page 2    1358      Page Title 2
Page Titles         55      Page 3     210      Page Title 3
System Labels        0       Page 4        0      Page Title 4
Normal Font          0       Page 5        0      Page Title 5

Free Memory: XXXXXX
```

Figure 12-6 Merge Configuration Editor - Current Configuration Display

## Current Configuration Last Status

Selecting F8=STATUS from the Current Configuration menu will display the destination file information including the component file status origins after the last save. From this editor, the cursor is not available and the F8=CUR CFG. Pressing <F8> will toggle between the Last Status screen and the Current Configuration screen.

```
MERGE CONFIGURATION EDITOR - CURRENT CONFIGURATION LAST STATUS
F1=          F2=          F3=          F4=          F5=
F6=          F7=          F8=CUR CFG  F9=          F10=

                Current Configuration Name: XXXXXXXX.PC0  Version: X.XX

Name                Last Status                Name                Last Status
* System Parameters ORIGINAL                    * Page 00           ORIGINAL - PXX
* PLC Name and Port ORIGINAL                    * Page 01           ORIGINAL - PXX
* Message Library   ORIGINAL                    * Page 02           USER MODIFIED - PXX
* Page Titles       MERGED TITLE                * Page 03           COPIED - filename (PXX)
* System Labels     ORIGINAL                    * Page 04           USER MODIFIED - PXX
Normal Font
```

Figure 12-7 Merge Configuration Editor - Current Configuration Display Last File Status

Status codes:

ORIGINAL	The component file has not changed or been entered since the file has been called into memory.
USER MODIFIED	The component file has been saved since initial entry into the merge editor.
COPIED	The component file has been merged from the source file.
MERGED	The Message component files have been integrated. The files have not been completely overwritten.
MERGED TITLE	The Page Title component file will display this status after a page has been merged into the source configuration.

**Note** If the Autosave feature is enabled, the component file status will be updated to ORIGINAL.

# Chapter 13

## Directory Editor

---

In this chapter, you will learn:

- How to begin page configuration
- How to title pages
- How to enter the Page Editor
- How to check the amount of remaining memory

## Before You Start Configuring Pages

---

As soon as you begin configuring pages, you will need to begin referencing PLC words and bits. For maximum efficiency, you should review the Word and Bit References section in Chapter 10 to become familiar with the way the PanelMate unit expects you to enter these word and bit references.

You should have already used the PLC Name and Port Editor to define PLC names, the types of PLCs you will be using with this unit, the communication parameters for each port, the default PLC, and format information if you are planning to use the Generic Protocol.

Refer to Chapter 23 for information on the PLC Name and Port Editor.

## Functions of the Directory Editor

---

The Directory Editor is used to:

1. place titles on pages
2. access the Page Editor
3. edit titles on pages
4. re-order the pages by swapping them or moving them
5. delete entire pages
6. copy entire pages
7. see which pages are still blank
8. check the amount of free memory
9. select password protection for a page

**Note** The two fields on the Directory Editor, Page No. and Page Title, are used to perform very different tasks, so it is important to note their functions as you read the instructions. Use the Page No. field to make changes that affect entire PAGES: deleting, copying, and re-ordering. The Page Title field changes JUST THE PAGE TITLE.

The pages are fully defined using the Page Editor which is explained in Chapter 14.

# Enter Directory Editor

This editor allows you to select display pages for editing. You may also copy, swap, move, and assign password or keyswitch protection to pages. After making this selection from the Configuration Editor menu, the Directory Editor will be displayed. It looks like the following figure.

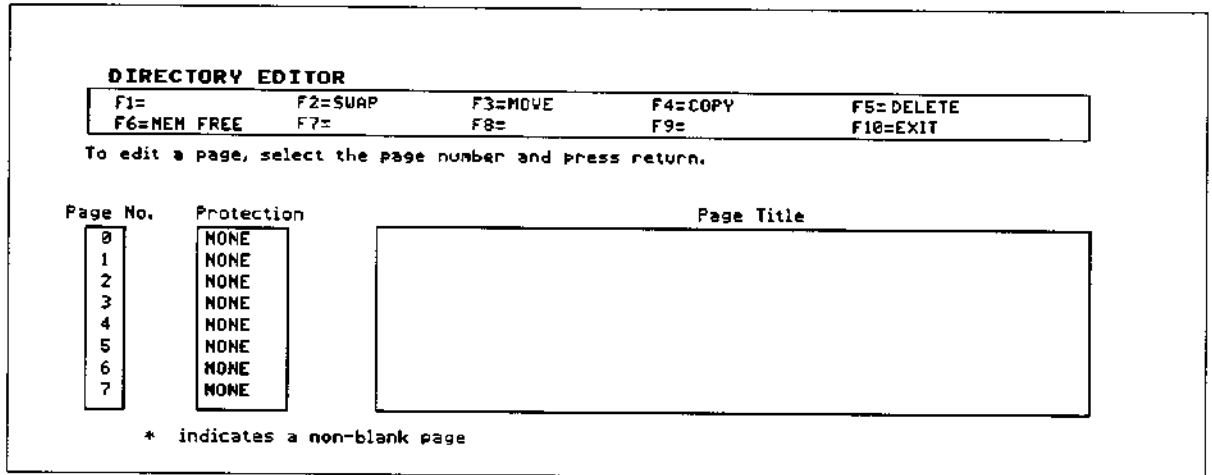


Figure 13-1 Directory Editor

## Access the Page Editor

You will want to go to the Page Editor when you want to create or edit pages and add or modify any templates. To access the Page Editor, use the cursor arrow keys to select a page number in the Page No. field, then press <Return>.

## Protection

The Protection fields can require the operator to use a password before a page can be called to the screen during Run Mode. There are two software passwords. Any combination of these two items may be used to protect access to a page. To set page protection, use the arrow keys to highlight the correct field. Press <Return> and the Page Password Protection menu will display all the available combinations. Use the arrow keys to highlight your choice, then press <Return> again. See Chapter 22, Defining System Parameters, for more information.

## **Page Title**

---

The Page Title fields allow you to assign each page a unique title. This name will be displayed at the top of the page when it is called in Run Mode. To enter or change a page title, use the arrow keys to highlight the correct Page Title field. Press <Return> and enter the name you have chosen for that page, then press <Return> to close the field.

The PanelMate unit will automatically place the title on the correct page. You can verify this by looking at the page in the Page Editor. Note that the page number is not displayed on the Page Title automatically in Run Mode. If you want the page number displayed, you must include it as part of the page title.

### **Edit Existing Titles**

Any title can be edited at any time using the following procedure:

- Select the Page Title to be edited (use cursor arrow keys to step through Page # and Page Title fields).
- Press <Return> to enter the edit mode.
- Use the left and right arrow keys to move the cursor over characters without erasing them.
- Type over any characters to change them.
- Press <Backspace> or <Del> to erase characters.
- Press <Ins> to enter the insert mode, which will allow you to insert characters at the position of the cursor. Press <Ins> again to get out of the insert mode.
- Press <Return> to close the field or press <Esc> to restore the previous title

To delete a title and start again:

1. Select the Page Title to be deleted, using the cursor arrow keys.
2. Press <F5> to delete the title.
3. Press <F5> again in response to the prompt that appears at the top of the screen.
4. You are now ready to place a new title in the field.

## **Swap**

---

You may swap the location of two non-blank pages with the <F2> key. Use the arrow keys to highlight the page number of the first page you want to swap, then press <F2>. Now use the arrow keys to highlight the second page number, and press <F2> again.

## **Move**

---

You may move a page and its contents, including its title, to a different (unused) page number with the <F3> key. Use the arrow keys to highlight the page number of the page you want to move, then press <F3>. Now use the arrow keys to highlight the new page number, and press <F3> again.

## **Copy**

---

You may copy a page and its contents to a new (unused) page number with the <F4> key. This may be useful when you need to create a page that is very similar to one which already exists. It may be quicker to first copy an existing page and then make changes to it, rather than configuring a new page. Use the arrow keys to highlight the page number of the page you want to copy, then press <F4>. Now use the arrow keys to highlight the new page number, and press <F4> again.

## **Delete**

---

You may delete a page and its contents with the <F5> key. Use the arrow keys to highlight the page number of the page you want to delete, then press <F5>. To prevent any accidental deletion, the editor will ask you to press <F5> again as a confirmation. At a final prompt, the editor will give you one more chance to avoid deleting the page. Press <Y> if you are sure you want to delete the entire page.

## **Memory Free**

---

The PanelMate unit has 16K of configuration memory. The <F6> key allows you to determine how much free configuration memory is available. Configurations with many pages or many templates per page will use more memory than those with few pages or templates. After you press <F6>, the amount of free memory will be displayed at the top of the screen. Note that it is possible to create dense pages that can use up the available memory before the total number of pages have been configured.

In order to determine if the configuration will run online, you should also use the Configuration Verifier for Run Mode Utility. This will determine if there is enough DRAM memory to support the run time communication routines automatically created by the software that will be required when online. It will also check all expressions for validity. To run the Configuration Verifier for Run Mode, save your configuration and return to the Main Menu. Refer to the Configuration Verifier for Run Mode section in Chapter 11 for more information.

## **Exit**

---

You may exit the Directory Editor and return to the Configuration Editor menu with the <F10> key.



# Chapter 14

## Page Editor

---

In this chapter, you will learn:

- Page layout
- How to add templates to a page
- The purpose of the Display Editor

# Configuring the PanelMate unit

The Page Editor is used to configure and edit the pages that will be used online. The Page Editor is accessed by selecting a page from the Directory Editor. Upon entering the Page Editor, you must select one of two editing modes: Template or Message Library.

The PanelMate unit uses templates to present information to the operator, thus providing a proven, standard method of presentation. The graphical user interface (GUI) standard can be used on every online unit. Templates are configured by using fill-in-the-blank spreadsheets. The Template Mode provides access to the following editors:

- Indicator Template Editor
- Readout Template Editor
- Bar Template Editor
- Display Template Editor
- Table Template Editor
- Maintenance Template Editor

The Message Library Editor is used to enter messages that appear in the Display Templates.

## Page Layout

All active pages in Run Mode have the same basic layout. The page title, created in the Directory Editor, is on the top line of the page. This first line contains the page title, configured page indications, and password status indications. The Page Layout will appear as shown in figure 14-1.

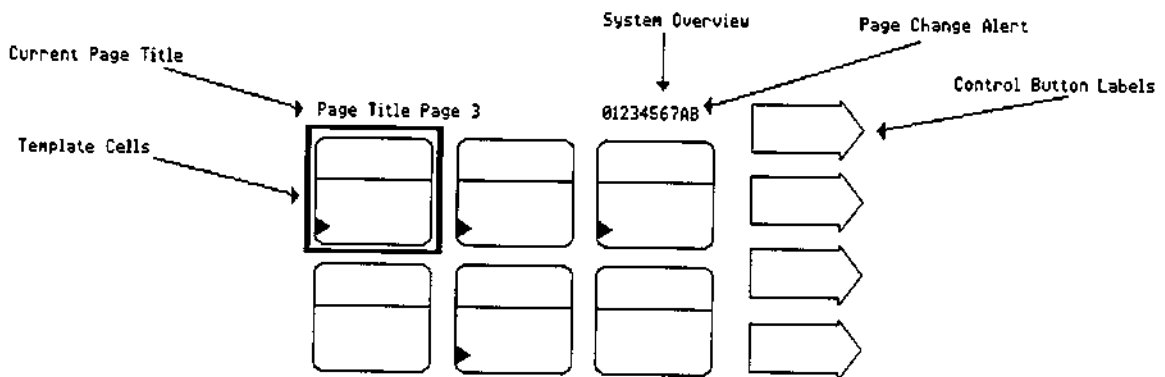


Figure 14-1 PanelMate Series 1000 Page Layout

One-fourth of the screen, located at the far right, is reserved for labels for the Control Buttons. You can define Control Button usage in the definitions of each type of template. Each template can be associated with as many as four Control Buttons.

To view a template's Control Button labels, select that template with the cursor while in the Page Editor and press <F1>.

Note that templates with associated control functions will have a small arrow placed in the lower left corner of the template.

The remainder of the screen is divided into six cells. A normal-size Indicator or Readout Template is the size of one cell. Therefore, it is possible to place up to six templates on a single page. However, the smallest Bar Template covers two horizontal cells and the smallest Display Template covers two horizontal cells. Table Templates range from 1 to 2 vertical cells tall and 2 to 3 horizontal cells wide. Keep these requirements in mind when planning the arrangement of templates on a page. Templates may not overlap.

## Page Editor Main Menu

---

When the page editor is first entered, the following menu is displayed. An explanation of each item is contained in the following sections.

F1=TEMPLATE	F2=	F3=MESSAGE	F4=	F5=
F6=	F7=	F8=	F9=SAVE	F10=EXIT

Figure 14-2 Page Editor Main Menu

## Page Editor in Template Mode

---

The Page Editor in the Template Mode is used to:

1. place new templates on a page (indicator, readout, bar, display, table, and maintenance templates)
2. access the Template Editors to define the templates
3. move templates from cell to cell on the same page
4. copy templates to another cell on the same page
5. delete templates from a page
6. copy templates from page to page
7. save a page in memory

Press <F1> to enter the Template Mode of the Page Editor. Within the Template Mode, the following menu is displayed. The operation of each item is reviewed in the following sections.

F1=EDIT	F2=ADD	F3=MOVE	F4=COPY	F5=DELETE
F6=	F7=MEMORIZE	F8=RECALL	F9=SAVE	F10=EXIT

Figure 14-3 Template Mode Menu

## **Edit a Template Definition <F1>**

---

To make a change or addition to an existing template that you have already defined, use the following procedure:

1. Select the template to be edited by using the arrow keys.
2. Press <F1> to edit the selected template. You will enter the Template Editor spreadsheet which will show the template you have selected. Refer to the appropriate Template Editor (Chapters 15 through 20) for information on how to make changes to the template's definition.
3. Press <F10> to return to the Page Editor.

## **Add a Template <F2>**

---

To add a new template to a page:

1. Select an empty cell by using the arrow keys to move the cell cursor. Be sure to select a cell that can accommodate the size of template you plan to use. The selected cell is always the leftmost or topmost cell of a template.
2. Press <F2> to add a new template.
3. Select the type of template you wish to add by pressing <1>, <2>, <3>, <4>, <5>, or <6> for Indicator, Readout, Bar, Display, Table, and Maintenance templates, respectively. You will move immediately to the proper Template Editor which will show the template you have selected. Refer to the appropriate Template Editor for information on how to create the template's definition.
4. Press <F10> to return to the Page Editor.

## **Move a Template <F3>**

---

Once a template has been placed on a page, it can be moved to any empty cell on the page by using the move function:

1. Select the template to be moved, using the arrow keys.
2. Press <F3>.
3. Select the new location for the template. Be sure the area you have selected is large enough to accommodate the template. Remember that the cell you select will be the leftmost or topmost cell of the template.
4. Press <F3> again.

**Note** The new location for a template must be completely blank. Therefore, the move function cannot be used to move a Bar Template up or down, nor can it be used to move a Display Template from side to side. Use <F7> to memorize, <F5> to delete and <F8> to recall for these types of moves. The move function also has limitations with the Table Template.

## **Copy a Template <F4>**

---

If a number of similar templates are to be used on the same page, it may be easier to fully define the first template, copy it as many times as needed, and then edit the definitions of the copies.

To copy a template:

1. Select the template to be copied, using the arrow keys.
2. Press <F4>.
3. Select the location for the copy. Be sure the area you have selected is large enough to accommodate the template. Remember that the cell you select will be the leftmost or topmost cell of the template.
4. Press <F4> again.
5. To edit the definition of this template, press <F1>.
6. To make another copy of the same template, start at step 1 again.

**Note** This function does not keep the copy in memory. Therefore, to copy the same template repeatedly, you must go through the entire copy procedure each time or use the memorize/recall functions.

## **Delete a Template <F5>**

---

When a template is deleted from a page, the entire definition is also deleted. To delete a template:

1. Select the template to be deleted, using the arrow keys.
2. Press <F5>.
3. Because this command is irreversible, a prompt will tell you to press <F5> again if you wish to delete the template. Press <F5> again to delete.
4. Another prompt will appear, asking if you are sure. Press <Y>.

## **Memorize <F7>/Recall <F8> Template**

---

The memorize/recall functions can be used to copy templates from one page to another or to copy a template several times onto the same page. In both cases, the template and its full definition are copied. Therefore, for most efficient use of these functions, fully define the first template, recall it as many times as needed, and then edit the definitions of the copies.

To copy templates using the memorize/recall functions:

1. Select the template to be copied, using the arrow keys.
2. Press <F7> and a prompt will appear at the top of the screen to memorize the template in long term memory.
3. Press <F7> again.
4. Select the new location for this template. This can be done by using the arrow keys to select a cell on the same page, or by exiting the page you are on (press <F10>), selecting a new page, and then selecting the new location on the new page.
5. Press <F8> to recall this template and place the memorized copy in the new location. Because this template remains in memory, more copies can be made by selecting new locations and pressing <F8> as many times as needed.

The template in memory will remain in memory until a new template is placed there or the Directory Editor is exited.

As a reminder, be sure to select a cell that can accommodate the size of template you are copying. The selected cell is always the leftmost or topmost cell of a template.

## **Save <F9>**

---

As you edit a page, all of your work is in a memory file that will be cleared when you exit the Page Editor. You must save your work to move it into a file.

To save your page and store the information in a DOS file, press <F9>.

A page may be saved at any time, but be sure to save before you exit the Page Editor. If you exit without saving, your new work on the page will be lost.

## **Exit the Template Mode <F10>**

---

To exit the Template Mode and return to the Page Editor, press <F10>.

## **Page Editor in the Message Mode**

---

This editor is used to create and edit the text used in the Display Templates. See Chapter 19, Message Library Editor, for more information.

## **Save the Page**

---

This function saves the page to the temporary DOS file.

## **Exit the Page Editor**

---

Press <F10> to exit the Page Editor. This function permits exit back to the Directory Editor with options of either saving or not saving the current page.



# Chapter 15

## Indicator Template Editor

---

In this chapter, you will learn:

- How Indicator Templates are used
- How to define an Indicator Template
- How to edit existing Indicator Templates
- How to return to the Page Editor

# Functions of Indicator Templates

Indicator Templates are designed to be used as the lights and buttons on a control panel are used to indicate the status of devices and to control them, e.g., by turning them on or off.

This single editor is used to define all the characteristics of an Indicator Template including its visual attributes, status messages, alarm conditions, and all control functions. The following section describes how each field in this editor relates to the template, and what the appropriate field entries might be. Refer to the figure below as needed.

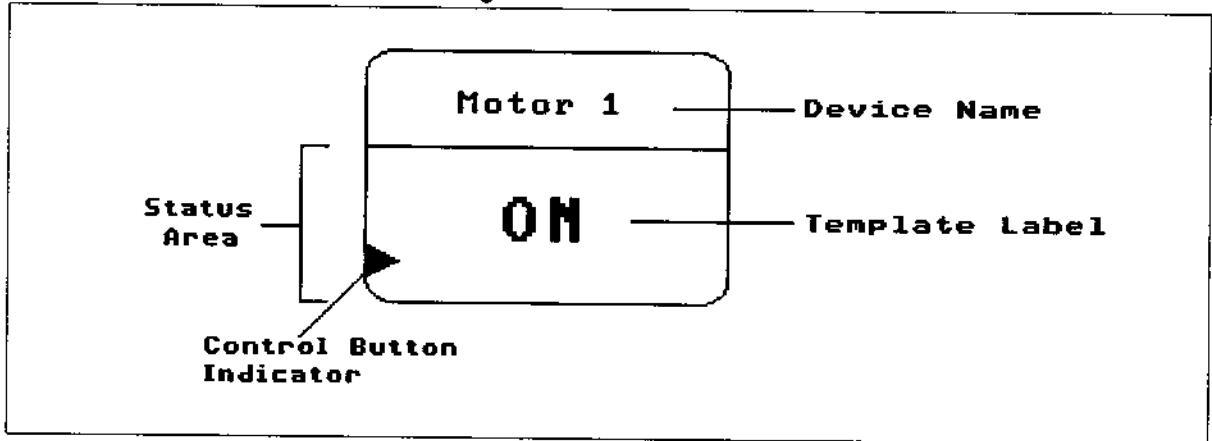


Figure 15-1 Indicator Template

The following figure shows a representation of the Indicator Template Editor. Each of the fields which compose this spreadsheet is reviewed in the following sections.

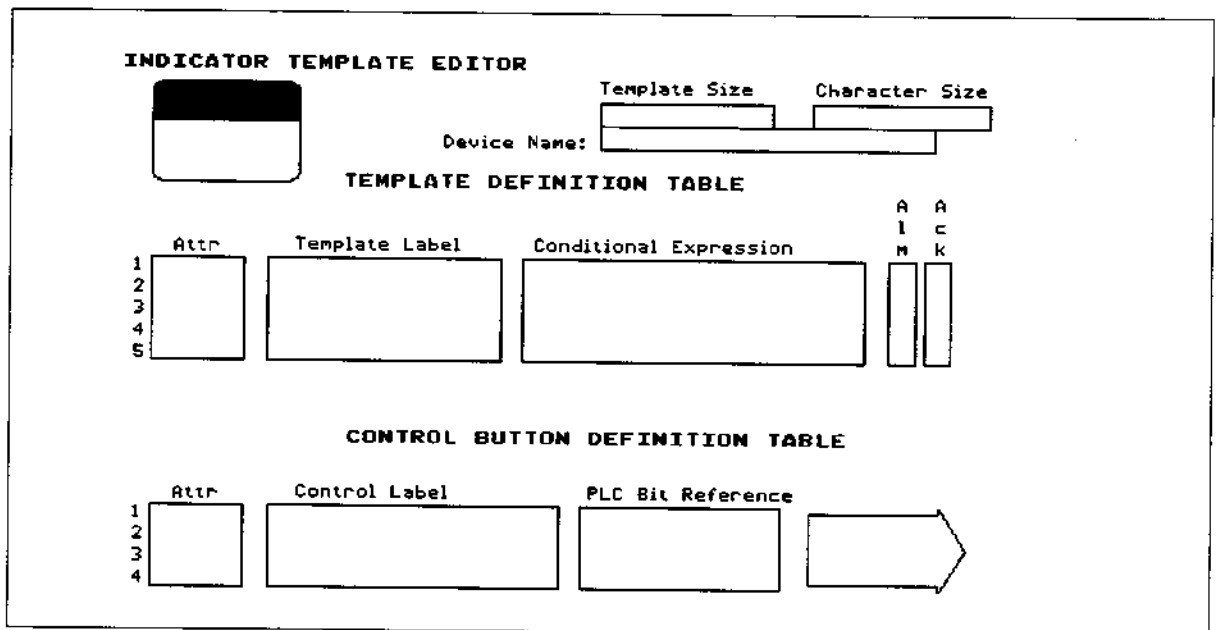


Figure 15-2 Indicator Template Editor

To edit a text field, cursor to the field and press <Return> to open the field. Type the text. Press <Return> to close the field or <Esc> to revert to the old value.

Other fields have Option Windows which pop-up on the screen. To edit this type of field, cursor to the field and press <Return>. Use the cursor keys to scroll through and highlight your selection. Press <Return> to accept the change or <Esc> to revert to the previous value.

Option Windows display all possible choices and will cursor over selections which are not permissible choices based upon your current configuration.

To exit the Indicator Template Editor page, press <F10>.

## **Template Size**

---

The selections available are NORMAL or DOUBLE-WIDE. Remember that for placing the template on the page, the cell cursor is always the left cell of a double-wide template.

## **Character Size**

---

This field defines the size of the characters used in the status area of the template. The device name area of the template always consists of normal-size characters. The selections available are NORMAL, QUAD, or DOUBLE-HIGH. For maximum readability, select the largest size that will fit in the template.

## **Device Name**

---

This field accepts 16 normal-size characters in 2 lines. Only normal-size characters are used in this field. If you wish to center the device name, use <Ctrl> <m> to insert a carriage return and the space bar to add spaces.

## **Template Definition Table**

---

In the Template Definition Table, there are five lines that can be filled in to define various states of the device. These five lines have their priorities established so that line 1 has the highest priority and line 5 has the lowest priority. This means that if two lines have conditional values that solve to true, the configuration of the line with the highest priority will be displayed in the template.

During configuration, line 5 will be displayed on the page as a default. Consequently, if you define a template and leave line 5 blank, which is a perfectly acceptable thing to do, the template appearing in the Page Editor will be "blank".

### **Attr (Character Attributes)**

This field allows you to select the display attributes of the control button. The selections available are NORM (normal, black letters on white background), REVR (reverse, white letters on black background), and BLINK (blink, alternating between normal and reverse). Press <Return> to open the Option Window and cursor to your selection, and press <Return> again to accept the entry and close the window. Expert users may wish to cursor to the Attr field and press the hot keys 1 through 3 to select the attributes.

### **Template Label**

This field accepts up to 16 characters. The template itself will limit the number of characters you can use depending on whether you use a normal or double-wide template, and whether you use normal, quad or double-high characters. Be sure to view the template on the editor's screen to assure the correct appearance.

### **Conditional Expression**

The conditional expression placed in this field must be a single word or bit reference which evaluates to true or false. When a word reference is evaluated, if the result is even (least significant bit = 0), the value is false; and if the result is odd (least significant bit = 1), the value is true. When in the Run Mode, if a reference evaluates to true, the template characteristics defined for the line that is true will be used to display the template on the page. If more than one expression is true at the same time, the line with the highest priority will be displayed, with line 1 having the highest priority and line 5 having the lowest priority.

When an expression results in an invalid equation, no value will be displayed on the screen. If an expression previously resulted in a valid display, but in a later scan resulted in an invalid equation, the previous display will be erased. Also, when an input value expression results in an invalid equation, an error message will be displayed on the screen and no value will be sent to the PLC.

This field accepts up to 18 characters. For information regarding the format for PLC word references, consult the appropriate PLC chapter for your specific PLC brand.

The following conditional expression example is shown using a generic format. Refer to the appropriate PLC chapter for more specific addressing formats.

[204 06]

The conditional expression could be as simple as a single bit reference. This would resolve to true if the bit is on.

Note that the indicator template is configured with a single bit reference for each of the five display states. If control logic is required, then the PLC program must generate a specific bit to trigger a display state. The tilde (~) can be used to negate a value (e.g., ~[204 06]).

### **Aim (Alarm)**

The selections available are Y (yes) or N (no).

This field allows you to designate any line of the template definition as an alarm state. A Y in this field means that, if the reference in this line solves to true, an alarm message will be placed in the alarm list.

A Y also designates that this condition will be monitored at all times, regardless of the page that is in view. Therefore, judicious use of this alarm state is recommended to maximize the response time of the system.

### **Ack (Acknowledge Required)**

The selections available are Y (yes) or N (no). If Y is entered, the corresponding alarm message must be acknowledged by the online operator before it is removed. If the alarm does not merit acknowledgment by the operator, then N may be entered into the field, and the alarm message will automatically be removed from the list when the alarm condition clears.

## **Control Button Definition Table**

---

This Control Button Definition Table is used to define the control buttons on the right side of your unit. Line 1 of the table corresponds to the top control button; line 2 corresponds to the control button that is second from the top, etc. It is not necessary to use all control buttons. Simply leave a line blank if you do not want a control button at that location.

If a control button is defined, a small arrow will be displayed in the lower left corner of the template to indicate to the operator that a control function is available.

When the control button is pressed, the PanelMate unit sends a command to the PLC to set the referenced bit (e.g., [120 00]) to a 1. When the button is released, a separate command is sent to set the bit to a 0, thus providing a momentary input to the PLC. If a maintained input is desired, the bit may be latched in PLC logic.

### **Attr (Character Attributes)**

This field allows you to select the display attributes of the control button. The selections available are NORM (normal, black letters on white background), REVR (reverse, white letters on black background), and BLINK (blink, alternating between normal and reverse). Press <Return> to open the Option Window and cursor to your selection, and press <Return> again to accept the entry and close the window. Expert users may wish to cursor to the Attr field and press the hot keys 1 through 3 to select the attributes.

### **Control Label**

This field accepts two lines of 8 normal-size alphanumeric characters. The characters will automatically wrap to the next line so you can eliminate a carriage return in some instances. If you wish to center your label, insert spaces or a carriage return (<Ctrl> <m>) to move the text to the desired location.

### **PLC Bit Reference**

This field accepts 18 alphanumeric characters. This field defines which PLC bit will be turned on when an operator presses the corresponding control button. It is not possible to use any expression or conditional logic in this field (including a logical NOT).

## **Editing Existing Templates**

---

To edit an existing template, use the cursor arrow keys in the Page Editor to select the template to be edited and press <F1>. The Indicator Template Editor will immediately appear on the screen with the fields filled-in as you last saved them for the selected template.

## **Exit the Indicator Template Editor**

---

To exit the Indicator Template Editor and return to the Page Editor - Template Mode, press <F10>.

## **Gathering Information for Configuration**

---

Before beginning configuration, it will probably be useful to gather all the information you will need. The form provided on the following page may be reproduced and used to organize your data prior to entry into the PanelMate unit. When a form is completed, you will have gathered all the information you will need for this particular template.

## INDICATOR TEMPLATE EDITOR

Template Size: NORMAL or DOUBLE-WIDE

Character Size: NORMAL or QUAD or DOUBLE-HIGH

Device Name (16 char): \_\_\_\_\_

Priority	Attr	Template Label (16 char)	PLC Bit Reference (70 char)	Alm	Ack
1					
2					
3					
4					
5					

Button	Attr	Control Label (16 char)	PLC Bit Reference (18 char)
1			
2			
3			
4			

**Note** Use <Ctrl> <m> to insert a carriage return in text fields.



# Chapter 16

## Readout Template Editor

---

In this chapter, you will learn:

- How Readout Templates can be used
- How to define a Readout Template
- How to edit existing Readout Templates
- How to return to the Page Editor

# Functions of Readout Templates

Readout Templates are designed to be used as numerical readout devices on a control panel and are used to display a digital value. The PanelMate unit also provides two ways for the operator to change a value.

This single editor is used to define all the characteristics of a Readout Template including the values it displays, its high and low alarm limits, and all control functions. (Note that all the field visual attributes are fixed for Readout Templates.) The following section describes how each field in this editor relates to the template, and what the appropriate field entries might be. Refer to the figure below as needed.

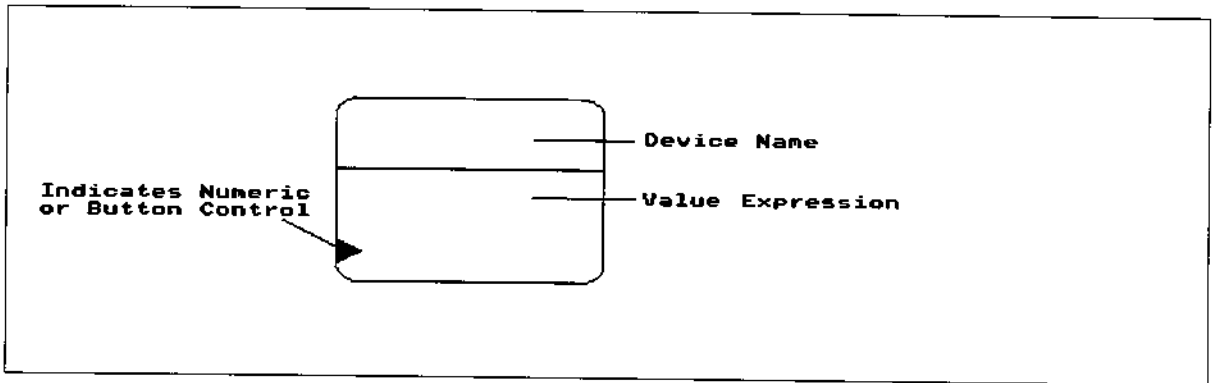


Figure 16-1 Readout Template

The following figure shows a representation of the Readout Template Editor. Each of the fields which compose the spreadsheet is reviewed in the following sections.

**READOUT TEMPLATE EDITOR**

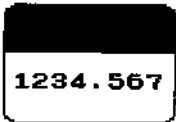
	Template Size/Character Size <input type="text"/>	Decimal Places <input type="text"/>
	Device Name <input type="text"/>	
Value Expression	<input type="text"/>	
High Alarm Expression	<input type="text"/>	
Low Alarm Expression	<input type="text"/>	
Deadband Range	<input type="text"/> % of (High Alarm - Low Alarm)	
Alarm Acknowledgement	<input type="checkbox"/>	
Control Type	<input type="text" value="NONE"/>	

Figure 16-2 Readout Template Editor

To edit a text field, cursor to the field and press <Return> to open the field. Type the text. Press <Return> to close the field or <Esc> to revert to the old value.

Other fields have Option Windows which pop-up on the screen. To edit this type of field cursor to the field and press <Return>. Use the cursor keys to scroll through and highlight your selection. Press <Return> to accept the change or <Esc> to revert to the previous value.

Option Windows display all possible choices and will cursor over selections which are not permissible choices based upon your current configuration.

To exit the Readout Template Editor, press <F10>.

---

## Template Size/Character Size

The selections available are NORMAL/NORMAL, NORMAL/QUAD, NORMAL/DOUBLE-HIGH, or DOUBLE-WIDE/QUAD. The maximum number of digits that can be displayed in each combination of template/character size is: normal/normal, 8 digits; normal/quad, 4 digits; normal/double-high, 8 digits; double-wide/quad, 9 digits.

---

## Decimal Places

This field accepts the numbers 0 through 8. This field defines how the number will be formatted on the template.

---

## Device Name

This field accepts 16 normal-size characters in 2 lines. Only normal-size characters are used in this field. Use <Ctrl> <m> to insert a carriage return, and the space bar to add spaces if you wish to center the device name.

---

## Value Expression

Value is the value that will be displayed in the center of the template. This field accepts up to 70 characters.

The expression entered here may include a single PLC word or bit reference and a single factor of 10 scaling expression.

Note that if a value is too large to display in the template, the most significant digits will be displayed and the least significant digits will be truncated.

The following examples of expressions are shown using a generic format. Refer to the appropriate PLC chapter for more specific addressing formats.

[123]

The expression could be as simple a single word reference. This example references word 123.

[123]\*1000, [123]\*100, [123]\*10, [123]\*1, [123]\*.1, [123]\*.01, [123]\*.001

This is a mathematical expression that includes PLC references and a factor of 10 that will solve to a value.

## High Alarm Expression

---

The results of the High Alarm Expression are compared to the results of the Value Expression. If Value exceeds the high alarm, an alarm message will be placed in the alarm list and the numeric display of the Value will blink.

This is an optional entry. If no alarm is desired for this device, leave this field blank.

The expression entered here may include a single PLC word and bit reference and a single factor of 10 scaling expression. You may also enter a single constant value (e.g., 900) as an expression.

This field accepts up to 70 characters.

## Low Alarm Expression

---

The results of the Low Alarm Expression are compared to the results of the Value Expression. If Value exceeds the low alarm, an alarm message will be placed in the alarm list and the numeric display of the Value will blink.

This is an optional entry. If no alarm is desired for this device, leave this field blank.

The expression entered here may include a single PLC word and bit reference and a single factor of 10 scaling expression. You may also enter a single constant value (e.g., 900) as an expression.

This field accepts up to 70 characters.

## Deadband Range

---

The deadband range is an area below the high alarm value and above the low alarm value that must be crossed before Value is considered to have returned to normal status (go out of alarm). The deadband range prevents multiple alarm messages being generated when Value is hovering around an alarm threshold.

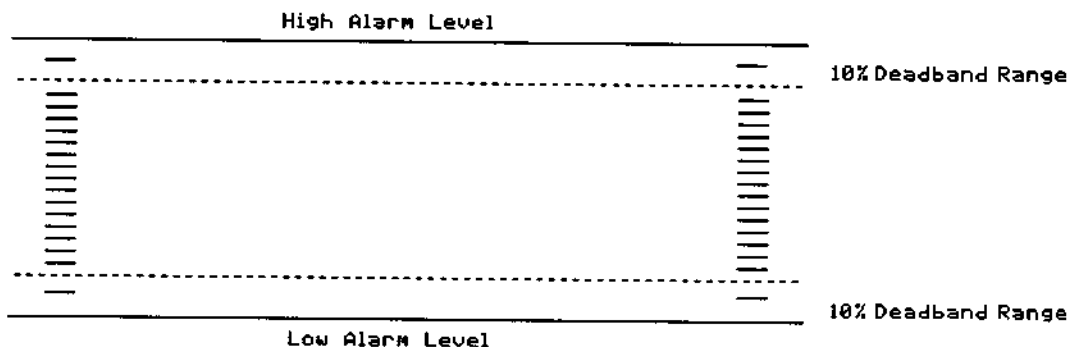


Figure 16-3 Deadband

This field accepts the numbers 0 through 99. These numbers represent the percentage of the high alarm value minus the low alarm value that defines the width of the deadband.

## Alarm Acknowledgment

The selections available are Y (Yes) or N (No). If Y is entered, the corresponding alarm message must be acknowledged by the online operator before it is removed. If the alarm does not merit acknowledgment by the operator, then N may be entered into the field, and the alarm message will automatically be removed.

## Control Type

The selections available are NONE, NUMERIC or BUTTONS.

A Readout Template may be defined to show a value without the operator being able to control it. For this type of template, select NONE.

Select NUMERIC if the operator will be directed to use the numeric keypad to enter a (setpoint) value. When this selection is made, two new fields will appear on the screen. These fields, Target Word Address and Password Protection, are described in the next section.

Select BUTTONS if the operator will be directed to use the control buttons to change a (setpoint) value. It is likely that you will use buttons labeled "increase" and "decrease", or a similar system, to change this value. When this selection is made, a Control Button Definition Table will appear on the screen. This table is described in the next section.

If either numeric or button control is defined, a small arrow will be displayed in the lower left corner of the template to indicate to the operator that a control function is available.

## Numeric Control Definition

The numeric control definition consists of two entries: Target Word Address and Password Protection. The Target Word Address is the PLC word reference that will store the result of the operator input. Password Protection will permit the selection of a layer of security for numeric entry if desired.

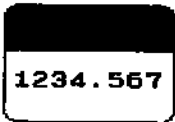
READOUT TEMPLATE EDITOR	
	Template Size/Character Size <input type="text"/> Decimal Places <input type="text"/>
	Device Name <input type="text"/>
Value Expression	<input type="text"/>
High Alarm Expression	<input type="text"/>
Low Alarm Expression	<input type="text"/>
Deadband Range	<input type="text"/> % of (High Alarm - Low Alarm)
Alarm Acknowledgement	<input type="checkbox"/>
Control Type	<input type="text" value="NUMERIC"/>
Target Word Address	<input type="text"/>
Password Protection	<input type="text"/>

Figure 16-4 Numeric Control Definition

## Target Word Address

This field defines the location of the operator's input in the PLC. This field accepts up to 23 characters.

The target word address entered here may include a single PLC word or bit reference and a single factor of 10 scaling expression.

The following examples of expressions are shown using a generic format. Refer to the appropriate PLC chapter for more specific addressing formats.

[123]

The expression could be as simple a single word reference. This example references word 123.

[123]\*1000, [123]\*100, [123]\*10, [123]\*1, [123]\*.1, [123]\*.01, [123]\*.001

These are mathematical expressions that include a PLC reference and a factor of 10 that will solve to a value.

## Password Protection

It is possible to lockout access to numeric entry unless the operator provides the correct password to the PanelMate unit. The selections available are None, A Only, B Only, or A or B. Password protection must be validated each time a template is selected for numeric entry. See Chapter 22, Defining System Parameters, for more information.

## Control Button Definition Table

The Control Button Definition Table is used to define the control buttons on the right side of your unit. Line 1 of the table corresponds to the top control button, line 2 corresponds to the control button that is second from the top, etc. It is not necessary to use all control buttons. Simply leave a line blank if you do not want a control button at that location.

When the control button is pressed, the PanelMate unit sends a command to the PLC to set the referenced bit (e.g., [120 00]) to a 1. When the button is released, a separate command is sent to set the bit to a 0, thus providing a momentary input to the PLC. If a maintained input is desired, the bit may be latched in PLC logic.

The screenshot shows the 'READOUT TEMPLATE EDITOR' interface. On the left, a readout display shows the value '1234.567'. To the right, there are several configuration fields: 'Template Size/Character Size' and 'Decimal Places' (both empty), 'Device Name' (empty), 'Value Expression' (empty), 'High Alarm Expression' (empty), 'Low Alarm Expression' (empty), 'Deadband Range' (empty), and 'Alarm Acknowledgement' (checkbox). Below these is a 'Control Type' dropdown menu set to 'BUTTONS'. At the bottom, the 'CONTROL BUTTON DEFINITION TABLE' is shown with columns for 'Attr', 'Control Label', and 'PLC Bit Reference'. The table has four rows, with the first row containing a box for 'Attr', a box for 'Control Label', a box for 'PLC Bit Reference', and a right-pointing arrow.

Figure 16-5 Control Button Definition Table

### **Attr (Character Attributes)**

This field allows you to select the display attributes of the control button. The selections available are NORM (normal, black letters on white background), REVR (reverse, white letters on black background), and BLINK (blink, alternating between normal and reverse). Press <Return> to open the Option Window and cursor to your selection, and press <Return> again to accept the entry and close the window. Expert users may wish to cursor to the Attr field and press the hot keys 1 through 3 to select the attributes.

### **Control Label**

This field accepts two lines of 8 normal-size alphanumeric characters. The characters will automatically wrap to the next line so you can eliminate a carriage return in some instances. If you wish to center your label, insert spaces and/or a carriage return (<Ctrl> <m>) to move the text to the desired location.

### **PLC Bit Reference**

This field accepts 18 alphanumeric characters. This field defines which PLC bit will be turned on when an operator presses the corresponding control button. It is not possible to use any expression or conditional logic in this field (including a logical NOT).

## **Editing Existing Templates**

To edit an existing template, use the cursor arrow keys in the Page Editor - Template Mode to select the template to be edited and press <F1>. The Readout Editor will immediately appear on the screen with the fields filled in as you last saved them for the selected template.

## **Exit the Readout Template Editor**

To exit the Readout Template Editor and return to the Page Editor - Template Mode, press <F10>.

## **Gathering Information for Configuration**

Before beginning configuration, it will probably be useful to gather all the information you will need. The form provided on the following page may be reproduced and used to organize your data prior to entry into the PanelMate unit. When the form is completed, you will have gathered all the information you will need for this template.

## READOUT TEMPLATE EDITOR

Template Size/Character Size: NORMAL/NORMAL, NORMAL/QUAD,  
NORMAL/DOUBLE-HIGH, or DOUBLE-WIDE/QUAD

Decimal Places (0-8): \_\_\_\_\_

Decimal Name (16 char): \_\_\_\_\_

Value Expression (70 char): \_\_\_\_\_

High Alarm Expression (70 char): \_\_\_\_\_

Low Alarm Expression (70 char): \_\_\_\_\_

Deadband Range (0-99%): \_\_\_\_\_

Alarm Acknowledgement: \_\_\_\_\_

Control Type: NONE or NUMERIC or BUTTONS

If NUMERIC,

Target Word Address: \_\_\_\_\_

Password Protection    \_\_\_NONE    \_\_\_A    \_\_\_B    \_\_\_A or B

If BUTTONS,

Button	Attr	Control Label (36 char)	PLC Bit Reference (18 char)
1			
2			
3			
4			

**Note**    Use <Ctrl> <m> to insert a carriage return in text fields.

# Chapter 17

## Bar Template Editor

---

In this chapter, you will learn:

- How Bar Templates can be used
- How to define a Bar Template
- How to edit existing Bar Templates
- How to return to the Page Editor

## Functions of Bar Templates

Bar Templates are designed to be used as the analog meters and faceplates on a control panel and are used to indicate a value in analog fashion, with a bar graph. This bar graph can show actual value, setpoint, and high and low alarm levels. The actual value and setpoint are also displayed digitally. The PanelMate unit also provides two ways for the operator to change the setpoint value.

This single editor is used to define all the characteristics of a Bar Template including the bar's upper and lower limits, a setpoint position, high and low alarm limits, and all control functions. (Note that all the field attributes are fixed for Bar Templates.) The following section describes how each field in this editor relates to the template, and what the appropriate field entries might be. Refer to the figure on the next page as needed.

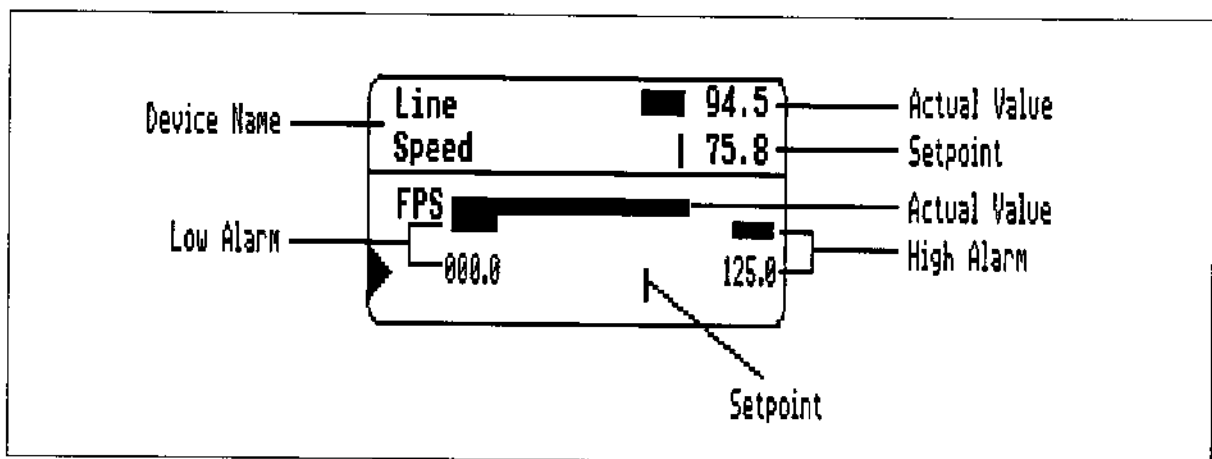


Figure 17-1 Bar Template

The following figure shows a representation of the Bar Template Editor. Each of the fields which compose the spreadsheet is reviewed in the following sections.

**BAR TEMPLATE EDITOR**

Template Size   
 Device Name   
 Units

Maximum Calibration   
 Minimum Calibration   
 Actual Value Expression   
 Setpoint Value Expression   
 High Alarm Expression   
 Low Alarm Expression   
 Deadband Range  % of (High Alarm - Low Alarm)  
 Alarm Acknowledgement   
 Control Type

**Figure 17-2 Bar Template Editor**

To edit a text field, cursor to the field and press <Return> to open the field. Type the text. Press <Return> to close the field or <Esc> to revert to the old value.

Other fields have Option Windows which pop-up on the screen. To edit this type of field, cursor to the field and press <Return>. Use the cursor keys to scroll through and highlight your selection. Press <Return> to accept the change or <Esc> to revert to the previous value.

Option Windows display all possible choices and will cursor over selections which are not permissible choices based upon your current configuration.

To exit the Bar Template Editor page, press <F10>.

## **Template Size**

---

The selections available are 2WIDE or 3WIDE. Remember that for placing the template on the page, the cell cursor is always the left cell of the template.

## **Device Name**

---

This field accepts 16 normal-size characters in 2 lines. Only normal-size characters are used in this field. Use <Ctrl> <m> to insert a carriage return and the space bar to add spaces if you wish to center the device name.

## Units

---

This field accepts 3 alphanumeric characters. It defines the type of units that are being displayed to the operator, such as "Deg" or "gal".

## Maximum Calibration

---

This is a 5-character field that accepts 5 digits, or 4 digits with a decimal point placed anywhere in the field.

The Maximum Calibration is the value that defines the highest point of the Actual Value bar. This value will appear on the template.

## Minimum Calibration

---

This is a 5-character field that accepts 5 digits, or 4 digits with a decimal point placed anywhere in the field.

The Minimum Calibration is the value that defines the lowest point of the Actual Value bar. This value will appear on the template.

Note that the PanelMate unit will use the Maximum and Minimum Calibrations to calculate the bar's midpoint and place that value on the template too.

## Actual Value Expression

---

Actual Value is the value that will be displayed as a full dark bar on the template. This field accepts up to 70 characters.

The expression entered here may include a single PLC word or bit reference and a single factor of 10 scaling expression.

Note that if a value is too large to display in the template, the most significant digits will be displayed and the least significant digits will be truncated.

The following examples of expressions are shown using a generic format. Refer to the appropriate PLC chapter for more specific addressing formats.

[123]

The expression could be as simple as a single word reference. This example references word 123.

[123]\*1000, [123]\*100, [123]\*10, [123]\*1, [123]\*.1, [123]\*.01, [123]\*.001

This is a mathematical expression that includes PLC references and constants that will solve to a value.

## **Setpoint Value Expression**

---

Setpoint Value is the value that will be displayed as a dark vertical line below the of the Actual Value bar.

The expression entered here may include a single PLC word or bit reference and a single factor of 10 scaling expression.

Note that if a value is too large to display in the template, the most significant digits will be displayed and the least significant digits will be truncated.

This optional field accepts up to 70 characters.

## **High Alarm Expression**

---

The results of the High Alarm Expression are compared to the results of the Actual Value Expression. If the Actual Value exceeds the high alarm, an alarm message will be placed in the alarm list and the numeric display of the Actual Value will blink. A High Alarm bar is shown below the Actual Value Expression.

This is an optional entry. If no alarm is desired for this device, leave this field blank.

The expression entered here may include a single PLC word or bit reference and a single factor of 10 scaling expression. You may also enter a single constant value (e.g., 900) as an expression.

This field accepts up to 70 characters.

## **Low Alarm Expression**

---

The results of the Low Alarm Expression are compared to the results of the Actual Value Expression. If the Actual Value exceeds the low alarm, an alarm message will be placed in the alarm list and the numeric display of the Actual Value will blink. A Low Alarm bar is shown below the Actual Value Expression.

This is an optional entry. If no alarm is desired for this device, leave this field blank.

The expression entered here may include a single PLC word or bit reference and a single factor of 10 scaling expression. You may also enter a single constant value (e.g., 900) as an expression.

This field accepts up to 70 characters.

## Deadband Range

---

The deadband range is an area below the high alarm value and above the low alarm value, that must be crossed before Value is considered to have returned to normal status (go out of alarm). The deadband range prevents multiple alarm messages from being generated when Actual Value is hovering around an alarm threshold.

This field accepts the numbers 0 through 99. These numbers represent the percentage of the high alarm value minus the low alarm value that defines the width of the deadband.

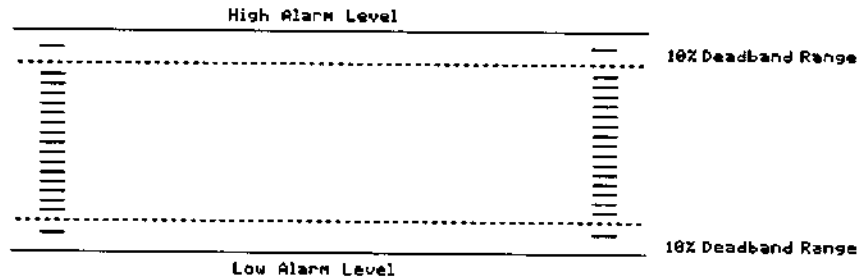


Figure 17-3 Deadband

## Alarm Acknowledgment

---

The selections available are Y (Yes) or N (No). This field will accept a Y or N. If Y is entered, the corresponding alarm message must be acknowledged by the online operator before it is removed. If the alarm does not merit acknowledgment by the operator, then N may be entered into the field, and the alarm message will automatically be removed.

## Control Type

---

The selections available are NONE, NUMERIC, or BUTTONS.

A Bar Template may be defined to show an analog graph without the operator being able to control it. For this type of template, select NONE.

Select NUMERIC if the operator will be directed to use the numeric keypad to enter a (setpoint) value. When this selection is made, two new fields will appear on the screen. These fields, Target Word Address and Password Protection, are described in the next section.

Select BUTTONS if the operator will be directed to use the control buttons to change a (setpoint) value. It is likely that you will use buttons labeled "increase" and "decrease", or a similar system, to change this value. When this selection is made, a Control Button Definition Table will appear on the screen. This table is described in the following section.

If either numeric or button control is defined, a small arrow will be displayed in the lower left corner of the template to indicate to the operator that a control function is available.

## Numeric Control Definition

The numeric control definition consists of two entries, the Target Word Address and Password Protection. The Target Word Address is the PLC word reference that will store the result of the Input Value Expression. Password Protection will permit the selection of a layer of security for numeric entry if desired.

**BAR TEMPLATE EDITOR**

Template Size   
Device Name   
Units

Maximum Calibration   
Minimum Calibration   
Actual Value Expression   
Setpoint Value Expression   
High Alarm Expression   
Low Alarm Expression   
Deadband Range  % of (High Alarm - Low Alarm)  
Alarm Acknowledgement

Control Type

Target Word Address   
Password Protection

Figure 17-4 Numeric Control Definition

### Target Word Address

This field defines the location of the operator's input in the PLC. This field accepts up to 23 characters.

The target word address entered here may include a single PLC word or bit reference and a single factor of 10 scaling expression.

The following examples of expressions are shown using a generic format. Refer to the appropriate PLC chapter for more specific addressing formats.

[123]

The expression could be as simple a single word reference. This example references word 123.

[123]\*1000, [123]\*100, [123]\*10, [123]\*1, [123]\*.1, [123]\*.01, [123]\*.001

These are mathematical expressions that include a PLC reference and a factor of 10 that will solve to a value.

### Password Protection

It is possible to lockout access to numeric entry unless the operator provides the correct password to the PanelMate unit. The selections available are None, A Only, B Only, or A or B. Password protection must be validated each time the template is selected for numeric entry. See Chapter 22, Defining System Parameters, for more information.

## Control Button Definition Table

This Control Button Definition Table is used to define the four control buttons on the right side of your unit. Line 1 of the table corresponds to the top control button, line 2 corresponds to the control button that is second from the top, etc. It is not necessary to use all control buttons. Simply leave a line blank if you do not want a control button at that location.

When the control button is pressed, the PanelMate unit sends a command to the PLC to set the referenced bit (e.g., [120 00]) to a 1. When the button is released, a separate command is sent to set the bit to a 0, thus providing a momentary input to the PLC. If a maintained input is desired, the bit may be latched in PLC logic.

**BAR TEMPLATE EDITOR**

58.00  
148.00

0.000      100.0

Template Size

Device Name

Units

Maximum Calibration

Minimum Calibration

Actual Value Expression

Setpoint Value Expression

High Alarm Expression

Low Alarm Expression

Deadband Range  % of (High Alarm - Low Alarm)

Alarm Acknowledgement

Control Type

**CONTROL BUTTON DEFINITION TABLE**

	Attr	Control Label	PLC Bit Reference	
1				➔
2				
3				
4				

Figure 17-5 Control Button Definition Table

### Attr (Character Attributes)

This field allows you to select the display attributes of the control button. The selections available are NORM (normal, black letters on white background), REVR (reverse, white letters on black background), and BLINK (blink, alternating between normal and reverse). Press <Return> to open the Option Window and cursor to your selection, and press <Return> again to accept the entry and close the window. Expert users may wish to cursor to the Attr field and press the hot keys 1 through 3 to select the attributes.

### Control Label

This field accepts two lines of 8 normal-size alphanumeric characters. The characters will automatically wrap to the next line so you can eliminate a carriage return in some instances. If you wish to center your label, insert spaces or a carriage return (<Ctrl> <m>) to move the text to the desired location.

### **PLC Bit Reference**

This field accepts 18 alphanumeric characters. This field defines which PLC bit will be turned on when an operator presses the corresponding control button. It is not possible to use any expression or conditional logic in this field (including a logical NOT).

### **Editing Existing Templates**

---

To edit an existing template, use the cursor arrow keys in the Page Editor - Template Mode to select the template to be edited and press <F1>. The Bar Template Editor will immediately appear on the screen with the fields filled in as you last saved them for the selected templates.

### **Exit the Bar Template Editor**

---

To exit the Bar Template Editor and return to the Page Editor - Template Mode, press <F10>.

## **Gathering Information for Configuration**

---

Before beginning configuration, it will probably be useful to gather all the information you will need. The form provided on the following page may be reproduced and used to organize your data prior to entry into the PanelMate unit. When a form is completed, you will have gathered all the information you will need for this particular template.

## BAR TEMPLATE EDITOR

Template Size: 2WIDE or 3WIDE

Device Name (16 char): \_\_\_\_\_

Units (3 char): \_\_\_\_\_

Maximum Calibration (6 char): \_\_\_\_\_

Minimum Calibration (6 char): \_\_\_\_\_

Actual Value Expression (70 char): \_\_\_\_\_

Setpoint Value Expression (70 char): \_\_\_\_\_

High Alarm Expression (70 char): \_\_\_\_\_

Low Alarm Expression (70 char): \_\_\_\_\_

Deadband Range (0-99%): \_\_\_\_\_

Alarm Acknowledgement: \_\_\_\_\_

Control Type: NONE or NUMERIC or BUTTONS

If NUMERIC,

Target Word Address (18 char): \_\_\_\_\_

Password Protection    \_\_\_NONE    \_\_\_A    \_\_\_B    \_\_\_A or B

If BUTTONS,

Button	Attr	Control Label (16 char)	PLC Bit Reference (18 char)
1			
2			
3			
4			

**Note**    Use <Ctrl> <m> to insert a carriage return in text fields.

# Chapter 18

## Display Template Editor

---

In this chapter, you will learn:

- How Display Templates can be used
- How to define a Display Template
- How to edit existing Display Templates
- How to return to the Page Editor

# Functions of Display Templates

Display Templates are designed to be used like LED or LCD message units or displays. They are most effective when used for informational messages and not as alarm messages. Three independent lines of text can be written in a Display Template, with each line consisting of up to 28 characters. (Note that it is possible for quad or double-high character lines to interfere with each other. Therefore, be sure to test all message combinations that you expect to use before going online.) The Message Library will hold up to 100 lines for the PanelMate Series 1000.

This single editor is used to define all the characteristics of a Display Template including its location, size and all control functions. The following section describes how each field in this editor relates to the template, and what the appropriate field entries might be. Refer to the following figure as needed.

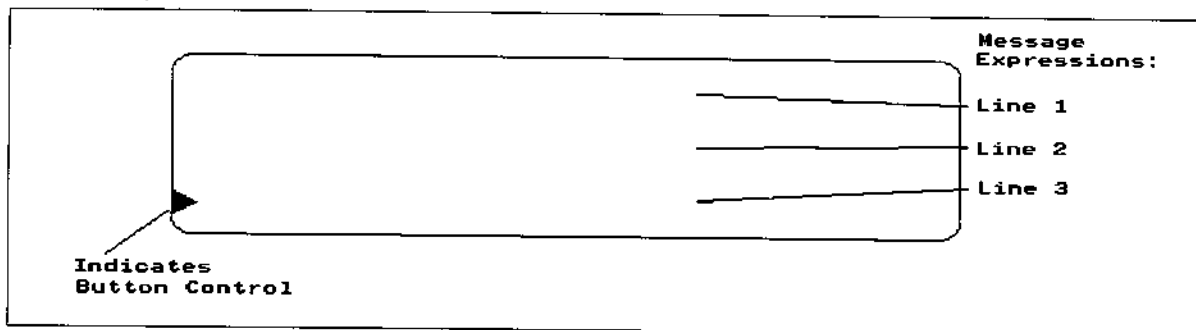


Figure 18-1 Display Template

The actual creation of the message is performed in the Message Library Editor. To access the Message Library Editor, you must exit the Display Template Editor and the Page Editor - Template Mode, then press <F3> to enter the Message Library Editor. The Message Library Editor is discussed further in chapter 21.

The following figure shows a representation of the Display Template Editor. Each of the fields which compose the spreadsheet is reviewed in the following sections.

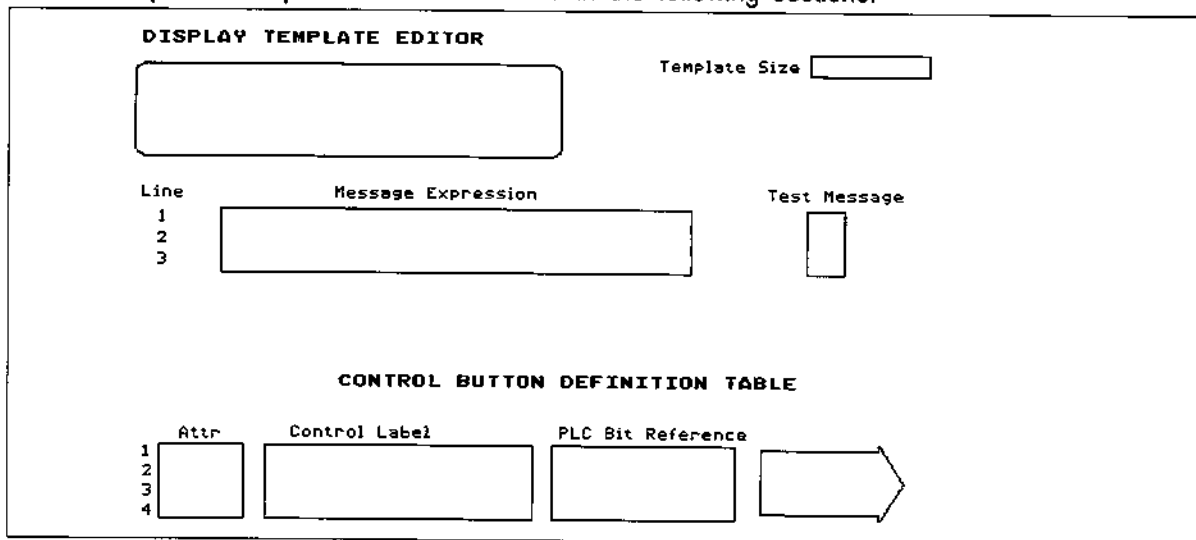


Figure 18-2 Display Template Editor

To edit a text field, cursor to the field and press <Return> to open the field. Type the text. Press <Return> to close the field or <Esc> to revert to the old value.

Other fields have Option Windows which pop-up on the screen. To edit this type of field, cursor to the field and press <Return>. Use the cursor keys to scroll through and highlight your selection. Press <Return> to accept the change or <Esc> to revert to the previous value.

Option Windows display all possible choices and will cursor over selections which are not permissible choices based upon your current configuration.

To exit the Display Template Editor page, press <F10>.

## **Template Type**

---

The selections available are 2WIDE or 3WIDE. When placing the template on the page, the cell cursor is always the leftmost cell of the template. A 2WIDE template will display a message length of up to 18 normal font characters. A 3WIDE template message length will display up to 28 characters.

## **Message Expression**

---

This field accepts up to 70 characters. The PLC reference must contain a value from 1 to 100. If the Message Expression results in a number greater than permitted or less than 0 when running online, the previously displayed message will be erased.

When a PLC reference expression results in an invalid value (i.e., negative value), no message will be displayed on the screen. If a message expression previously resulted in a valid value, but in a later scan resulted in an invalid equation, the previously displayed message will be erased.

The value of this expression selects which message will be displayed. Note that the lines are numbered 1, 2, and 3 to the left of the Message Expression field. There is one message expression for each line.

When running online, if the message expression results in a value less than 0 or greater than permitted, then the previously displayed message will be erased.

## **Test Display**

---

To see something in the Display Template during configuration, you may insert a message number in the test message field. The message corresponding to that number will be displayed on the template line you designated. If there is no message defined for that number, nothing will appear.

Note that when you return to the Page Editor, only Message 1 will be displayed, regardless of the message numbers listed in the Test Display fields. To fully test a Display Template, you must test in Run Mode.

The Message Library, described in Chapter 19, is used to define messages.

## **Control Button Definition Table**

---

The Control Button Definition Table is used to define the control buttons on the right side of your unit. Line 1 of the table corresponds to the top control button, line 2 corresponds to the control button that is second from the top, etc. It is not necessary to use all control buttons. Simply leave a line blank if you do not want a control button at that location.

If a control button is defined, a small arrow will be displayed in the lower left corner of the template to indicate to the operator that a control function is available.

When the control button is pressed, the PanelMate unit sends a command to the PLC to set the referenced bit (e.g., [120 00]) to a 1. When the button is released, a separate command is sent to set the bit to a 0, thus providing a momentary input to the PLC. If a maintained input is desired, the bit may be latched in PLC logic.

### **Attr (Character Attributes)**

This field allows you to select the display attributes of the control button. The selections available are NORM (normal, black letters on white background), REVR (reverse, white letters on black background), and BLINK (blink, alternating between normal and reverse). Press <Return> to open the Option Window and cursor to your selection, and press <Return> again to accept the entry and close the window. Expert users may wish to cursor to the Attr field and press the hot keys 1 through 3 to select the attributes.

### **Control Label**

This field accepts two lines of 8 normal-size alphanumeric characters. The characters will automatically wrap to the next line so you can eliminate a carriage return in some instances. If you wish to center your label, insert spaces or a carriage return (<Ctrl> <m>) to move the text to the desired location.

### **PLC Bit Reference**

This field accepts 18 alphanumeric characters. This field defines which PLC bit will be turned on when an operator presses the corresponding control button. It is not possible to use any expression or conditional logic in the field (including a logical NOT).

## **Editing Existing Templates**

---

To edit an existing template, use the cursor arrow keys in the Page Editor - Template Mode to select the template to be edited and press <F1>. The Display Template Editor will immediately appear on the screen with the fields filled in as you last saved them for the selected template.

## **Exit the Display Template Editor**

---

To exit the Display Template Editor and return to the Page Editor - Template Mode, press <F10>.

## **Gathering Information for Configuration**

---

Before beginning configuration, it will probably be useful to gather all the information you will need. The forms provided on the following pages may be reproduced and used to organize your data prior to entry into the PanelMate unit. When the forms are completed, you will have gathered all the information you will need for this particular template.

## DISPLAY TEMPLATE EDITOR

Template Size: 2WIDE or 3WIDE

Line	Display Expression (70 char)	Test Message
1		
2		
3		

Button	Attr	Control Label (16 char)	PLC Bit Reference (18 char)
1			
2			
3			
4			

**Note** Use <Ctrl> <m> to insert a carriage return in text fields.

# Chapter 19

## Message Library Editor

---

In this chapter, you will learn:

- How to add or edit text messages

# Message Library

---

The Message Library Editor is entered from the Page Editor Main Menu. The Message Library defines the contents, the visual attributes of the character, the character sizes, and the destination of one-line messages. The PanelMate Series 1000 will support a maximum of 100 messages. Note that each line of text is totally independent, so care must be taken when selecting character attributes and character size. It is possible for quad or double-high character lines to interfere with each other. Therefore, be sure to test all message combinations that you expect to use before going online.

F1=	F2=	F3=PREVIOUS	F4=NEXT	F5=
F6=MEM FREE	F7=	F8=	F9=SAVE	F10=EXIT

Figure 19-1 Message Library Editor Main Menu

<F3> = PREVIOUS allows you to scroll back to the previous 15 messages  
<F4> = NEXT allows you to scroll forward to the next 15 messages

Each of the fields which compose the Message Library are reviewed in the following sections.

## Msg# (Message Number)

All the messages are listed in numerical order. By pressing <Return>, you may enter the Message Number you wish to access in this field to scroll through the listing.

## Attr (Character Attributes)

This field allows you to select the display attributes of the control button. The selections available are NORM (normal, black letters on white background), REVR (reverse, white letters on black background), and BLINK (blink, alternating between normal and reverse). Press <Return> to open the Option Window and cursor to your selection, and press <Return> again to accept the entry and close the window. Expert users may wish to cursor to the Attr field and press the hot keys 1 through 3 to select the attributes.

## Message Text

Up to 28 characters can be displayed on a full screen width message. The message placement will determine the number of characters used.

## Char Size (Character Size)

This field selects the character font for the entire message. The selections available are NORM (normal), DHIGH (double-high), or QUAD.

### Note about the representation area

The currently selected message is displayed in the representation at the top of the page. This area also shows a line denoting the width of a 2WIDE and 3WIDE Display Template to assist in message alignment. A 2WIDE template will display a message length of up to 18 normal font characters. A 3WIDE template will display a message length of up to 28 normal font characters. The visual representation area shows where the right edge of the display template will display the last character.

## Register References Within Messages

---

Within the PanelMate unit, users may reference PLC register locations within a message in order to display the numeric register content within the message. Users may employ the following format expressions to display the contents of the registers. You may have up to five register references within a message.

Note that if a value is too large to display in the specified format width, a string of asterisks (\*\*\*\*\*) will be displayed for the value. For example, if a message was defined as three characters in length, but the value to be displayed was four characters, \*\*\* would be displayed for the value.

### General Format Expression

**Note** A message containing multiple PLC references will print to the screen multiple times -- once for each reference in the message.

\$tw.d(expression)

where--

\$ = format indicator

t = type of numeric display

I Integer display

D Floating decimal point real value display

H Hexadecimal display

O Octal display

B Binary display

F Fixed decimal point real value display

E Exponential display

A ASCII character display

w = total field width including decimal point, negative sign (-), and positive sign (+)

. = separator between width of format and the number of decimal places (used with F or E format)

d = number of decimal places (used with F or E format)

Format type D (floating decimal point) permits the decimal point to float in the display depending on the registers value. This contrasts with the format type F (fixed decimal point), which formats a value with a fixed decimal location. Format type F may be useful when creating a column of values.

**Note** Floating decimal point format type should not be confused with floating point mathematics or floating point data types which cannot be read or manipulated in the PanelMate unit.

Each format has a maximum number of digits it can display. A number cannot be completely displayed if the format description is too small. The following are the width limits for each format type.

I11	=	Largest Integer value width is 11
H8	=	Largest Hexadecimal value width is 8
O11	=	Largest Octal value width is 11
B32	=	Largest Binary value width is 32
D65	=	Largest Floating Decimal Point value width is 65
F65.d	=	Largest Fixed Decimal Point value width is 65
E65.d	=	Largest Exponential value width is 65
A	=	Largest ASCII character width is 2. (The least significant 16 bits are used in the following order: high byte, low byte). When using both characters, verify that the PanelMate unit's default format is capable of reading numbers which use the high byte. An alternate word reference format may be necessary, i.e., #U16.
d	=	decimal places

For example, if the message is:

"Current tank level is \$I3([123]) gallons.", and the value in register 123 is 567, then the appearance of the message on the screen would be:

"Current tank level is 567 gallons."

If the message is:

"Part name in line1 is \$A([200#U16]).", and the value in register 200 is 16693, the message will display the following:

"Part name in line1 is A5".

**Note** With the #U16 format, the PanelMate unit can read and display the ASCII equivalent of 16693.

### Decimal-Based Formats

The decimal-based format types are:

1. Integer
2. Floating decimal point real value
3. Fixed decimal point real value
4. Exponential

It should be noted that all the decimal-based numeric formats are right-justified and padded with leading blanks, if necessary. If a value for a decimal format has too many digits for the specified format size, then the presentation will have "\*" placed in it for the width of the format specified in the format code.

### Decimal Place Formats

For fixed decimal point format (F), the number for the total width of the formatted value (w) must be at least one greater than the number of decimal places (d). If negative values will be displayed, "w" must be at least two greater than "d".

For the exponential format (E), the total width of the formatted value (w) must be at least eight greater than the number of decimal places (d).

### Binary-Based Formats

The binary-based format types are:

1. Hexadecimal
2. Octal
3. Binary

For binary-based formats, digits will be inserted for the entire width of the format size; there is no blank padding. If a value for a binary format has too many digits for the specified format size, the most significant digits of the value will be truncated until the number will fit in the size specified.

Example:

value = 300	
Presentation with H4 format:	012C
Presentation with H2 format:	2C

The following table shows examples of the different formatting types. The data type, actual data, and visual appearance are shown. The heading on the column for visual appearance marks 13 column locations to help reference the placement of characters.

Type	Data	Columns													
		0	1	2	3	4	5	6	7	8	9	0	1	2	
I5	324												3	2	4
I4	521												5	2	1
I2	-8.73												-	9	
I3	7321												*	*	*
I4	824.67												8	2	5
D7	421.45												4	2	1 . 4 5 0
D4	23.45												2	3	. 5
H3	255												0	F	F
H5	-255												F	F	F 0 1
H2	300												2	C	
O4	54												0	0	6 6
O3	88.45												1	3	0
O1	21												5		
B9	100												0	0	1 1 0 0 1 0 0
B4	86												0	1	1 0
F5.1	523.46												5	2	3 . 5
F10.4	253.21													2	5 3 . 2 1 0 0
F5.2	326.23												*	*	* * *
F8.3	-43.888												-	4	3 . 8 8 8
F5.0	397.52													3	9 8
E12.3	-324.1												-	3	. 2 4 1 E + 0 2
E13.2	0.06734													6	. 7 3 E - 0 2
E9.0	156.2													2	E + 0 2
D4	999.89												1	0	0 0
D6	6245.21												6	2	4 5 . 2
D1	0.04												0		
D1	9.12												9		
D4	82345.2												*	*	* * *
D3	-1.444												-	1	
F7.3	619.52												6	1	9 . 5 2 0
F7.2	619.52													6	1 9 . 5 2
F6.2	619.52												6	1	9 . 5 2
F5.3	619.52												-	-	- - - -
F5.1	619.52												6	1	9 . 5
D7	619.52												6	1	9 . 5 2 0
D6	619.52												6	1	9 . 5 2
D5	619.52												6	1	9 . 5
D4	619.52													6	2 0
D3	619.52												6	2	0
E12.4	619.52													6	. 1 9 5 2 E + 0 2
E12.3	619.52													6	. 1 9 5 E + 0 2
A	16693												A	5	

Table 19-1 Formatting Types

## **Save <F9>**

---

Press <F9> to save the Message Library without exiting the editor.

## **Exit the Message Library Editor**

---

To exit the Message Library Editor and return to the Page Editor, press <F10>.

# **Gathering Information for Configuration**

---

Before beginning configuration, it will probably be useful to gather all the information you will need. The forms provided on the following pages may be reproduced and used to organize your data prior to entry into the PanelMate unit. When the forms are completed, you will have gathered all the information you will need for the message library.



# Chapter 20

## Table Template Editor

---

In this chapter, you will learn:

- How Table Templates can be used
- How to define a Table Template
- How to edit existing Table Templates
- How to return to the Page Editor

# Functions of Table Templates

Table Templates are designed to display a table of values and accept numeric entry for all of the items in the table. Table Templates may be used for machine setup or recipe entry or for any application requiring the high density display and entry of information. Refer to the figure below.

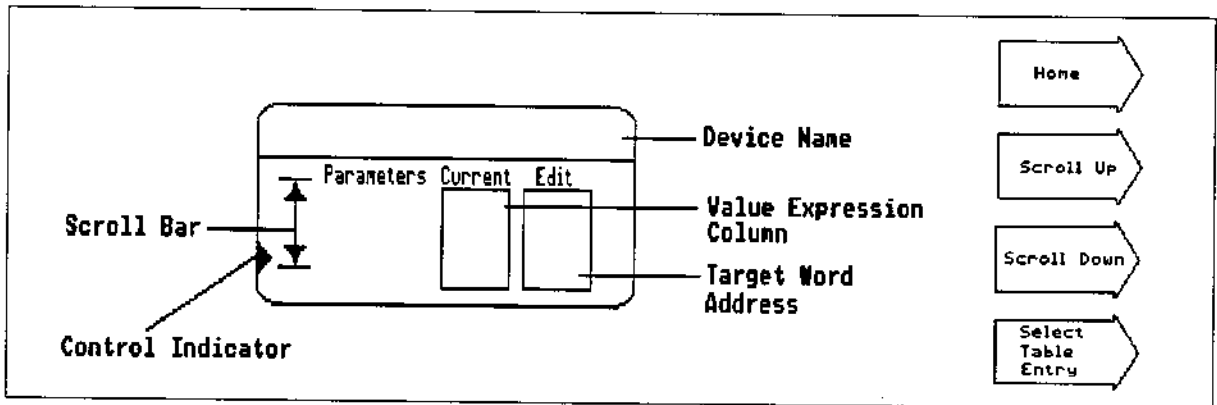


Figure 20-1 Table Template

A template may support up to 20 independent entries. Each entry has a tag name, current value, and edit value field. The template has built-in scroll capabilities to allow you to select the desired entry field. A scroll indicator is built into the left side of the template to indicate "top" and "bottom" which are signified by stop bars and "more" items which are identified by up or down arrows. The control buttons on the right of the screen permit up/down scrolling, return to home or open a selected field for numeric entry. Each of the fields which compose the spreadsheet is reviewed in the following sections. The control indicator at the bottom left of the template indicates control is available for a particular entry. You can configure each entry for numeric entry or just for display.

The following figure shows a representation of the Table Template Editor.

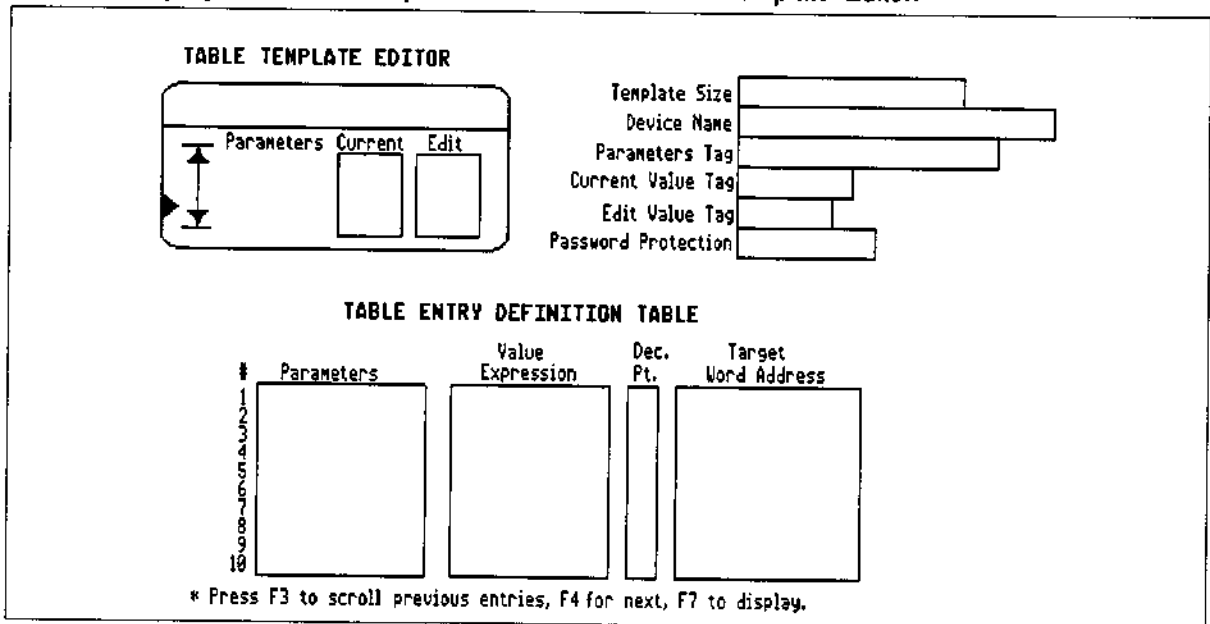


Figure 20-2 Table Template Editor

## **Template Size**

---

The selections available are 1HIGH or 2HIGH and 2WIDE or 3WIDE.

**Note** The height of the table template determines the number of table entries that may be displayed at one time. One table entry is comprised of one line below the column title line. For a single-high template, two entries may be displayed, for a double-high template, ten entries.

## **Device Name**

---

The field accepts up to 28 normal-size characters in a 3WIDE template. Only normal-size characters are used in this field. Add spaces if you wish to center the device name. Note that a 2WIDE template will only display up to 18 characters.

## **Parameter Tag**

---

This field accepts up to 16 normal-sized characters which will display as the title for the Parameter column. Note that a 2WIDE template will only display 12 characters. Use this field for tagname and units definition.

## **Current Value Tag**

---

This field accepts up to five normal-size characters which will display as the title for the Current Values column. These are the values which are read from the PLC. See the Value Expression section for more information.

## **Edit Value Tag**

---

This field is only displayed in a 3WIDE template. Up to five normal-size characters will display as the title for the Edit Values column. These values are the operator's input. The Edit Value Tag values are displayed until the table template is re-selected or when the page is first displayed. See the Input Value Expression section for more information.

## **Password Protection**

---

It is possible to lockout access to numeric entry unless the operator provides the correct password to the PanelMate unit. The selections available are None, A Only, B Only, or A or B. Protection is selected for the entire template and not the individual items. Password protection must be validated each time the table template is selected for numeric entry of an Edit Value field.

## **Table Entry Definition Table**

---

The Table Entry Definition Table allows you to configure up to 20 independent display/entry fields. Each item has a separate label, read value, and write value. Line 1 of the table corresponds to the first item, line 2 corresponds to the second, etc. The Sample Template displays only two items to assist in the layout of your text. To view a full online representation press <F7>. You can use the arrow keys on the full view page to scroll the items for test purposes.

The editor screen displays the first ten items. You can display the next five entries by pressing <F4> to scroll to the next page of entries. Use <F3> to scroll to the previous five entries.

It is not necessary to use all 20 items. When the PanelMate unit goes online the scroll will stop at the last completed entry. You may leave blank lines in the table and use lines for display purposes only.

## **Parameter Column**

---

The fields in this column accept up to 16 normal-size characters which is the descriptor for each individual table entry. Note that a 2WIDE template will only display 12 characters.

**Note** The parameter field information will only be stored to disk if there is a number in the Value Expression Column. For test purposes, a 1 may be entered in that column to cause the parameter text to be saved.

## **Value Expression Column**

---

This is the expression for the value that will be displayed in the field. This field accepts up to 45 characters.

The expression entered here may include a single PLC word or bit reference and a single factor of 10 scaling expression.

The following examples of expressions are shown using a generic format. Refer to the appropriate PLC chapter for more specific addressing formats.

[123]

The expression could be as simple a single word reference. This example references word 123.

[123]\*1000, [123]\*100, [123]\*10, [123]\*1, [123]\*.1, [123]\*.01, [123]\*.001

This is a mathematical expression that includes PLC references and a factor of 10 that will solve to a value.

## **Dec. Pt.**

---

Open this field and use the up/down cursor keys to select a value from 0-4. This value will position the decimal point for the Current Value field and the Edit Value field.

## **Target Word Address Column**

---

This field defines the location of the operator's input in the PLC. This field may include any mathematical expression that must be performed on the operator's input before the number is stored in the PLC. This field accepts up to 23 characters.

The target word address entered here may include a single PLC word or bit reference and a single factor of 10 scaling expression.

If an expression is defined for an individual entry, a small arrow will be displayed in the lower left corner of the template to indicate that numeric entry is available while the template is selected.

The following examples of expressions are shown using a generic format. Refer to the appropriate PLC chapter for more specific addressing formats.

[123]

The expression could be as simple a single word reference. This example references word 123.

[123]\*1000, [123]\*100, [123]\*10, [123]\*1, [123]\*.1, [123]\*.01, [123]\*.001

This is a mathematical expression that includes PLC references and a factor of 10 that will solve to a value.

## **Editing Existing Templates**

---

To edit an existing template, use the cursor arrow keys in the Page Editor - Template Mode to select the template to be edited and press <F1>. The Table Template Editor will immediately appear on the screen with the fields filled-in as you last saved them for the selected template.

## **Exit the Table Template Editor**

---

To exit the Table Template Editor and return to the Page Editor - Template Mode, press <F10>.

# **Gathering Information for Configuration**

---

Before beginning configuration, it will probably be useful to gather all the information you will need. The form provided on the following page may be reproduced and used to organize your data prior to entry into the PanelMate unit. When a form is completed, you will have gathered all the information you will need for this particular template.

### TABLE TEMPLATE EDITOR

Template Size 1 or 2 HIGH, 2 or 3 WIDE

Device Name (18/28 char):\_\_\_\_\_

Parameters Tag (12/16 char)\_\_\_\_\_

Current Value Tag (5 char)\_\_\_\_\_

Edit Value Tag (5 char)\_\_\_\_\_

Password Protection \_\_None \_\_A \_\_B \_\_A or B

### TABLE ENTRY DEFINITION TABLE

#	Parameters	Value Expression	Dec. Pt.	Target Word Address

# Chapter 21

## Maintenance Template Editor

---

In this chapter, you will learn:

- How Maintenance Templates can be used
- How to define a Maintenance Template
- How to edit existing Maintenance Templates
- How to return to the Page Editor

## Functions of Maintenance Templates

Maintenance Templates are designed to replace TCAM (timer/counter access module), DTAM (data table access module), and RAP (register access panel) devices that are typically used during setup and troubleshooting. For standard display of operator information, other templates should be configured for the operator. This display is meant to be used by a trained installation or maintenance technician who is knowledgeable in the addressing conventions of the PLC brand installed on the machine or process.

The single editor is used to define the startup characteristics of a Maintenance Template including read/write privileges, password protection, default PLC references, and default data formats. The following sections describe how each field in this editor relates to the template and what the appropriate field entries might be. The PanelMate unit will revert to the default values each time power is applied to the PanelMate unit. Refer to the figure below as needed. Once running online, an operator may change the PLC name, PLC reference, or the data format of the Maintenance Template.

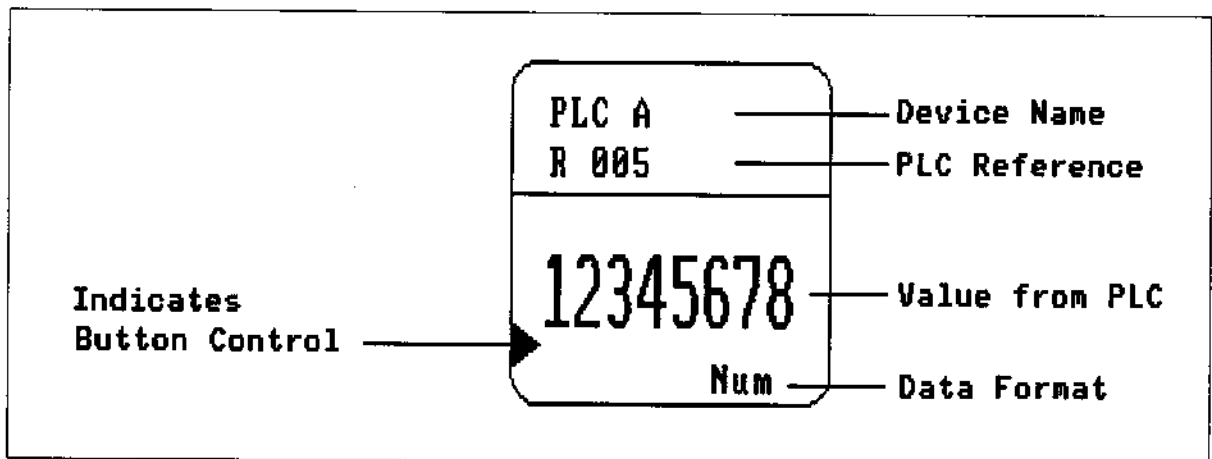


Figure 21-1 Maintenance Template

The following figure shows a representation of the Maintenance Template Editor. Each of the fields which compose this spreadsheet is reviewed in the following sections.

MAINTENANCE TEMPLATE EDITOR

PLC A  
R 885  
12345678

Template Size

Write privilege

Default PLC Reference

Data Format

Password Protection

Figure 21-2 Maintenance Template Editor

To edit a text field, cursor to the field and press <Return> to open the field. Type the text. Press <Return> to close the field or <Esc> to revert to the old value.

Other fields have Option Windows which pop-up on the screen. To edit this type of field, cursor to the field and press <Return>. Use the cursor keys to scroll through and highlight your selection. Press <Return> to accept the change or <Esc> to revert to the previous value.

Option Windows display all possible choices and will cursor over selections which are not permissible choices based upon your current configuration.

To exit the Maintenance Template Editor page, press <F10>.

## Template Size

---

The selections available are NORMAL or DOUBLE WIDE. Remember that for placing the template on the page, the cell cursor is always the left cell of a double-wide template.

## Write Privilege

---

This field determines if the operator can change the data or monitor the data. The selections available are READ/WRITE or READ ONLY. Make the proper selection based on expertise of operators and maintenance personnel.

**Note** The ability to change values (write) is very powerful and the operator should have complete knowledge of the PLC addressing conventions and complete machine or process control system before they are permitted to write information to the PLC.

## **Default PLC Reference**

---

Enter the PLC reference which will be displayed at startup and each time power is re-applied to the PanelMate unit. Refer to the appropriate PLC chapter for information regarding the format for specific PLC word references. The default PLC name does not need to be entered in this field. Any PLC listed in the PLC Name Table may be entered in this field.

## **Data Format**

---

The selections available are NUM, BITS, or HEX. If NUM is selected, the data will display in a numeric format. The PanelMate unit will automatically type cast information based upon the memory area of the PLC which is read. This means it will manage integer, BCD, and binary data types and display them as numbers. Numeric entries will be converted to the correct data type and sent to the PLC if the read/write privilege was chosen. If BITS is selected, the data is entered and will be displayed in a binary bit pattern for the register selected. The bit values will not be manipulated to any data format. The operator accepts responsibility for setting illegal bit combination. (For example, writing 1111 to a BCD digit is an illegal value.) If HEX is selected, the data is entered and will be displayed in hexadecimal format (0-9 and A-F) of the bit pattern for the register selected.

Sixteen bit values are displayed in four-digit HEX representation.

Example:       0023 HEX is written to the PLC as 0000 0000 0010 0011.

                  It is not converted to 35 decimal or 0000 0000 0100 0101 in binary.

Only NUM types are converted to the numeric value based upon the memory areas of the PLC referenced.

## **Password Protection**

---

It is possible to lockout access to numeric entry unless the operator provides the correct password. The selections available are None, A Only, B Only, or A or B. Password protection must be validated each time a template is selected for numeric entry.

## **Editing Existing Templates**

---

To edit an existing template, use the cursor arrow keys in the Page Editor - Template Mode to select the template to be edited and press <F1>. The Maintenance Template Editor will immediately appear on the screen with the fields filled in as you last saved them for the selected templates.

## **Exit the Maintenance Template Editor**

---

To exit the Maintenance Template Editor and return to the Page Editor - Template Mode, press <F10>.

## **Gathering Information for Configuration**

---

Before beginning configuration, it will probably be useful to gather all the information you will need. The form provided on the following page may be reproduced and used to organize your data prior to entry into the PanelMate unit. When a form is completed, you will have gathered all the information you will need for this particular template.

## MAINTENANCE TEMPLATE EDITOR

Template Size: NORMAL or DOUBLE-WIDE

Write privilege: READ/WRITE or READ ONLY

Default PLC Reference: \_\_\_\_\_

Data Format: NUM, BITS, or HEX

Password Protection    \_\_\_NONE    \_\_\_A    \_\_\_B    \_\_\_A or B

# Online Operation of the Maintenance Template

---

At power-up the Maintenance Template will display the default information configured using the template spreadsheet editor. The template will continuously update the display until the operator decides to make a change. Upon selecting the template, three control buttons will appear. The control buttons are labeled "Stop Monitor", "Change Value", and "Modify Template". Each control button is described below.

## Stop Monitor

---

This control button label will toggle between "Stop Monitor" and "Start Monitor". With this control button, it is possible to freeze a value for prolonged observation.

## Change Value

---

This control button will be displayed only if the read/write mode was configured for the template. This control button will change the display and open a data entry field to permit the operator to enter a value. If password protection has been used and is not enabled, the operator will be prompted before data entry is permitted.

## Modify Template

---

This control button is used to change the PLC address of the Maintenance Template. This control button will change the display and call another three control buttons to appear. The control buttons are labeled "Change PLC Name", "Change PLC Ref", and "Data Format". The operator may change any or all of the three entry variables (name, reference, format). Once you are satisfied with the changes, you must press the control button labeled "Start Monitor". This will advise the PanelMate unit to check the name, reference, and format to determine if they are valid, and if valid, begin to read that information.

If the reference is invalid, an error will be displayed on the error line on the bottom of the page and the template will be cleared.

The functionality of the three control buttons are defined in the following sections.

### Change PLC Name

The online selection of the PLC Name occurs in the bottom control button. The current value is displayed on the control button labeled "Accept". The operator may use the control buttons labeled "Previous" or "Next" to scroll through the list of names entered in the PLC Name and Port Table (see chapter 23 for details).

## Change PLC Ref

The online selection of the PLC Register Reference occurs in the reference field of the template. The operator must know the correct alpha and numeric characters to enter to access the memory of the PLC to which it is communicating. See your specific PLC Driver chapter in the Communications section for more information. If the PLC Brand uses numbers only, the numeric keypad may be used to enter the address. If the PLC brand requires characters other than numeric, then the four control buttons serve a very special purpose. The top two keys are used to determine the operation of the third key which becomes a "Hot Key". The functionality of the Hot Key can be changed by using the control buttons labeled "Previous" and "Next". The Hot Key can assume the following functionality:

Cursor Right	Move the entry cursor one character to the right
Cursor Left	Move the entry cursor one character to the left
Delete	Delete the character at the current cursor position
Space	Place a blank space at the current cursor position
Clear	Clear the entire entry field
Select	Enters the mode to select alpha character strings

Upon entering the Change PLC Reference mode, the Hot Key labeled "Clear" will be displayed. Selecting the control button labeled "Previous" will change the Hot Key to "Space", while selecting the control button labeled "Next" will change the Hot Key to "Select".

Upon entering the Select mode, the first of a list of alpha characters for the currently selected PLC Name will be displayed in the data entry field inside the bottom control button labeled "Accept". Selecting the control button labeled <Next> will move deeper into the alpha character list while selecting <Previous> would take you back to "Clear". Once in the Select mode, the <Previous> and <Next> keys will scroll through the alpha character strings that are required to address the PLC brand associated with the PLC Name currently selected. Once the correct character string is displayed, you may press the Hot Key labeled "Select" to lock in that character. Alternately, you may press a numeric key which will lock in the alpha key and enter a number. Pressing the numeric key will reduce the number of keystrokes and permit faster entry. Do not press the bottom control button labeled "Accept" until the entire address is entered or an error may occur.

The operator uses a combination of Hot Key entry and numeric entry to enter the address for the PLC. The Hot Key may also be used to edit an existing address without requiring complete re-entry of the address. See the following examples.

**Example 1: Entering a new address.**

To enter the Allen-Bradley Reference N7:10

- Select the Maintenance Template.
- Press the control button labeled "Modify Template".
- Press the control button labeled "Change PLC Ref".
- Press the control button labeled "Next". This will place the Hot Key in the Select mode.
- Press the control button labeled "Next". This displays a "B".
- Press the control button labeled "Next". This displays an "N".
- Press <7>. Use the numeric keypad.
- Press the control button labeled "Next" until the colon, ":", appears in the entry field.
- Press <1>, then press <0> to enter 10. Use the numeric keyboard.
- Press the bottom control button labeled "Accept" to enter the address.

As a final step, press the top control button labeled <Start Monitor> to begin reading that address.

**Example 2: Editing an existing field.**

To change the Allen-Bradley Reference N7:10 to N7:20

- Select the Maintenance Template
- Press the control button labeled "Modify Template".
- Press the control button labeled "Change PLC Ref". The cursor will appear at the far right of the entry field.
- Press the control button labeled "Previous". This will place the Hot Key in the Space mode.
- Press the control button labeled "Previous". This will place the Hot Key in the Delete mode.
- Press the control button labeled "Previous". This will place the Hot Key in the Cursor Left mode.
- Press the Hot Key labeled "Cursor Left". The Hot Key moves the cursor from the far right onto the 0.
- Press the Hot Key labeled "Cursor Left". The Hot Key moves the cursor from the 0 onto the 1.
- Press <2>. Use the numeric keypad. The "overstrike" replaces the 1. The value now reads N7:20.
- Press the bottom control button labeled "Accept" to enter the address.

As a final step, press the top control button labeled "Start Monitor" to begin reading that address.

## Data Format

The register can be formatted to display in one of the following choices: Num, Bits, or Hex. If you select Num, the data will be presented in a numeric format. The PanelMate unit will automatically type cast information based upon the memory area of the PLC which is read. This means it will manage integer, BCD, and binary data types and display them as numbers. Numeric entries will be converted to the correct data type and sent to the PLC if the read/write privilege was chosen. If you select Bits, the data will be displayed in a binary bit pattern for the register selected. If the PLC word contains 16 bits, then the display will show two 8 bit bytes. The sequence is high byte above low byte and high bit to the left, low bit to the right. If you select Hex, the data will be displayed in Hexadecimal format (0-9, A-F).

Figure 21-3 shows an example of a 16-bit word in a single-wide Maintenance Template with the Bits format selected.

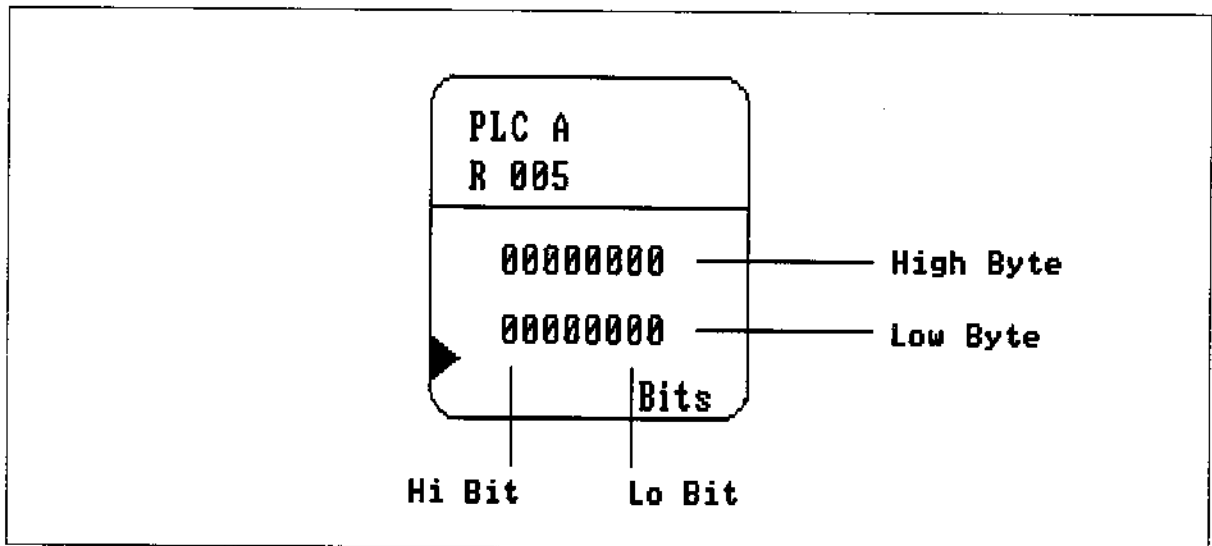


Figure 21-3 Maintenance Template

# Chapter 22

## Defining System Parameters

---

In this chapter, you will learn:

- How to select the page that will be displayed at power-up
- How to set the automatic cancel time interval
- How to select the password feature

# Edit System Parameters

This section allows you to edit general system parameters used during the online system's Run Mode. After making this selection from the Configuration Editor menu, the System Parameters Table will be displayed. It will look similar to figure 22-1.

SYSTEM PARAMETERS TABLE EDITOR				
F1=	F2=	F3=	F4=	F5=
F6=	F7=	F8=	F9=	F10=EXIT
Immediate Page Change	<input type="checkbox"/> N		Startup Page Number	<input type="checkbox"/> 8
Control Bit Reset	<input type="checkbox"/> 8 msec		Inactivity Period	
Bit Zero After Con Fault	<input type="checkbox"/> Y		Automatic Cancel	<input type="checkbox"/> 2 mins
Retry Delay	<input type="checkbox"/> Y		Audio Output	
Password A	<input type="text"/>		Operator Input	<input type="checkbox"/> ON
Password B	<input type="text"/>		Alarms	<input type="checkbox"/> ON
Remote Alarm (to PLC)	<input type="text"/>			
Acknowledge Bit (from PLC)	<input type="text"/>			
Page Change (to PLC)	<input type="text"/>			
Register (from PLC)	<input type="text"/>			
Remote Silence (to PLC)	<input type="text"/>			
Alarm Horn Bit (from PLC)	<input type="text"/>			

Figure 22-1 System Parameters Table

## Immediate Page Change

The Immediate Page Change field controls whether a PLC can change the displayed page (through the Page Change Register) while the PanelMate unit has a template selected. A "Y" entry will allow the page to change, even if the operator is in the process of entering information. An "N" entry will inhibit the page change until no template or element is selected (such as when the <CANCEL> key has been pressed). To change the setting, use the arrow keys to highlight the field. Press <Return> and the option window menu will display both choices. Use the arrow keys to highlight your choice, then press <Return> again.

## Control Bit Reset

The Control Bit Reset field controls the delay between the bit-set and bit-clear commands sent to a PLC from the control buttons. Control buttons can be pressed (causing a bit-set) and released (causing a bit-clear) very quickly. Some PLC programs need time to sense the bit-set command before receiving the bit-clear command. To change the setting, use the arrow keys to highlight the field. Press <Return> and the Control Bit Reset selection menu will display all the possible choices. Use the arrow keys to highlight your choice, then press <Return> again. The selections available are: 0, 250, 500, 750, or 1000 milliseconds.

## **Bit Zero After Com Fault**

---

The Bit Zero After Com Fault field provides the capability to reset (i.e., write zeroes to) all PLC bits configured in the PLC Bit Reference fields for each control button. The PLC bits will reset when a PLC communication error has been cleared (i.e., communication with the PLC has been re-established) and the control button labeled "Reset PLC Com" is pressed. A "Y" entry will enable the automatic reset of all PLC bits configured for control buttons. A "N" entry will disable the automatic reset of all PLC bits. To change the setting, use the arrow keys to highlight the field. Press <Return> and the option window menu will display both choices. Use the arrow keys to highlight your choice, then press <Return> again.

## **Retry Delay**

---

In the event of lost communications, the Retry Delay field defines how the PanelMate unit will attempt to re-establish communications to the PLC. With this field set to "Y", the PanelMate unit will increase the time interval of attempts to re-establish communications as the length of time that the PanelMate unit and PLC are not communicating increases. This selection prevents several PLCs on a network from becoming busy unnecessarily if communications have not taken place over a long period of time. With this field set to "N", the PanelMate unit will immediately and continuously attempt to re-establish communications. This will prevent any delays which may occur after successfully sending data to the PLC.

## **Passwords**

---

The Password A and B fields allow you to enter a PLC address which can be used to limit operator access to pages and templates during Run Mode. The Directory Editor, Bar Template, Readout Template, Table Template, and Maintenance Template control the assignment of password protection and passwords that will be used. A bit reference or word reference is permitted in this field. No expressions may be entered. If the value in the bit or word reference is zero, then the Password is disabled and access to a page is not permitted. If the value is non-zero, then the Password is enabled and access to a page or numeric entry is permitted. Leaving the fields blank will disable this feature. To enter an address, use the arrow keys to highlight the correct field. Press <Return> and enter the address you have chosen. Then press <Return> again to close the field.

## **Remote Alarm Acknowledge Bit**

---

The PanelMate unit can set a bit in a PLC when the control button Acknowledge All Alarms is pressed during Run Mode. This bit is defined in the field labeled "Remote Alarm Acknowledge Bit (to PLC)". The PanelMate unit can also scan a bit in a PLC and acknowledge all current alarms when the bit is set. This bit is defined in the field labeled "Remote Alarm Acknowledge Bit (from PLC)". Only bit references are permitted in these fields. No expressions may be entered. Leaving the fields blank will disable the features. To enter a bit address, use the arrow keys to highlight the correct field. Press <Return> and enter the address you have chosen. Then press <Return> again to close the field.

## **Page Change Register**

---

The PanelMate unit can write the number of its currently displayed page to a register in a PLC during Run Mode. Pages 0-7 use their page number. This register is defined in the field labeled "Page Change Register (to PLC)". The PanelMate unit can also scan a register in a PLC and change to the page number matching the register value. This register is defined in the field labeled "Page Change Register (from PLC)". When a new valid number has been received from the page change register, a cursor located to the right of the letter B in the System Overview field will blink. If a control template has been selected by the operator, the page will not change immediately. As soon as the control template is deselected, the page will change. (This requirement can be changed through use of the Immediate Page Change field on the first page of the System Parameters Table). Only register references are permitted in these fields. No expressions may be entered. Leaving the fields blank will disable the features. To enter a register address, use the arrow keys to highlight the correct field. Press <Return> and enter the address you have chosen. Then press <Return> again to close the field.

The Page Change Register will override Page Password Protection. In order to maintain the protection, use PLC ladder logic to implement a protection scheme.

## **Remote Silence Alarm Horn Bit**

---

The PanelMate unit can set a bit in a PLC when the control button, "Silence Alarm", is pressed during Run Mode. This bit is defined in the field labeled "Remote Silence Alarm Horn Bit (to PLC)". The PanelMate unit can also scan a bit in a PLC and silence the alarm horn when the bit is set. This bit is defined in the field labeled "Remote Silence Alarm Horn Bit (from PLC)". Only bit references are permitted in these fields. No expressions may be entered. Leaving the fields blank will disable the features. To enter a bit address, use the arrow keys to highlight the correct field. Press <Return> and enter the address you have chosen. Then press <Return> again to close the field.

## **Startup Page Number**

---

The Startup Page Number field allows you to choose which page will be displayed when the PanelMate online system first enters Run Mode. To change the page number, use the arrow keys to highlight the Startup Page Number field. Press <Return> and use the arrow keys to increase or decrease the number, then press <Return> again. The default for the startup page number is 0.

## **Inactivity Periods**

---

The Automatic Cancel field defines the time the PanelMate unit will wait with no operator inputs before de-selecting a template. This function helps prevent accidental usage of the ControlPanel when an operator leaves a template or element selected after use. To prevent this from occurring, the PanelMate unit will wait for the indicated number of minutes. Then, if no membrane keys were pressed during this time, the PanelMate unit will cancel selection of any template or element. The selections that are available are OFF and 1 to 20 minutes in 1 minute increments.

**Note** The Cancel generated by the timeout of the Automatic Cancel feature will reset the Screen Blanking timer.

To change an Inactivity Period time setting, use the arrow keys to highlight the correct Inactivity Period field. Press <Return> and a selection menu will display all the possible choices. Use the arrow keys to highlight your choice, then press <Return> again.

## **Audio Output**

---

The Operator Input field allows you to determine if audio feedback will be generated through the PanelMate unit's internal speaker. If you select "ON", tones will be generated. If you select "OFF", no sound will be generated. The Alarms field allows you to determine if an alarm tone will be generated each time there is a new alarm. If you select "ON", a tone will be generated if a new alarm occurs. If you select "OFF", a tone will not be generated if a new alarm occurs. Press <Return> and the Audio menu will display both choices. Use the arrow keys to highlight your choice, then press <Return> again.

## **Exit**

---

You can leave the System Parameters Table and return to the Configuration Editor menu by pressing the <F10> key.



# Chapter 23

## PLC Name and Port Parameters Table

---

In this chapter, you will learn:

- How to set the communications parameters for each port
- How to define the Default PLC Name
- How to set the scan rates for alarm conditions and updating the current pages

## Edit PLC Name and Port Table

This section allows you to set communication port parameters, PLC device names and ID numbers, and Allen-Bradley Remote I/O and DH-485 parameters. After making this selection from the Configuration Editor menu, the PLC Name and Port Editor will be displayed. It will look similar to figure 23-1.

**PLC NAME AND PORT EDITOR**

F1=                      F2=                      F3=                      F4=                      F5=  
 F6=                      F7=                      F8=                      F9=SAVE                F10=EXIT

VCP UNIT PORT PARAMETER TABLE

Port	Use	Network ID#	Data Bits	Stop Bits	Parity	Baud Rate	Elect.
1	A-B	0	8	1	None	9600	RS232

PLC NAME TABLE

Item	Name	ID#	Model
1	unit1	2	PLC-2 o
2		0	
3		0	
4		0	
5		0	
6		0	
7		0	
8		0	
9		0	
10		0	

Default PLC Name:

Screen Scan Delay:  sec

Alarm Scan Delay:  sec

Message Scan Delay:  sec

Figure 23-1 Port Parameter Table

### Use

Under the PLC Name and Port Editor, the Use field describes how the port will be used. To change the setting, use the arrow keys to highlight the field beside the port number you wish to use. Press <Return> and the Port Use menu will display all the possibilities (PLC type and None). Use the arrow keys or press the <home> and <end> keys to scroll through the menu and highlight your choice, then press <Return> again.

Note that DH-485, MOD-ASC, or MOD-RTU are also possible selections if you have the Data Highway 485 or Modicon Modbus option selected when creating the configuration. For more information on these options, see the appropriate PLC chapter in the Communications section of this manual.

To configure a DH-485 driver, the DH-485 option must be selected in the Port Parameter Table. Press the <F2> key labeled "Max Node" to call the Allen-Bradley Data Highway 485 Maximum Node Address Editor. See the Data Highway 485 section in this chapter for more information.

To configure the I/O port for Accelerati/On, move the cursor to port 1 and press <Return>. The Use field contains Data Highway, Data Highway Plus, and Remote I/O selections. When any of the above are selected, the port will change to I/O. See the Remote I/O Configuration section in this chapter for information regarding defining the Block Transfer Addressing, Active Rack Table, and Active Block Transfer Table. (Note that you must press <F2> to access the Remote I/O Configuration Editor.)

## **Network ID# (PanelMate Port Parameter)**

---

The Network ID# field sets the number assigned to the PanelMate unit on a PLC network. To change the number, use the arrow keys to highlight the field for Port 1. Press <Return> and enter the number. Then press <Return> again to close the field. See the appropriate PLC chapter for PLC Dependent network ID# information.

**Note** Do not use the same number for the PanelMate unit's network ID# and the PLC ID#.

## **Data Bits**

---

The Data Bits field sets the number of data bits used in serial communication. To change the setting, use the arrow keys to highlight the field for Port 1. Press <Return> and the Data Bits menu will display all the possibilities (5, 6, 7, and 8). Use the arrow keys to highlight your choice, then press <Return> again.

## **Stop Bits**

---

The Stop Bits field sets the number of stop bits used in serial communication. To change the setting, use the arrow keys to highlight the field for Port 1. Press <Return> and the Stop Bits menu will display all the possibilities (1, 1.5, and 2). Use the arrow keys to highlight your choice, then press <Return> again.

## **Parity**

---

The Parity field sets the parity type used in serial communication. To change the setting, use the arrow keys to highlight the field for Port 1. Press <Return> and the Parity menu will display all the possibilities (None, Odd, and Even). Use the arrow keys to highlight your choice, then press <Return> again.

## **Baud Rate**

---

The Baud Rate field sets the data transfer speed used in serial communication. To change the setting, use the arrow keys to highlight the field for Port 1. Press <Return> and the Baud Rate menu will display all the possibilities (110 to 38400). Use the arrow keys to highlight your choice, then press <Return> again. For "A-B Rem" selection of Accelerat/On, the choices are 57.6, 115.2, and 230.4 Kbaud.

**Note** The 38400 baud selection is not supported at this time.

## **Electrical (Elect.)**

---

The Elect. field sets the type of electrical communication standard to be used for communication. To change the setting, use the arrow keys to highlight the field for Port 1. Press <Return> and the Electrical menu will display all three possibilities (RS232, RS422, and 485-2). Use the arrow keys to highlight your choice, then press <Return> again. Note that the 485-2 selection is only available for DH-485.

## **Name**

---

Under the PLC Name Table, the Name fields define user-chosen names for each PLC to be addressed. You will use this name when specifying word and bit addresses during page development. To change the name, use the arrow keys to highlight the field you wish to use. Press <Return> and enter the name. Then press <Return> again to close the field.

## **ID# (PLC Name Table)**

---

The ID# fields set the number assigned to each PLC on a PLC network. To change the number, use the arrow keys to highlight the field beside the correct PLC name. Press <Return> and enter the number. Then press <Return> again to close the field.

**Note** Do not use the same number for the PanelMate unit's network ID# and the PLC ID#.

## **Model**

---

The Model fields define the model type of each PLC. Before changing this setting, make sure the Port field is set correctly. Then use the arrow keys to highlight the field for the PLC name you wish to use. Press <Return> and the PLC model menu will display all the possibilities for that PLC type. Use the arrow keys to highlight your choice, then press <Return> again.

## **Default PLC Name Field**

---

The Default PLC Name field will contain one of the PLC names entered by you in the list at the left of the screen. Any word or bit address used in the configuration which does not specifically state the name of a PLC will be assumed to be referring to this default PLC. It is to your advantage to use the name of the PLC most often referenced. To change the name, use the arrow keys to highlight the field and press <Return>. The Default PLC Name menu will display all the currently-entered PLC names. Use the arrow keys to highlight your choice, then press <Return> again.

**Note** You must have a default PLC Name in order to create a configuration.

## **Screen Scan Delay**

---

The Screen Scan Delay field sets the time delay between updates of a page when in Run Mode. An entry of 0 will cause the PanelMate unit to update a page as fast as possible. The maximum entry is 99.9 seconds. To change the number, use the arrow keys to highlight the field. Press <Return> and enter the delay time you want. Then press <Return> again to close the field.

## **Alarm Scan Delay**

---

The Alarm Scan Delay field sets the time delay between updates of all alarm conditions not shown in the current page when in Run Mode. An entry of 0 will cause the PanelMate unit to update these background alarms as fast as possible. The maximum entry is 99.9 seconds. For best performance, set this time to the longest interval your application will permit. A minimum of 1.0 second is recommended. To change the number, use the arrow keys to highlight the field. Press <Return> and enter the delay time you want. Then press <Return> again to close the field.

## **Message Scan Delay**

---

The Message Scan Delay field sets the time delay between updates of all register references defined in messages when in Run Mode. An entry of 0 will cause the PanelMate unit to update the register values as fast as possible. The maximum entry is 99.9 seconds. For best performance, set this time to the longest interval your application will permit. A minimum of 1.0 second is recommended. To change the number, use the arrow keys to highlight the field. Press <Return> and enter the delay time you want. Then press <Return> again to close the field.

# Remote I/O Configuration

Accelerat/On allows the PanelMate unit to simulate one or more remote racks. The PLC communicates to the Accelerat/On interface as though the interface is a rack. For more information, see Chapter 30, The Accelerat/On Interface.

To configure the I/O port for remote I/O, move the cursor to port 1 and press <Return>. Choose Remote I/O from the Use field selections. An additional function key will be displayed while the cursor is on the I/O port Use field. Press <F2> to access the Remote I/O Configuration Editor. The PLC model will appear at the top of the screen. The number of racks available is dependent on the PLC model configured. This Remote I/O Configuration Editor is divided into two sections, the Active Rack Table and the Active Block Transfer Table. Refer to the figure below.

**Note** When configuring the I/O port for Remote I/O, select the PLC-3 model for PLCs with more than seven racks. PLC models (i.e., PLC 5/40 and PLC 5/60) that have more than seven racks must use the PLC-3 model selection to address racks above seven.

The following sections describe the function of each field.

ALLEN-BRADLEY REMOTE I/O CONFIGURATION							
F1=	F2=	F3=	F4=	F5=			
F6=	F7=	F8=	F9=	F10=EXIT			
PLC Model: PLC5/15							
ACTIVE RACK TABLE			ACTIVE BLOCK TRANSFER TABLE				
#	1234	Transfer	Direct	Rack	Group	Slot	Size
1	3*	A	COMMON	1	2	0	64
2	2*	B	READ	1	3	1	64
3	1---	C	WRITE	1	4	0	64
		D	COMMON	1	5	1	64
		E	READ	1	6	0	64
		F	WRITE	1	7	1	64
		G	PASS	2	0	0	64
		H	WRITE	2	1	1	10
		I					
		J					
		K					
		L					
		M					
		N					
		O					
		P					

Figure 23-2 Remote I/O Configuration Editor

## Active Rack Table

---

The Active Rack Table allows you to define which racks are to be simulated by the PanelMate unit on the network. Each full rack can be split into a quarter rack or any multiple of a quarter racks (i.e., 1/4, 1/2, 3/4, or full rack). A blank field is the default value and shows that the quarter rack is inactive. A status of 1, 2, 3, or 4 implies the quarter rack is active and indicates the starting quarter for a fractional rack. An asterisk, \*, is contained in the other quarter racks which make up a fractional rack. For example, if you configured a half rack to start on the second quarter of rack 1, a 2 would appear in the second quarter space for rack 1 and an asterisk would appear in the third quarter space as a place holder. Figure 23-2 shows an example of the PanelMate unit simulating 3/4 of rack 1, 1/2 of rack 2, and 1/4 of rack 3. A status of 1 denotes 1/4 rack, 2 denotes 1/2 rack, 3 denotes 3/4 rack and 4 denotes a full rack.

**Note** When using a PLC 2/30 and the PanelMate unit is configured as active groups within a rack other than the highest group, then the PLC will not scan for any groups higher than those the PanelMate unit is simulating (physical groups or groups simulated on another Acceleratl/On board). To avoid this situation, make the PanelMate unit the highest active group within a rack and only configure one PanelMate unit active on any one rack.

## Active Block Transfer Table

---

The Active Block Transfer Table will allow you to configure active block transfers between the PanelMate unit and a PLC. You may define up to 16 active block transfers, A through P, each with up to 64 words.

**Note** All numbers used for PLC addressing in remote I/O references are in octal.

### Direct

This column defines the direction of the block transfer. The available selections are NONE, READ, WRITE, and COMMON. All of the selections describe communication from the PLC's point of view. The READ selection allows the PLC to read a block of data from the PanelMate unit. The WRITE selection allows the PLC to write a block of data to the PanelMate unit. The COMMON selection allows the PLC to both read data from and write data to the PanelMate unit.

### Rack

This column defines the rack being used by the block transfer. The available selections are determined by the Active Rack Table. This field will scroll through only the active racks in the table.

### Group

This column defines the group number within the quarter rack being used by the block transfer. The selections available are 0, 1, 2, 3, 4, 5, 6, and 7.

### Slot

This column defines the slot number within the group being used by the block transfer. The available selections are 0 and 1.

### Size

The column defines the size in 16-bit words of the block transfer. The available selections are decimal numbers from 1 to 64.

### Exit <F10>

Press <F10> to exit and return to the PLC Name and Port Editor.

## Data Highway 485

---

Most Data Highway 485 (DH-485) devices have a parameter which sets the maximum node address. The maximum node address should be set as low as possible. This minimizes the amount of time used in soliciting data when initializing the link and when finding new data when token passes do not receive a response.

**Note** The Maximum Node Address (set in the second page of the PLC Name and Port Table) must match the actual maximum node address on the Data Highway 485.

In order to configure a DH-485 driver, the DH-485 option must have been selected in the Use field of the Port Parameter Table. Press the <F2> key labeled "Max Node" to call the Allen-Bradley Data Highway 485 Maximum Node Address Editor. Open the field by pressing <Return>, then use your arrow keys to select the maximum node address.

For more information about Data Highway 485, refer to Chapter 29, Allen-Bradley PLCs.

ALLEN-BRADLEY DATA HIGHWAY 485 MAXIMUM NODE ADDRESS EDITOR				
F1= F6=	F2= F7=	F3= F8=	F4= F9=	F5= F10=EXIT
Maximum Node Address				
31				

Figure 23-3 Maximum Node Address Editor

# Chapter 24

## System Online Labels Editor

---

In this chapter, you will learn:

- How to define Online Labels

## **System Online Labels (Online Label Alternatives)**

---

This utility will allow you to change the labeling used on most of the PanelMate unit screens to any one of the normal font characters including the International Font.

This utility contains six screens for changing the labels. A menu at the top of each screen describes the use of the function keys. The following is a list of each function key and its use.

F3	Display previous screen.
F4	Display next screen.
F9	Save the system labels file to a temporary directory without exiting the System Online Labels Editor.
F10	Exit the System Online Labels Editor with optionally saving the system labels file.

The first screen will allow you to select the startup label set (standard or user) and to allow the label set to be changed during online operation.

### **Startup Online Labels**

This field allows you to select the label set to be used at startup. The selections available in this field are STANDARD or USER. If STANDARD is selected, the PanelMate unit will use the label set shipped with the unit when going online. If USER is selected, the PanelMate unit will use the label set you have created when going online.

Use <Return> to open the field, cursor keys to select, and <Return> to close.

### **Change Labels Online**

This field allows you to select whether or not the operator will be permitted to change the label set during online operation. If you select "Y" for this field, a control button labeled "Change Online Labels" will appear when the <Get Page> control button is pressed. This button will toggle between using the standard and user selected fonts. The selections available in this field are Y or N.

Use <Return> to open the field, cursor keys to select, and <Return> to close.

## **Miscellaneous Soft Key Prompts 1**

---

This screen will allow you to redefine the following labels.

- Change Labels
- View/Ack Alarms
- Get Page
- Scroll Up
- Scroll Down
- Ack Alarm
- Ack All Alarms
- Alarm Page
- Silence Alarm
- Reset PLC Com

## **Miscellaneous Soft Key Prompts 2**

---

This screen will allow you to redefine the following labels.

- Change Value
- Clear
- Home
- Select Entry
- Return & Select
- Adjust Contrast
- Lighter
- Darker
- Save Setting
- Enter:

## **Maintenance Template Soft Key Prompts**

---

This screen will allow you to redefine the following labels.

Modify Template  
START MONITOR  
Change PLC Name  
Change PLC Ref  
Data Format  
Next  
Previous  
Accept  
STOP MONITOR  
Return  
Delete  
Cursor Right  
Cursor Left  
Space  
Select  
High Byte  
Low Byte

## **Error Messages**

---

This screen will allow you to redefine the following labels.

Invalid Entry  
P/W A DISABLED  
P/W B DISABLED  
P/W A/B DISABLED

## **Miscellaneous Text**

---

This screen will allow you to redefine the following labels.

ALARM PAGE

CONTROL

Enter Page #

## **Alarm Text**

---

This screen will allow you to redefine the following labels.

CIRD

ACKD

LOW ALARM

HIGH ALARM



# Chapter 25

## Print Documentation

---

In this chapter, you will learn:

- How to print system configuration documentation

# Print Documentation

Print Documentation will print all pertinent information for a User Configuration, including:

- Directory Editor Page
- Individual Page Layouts
- Templates
- PLC Name and Port Table
- System Parameters
- Message Library
- Symbol Library
- System Online Labels

All documentation or individual area can be selected and automatically printed by the Configuration Software Package.

**Note** Print Documentation will not support printing the International Font characters except in the Font printouts. International Font Characters will be printed as asterisks (\*) for all other printouts including page layouts, templates, and the Message Library.

If you selected File as the Documentation Device in the Utility Parameters Editor, the following screen will appear so you may specify the print documentation filename. You may type the filename you prefer or press <F1> to select an existing filename. The Documentation Menu will then appear.

**PRINT DOCUMENTATION**

F1=SELECT	F2=	F3=	F4=	F5=
F6=	F7=	F8=	F9=	F10=

Print Documentation Filename

Do not include the file extension.

Directory: C:\VCP\ONLINE\print\

PRINT1.TXT	PRINT2.TXT	PRINT3.TXT	PRINT4.TXT
------------	------------	------------	------------

Figure 25-1 Print Documentation Screen

**Note** If you select additional component files after the initial print to file, subsequent prints will be appended to the print file as long as you do not exit the Documentation Menu.

To change the directory where your file will be placed, you must change the Documentaton Directory field on the second page of the Utility Parameters Editor. For more information, refer to the Edit Utility Parameters section in Chapter 11.

If you selected a parallel or serial port as the Documentation Device in the Utility Parameters Editor, the Documentation Menu will appear.

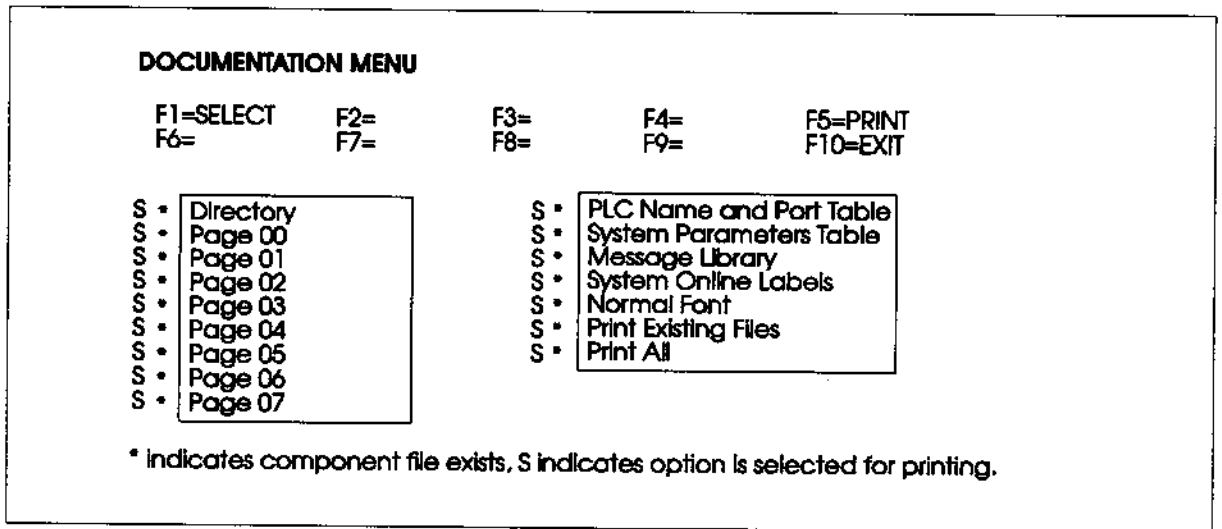


Figure 25-2 Print Documentation Menu

Use the arrow keys to cursor select a desired component file, then press <F1> to select the file. Once all desired component files are selected, press <F5> to begin printing.

The printer setup is performed in the Edit Utility Parameters Editor described in Chapter 11.

**Note** Print Documentation is available only to printers connected directly to your personal computer. Print Documentation will not operate with a networked printer.



# Chapter 26

## Transfer Editor

---

In this chapter, you will learn:

- The features of the Transfer Editor
- How to connect to an online unit for transfer
- How to upload or download a configuration
- How to download a driver
- How to download an option
- How to read system configuration information

## Overview

---

The Transfer Editor in the DOS-based Transfer Information Software Package is used to upload and download the memory of the PanelMate online system using the serial port. The PanelMate online system uses non-volatile FLASH memory. This memory is segmented into two main areas: Drivers and User Configuration. The PanelMate unit also reserves memory to store options such as the Allen-Bradley DH-485 Option and Modicon Modbus Option.

**Note** The terms upload and download are defined based on the view from the DOS-based personal computer. Therefore software is downloaded from the personal computer to the PanelMate unit and uploaded from the PanelMate unit to the personal computer.

**Note** The PanelMate unit must be in the Offline Mode to use the Transfer Utility.

The Driver Firmware is the base firmware of the PanelMate unit. It contains the operating system and all the software which comprise the online functionality. You can upgrade a PanelMate unit by downloading new Driver Firmware without having to ship the unit back to Cutler-Hammer IDT. You can only download Driver Firmware, you cannot upload it.

The User Configuration memory is where you store your configuration. The PanelMate unit has 8 pages of memory. You can upload and download User Configurations.

The Transfer Utility is also used to install options in the PanelMate online system. You must purchase the options separately. Options include the Allen-Bradley Data Highway 485 driver and the Modicon Modbus driver. Once an option is installed, it cannot be removed.

**Note** Options can only be installed in the PanelMate unit. There is no way to de-install (remove) an option.

**Note** Options should be installed before downloading the PLC driver.

**Note** During installation of an option, the associated PLC driver is also downloaded.

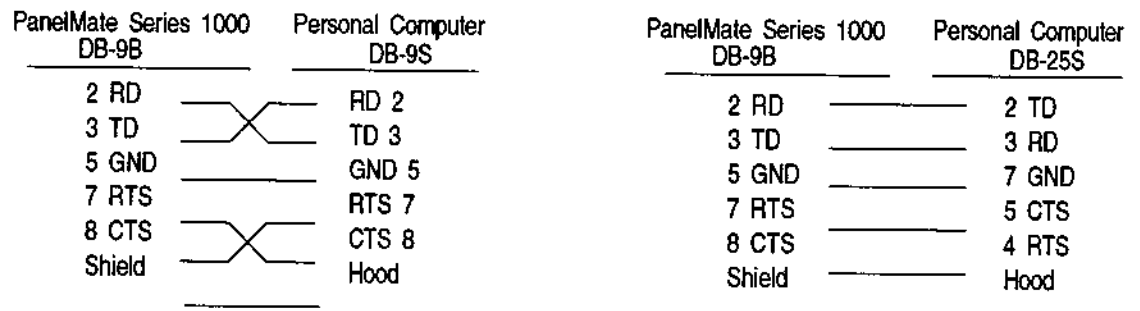
# Preparing to Transfer

To use the Transfer Utility, three steps must be performed.

- The PanelMate online unit must be placed in the Transfer Mode.
- The DOS-based personal computer must be connected via an upload/download cable to the PanelMate system.
- The Transfer Editor in the software must be invoked.

The PanelMate unit must be placed in the Transfer Mode. If the unit is online, an orderly shutdown must be executed. Re-apply power to the PanelMate unit and immediately press and hold the <Cancel> key until the Offline Mode is entered. Then select the Transfer Mode and press the control button labeled "Execute".

The DOS-based personal computer must be connected via an upload/download cable to the PanelMate unit. The default value for the DOS-based software is to use the first available serial port (usually COM1) of the personal computer. A different port may be selected from the Utility Parameters Editor. The personal computer must be connected to the serial port on the PanelMate unit. You may use the upload/download cable which can be optionally purchased from Cutler-Hammer IDT to make this connection. This accessory is a 6 foot cable which connects between the 9-pin D-shell connectors of the two units. The accessory package also contains a 25-pin to 9-pin adapter in case your personal computer has a 25-pin port.



**Figure 26-1 Serial Transfer Cable**

The final step is to enter the Transfer Editor on the DOS-based personal computer. Once the PanelMate unit is placed in the Transfer Mode all control is performed from the personal computer. Simply make the desired selection and follow the instructions.

**Note** You may change the default communication rate from 9600 baud to a higher baud rate.

**Note** To verify cabling and communications between your DOS-based personal computer and the PanelMate online unit, choose the "Read System Information from the VCP unit" selection from the Transfer Information Menu. This selection will verify that communications are working properly.

# The Transfer Information Menu

---

The Transfer Information Menu contains a selection named Transfer Information. Choosing this selection causes the Transfer Information Menu to appear as shown below. This menu contains seven options. The following sections will give a brief description of each selection.

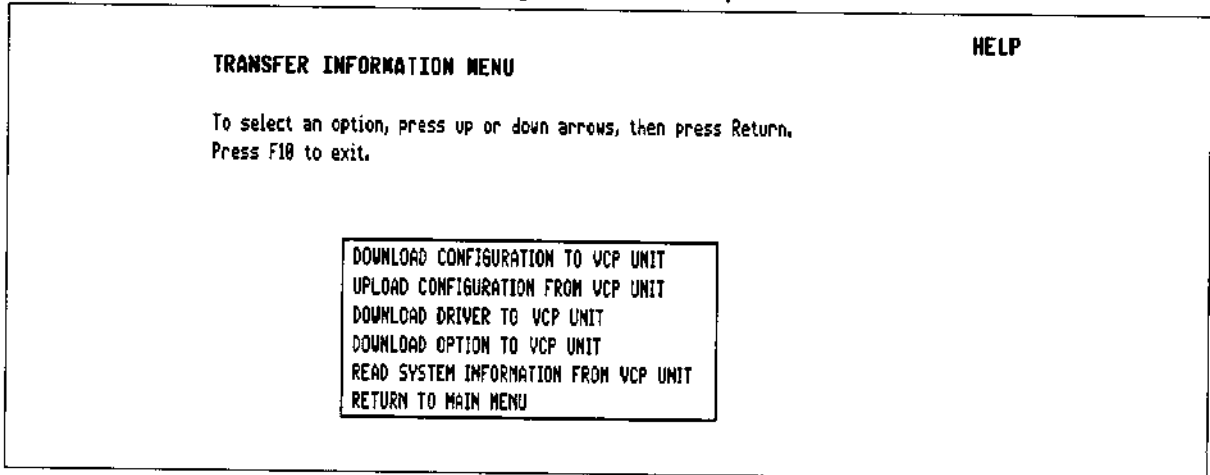


Figure 26-2 Transfer Information Menu

## Download Configuration to VCP Unit

---

This selection allows you to transfer a configuration from the development computer to the PanelMate online system. The configuration will include system parameters, PLC connection information and display pages containing templates, elements, and static text.

**Note** The PanelMate online system must be loaded with options and Driver Firmware before it can receive a configuration.

After choosing this option, the Transfer Editor will display a list of the configuration files presently in the Configuration directory specified in the Utility Parameters Editor and available for transfer. You may select a file by typing its name (including extension) and pressing <Return>. You may also press the <F1> key which will highlight a name in the displayed list. With this method, use the arrow keys to move the highlight to a desired name and press <Return> to select it.

After selecting the configuration name, the Transfer Editor will display a status screen similar to figure 26-3.

TRANSFER EDITOR - DOWNLOAD CONFIGURATION				
F1=START	F2=9600	F3=19200	F4=	F5=
F6=	F7=	F8=	F9=	F10=EXIT

Press F1 to download the configuration, F2 or F3 to change the baud rate or F10 to exit.

Bytes Transmitted To VCP Unit:

Configuration Name:

Product:

Version:

Bytes To Transfer:

Communication Port:

Baud Rate:

Figure 26-3 Transfer Editor - Download Configuration

The Product field displays the PanelMate Series 1000 product name.

The Version field shows the PanelMate software version of the stored configuration. The Communication Port field shows the number of the serial port to be used (1=COM1, 2=COM2, etc.). If you wish to use a different baud rate from the one displayed, connect to the online unit which is in the Transfer Mode, then press <F2> to choose the 9600 baud rate or press <F3> to choose the 19200 baud rate.

After the development computer has been properly connected to the PanelMate online system, and the online system has been set to receive a configuration, press <F1> to begin the transfer. The Transfer Editor will count the number of bytes successfully transferred to the online system. The Transfer Editor will notify you when the transfer is complete.

During normal operation, the screen will display the following status or error messages during the transfer:

PLEASE WAIT...WAITING FOR VCP UNIT WRITE CONFIRMATION.

After the configuration has been transferred, the Transfer Editor will wait for an acknowledgment from the online system. The following message will be displayed:

CONFIGURATION SUCCESSFULLY DOWNLOADED. PRESS ANY KEY TO CONTINUE.

After a wait of one minute with no acknowledgment, the Transfer Editor will allow you to abort the wait by pressing the <F10> key.

## Download Configuration Error Messages

In the event of an error, one of the following messages will be displayed:

CONFIGURATION COULD NOT BE DOWNLOADED DUE TO DATA TRANSFER ERRORS.

- Errors occurred during serial communication between the development computer and the online system.

CONFIGURATION COULD NOT BE WRITTEN TO VCP UNIT MEMORY.

- Write errors occurred in the online system's non-volatile memory.

CONFIGURATION COULD NOT BE DOWNLOADED. PRESS ANY KEY TO CONTINUE.

TRANSFER ABORTED. PRESS ANY KEY TO CONTINUE.

USER ABORTED THE TRANSFER. PRESS ANY KEY TO CONTINUE.

- You pressed the <F10> key to stop the transfer.

VCP UNIT DRIVER FIRMWARE INCOMPLETE. RELOAD DRIVER FIRMWARE.  
CONFIGURATION IS NOT COMPATIBLE WITH THE DRIVER FIRMWARE VERSION.

- The configuration file being transferred was created with a different software version of the PanelMate unit than the Driver Firmware that has been loaded.

MODICON MODBUS OPTION IS NOT INSTALLED ON VCP UNIT.

- The configuration file being transferred was created using the Modicon Modbus option. The online system does not contain this option.

DH-485 OPTION IS NOT INSTALLED ON VCP UNIT.

- The configuration file being transferred was created using the DH-485 option. The online system does not contain this option.

The <F10> key will return to the Transfer Information Menu.

## Upload Configuration from VCP Unit

This selection allows you to transfer a configuration from the PanelMate online system to the development computer and store it.

After choosing this selection, the Transfer Editor will display a list of the configuration files presently in the Configuration directory specified in the Utility Parameters Editor. You may select a file name for storage of the configuration by typing it (including extension) and pressing <Return>. You may also press the <F1> key which will highlight a name in the displayed list. With this method, use the arrow keys to move the highlight to a desired name and press <Return> to select it. If you choose an existing name, you will overwrite the configuration currently stored under that name. When uploading a configuration from a PanelMate unit, you must use the .PC0 filename extension.

After you select the file name, the Transfer Editor will display the a status screen similar to figure 26-4.

TRANSFER EDITOR - UPLOAD CONFIGURATION				
F1=START	F2=9600	F3=19200	F4=	F5=
F6=	F7=	F8=	F9=	F10=EXIT

Press F1 to upload the configuration, F2 or F3 to change the baud rate or F10 to exit.

Bytes Received From VCP Unit:

Configuration Name:

Product:

Version:

Expected File Size:

Communication Port:

Baud Rate:

Figure 26-4 Transfer Editor - Upload Configuration

The Product field displays the PanelMate Series 1000 product name.

The Version field shows the PanelMate software version of the configuration being received. The Communication Port field shows the number of the serial port to be used (1=COM1, 2=COM2, etc.). If you wish to use a different baud rate from the one displayed, connect to the online unit in the Transfer Mode, then press <F2> to choose the 9600 baud rate or press <F3> to choose the 19200 baud rate.

After the development computer has been properly connected to a PanelMate online system, and the online system is ready to transfer a configuration, press <F1>. The Transfer Editor is now ready to receive. You may start the transfer from the online system. The Transfer Editor will count the number of bytes successfully received. It will notify you when the transfer is complete.

During normal operation, the screen will display the following status messages during the transfer:

CONFIGURATION SUCCESSFULLY UPLOADED. PRESS ANY KEY TO CONTINUE.

### Upload Configuration Error Messages

In the event of an error, one of the following messages will be displayed:

CONFIGURATION COULD NOT BE UPLOADED DUE TO DATA TRANSFER ERRORS.

- Errors occurred during serial communication between the development computer and the online system.

CONFIGURATION COULD NOT BE SAVED TO DISK.

CONFIGURATION COULD NOT BE UPLOADED. PRESS ANY KEY TO CONTINUE.

TRANSFER ABORTED. PRESS ANY KEY TO CONTINUE.

USER ABORTED THE TRANSFER. PRESS ANY KEY TO CONTINUE.

- You pressed the <F10> key to stop the transfer.

INVALID FILE EXTENSION. YOU MUST CHANGE THE FILE EXTENSION TO <extension>.

- The correct filename extension, .PC0, must be used when uploading a configuration.

The < F10> key will return to the Transfer Information Menu.

## Download Driver Firmware to VCP Unit

---

This selection allows you to transfer a driver from the development computer to the PanelMate online system. An online system must contain this driver to communicate to an outside device, such as a PLC.

After choosing this selection, the Transfer Editor will display a list of the downloadable driver files presently in the Driver directory specified in the Utility Parameters Editor and available for transfer. You may select a file by typing its name (no extension) and pressing <Return>. You may also press the <F1> key which will highlight a name in the displayed list. With this method, use the arrow keys to move the highlight to a desired name and press <Return> to select it.

The software can have up to 22 drivers if optional drivers are included. The abbreviations, which appear in the Use field of the PLC Name and Port Editor, the driver name, and the DOS-filenames, are listed below.

<u>Use</u>	<u>Name</u>	<u>DOS filename</u>
A-B	Allen-Bradley Serial	AB.DR
DH-485*	Allen-Bradley Data Highway 485	ABDH485.DR
DHWAY	Allen-Bradley Data Highway	ABDH.DR
DHWAY+	Allen-Bradley Data Highway Plus	ABDH.DR
A-B REM	Allen-Bradley Remote I/O	ABREM.DR
EATON	Cutler-Hammer	EATON.DR
GE P/P	General Electric Peer-to-Peer	GE.DR
GE M/S	General Electric Master/Slave	GE.DR
GE S90P	General Electric Series 90 Point-to-Point	GES90P.DR
GE S90N	General Electric Series 90 Network	GES90.DR
MITS	Mitsubishi A Series	MITS.DR
MITS-FX	Mitsubishi FX Series	MITSFX.DR
MOD-ASC*	Modicon ASCII	MODICON.DR
MOD-RTU*	Modicon RTU	MODRTU.DR
OMRON	Omron Host Link	OMRON.DR
REL	Reliance	RELIANCE.DR
SIEMENS	Siemens	SIEMENS.DR
SquareD	Square D	SQUARED.DR
TI	Texas Instruments	TI.DR
TI-HL/P	Texas Instruments Hostlink Peer-to-Peer	TIHL.DR
TI-HL/M	Texas Instruments Hostlink Master/Slave	TIHL.DR
WEST	Westinghouse	WEST.DR

- \* **Note** The Allen-Bradley Data Highway 485 and the Modicon ASCII and RTU drivers require option diskettes which are purchased separately and must be installed in the PanelMate unit before the driver can be downloaded. To reduce download time, install the option before you install the driver. During the installation of the option, you will be prompted to install the driver.

If the downloadable driver file is found to be corrupt, the following message will be displayed:

```
INVALID DOWNLOADABLE DRIVER FILE <file>.
```

After selecting the downloadable driver filename, the Transfer Editor will display a status screen similar to figure 26-5.

TRANSFER EDITOR - DOWNLOAD DRIVER				
F1=START	F2=9600	F3=19200	F4=	F5=
F6=	F7=	F8=	F9=	F10=EXIT

Press F1 to download the Downloadable Driver, F2 or F3 to change the baud rate or F10 to exit.

Bytes Transmitted To VCP Unit:

Downloadable Driver Name:

Version:

Bytes To Transfer:

Communication Port:

Baud Rate:

Figure 26-5 Transfer Editor - Download Driver

The Version field shows the PanelMate software version of the driver to be transferred. The Communication Port field shows the number of the serial port to be used (1=COM1, 2=COM2, etc.). If you wish to use a different baud rate from the one displayed, press <F2> to choose the 9600 baud rate or press <F3> to choose the 19200 baud rate.

After the development computer has been properly connected to the PanelMate online system, and the online system has been set to receive a downloadable driver file, press <F1> to begin the transfer. The Transfer Editor will count the number of bytes successfully transferred to the online system. The Transfer Editor will notify you when the transfer is complete.

During normal operation, the screen will display the following status or error message during the transfer:

```
PLEASE WAIT...WAITING FOR VCP UNIT WRITE CONFIRMATION.
```

After the downloadable driver has been transferred, the Transfer Editor will wait for an acknowledgment from the online system. The following message will be displayed:

```
DOWNLOADABLE DRIVER SUCCESSFULLY DOWNLOADED. PRESS ANY KEY TO CONTINUE.
```

After a wait of one minute with no acknowledgment, the Transfer Editor will allow you to abort the wait by pressing the <F10> key.

## Download Driver Error Messages

In the event of an error, one of the following messages will be displayed:

DOWNLOADABLE DRIVER VERSION IN VCP UNIT IS THE SAME VERSION AS TO BE DOWNLOADED. DO YOU WISH TO CONTINUE? PRESS Y OR N.

USER CONFIGURATION <filename> IN VCP UNIT WILL BE INVALID. DO YOU WISH TO CONTINUE? PRESS Y OR N.

THE LAST EXECUTIVE FIRMWARE SEGMENT WILL BE ERASED AND WRITTEN BACK TO MEMORY. DO YOU WISH TO CONTINUE? PRESS Y OR N.

CANNOT FIND EXECUTIVE FIRMWARE FOR POSSIBLE DOWNLOAD TO VCP UNIT. DO YOU WISH TO CONTINUE? PRESS Y OR N.

DOWNLOADABLE DRIVER COULD NOT BE DOWNLOADED DUE TO DATA TRANSFER ERRORS.

- Errors occurred during serial communication between the development computer and the online system.

DOWNLOADABLE DRIVER COULD NOT BE WRITTEN TO VCP UNIT MEMORY.

- Write errors occurred in the online system's non-volatile memory.

DOWNLOADABLE DRIVER COULD NOT BE DOWNLOADED. PRESS ANY KEY TO CONTINUE.

TRANSFER ABORTED. PRESS ANY KEY TO CONTINUE.

USER ABORTED THE TRANSFER. PRESS ANY KEY TO CONTINUE.

- You pressed the <F10> key to stop the transfer.

## Download Option to VCP Unit

This selection allows you to transfer an optional function from your development computer's floppy disk to the PanelMate online system. Optional functions for the PanelMate Series 1000 are the Allen-Bradley Data Highway 485 driver and the Modicon Modbus ASCII and RTU drivers. The installation process loads the option and the appropriate downloadable driver in one step. Before downloading an option, you must ensure that the appropriate downloadable driver is installed on the development computer's hard disk in the downloadable driver directory.

TRANSFER EDITOR - DOWNLOAD OPTION				
F1=START	F2=9600	F3=19200	F4=	F5=
F6=	F7=	F8=	F9=	F10=EXIT

Press F1 to download the Option and Downloadable Driver,  
F2 or F3 to change the baud rate, or F10 to exit.

Bytes Transmitted To VCP Unit:

OPTION

Option:

License Type:

Number of Option Installations Available on Diskette:

Option Installation Diskette Drive:

DOWNLOADABLE DRIVER

Downloadable Driver Name:

Version:

Bytes to Transfer:

Communication Port:

Baud Rate:

Figure 26-6 Transfer Editor - Download Option

To install an option, insert the option diskette in the floppy driver. (The default diskette drive is drive A. To change this selection, exit out to the Main Menu and choose the Edit Utility Parameters selection. Complete details are found in Chapter 11, The Main Menu.)

For a quicker download, change the baud rate to 19200 by pressing <F3>. Press <F1> to start the download. The Option field will display the option which is read from the diskette and begin the download process. Follow all prompts and the download process will install both the option and the downloadable driver in one step. The Transfer Editor will notify you when the transfer is complete.

The Transfer Editor will notify you when the transfer is complete.

```
<option name> OPTION SUCCESSFULLY INSTALLED. PRESS ANY KEY TO  
CONTINUE.
```

The option will be removed from the installation diskette.

## Download Option Errors

In the event of an error, one of the following messages will be displayed:

<Option name> OPTION COULD NOT BE INSTALLED.

COULD NOT FIND OPTION ON DISKETTE. PLEASE INSERT OPTION DISKETTE. PRESS ANY KEY TO CONTINUE OR F10 TO EXIT.

- The option file could not be found or a diskette is not in the drive.

INVALID OPTION FILE. PLEASE INSERT OPTION DISKETTE. PRESS ANY KEY TO CONTINUE OR F10 TO EXIT.

- The option file is corrupt.

INSTALL OPTION NOT AVAILABLE. PLEASE INSERT ANOTHER OPTION DISK. PRESS ANY KEY TO CONTINUE OR F10 TO EXIT.

- The option has a single license and it has already been used.

OPTION <optionname> ALREADY INSTALLED ON VCP UNIT.

OPTION DISKETTE CANNOT BE UPDATED. OPTION INSTALLATION ABORTED.

The <F10> key will return to the Transfer Information Menu.

## Read System Information from VCP Unit

---

This selection will read the current configuration information from the PanelMate online system and display it for reference. The PanelMate online unit must be in the Transfer Mode. The personal computer must be connected to the serial port on the PanelMate online unit to the port on the personal computer which is configured for transferring information.

**Note** If a backup file (.BK0) is downloaded, the Read System Information screen will display the file extension as .PC0.

Press <F1> to read system configuration information or <F10> to exit.

```
TRANSFER EDITOR - READ SYSTEM INFORMATION
  F1=START      F2=          F3=          F4=          F5=
  F6=          F7=          F8=          F9=          F10=EXIT
Press F1 to read System/Configuration Information or
F10 to exit.
USER CONFIGURATION
Name:          TEST.PC0
Version:       X.XX
Date/Time:    06/12/93 15:47
Free Bytes:   15632
Used Bytes:   792
Options:      DH-485
INSTALLED DRIVER
Company/ID:    Eaton IDT, Inc.
Product:      PanelMate 1000
Version:      X.XX
Driver:       A-B Serial
Options:      DH-485
```

Figure 26-7 Read System Information Display

## Return to Main Menu

---

This selection will cause the Transfer Information Menu to appear.

# Chapter 27

## File Management

---

In this chapter, you will learn:

- How to Copy, Rename or Delete a Configuration

# The File Management Menu

---

The Configuration Software Main Menu contains a selection named Perform File Management. Choosing this selection causes the File Management Menu to appear as shown below. This menu contains four selections. The following sections will give a brief description of each selection. These utilities only operate on configuration files.

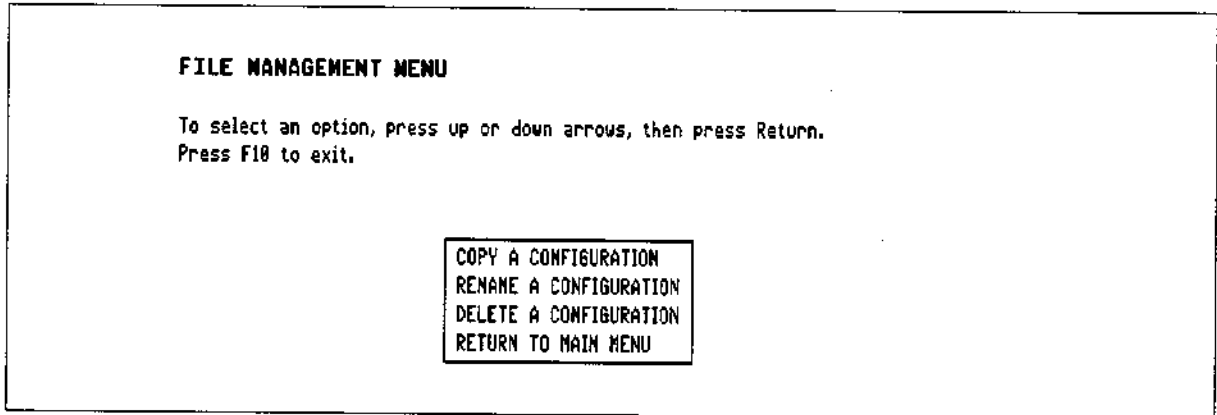


Figure 27-1 File Management Menu

## Copy a Configuration

---

This selection allows you to duplicate a configuration presently on the disk specified in the Configuration Directory in the Utility Parameters Editor and give the copy a new name.

After you have made this selection, the Utility will display a list of the configuration files presently on the disk and available for copying. It will also display two fields, one for the name of the configuration to be copied (source) and one for the name of the new copy (destination).

The source configuration name field will be open for input. You may select a file to copy by typing its name (including extension) and pressing <Return>. You may also press the <F1> key which will highlight a name in the displayed list. With this method, use the arrow keys to move the highlight to a desired name and press <Return> to select it.

After you have entered the name of the file to be copied, the destination configuration name field will be open for input. You may select a name for the new copy by typing a name (no extension) and pressing <Return>. You may also press the <F1> key which will highlight a name in the displayed list of existing files. With this method, use the arrow keys to move the highlight to a desired name and press <Return> to select it.

After the destination name has been chosen, the configuration file will be copied and stored on the hard disk. Then the following prompt will appear:

```
DO YOU WANT TO COPY ANY MORE CONFIGURATIONS?
PRESS Y TO COPY MORE CONFIGURATIONS, N TO EXIT.
```

If you answer the prompt with a "Y", the source configuration name field will be re-opened for input. You may enter it and a destination name as described above. If you answer this prompt with an "N", you will return to the File Management menu.

If you enter a destination configuration name that already exists on disk, the following message will be displayed:

```
FILE ALREADY EXISTS. DO YOU WISH TO OVERWRITE?  
PRESS Y TO OVERWRITE FILE, N TO EXIT.
```

If you answer this prompt with a "Y", the new copy of the configuration will replace the existing configuration listed as the destination. If you answer this prompt with a "N", the destination configuration name field will be re-opened for input.

## **Rename a Configuration**

---

This selection allows you to change the name of a configuration presently on the disk specified in the Configuration Directory in the Utility Parameters.

After you have made this selection, the Utility will display a list of the configuration files presently on the disk. It will also display two fields, one for the name of the configuration to be changed and one for the new configuration name.

The configuration name field will be open for input. You may select a file by typing its name (including extension) and pressing <Return>. You may also press the <F1> key which will highlight a name in the displayed list. With this method, use the arrow keys to move the highlight to a desired name and press <Return> to select it.

After you have entered the name of the file to be changed, the new configuration name field will be open for input. Select a name for the new copy by typing a name (no extension) and pressing <Return>. You may not select a name that already exists on disk.

After the new name has been chosen, the configuration file will be renamed. Then the following prompt will appear:

```
DO YOU WANT TO RENAME ANY MORE CONFIGURATIONS?  
PRESS Y TO RENAME MORE CONFIGURATIONS, N TO EXIT.
```

If you answer the prompt with a "Y", the configuration name field will be re-opened for input. You may enter it and a new name as described above. If you answer this prompt with an "N", you will return to the File Management menu.

**Note** Use this Configuration Software Package to rename files. Do not use DOS. The software not only changes the DOS filename, but it also changes the internal structure of the file so that it contains the proper name for display on the online unit. DOS copy will only change the external reference.

## **Delete a Configuration**

---

This selection allows you to erase an entire configuration from the disk specified in the Configuration Directory in the Utility Parameters Editor.

After you have made this selection, the Utility will display a list of the configuration files presently on the disk. You may select a file for deletion by typing its name (including extension) and pressing <Return>. You may also press the <F1> key which will highlight a name in the displayed list. With this method, use the arrow keys to move the highlight to a desired name and press <Return> to select it.

After you have entered the name of the file to be deleted, the following prompt will appear:

```
DO YOU REALLY WANT TO DELETE THE CONFIGURATION FILE?  
PRESS Y TO DELETE THE FILE, N TO ABORT DELETING THE FILE.
```

If you answer the prompt with a "Y", the configuration will be deleted. If you answer the prompt with an "N", no deletion will occur.

After a deletion is finished, the following prompt will appear:

```
DO YOU WANT TO DELETE ANY MORE CONFIGURATIONS?  
PRESS Y TO DELETE MORE CONFIGURATIONS, N TO EXIT.
```

If you answer the prompt with a "Y", the configuration name field will be re-opened. If you answer the prompt with an "N", you will return to the File Management menu.

## **Return to Main Menu**

---

This selection will cause the Configuration Software Main Menu to appear.

# **Chapter 28**

## **Troubleshooting the Configuration Software Package**

---

In this chapter, you will learn:

- The error messages generated by the Configuration Software

## Miscellaneous Error Messages

---

The following is a list of some of the errors which may be generated for various reasons:

WRONG KEY. TRY AGAIN.

- The user has pressed a key that is not a valid choice.

OUT OF MEMORY.

- There is not sufficient RAM in the computer to perform the task requested.

PRINTER IS OUT OF PAPER.

- The computer tried to print a file to a printer which is out of paper.

## Configuration Software Startup Error Messages

---

The following is a list of errors which may be generated while starting the Configuration Utility. These will be displayed in the Initialization Error Screen:

OVERLAY FILE(S) MISSING OR CORRUPT.

- Verify that files with an .EDT extension exist in the VCP directory and reload your software, or check the integrity of your hard drive.

INVALID BASE CONFIGURATION DIRECTORY.

- A field in the Utility Parameters Editor is no longer valid.

INVALID TEMPORARY DIRECTORY.

- A field in the Utility Parameters Editor is no longer valid.

INVALID BASE DOWNLOADABLE DRIVER DIRECTORY.

- A field in the Utility Parameters Editor is no longer valid.

INVALID INSTALL OPTION DRIVE <descriptor>.

- A field in the Utility Parameters Editor is no longer valid.

INVALID SERIAL PORT <descriptor>. APPLYING DEFAULT VALUE.

- A field in the Utility Parameters Editor no longer matches the hardware. Cycle power.

INVALID PRINTER PORT <descriptor>. APPLYING DEFAULT VALUE.

- A field in the Utility Parameters Editor no longer matches the hardware. Cycle power.

INVALID PARAMETER FOR PRINTER PORT <descriptor>. APPLYING DEFAULT VALUE.

- Specify valid value for printer.

COULD NOT CREATE TEMPORARY DIRECTORY. APPLYING DEFAULT VALUE.

- Check amount of free disk space.

INVALID BASE FIRMWARE DIRECTORY.

- A field in the Utility Parameters Editor is no longer valid.

-

There are three more error messages which may be displayed although they will not be displayed in the Initialization Error Screen. They are displayed before the Error Screen.

COULD NOT DETECT A VIDEO ADAPTER. VCP UNIT SOFTWARE ABORTED.

CANNOT EXECUTE FROM A FLOPPY DISK. VCP UNIT CONFIGURATION SOFTWARE ABORTED.

COULD NOT ALLOCATE SUFFICIENT MEMORY. VCP UNIT SOFTWARE ABORTED.

- Additional RAM memory is needed.

## **Program/File Load Error Messages**

The following is a list of errors which may be generated while loading editors or other files from disk to RAM:

COULD NOT FIND THE <filename> FILE.

- A file needed by the Utility is not on the hard disk (C:).

COULD NOT LOAD THE <filename> FILE - OPEN ERROR.

- A file needed by the Utility was found but could not be opened.

COULD NOT LOAD THE <filename> FILE - READ ERROR.

- A file needed by the Utility was found and opened but could not be read.

COULD NOT LOAD THE <filename> FILE - SECTION COMMIT.

COULD NOT LOAD THE <filename> FILE - ERROR <errornumber & errornumber>.

## Help Page Error Messages

---

The following is a list of errors which may be generated while accessing a help page:

HELP PAGE IS NOT AVAILABLE.

COULD NOT FIND HELP DATA FILE. HELP PAGE IS NOT AVAILABLE.

COULD NOT LOCATE HELP PAGE IN HELP DATA FILE. HELP PAGE IS NOT AVAILABLE.

- Reload PanelMate configuration software.

COULD NOT ALLOCATE MEMORY FOR HELP.

- Additional RAM memory is needed.

## Disk Access Error Messages

---

The following is a list of errors which may be generated while accessing the hard disk (C:), floppy disk (A: or B:), or other device:

CRITICAL ERROR.

- Check your hardware.

INVALID FILE HANDLE.

- Call Cutler-Hammer IDT for assistance.

INADEQUATE SPACE ON DEVICE.

- There is no room on device A:, B:, C:, etc.

DENIED ACCESS.

- A write has been attempted to a file with read only attributes.

TOO MANY OPEN FILES.

- Increase current file size in **config.sys** file. Call Cutler-Hammer IDT for assistance.

FILE NOT FOUND.

- Check correct file name.

UNDEFINED I/O ERROR.

- There is a DOS error.

DRIVE <descriptor> IS WRITE PROTECTED.

DRIVE <descriptor> IS NOT READY.

CRC ERROR IN <location> DURING <operation> ON DRIVE <descriptor>.

- Verify that the floppy type and drive are compatible.

SEEK ERROR DURING <operation> ON DRIVE <descriptor>.

- Verify that the floppy type and drive are compatible.

UNKNOWN MEDIA TYPE ON DRIVE <descriptor>.

- Verify that the floppy type and drive are compatible.

SECTOR NOT FOUND DURING <operation> ON DRIVE <descriptor>.

- Verify that the floppy type and drive are compatible.

WRITE FAULT ERROR IN <location> ON DRIVE <descriptor>.

- Verify that the floppy type and drive are compatible.

READ FAULT ERROR IN <location> ON DRIVE <descriptor>.

- Verify that the floppy type and drive are compatible.

GENERAL <operation> FAILURE ON DRIVE <descriptor>.

- Verify that the floppy type and drive are compatible.

# File Name Error Messages

---

The following is a list of errors which may be generated when you specify a file name:

FILE NAME CONTAINS INVALID CHARACTERS. YOU MUST REENTER THE FILE NAME.

INVALID FILE NAME. YOU MUST REENTER THE FILE NAME.

INVALID FILE PATH. YOU MUST REENTER THE FILE NAME.

FILE NAME MUST INCLUDE AN EXTENSION. YOU MUST REENTER THE FILE NAME.

FILE COULD NOT BE FOUND. YOU MUST SELECT ANOTHER FILE NAME.

FILE ALREADY EXISTS. YOU MUST SELECT ANOTHER FILE NAME.

FILE NAME MUST BE ENTERED. YOU MUST REENTER FILE NAME.

- Enter filename to continue.

FILE NAME IS A SUBDIRECTORY. YOU MUST SELECT ANOTHER FILE NAME.

FILE NAME IS NOT A SUBDIRECTORY. YOU MUST SELECT ANOTHER FILE NAME.

FILE IS NOT A VALID VCP UNIT CONFIGURATION. YOU MUST REENTER THE FILE NAME.

INVALID CONFIGURATION CHECKSUM.

- File is corrupt. Call Cutler-Hammer IDT for assistance.

FILE NAME MUST NOT INCLUDE AN EXTENSION. YOU MUST REENTER THE FILE NAME.

FILES DRIVE LENGTH IS INVALID. YOU MUST REENTER THE FILE NAME.

- Verify that the drive name has one character.

FILE NAME LENGTH IS INVALID. YOU MUST REENTER THE FILE NAME.

FILE NAME EXTENSION LENGTH IS INVALID. YOU MUST REENTER THE FILE NAME.

- File name extension must not exceed three characters in length.

FILES PATH IS INVALID. YOU MUST REENTER THE FILE NAME.

# Chapter 29

## Allen-Bradley PLCs

---

The PanelMate Series 1000 can be used with any of the programmable controllers in the Allen-Bradley PLC, PLC-2, PLC-3, PLC-5, and SLC 500 families. Communication to a PLC can be accomplished in a number of different ways. These include: direct connection to a single PLC; connection to Data Highway or Data Highway Plus via an intermediate serial communication module; direct connection to Data Highway, Data Highway Plus, or Remote I/O using the Accelerat/On interface; direct connection to Data Highway 485 via an intermediate serial communication module. Instructions for use of Accelerat/On begin in Chapter 30.

# Memory

See your PLC manual for information on memory ranges.

## Possible Configurations

Examples of possible connections are described and shown in the following pages.

### Serial Communication to One PLC

If the PanelMate unit is to communicate to a single PLC, a direct connection is most efficient. This allows the connection to be made with a single Allen-Bradley module (1747-AIC, 1771-KG, 1775-KA or 1770-KF2B).

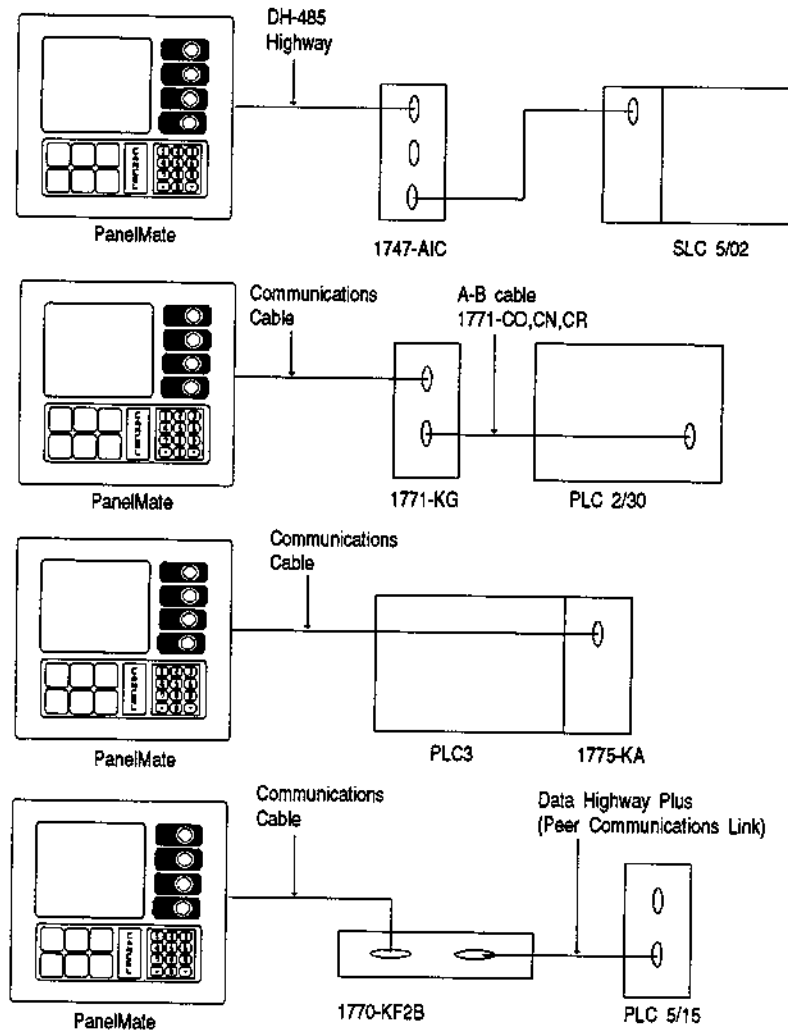


Figure 29-1 Connection to a Single PLC

## Data Highway Connections Using Serial Communication Modules

Multiple devices may be interconnected via Data Highway. Each device needs its own module to communicate on the highway. Switch settings, described later in this section, determine each device's station address.

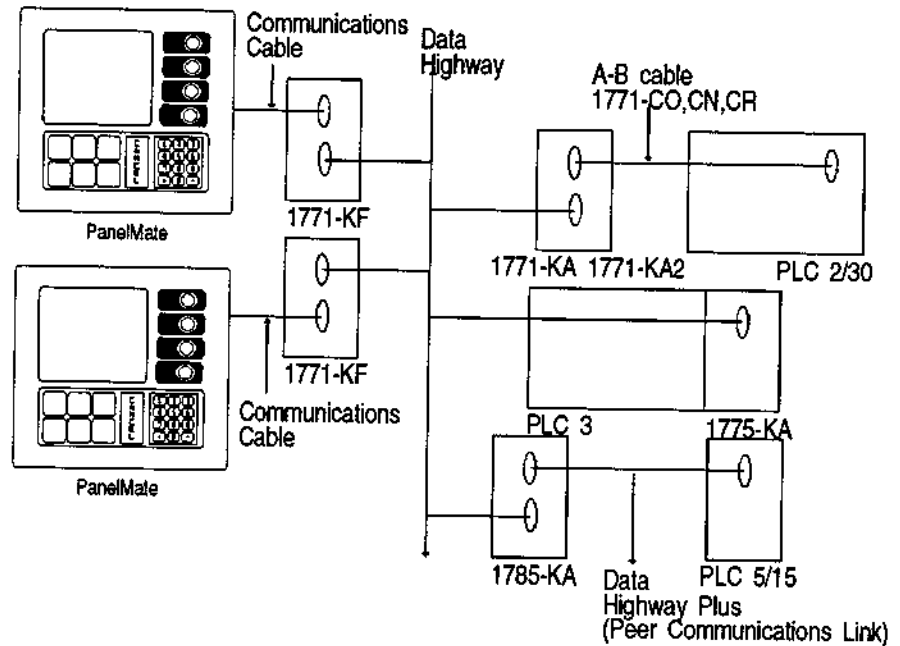


Figure 29-2 Multiple Data Highway Connections

## Multiple Data Highways Using Serial Communication

If a substantial volume of Data Highway communication is necessary to other devices in addition to the PanelMate unit, it may be desirable to establish a dedicated Data Highway or direct connections for the PanelMate unit to avoid extended response times due to highway traffic. Allen-Bradley's 1771-KA2 and 1771-KG modules allow multiple routes into a single PLC-2 processor. The PLC-3 accepts multiple 1775-KA modules.

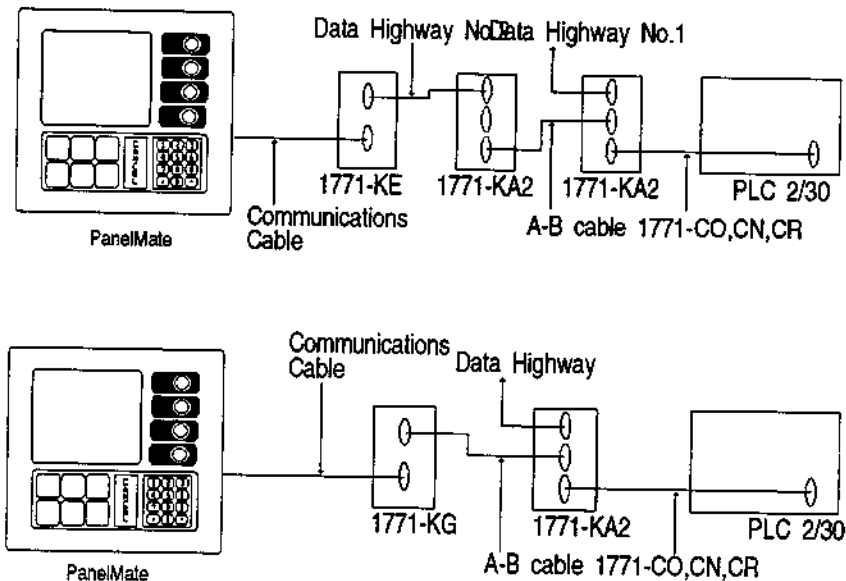


Figure 29-3 Multiple Data Highway Connections

## Direct Connection to Data Highway 485

The PanelMate unit can communicate to the SLC 500, 5/01, and 5/02 PLCs. The PanelMate unit reads the I/O configurations when going online and must be in the online mode or turned on after all of the other nodes on the network. If you make additions or deletions to the I/O in your PLC, you must power the PanelMate unit down and back up to update the I/O configurations. Due to an Allen-Bradley PLC limitation, the PanelMate unit can only write to an output file if the SLC has a 5/02 processor and the output file was saved allowing this option. If you are using a SLC 500 or 5/01 PLC and attempt to write to an output file, an error message will be displayed. See the Communication Errors section in Chapter 6 for more information.

A 1747-AIC module must be used to communicate to all SLC PLCs. When communicating on a Data Highway 485, the PanelMate unit must be an end node, therefore, only two PanelMate units can be connected on the DH-485 as shown in the following figures.

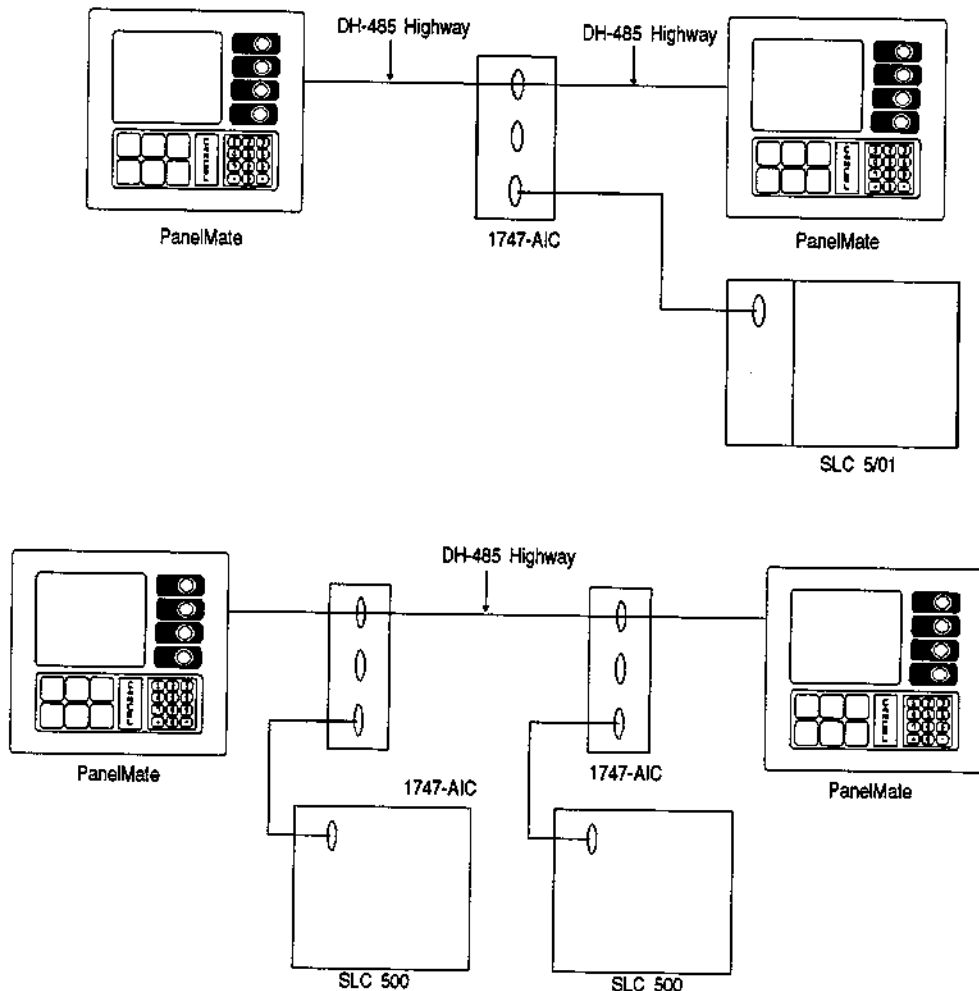


Figure 29-4 Multiple Data Highway 485 Connections

**Note** Allen-Bradley requires that no more than two initiators (i.e., two PanelMate units or one PanelMate unit and a programmer) access the SLC 500 or SLC 5/01 models. The Allen-Bradley SLC 5/02 does not have the two initiator limitation.

## PLC-3 Data Access

---

The PanelMate unit can communicate with Allen-Bradley programmable controllers via the Data Highway or direct connection using PLC-2 protocols. The PLC-3 and 1775-KA Communications Adaptor Module can recognize these protocols and allow the PanelMate unit to access data table memory as if that memory were resident in a PLC-2 series processor.

In this manner, the PanelMate unit communicates through a file in the Input Image Section of the PLC-3 Data Table, where file number (10-100) corresponds to the station address of PanelMate unit. This is set as the Network ID# in the Port Parameter Table in the PLC Name and Port Editor. Status from real-world input modules are stored in Input Image File 0 and are not affected.

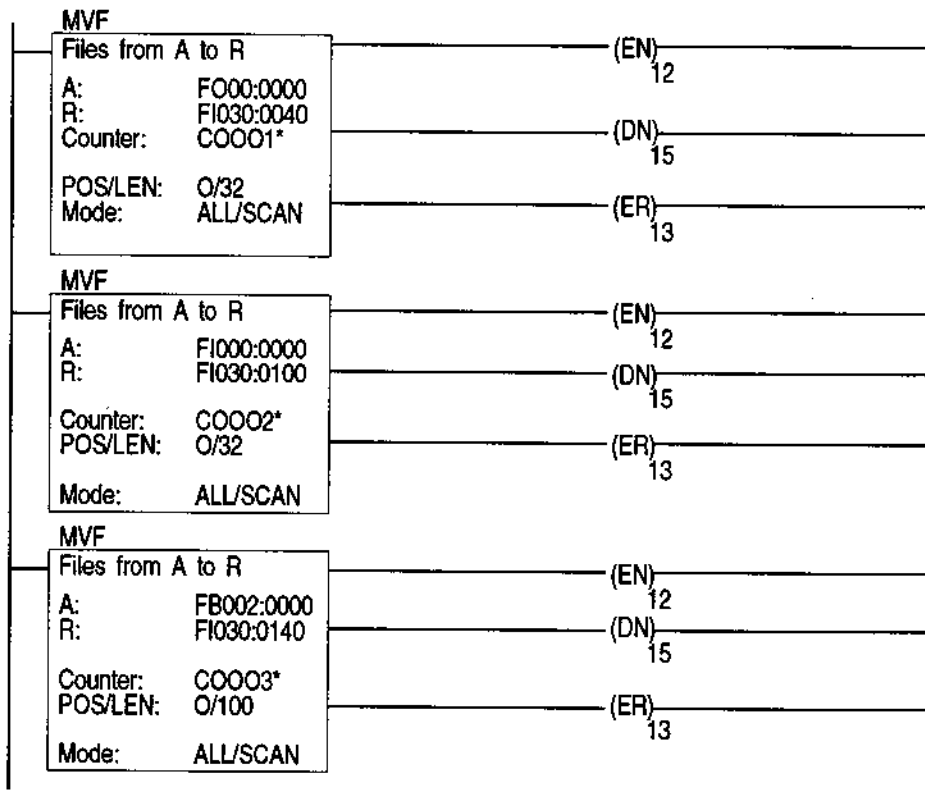
You should map any I/O and numeric data which is to be used by the PanelMate unit from other areas of the data table, into the assigned Input Image File. This can be easily accomplished in a few rungs of ladder logic, using Move File (MVF) instructions. This creates a compact data sub-table that the PanelMate unit can access with a minimum number of reads, resulting in optimum communications response.

The following is an example of this technique. Assume that you want to use the following data in the PanelMate unit:

	<u>Points Used</u>	<u>PLC-3 Data Table Addresses</u>
512 Outputs	O0000/00-O0037/17	FO0:0-FO0:31
512 Inputs	I0000/00-I0037/17	FI0:0-FI0:31
100 Binary Values	first 100 words of Binary File 2	FB2:0-FB2:99

Assume that the Network ID# of the PanelMate unit is octal 30. Thus, the "window" we will be using will be Input Image File 30 (decimal). (Note that if PanelMate's ID is 0, Input Image File 8 is automatically selected.) You should ensure that this file has already been created (see PLC-3 Programming Manual Publication 1775-801).

The following three rungs would be included in the PLC-3 ladder diagram to map the three desired memory areas into file I030.



\* You can pick any three unused counters.

### Controlling Data

If data and I/O points are to be controlled by the operator via pushbutton or numeric entries, extra rungs can be added to move data from File I030 into appropriate locations. The words used in I030 for data sent by the operator must be outside the block areas written over by the above MVF rungs. In the above example, we have left words 0000 through 0037 available for writes.

Good engineering practice dictates that controlled statuses in the chosen Input Image File will not be written back into FI0.

### Configuration Entries

With this technique, entries made for PLC-3 addresses in the Template Editors are then identical to those made for PLC-2 processors. Refer to Chapters 5, 6, 7, and 8 of this manual for specifics on each template type.

Continuing with the previous example, the following PLC-2 type addresses would then be used to reference the PLC-3 data.

<u>PLC-3 Addresses</u>	<u>PLC-2 Address Used in a PanelMate Unit</u>
FO000000 to O003117	[40 00] to [77 17]
FI000000 to I003717	[100 00] to [137 17]
FB002:0000 to FB002:0099	[140] to [303]

\* Assumes default PLC

## PLC-5 Data Access

The diagram which follows illustrates that the 1785-KA module provides an interface between Data Highway Plus and Data Highway. Note again that the 1785-KA station address must be different from the other device addresses. Addresses and ID numbers shown in the diagram are samples only.

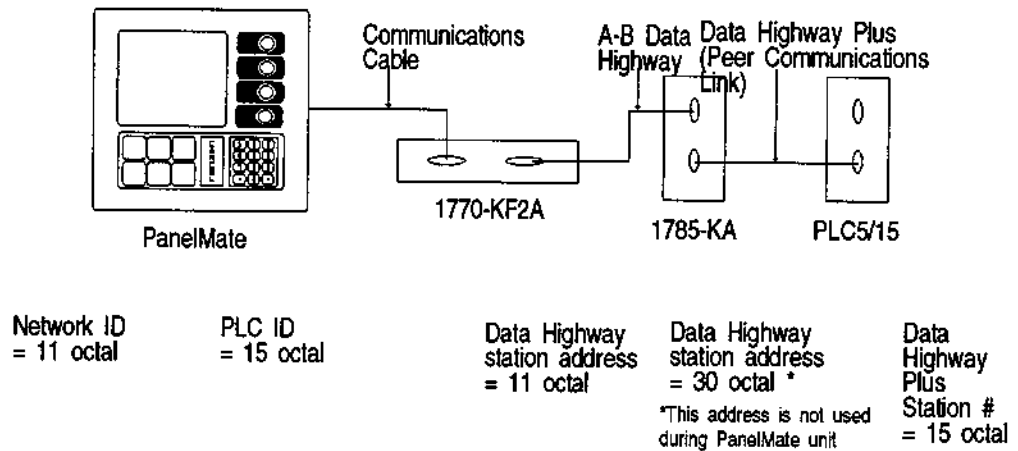


Figure 29-5 Connection to a PLC-5

The 1770-KF2B module can provide access for the PanelMate unit to use the Data Highway Plus with the PLC-5, as shown in the diagram which follows:

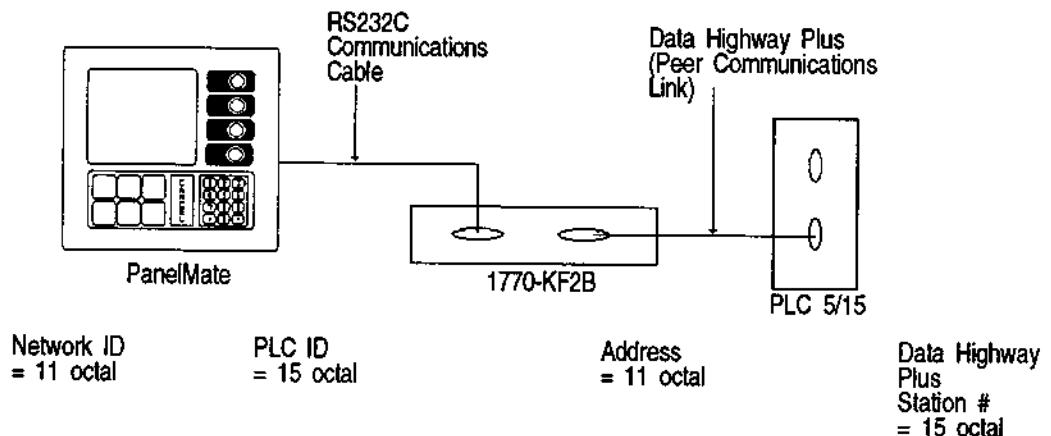


Figure 29-6 Connection to a PLC-5

The PanelMate unit can communicate with Allen-Bradley PLC-5's via the Data Highway Plus or direct connection using PLC-5 protocols. The PLC-5 can recognize these protocols via Data Highway Plus through interpretation by the 1770-KF2 unit B, the 1785-KE, or the 1785-KA modules and allow the PanelMate unit to access multiple files in the PLC-5.

### **Accessing Data**

The PanelMate unit can access the following file types through the PLC-5 Command Set:

- Bit
- Integer
- Control
- Timer
- BCD
- Counter
- Input
- Output
- Status

See the Allen-Bradley PLC-5 Word and Bit References section for more information.

### **Controlling Data**

The operator controls the data I/O points in the PanelMate unit via pushbuttons or numeric entries. The PanelMate unit will not allow inputs to be written. See PLC-5 Word and Bit References for more information.

### **Configuration Entries**

When configuring the PanelMate unit for a PLC-5, select the PLC driver with the appropriate model from the onscreen choices presented in the PLC Name and Port Parameters Editor. For example, if a PLC-5/15 is used then the configuration should read "PLC 5/15".

## SLC 500 Data Access

The SLC 500 Series supports a DH-485 link which uses a token-passing protocol with rotating mastership. The nodes are connected in a daisy chain fashion on the network with a maximum length of 4000 feet.

The DH-485 data link supports two types of devices: initiators (masters) and responders (slaves). All initiators on the link have a chance to initiate message transfers. The PanelMate unit will be an initiator on the network. If more than one PanelMate unit is on a network, a token passing algorithm is used to determine which initiator has the right to transmit.

The node address of a master can be any number from 0 to 31 and the address range for all slaves is 1 to 31. Therefore, the maximum number of nodes allowed on the link is 32. Typically, the PLC programmer defaults to node 0. The best network performance occurs when node addresses start at 1 and are assigned in sequential order. This minimizes the time to initialize the link.

Most DH-485 devices have a parameter which sets the maximum node address. The maximum node address should be set as low as possible. This minimizes the amount of time used in soliciting data when initializing the link and when finding new data when token passes do not receive a response. This field can be configured in the PLC Name and Port Table Editor. When your cursor is on a Use field selected for DH-485, pressing <F2> will recall the Allen-Bradley Data Highway 485 Maximum Node Address Editor. Open the field by pressing <Return>, then use your arrow keys to select the maximum node address.

The 1747-AIC communication module must be used with the SLC 500 PLCs.

## Allen-Bradley Modules

A description of Allen-Bradley modules is given below. Consult the Allen-Bradley Data Highway Module Publications 1771-801, 807, 811, or 822 for more details.

Allen-Bradley modules for serial connections:

PLC Family	PLC-2	All	All	All	PLC-3	PLC-5	PLC-5
Module	1771-KG	1771-KE	1771-KF	1770-KF2A	1775-KA	1770-KF2B	1785-KE
Mounting	Rack	Rack	Panel	Desktop	Chassis	Desktop	Rack
Cable Connector	DB-15P	DA-15P	DA-15P	DB-25S	DB-25S	DB-25S	DA-15P
Connection	Direct	Data Hwy	Data Hwy	Data Hwy	Direct/ Data Hwy	PCL/ Data Hwy	PCL
Port Label	RS232C	RS232C	RS232C	Computer	Modem/ Data Hwy	Computer	Computer (RS232)

Table 29-1 Modules & Connectors for Allen-Bradley PLCs

Allen-Bradley modules for PLC to Data Highway connections:

PLC Family	PLC	PLC-2	PLC-3	PLC-5
Module #	1774-KA	1771-KA 1771-KA2	1775-KA	1785-KA

**Table 29-2 Modules for Data Highway Connection**

Allen-Bradley modules for PLC to Data Highway Plus connections:

PLC Family	PLC	PLC-2	PLC-3	PLC-5
Module #	-	1785-KA3	1775-S5	Built-in

**Table 29-3 Modules for Data Highway Plus Connection**

Allen-Bradley modules for PLC to Data Highway 485 connections:

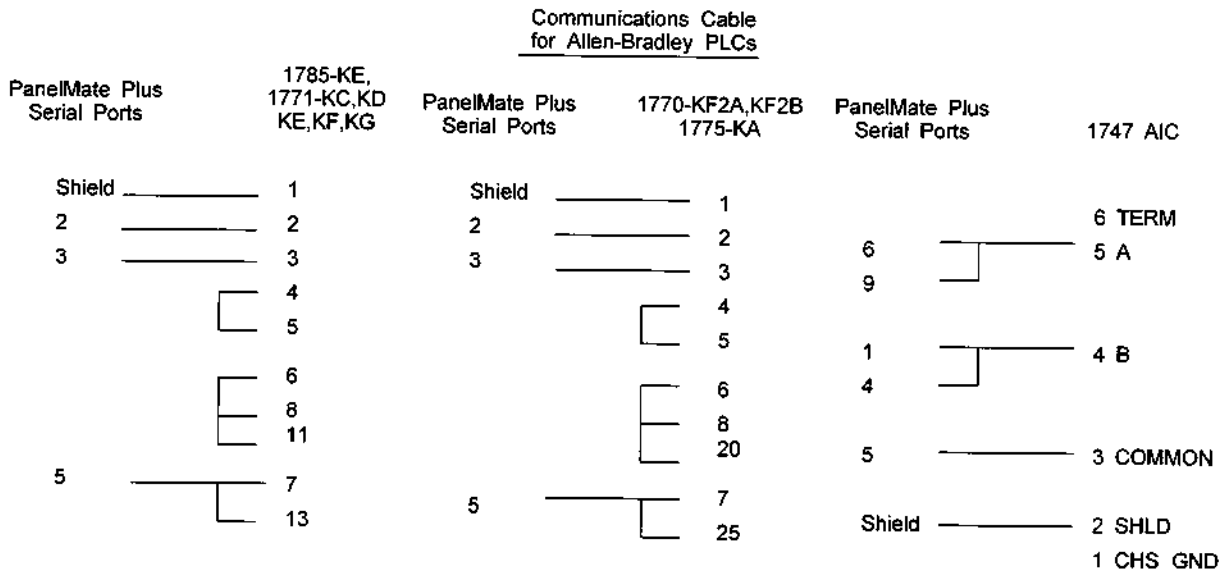
PLC Family	SLC 500	SLC 5/01	SLC 5/02
Module #	1747-AIC	1747-AIC	1747-AIC
Mounting	Panel	Panel	Panel
Cable Connector	6-position terminal block	6-position terminal block	6-position terminal block
Connection	DH-485	DH-485	DH-485
Port Label	DH485 INTFC	DH485 INTFC	DH485 INTFC

**Table 29-4 Modules for Data Highway 485 Connection**

# Cabling

The communication between the PanelMate unit serial ports and most Allen-Bradley modules is RS232C, and so has a recommended maximum cable length of 50 feet. You should construct a communication cable of the desired length for each connection to be made. Note that the cable configuration is identical on the PanelMate unit side for the various communication modules, with different connectors and pin outs on the Allen-Bradley end. Refer to the figure below for the connector required for each module. All PanelMate unit ports are female 9-pin (DB-9S), and so the connectors on the cables must be male 9-pin (DB-9P).

Cable shields should be grounded at one end only.



**Figure 29-7 Cabling Diagrams**

# Communications Parameters

---

Each Allen-Bradley module has parameters which must be set in order to establish communications with the PanelMate unit. This is accomplished either through DIP switch settings on the individual module or programming selections using an Allen-Bradley programming terminal or programming software.

Standard communications parameters for communicating with a PLC-2, PLC-3, or PLC-5 are:

- 8 data bits
- 1 stop bit
- no parity
- 9600 baud rate

Standard communications parameters for communicating with a SLC 500 PLC are:

- 8 data bits
- 1 stop bit
- even parity
- 19200 baud rate

Note that the baud rate parameter is selectable, but Cutler-Hammer IDT recommends using the setting 19200 for SLC 500 PLCs if it is available.

The following is a summary of the information available at the time of this manual's printing, describing the necessary settings for each of the modules. Be sure to check with Allen-Bradley for any possible updates or changes if you encounter any difficulty in communicating to the PanelMate unit.

## Modules for PLC Data Highway Connection

1771-KA, 1771-KA2

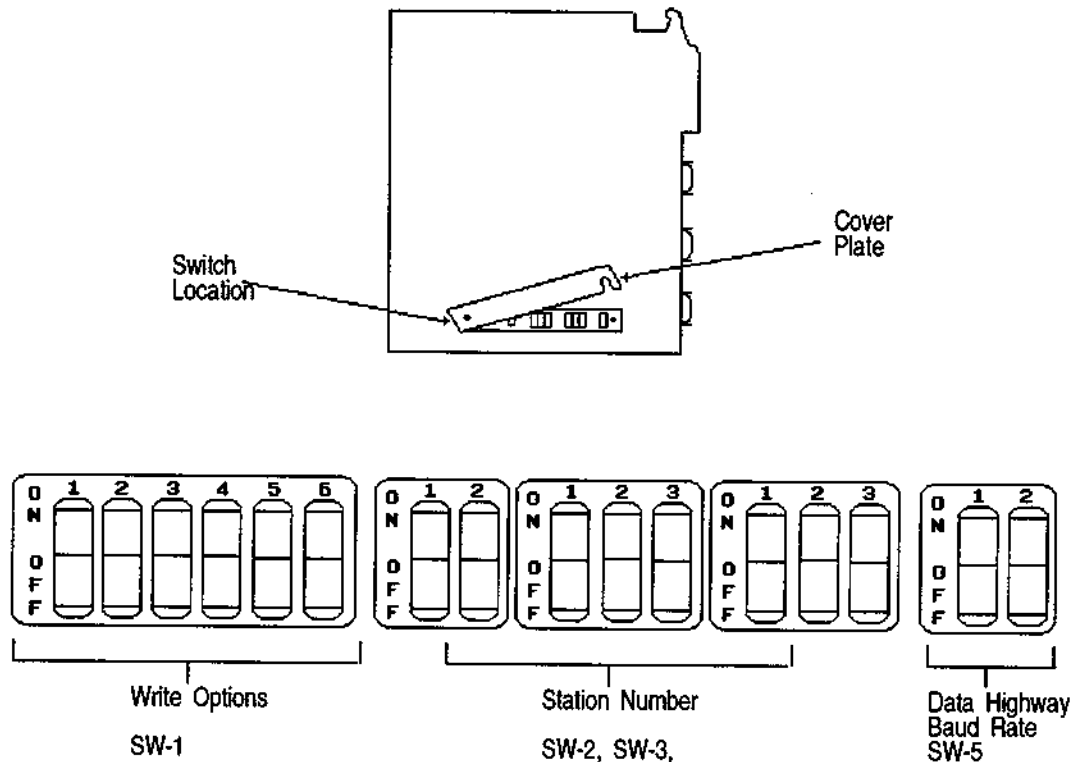


Figure 29-9 1771-KA and 1771-KA2 Module

SW-1 Set switches 2 and 6 ON, and others OFF.  
 For 1771-KA2:  
 Set switches 2, 5 and 6 ON, and 1, 3 and 4 OFF.

**Note** Switch 6 on SW-1 is OFF when a 1771-KA module is connected to a PLC-2 (1772-LR).  
 Switch 6 on SW-1 is OFF when a 1771-KA2 module is connected to a PLC-2 (1772-LR), a 1771-KG series B or another 1771-KA2 module.

SW-2,3,4 These switches should be set as the octal equivalent of the decimal PLC ID# you have established for this unit in the PLC Name and Port Editor.

SW-5 Set switches 1 and 2 ON (57.6K Baud).

## 1775-KA

The 1775-KA settings are programmed using the Allen-Bradley programming terminal (T50).

Station Address	A number between 10 and 377 (octal) that is the octal equivalent of the decimal PLC ID# you have established for the PLC in the PanelMate unit's PLC Name and Port Editor.
Module Status	Enabled

Be sure to match the baud rate, parity, data bits and stop bits with the entries made in the PLC Name and Port Editor.

## 1785-KA

The 1785-KA module acts as an interface between Data Highway Plus and Data Highway. The station number, set by DIP switches on the module, is its Data Highway address, which must be different from the PanelMate unit Data Highway address and the PLC-5's Data Highway Plus station number.

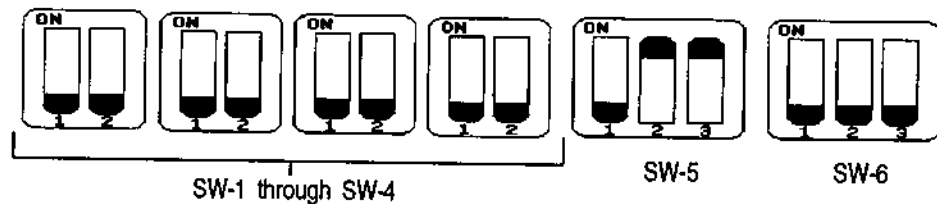


Figure 29-10 1785-KA Module DIP Switches

SW-1 through SW-4	These are spare switches which should be set OFF as shown.
SW-5, 6	These switches represent the two-digit Data Highway address. The setting illustrated in Figure 29-9 is for an address of 30 octal. (This is not the PLC ID#.)

# Modules for the PanelMate Data Highway Communication

1771-KE, 1771-KF

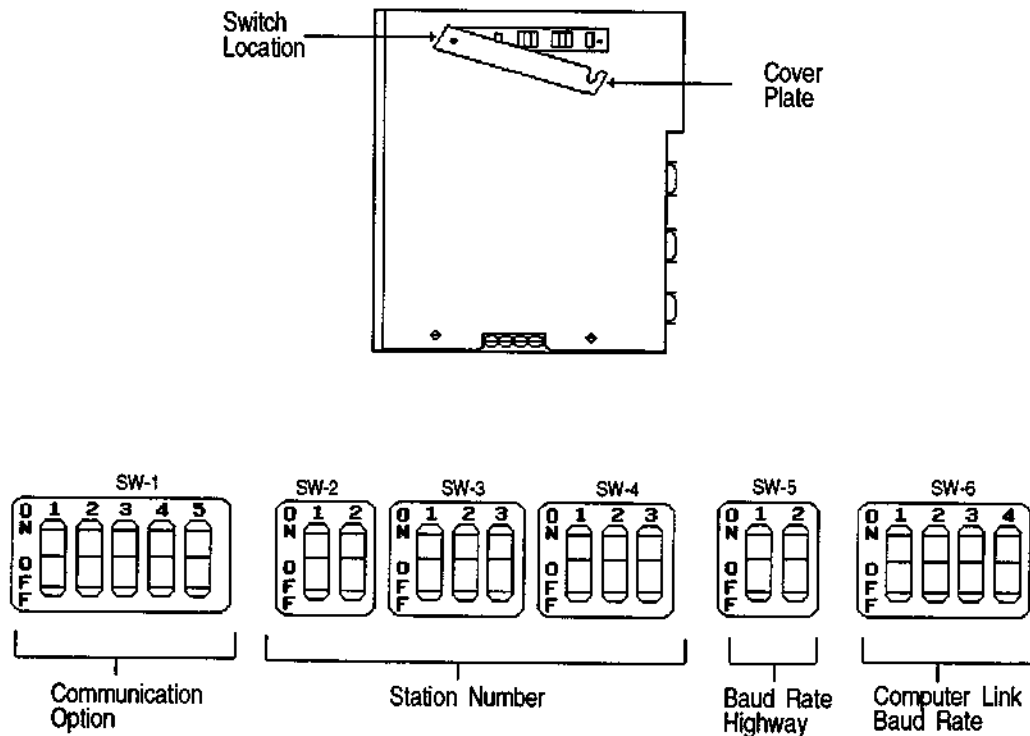


Figure 29-11 1771-KE and 1771-KF Module

Switch settings for Revision H of 1771-KE, 1771-KF

- SW-1 Switches 1, 2, 3, 4 and 5 OFF.
- SW-2,3,4 These switches should be set as the Network ID# you have established in the PanelMate PLC Name and Port Editor.
- SW-5 Switches 1 and 2 ON (57.6K Baud)
- SW-6 To use the default communications settings: switches 2, 3 and 4 ON, switch 1 OFF. This will produce the following settings: 9600 baud, module diagnostics are on. If switch 4 is OFF, the module will not execute diagnostics. To use other settings, be sure that the PanelMate unit and PLC settings match.

For Revision levels prior to H, same as above except:

- SW-1 Switches 1, 2, 3 and 4 OFF. Switch 5 ON.
- SW-6 Switches 2 and 3 ON. Switches 1 and 4 OFF.

## 1771-KC, 1771-KD

SW-1	Communication options switches. Switch 2 and 5 must be OFF; others are not used.
SW-2, 3, 4	Station number switches. These should be set for the octal equivalent of the decimal Network ID#.
SW-5	Data Highway baud rate switches 1 and 2 must be ON (57.6K Baud).
SW-6	Computer link baud rate switches: 1 OFF 2 ON 3 ON 4 ON (9600 Baud)

## 1770-KF2 Series A, 1770-KF2 Series B

The 1770-KF2 Series A and Series B are desktop modules which can act as interfaces for the PanelMate unit to the Data Highway. The Series B performs the same function as the Series A, and can alternately act as a direct interface to the PLC-5 through Data Highway Plus.

The layout of the DIP switches for setting communications parameters is identical for the two modules, except that SW-7 is not used on the Series A, but is functional on the Series B.

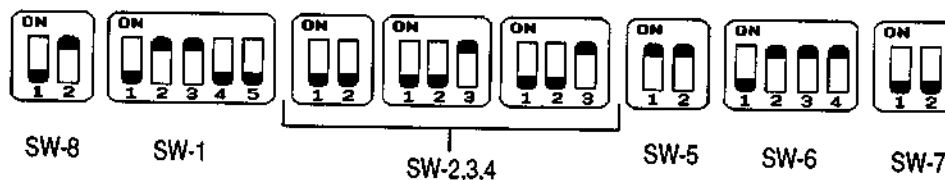


Figure 29-12 1770-KF2A, 1770-KF2B Module DIP Switches

### Switch Settings

SW-8	Note that this switch is to the left of the other switches in the previous diagram. For RS232C communication, set switch 1 OFF and switch 2 ON (as shown in the diagram). For RS422 communication, set switch 1 ON and switch 2 OFF.
SW-1	Switches 1, 4 and 5 OFF. Switches 2 and 3 ON.
SW-2, 3, 4	These switches represent the three-digit octal station number. They should be set as the Network ID# you have established in the PLC Name and Port Editor. The setting illustrated in the previous diagram is for an address of 11 octal (9 decimal).
SW-5	Set both switches to ON, for a Data Highway rate of 57.6K baud.
SW-6	For a communication rate of 9600 baud, set switch 1 OFF and switches 2 and 3 ON (as shown in Figure 14-13). Set switch 4 ON.
SW-7	For Data Highway operation, set both switches 1 and 2 OFF.

## Modules for Direct Connection

### 1771-KG

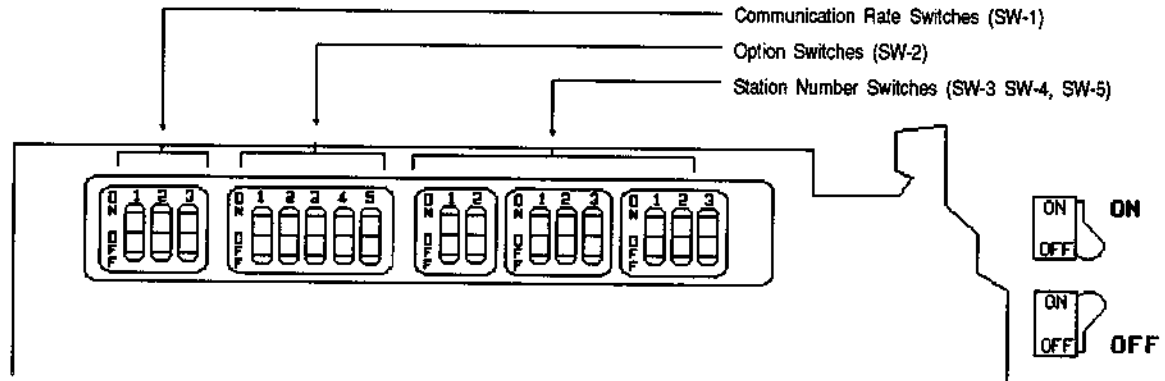


Figure 29-13 1771-KG Module

Switches are located behind a cover plate at the top of the module.

SW-1	For the following communication parameters, 8 data bits, 1 stop bit, no parity, and 9600 baud, set switch 1 OFF and switches 2 and 3 ON.
SW-2	Set switches 1, 2 and 5 OFF, and switch 3 ON. Switch 4 should be set ON if KG is the first module, OFF if KG is the second module regardless of the number of KG modules.
SW-3,4,5	These switches determine the octal PLC ID number and are set as on the 1771-KA.

### 1775-KA

The 1775-KA settings are programmed using the Allen-Bradley Industrialized Programming Terminal (T50) or programming software.

Data Highway Baud Rate	57.6K Baud
Station Address	A number between 10 and 377 (octal) that coincides with the octal equivalent of the decimal PLC ID# you have established for the PanelMate unit.
Port Status	Enabled
Baud and Parity	Set to match parameters configured in the PLC Name and Port Editor. Default: 9600 baud, 8 data bits, no parity.
Module Timeout	Typically 0.5 seconds
Unpolled Mode	(modem port)

Accepts Writes	Enabled - Writes from the PanelMate unit are accepted even if PLC keylock is in "Memory Protection ON" position. Disabled - Writes from the PanelMate unit are only accepted when PLC keylock is in "Memory Protect OFF" position.
Send Embedded Responses	Enabled

## Modules for PanelMate to Data Highway Plus Connection

### 1770-KF2 Series B

The 1770-KF2 Series B module can act as a direct interface to the PLC-5 through Data Highway Plus.

The layout of the DIP switches for setting communications parameters is shown below.

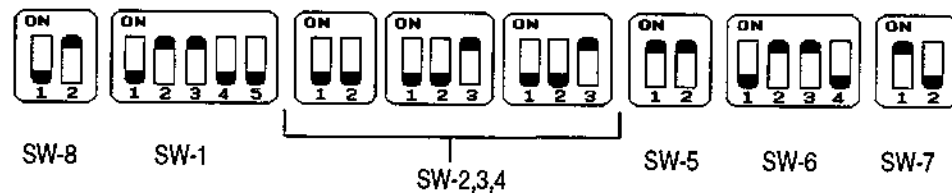


Figure 29-14 1770-KF2B Module DIP Switches

### Switch Settings

SW-8	Note that this switch is to the left of the other switches in the previous diagram. For RS232C communication, set switch 1 OFF and switch 2 ON (as shown in the diagram). For RS422 communication, set switch 1 ON and switch 2 OFF.
SW-1	Switches 1, 4 and 5 OFF. Switches 2 and 3 ON. These switches control the special features of the KF2 module's asynchronous port.
SW-2, 3, 4	These switches represent the three-digit octal station number. They should be set the same as the Network ID# you have established for the PanelMate unit. The setting illustrated in the previous diagram is for an address of 11 octal (9 decimal).
SW-5	Set both switches to ON, for a Data Highway rate of 57.6K baud.
SW-6	For a communication rate of 9600 baud, set switch 1 OFF and switches 2 and 3 ON (as shown in Figure 29-14). Set switch 4 OFF.
SW-7	For Data Highway Plus operation (not functional with KF2A), set switch 1 ON and switch 2 OFF.

### 1785-KE Series A

- SW-1 Switches 1, 2, 3, 4 and 5 OFF.
- SW-2 Both switches OFF.
- SW-3, 4 These switches represent the two-digit octal station number. (PanelMate Network ID#)
- SW-5 Set both switches ON for a Data Highway Plus rate of 57.6K baud.
- SW-6 For a communication rate of 9600 baud, set switch 1 and 4 OFF and set switches 2 and 3 ON.

### 1785-KE Series B

- SW-1 Switches 1, 2, 3, 4, 5 and 6 OFF.
- SW-2 These switches represent the three-digit octal station number. Switches 1 and 2 represent octal digit 0 and are not used. Both switch 1 and 2 should be set to ON. Switches 3, 4 and 5 represent the first octal digit, the most significant bit of the Data Highway Plus node address. Switches 6, 7 and 8 represent the second octal digit, the least significant bit of the Data Highway Plus node address. (PanelMate Network ID#)
- SW-3 For a communication rate of 9600 baud with a Data Highway Plus rate of 57.6K baud, set switches 1, 2, 4 and 5 ON and switch 3 OFF.
- SW-4 Both switches OFF.

# Modules to Connect PanelMate to Data Highway 485

## 1747-AIC

The 1747-AIC module is used to connect SLC 500 PLCs to the Data Highway 485 network. The module provides a six position removable screw terminal block for connection to the communications cable.

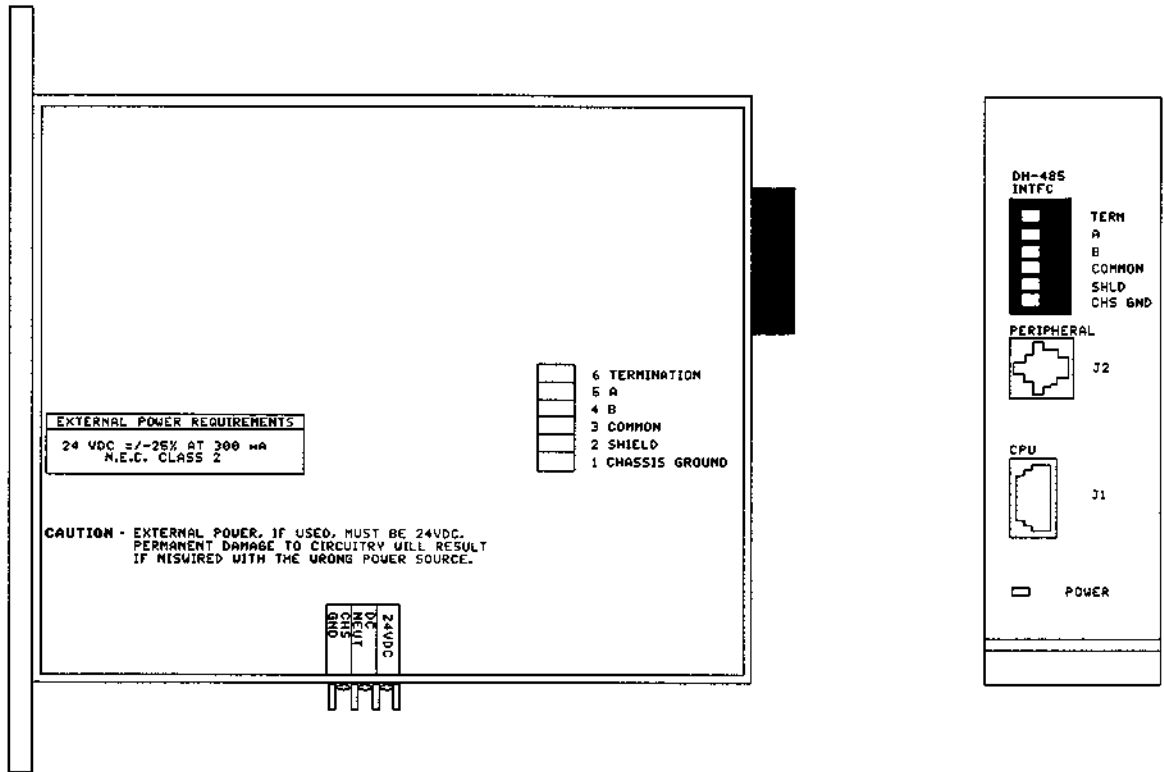


Figure 29-15 1747-AIC Module

## Allen-Bradley Word and Bit References

---

The following section describes the use of Allen-Bradley word and bit references in your configuration. The general word referencing method is:

[plcname,word#format]

The "plcname" is the name of the designated PLC as listed in the PLC Name and Port Table. The "word" is the reference number (address) of the word or register to be read or written. The "#format" is a code which specifies the format of the data being read or written. The "plcname" and "#format" are optional.

The general bit referencing method is:

[plcname,bit]

The "plcname" is the designated PLC as listed in the PLC Name and Port Table. The "bit" is the reference number (address) of the bit, coil, or input to be written or read.

See chapter 10 for a more detailed explanation of word and bit references, including format descriptions.

### PLC-2 Word and Bit References

---

Allen-Bradley PLC-2 uses octal word addresses. You should select "PLC-2 o" at the model field in the PLC Name and Port Editor to specify octal addressing. The PanelMate unit default format is BCD3.

The following is the format for a word reference:

[ww]

ww = PLC reference number of the word.

The following is the format for a bit reference:

[ww bb]

ww = PLC reference number of the word.

bb = PLC reference number of the bit.

Note that there must be a space between the word and bit.

The PanelMate unit can read all words between 10 and 77 (except word 27) and can read all words from 110 to the upper limit of your specific PLC-2.

The PanelMate unit can read all bits in the above words.

The PanelMate unit can reference more than one PLC word with a single read. The Allen-Bradley PLC-2 can read a maximum of sixty words per read. The maximum number of unused PLC words per PanelMate read is fifteen. (Once fifteen unused PLC words are encountered, the PanelMate unit will generate another read.)

The PanelMate unit can write to all words, and bits in all words, between 10 and 77 (except word 27) and can write to all words, and bits in all words, from 120 to the upper limit of your specific PLC-2 UNLESS a word is configured as an input. The PanelMate unit can write to all bits in the above words.

## PLC-3 Word and Bit References

---

Addressing for words and bits used in the PanelMate unit expressions is octal for the PLC-2 and PLC-3 families. You should select "PLC-2 o" at the model field in the PLC Name and Port Editor to specify octal addressing. The PanelMate unit default format is BCD3.

By adhering to the following procedure, you can use the PLC-2 driver for communications with a PLC-3:

1. Use an Input Image File, other than file 0, for all words and bits that will be accessed by the PanelMate unit.
2. The PanelMate unit will read and write to the Input Image File that corresponds to the Network ID# assigned to the serial port communicating with the PLC-3. For example, assume that Serial Port 2 will be used for communications to a PLC-3. By assigning Network ID# 30 to Serial Port 2 of the PanelMate unit, the online unit will access Input Image File 30 in the PLC-3.
3. Use PLC logic to move the necessary data to the assigned Input Image File.
4. Be sure that data formats are consistent. You can use format assignments in the PanelMate unit expression references or data moves in the PLC to ensure that the data formats are identical in both the PanelMate unit and the PLC.

The PanelMate unit can reference more than one PLC word with a single read. The Allen-Bradley PLC-3 can read a maximum of sixty words per read. The maximum number of unused PLC words per read is fifteen. Once fifteen unused PLC words are encountered, the PanelMate unit will generate another read.

## PLC-5 Word and Bit References

---

The Allen-Bradley PLC-5 uses decimal word addresses. The PanelMate unit default format is S16. The following word and bit addressing descriptions apply to the PLC-5 Command Set.

### General Format

[xf:e.s/b]

**Note** /b is an optional field

where

x = File Type

B - Bit	(signed 16)
N - Integer	(signed 16)
R - Control	(signed 16)
T - Timer	(signed 16)
D - BCD	(BCD 4)
C - Counter	(signed 16)

**Note** In Counter, Timer, and Control files word 0 is read only, and words 1 and 2 are read/write.

f = File Number

- 0 - 2 Reserved
- 3 - Bit
- 4 - Timer
- 5 - Counter
- 6 - Control
- 7 - Integer
- 8 - (invalid) Floating Point
- 9-999 - Additional file storage

**Note** The above list of file types are default for Allen-Bradley. They can be changed by the user.

: = Element delimiter

e = Element number

0 - 999 - (in decimal)

. = Subelement delimiter

s = Subelement mnemonic (used with Counter (C), Timer (T), and Control (R) files).

Timer (T):

PRE - Preset Value (word 1)

ACC - Accumulated Value (word 2)

Counter (C):

PRE - Preset Value (word 1)

ACC - Accumulated Value (word 2)

Control (R):

LEN - Length (word 1)

POS - Position (word 2)

/ = Bit delimiter

b = Bit number (not used in word references)

0-15999 - Decimal for Bit (B) type files when element number is not specified (optional)

0-15 - Decimal for all other file types, including Bit (B) type files which specify the element number

Certain file types allow mnemonics to be used instead of the actual bit number. The mnemonic should be placed after the "." and the "/" is not used in this case. The following is a list of mnemonics that can be used.

<u>Bit</u>	<u>Timer (T)</u>
15	EN enable
14	TT timing
13	DN done
0-12	INVALID
<u>Bit</u>	<u>Counter (C)</u>
15	CU up enable
14	CD down enable
13	DN done
12	OV overflow
11	UN underflow
0-10	INVALID
<u>Bit</u>	<u>Control (R)</u>
15	EN enable
14	EU unload enable
13	DN done
12	EM empty
11	ER error
10	UL unload
9	IN inhibit
8	FD found
0-7	INVALID

## I/O Format

When using the PanelMate unit to access I/O file types in the Allen-Bradley PLC-5 the following format must be used.

[O:rg/b] or [I:rg/b]

where

I = Input

O = Output

: = Rack delimiter

r = Assigned rack number

0-3 for PLC-5/12 and PLC-5/15

0-7 for PLC-5/25

g = I/O group number

0-7 for all PLC-5 models

/ = Bit delimiter

b = Terminal (bit) number

0-17 for all PLC-5 models

**Note** To address an I/O word, do not include the /b field

## Status Format

[S:e/b]

**Note** The /b is an optional field

where

S = Status

: = Element delimiter

e = Element number (0-31)

/ = Bit delimiter

b = Bit number (0-15)

**Note** To address a status word, do not include the /b field.

## SLC 500 Word and Bit References

The Allen-Bradley SLC 500 uses decimal word addresses. The PanelMate unit default format is signed 16. The following word and bit addressing descriptions apply to the SLC 500 Command Set.

### General Format

[xf:e.s/b]

**Note** /b is an optional field

where

x = File Type

B - Bit	(signed 16)
N - Integer	(signed 16)
R - Control	(signed 16)
T - Timer	(signed 16)
C - Counter	(signed 16)

**Note** In Counter, Timer, and Control files word 0 is read only, and words 1 and 2 are read/write.

f = File Number

0 - 2	Reserved
3	Bit
4	Timer
5	Counter
6	Control
7	Integer
8	Reserved
9-255	Additional file storage

**Note** The above list of file types are default for Allen-Bradley. They can be changed by the user.

: = Element delimiter

e = Element number

0 - 255 - (in decimal)

. = Subelement delimiter

s = Subelement mnemonic (used with Counter (C), Timer (T), and Control (R) files).

Timer (T):

PRE - Preset Value (word 1)

ACC - Accumulated Value (word 2)

Counter (C):

PRE - Preset Value (word 1)

ACC - Accumulated Value (word 2)

Control (R):

LEN - Length (word 1)

POS - Position (word 2)

/ = Bit delimiter

b = Bit number (not used in word references)

0-4095 - Decimal for Bit (B) type files when element number is not specified (optional)

0-15 - Decimal for Bit (B) and Integer (N) files types

13-15 - Decimal for Timer (T) file types

10-15 - Decimal for Counter (C) or bits 8 through 11

13 and 15 - Decimal for Control (R) file types

Certain file types allow mnemonics to be used instead of the actual bit number. The mnemonic should be placed after the "/" and the "." is not used in this case. The following is a list of mnemonics that can be used.

<u>Bit</u>	<u>Timer (T)</u>
15	EN enable
14	TT timing
13	DN done
0-12	INVALID
<u>Bit</u>	<u>Counter (C)</u>
15	CU up enable
14	CD down enable
13	DN done
12	OV overflow
11	UN underflow
10	UA update accumulator ( not available in the PLC 5)
0-9	INVALID
<u>Bit</u>	<u>Control (R)</u>
15	EN enable
14	EU unload enable
13	DN done
12	EM empty
11	ER error
10	UL unload
9	IN inhibit
8	FD found
0-7	INVALID

## I/O Format

When using the PanelMate unit to access I/O file types in the Allen-Bradley SLC 500 the following format must be used.

[O:e.s/b] or [I:e.s/b]

where

I = Input

O = Output

: = Slot delimiter

e = Slot number

0-2 for SLC 500 model

1-30 for SLC 5/01 or SLC 5/02 models

. = Word delimiter

s = Word number.

0-255 for all SLC 500 models

/ = Bit delimiter

b = Terminal (bit) number

0-15 outbits for SLC 500 model

0-23 input bits for slot 0 for SLC 500 model

0-15 input bits for slot 1 or 2 for SLC 500 model

0-15 input and output bits for SLC 5/01 and SLC 5/02

**Note** A word number is not required if the number of inputs or outputs does not exceed 16 for the slot. If a word number is not given, word zero is assumed.

## Status Format

[S:e/b]

**Note** The /b is an optional field

where

S = Status

: = Element delimiter

e = Element number (0-15)

/ = Bit number

b = Bit number (0-15)

**Note** Words 0, 1, 2, 3, 4, 9, and 10 read only. Words 6, 7, 8, 11, 12, 13, 14, and 15 are read/write.

## Examples

The following are examples of valid PLC references which may be assigned in the PanelMate unit expression fields.

### PLC-2 and PLC-3

#### Word References

<u>Reference</u>	<u>Description</u>
[19]	Word 19
[73]	Word 73
[130]	Word 130

#### Bit References

<u>Reference</u>	<u>Description</u>
[43 07]	Word 43 Bit 7
[66 2]	Word 66 Bit 2
[112 05]	Word 112 Bit 5

## PLC-5

### Word References

<u>Reference</u>	<u>Description</u>
[B321:100]	Element 100 of Bit file 321
[N22:15]	Element 15 of Integer file 22
[d10:891]	Element 891 of BCD file 10
[I:02]	Group 2 in rack 0 of reserved Input file 1
[o:27]	Group 7 in rack 2 of reserved Output file 0
[S:22]	Element 22 in reserved Status file 2
[C222:444]	Control value in element 444 of Counter file 222
[C15:29.ACC]	Accumulated value in element 29 of Counter file 15
[c354:2.PRE]	Preset value in element 2 of Counter file 354
[T31:999]	Control value in element 999 of Timer file 31
[t9:52.aCC]	Accumulated value in element 52 of Counter file 9
[T354:2.pre]	Preset value in element 2 of Counter file 354
[r119:272]	Status value in element 272 of Control file 119
[R53:52.len]	Length value in element 52 of Control file 53
[R111:721.PoS]	Position value in element 721 of Control file 111
[b041:581]	Element 581 of Bit file 41
[n421:008]	Element 8 of Integer file 421
[N009:077#s16]	Element 77 of Integer file 9 (signed 16-bit)
[D10:820#U32]	Element 820 of BCD file 10 (unsigned 32-bit)

### Bit References

<u>Reference</u>	<u>Description</u>
[B34/17]	Bit 17 of Bit file 34 (bit 1 of element 1)
[b4:091/10]	Bit 10 of element 91 of Bit file 4
[N007:25/06]	Bit 6 of element 25 of Integer file 7
[D22:491/15]	Bit 15 of element 491 of BCD file 22
[I:15/7]	Bit 7 in group 5 of rack 1 of Input file 1
[O:32/11]	Bit 11 in group 2 of rack 3 in Output file 0
[s:06/8]	Bit 8 in element 6 of Status file 2
[T9:71.eN]	Enable bit (15) in control word of element 71 of Timer file 9
[t4:1.DN]	Done bit (13) in control word of element 1 of Timer file 4
[T77:32.acc/01]	Bit 1 of accumulated value of element 32 in Timer file 77
[C005:28.UN]	Underflow bit (11) in control word of element 28 of Counter file 5
[c163:08/14]	Down Enable bit (14) in control word of element 8 of Counter file 163
[C88:02.PRE/9]	Bit 9 of preset value of element 2 in Counter file 88
[R6:954.fd]	Found bit (8) in status word of element 954 in Control file 6
[r46:83/09]	Inhibit bit (9) in status word of element 83 in Control file 46
[r518:7.Len/14]	Bit 14 of length value of element 7 in Control file 518

## SLC 500

### Word References

<u>Reference</u>	<u>Description</u>
[B202:100]	Element 100 of Bit file 202
[N22:15]	Element 15 of Integer file 22
[d10:141]	Element 141 of BCD file 10
[I:1.3]	Word 3 of slot 1 of Input file 0
[O:2.1]	Word 1 of slot 2 of Output file 1
[S:22]	Element 22 in reserved Status file 2
[C222:144]	Control value in element 144 of Counter file 222
[C15:29.ACC]	Accumulated value in element 29 of Counter file 15
[c254:2.PRE]	Preset value in element 2 of Counter file 254
[T31:199]	Control value in element 199 of Timer file 31
[t9:52.aCC]	Accumulated value in element 52 of Counter file 9
[T154:2.pre]	Preset value in element 2 of Counter file 154
[r119:172]	Status value in element 172 of Control file 119
[R53:52.len]	Length value in element 52 of Control file 53
[R111:121.PoS]	Position value in element 121 of Control file 111
[b041:81]	Element 81 of Bit file 41
[n21:008]	Element 8 of Integer file 21
[N009:077#s16]	Element 77 of Integer file 9 (signed 16-bit)
[D10:120#U32]	Element 120 of BCD file 10 (unsigned 32-bit)

### Bit References

<u>Reference</u>	<u>Description</u>
[B34/17]	Bit 17 of Bit file 34 (bit 1 of element 1)
[b4:091/10]	Bit 10 of element 91 of Bit file 4
[N007:25/06]	Bit 6 of element 25 of Integer file 7
[D22:191/15]	Bit 15 of element 191 of BCD file 22
[I:1.1/5]	Bit 5 of word 1, slot 1 of Input file 0
[O:2.3/1]	Bit 1 of word 3, slot 2 of Output file 1
[s:06/8]	Bit 8 in element 6 of Status file 2
[T9:71/eN]	Enable bit (15) in control word of element 71 of Timer file 9
[t4:1/DN]	Done bit (13) in control word of element 1 of Timer file 4
[T77:32.acc/01]	Bit 1 of accumulated value of element 32 in Timer file 77
[C005:28/UN]	Underflow bit (11) in control word of element 28 of Counter file 5
[c163:08/14]	Down Enable bit (14) in control word of element 8 of Counter file 163
[C88:02.PRE/9]	Bit 9 of preset value of element 2 in Counter file 88
[R6:154/fd]	Found bit (8) in status word of element 154 in Control file 6
[r46:83/09]	Inhibit bit (9) in status word of element 83 in Control file 46
[r118:7.LeN/14]	Bit 14 of length value of element 7 in Control file 118

## Access Permitted by Maintenance Template

---

The Maintenance Template will access all memory locations supported by the PLC driver as defined in this chapter. When running online, you may change the PLC reference. The Maintenance Template is designed to assist you in specifying the PLC reference by scrolling through a list of mnemonics which are used to enter the PLC word reference. When online in the PLC reference change mode, the following list is available.

PLC-5	"O:", "I:", "S:", "B", "T", "C", "R", "N", "D", ":", "/", ".ACC", ".PRE", ".POS", ".LEN", ".ER", ".DN", ".EN", ".TT", ".CU", ".CD", ".OV", ".UN", ".EU", ".EM", ".UL", ".IN", and ".FD"
SLC 500	"O:", "I:", "S:", "B", "T", "C", "R", "N", ":", "/", ".ACC", ".PRE", ".POS", ".LEN", "/ER", "/DN", "/EN", "/TT", "/CU", "/CD", "/OV", "/UN", "/UA", "/EU", "/EM", "/UL", "/IN", and "/FD"

You must enter the correct mnemonics and numeric values and create a legal reference to change a PLC reference. Once a new reference is entered, the Maintenance Template will remain in a paused state until the control button labeled "Start Monitor" is depressed. The PanelMate Series 1000 will then parse the reference. (Parsing means checking the syntax and range of the reference to ensure that it is supported by the driver.) If correct, the template begins updating.

# Allen-Bradley Remote STS and EXT STS Errors

The most common remote errors reported by the Allen-Bradley PLCs are listed in the following tables. If you are using Allen-Bradley PLCs for Data Highway or Data Highway Plus, a complete set of error codes can be found in the Allen-Bradley Publication 1770-6.5.16, November 1991. Take note of the hexadecimal error code and consult the Allen-Bradley publication. If the remote error code is F0XX (hex), then the XX represents the Allen-Bradley EXT STS (extended status) error code. The EXT STS codes are found in the EXT STS Codes for Command Code 0F (hex) table. Other remote error codes are found in the Remote STS Error Codes table.

Error Number	Description
00	Success -- no error
10	Illegal command or format
20	Host has a problem and will not communicate
30	Remote node host is missing, disconnected, or shut down
40	Host could not complete function due to hardware fault
50	Addressing problem or memory protect rungs
60	Function disallowed due to command protection selection
70	Processor is in program mode
80	Compatibility mode file missing or communication zone problem
90	Remote node cannot buffer command
A0	Not used
B0	Remote node problem due to download
C0	Cannot execute command due to active IPBs
D0	Not used
E0	Not used
F0	There is an error code in the EXT STS byte

Table 29-5 Remote STS Error Codes

You will have an EXT STS byte if your STS codes is F0 (hex). The EXT STS has different definitions depending on the command code (type of command) in your message packet. If the command code is:

- 00 to 08 (hex)                      There is not an EXT STS byte.
- 0E or 0F (hex)                      These are Data Highway/Data Highway Plus codes.
- 0B, 1A, or 1B (hex)                These are DH-485 codes.

Error Number	Description
0	Not used
1	A field has an illegal value
2	Less levels specified in address than minimum for any address
3	More levels specified in address than system supports
4	Symbol not found
5	Symbol is of improper format
6	Address does not point to something usable
7	File is wrong size
8	Cannot complete request, situation has changed since the start of the command
9	Data or file is too large
A	Transaction size plus word address is too large
B	Access denied, improper privilege
C	Condition cannot be generated - resource is already available
D	Condition already exists -- resource is already available
E	Command cannot be executed
F	Histogram overflow
10	No access
11	Illegal data type
12	Invalid parameter or invalid data
13	Address reference exists to deleted area
14	Command execution failure for unknown reason; possible PLC-3 histogram overflow
15	Data conversion error
16	Scanner not able to communicate with 1771 rack adapter
17	Adapter cannot communicate with module
18	1771 module response was not valid
19	Duplicated label
1A	File is open; another node owns it
1B	Another node is the program owner
1C to FF	Not used

Table 29-6 Remote EXT STS Error Codes





# Chapter 30

## The AcceleratI/On Interface

---

The AcceleratI/On interface is a separate product which is compatible with the PanelMate Series 1000. An AcceleratI/On interface may be installed in a PanelMate unit to provide communication to Allen-Bradley PLCs through Data Highway, Data Highway Plus, or the remote I/O network.

The interface provides several distinct advantages:

- With AcceleratI/On, the PanelMate unit can connect directly to Data Highway, Data Highway Plus, or the Remote I/O network without requiring additional communication modules.
- The direct connection just noted eliminates the need for serial RS232 connections, permitting data to transfer at 57.6K baud for Data Highway and Data Highway Plus, and 57.6K baud, 115.2K baud, 230.4K baud for Remote I/O.
- When it is connected to the remote I/O network, a unique monitor function permits the PanelMate unit with AcceleratI/On to read discrete inputs, outputs, or block transfers directly off the I/O link without requiring the PLC to transmit the data to the PanelMate unit.

When AcceleratI/On is used as an interface to Data Highway or Data Highway Plus, the PanelMate unit functions as a master - polling one or more PLCs on the network to obtain or transmit data.

When AcceleratI/On is used as an interface to the Remote I/O network, the PanelMate unit simulates one or more remote racks. Each rack can be split into a quarter rack or any multiples of a quarter rack (i.e., 1/4, 1/2, 3/4 or full rack). The PLC can use normal I/O scan or block transfer operations to read or write data to or from the PanelMate unit, as though the interface was a rack. As with any Remote network, the PLC will be the master while the PanelMate unit will be a slave.

## Possible Configurations

The Accelerat/On interface may be used to communicate to a Data Highway, Data Highway Plus, or Remote I/O network. The interface may be configured for only one of these communication types at any one time.

**Note** If the Accelerat/On interface is used, the PanelMate unit's serial port is not available for use.

Examples of possible configurations are described in the following sections.

### Direct Data Highway Connections

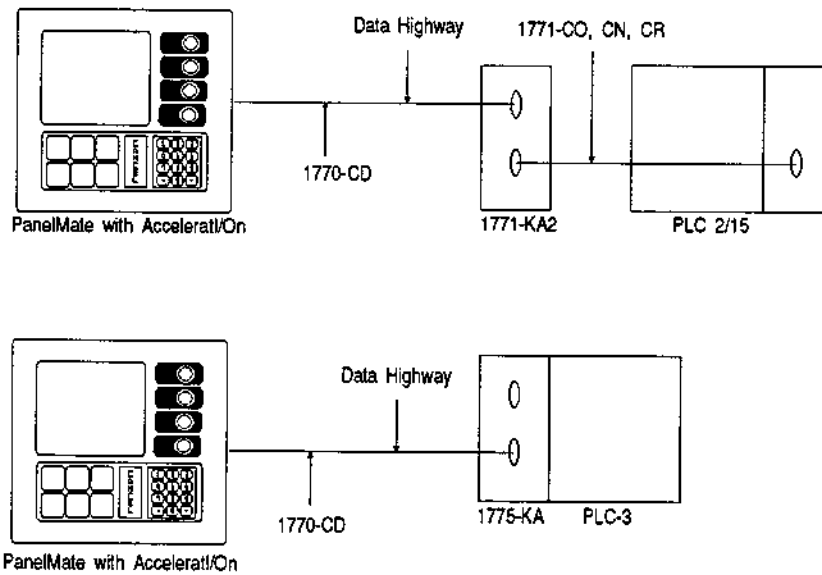


Figure 30-1 Direct Data Highway Connections

## Multiple Data Highway Connections

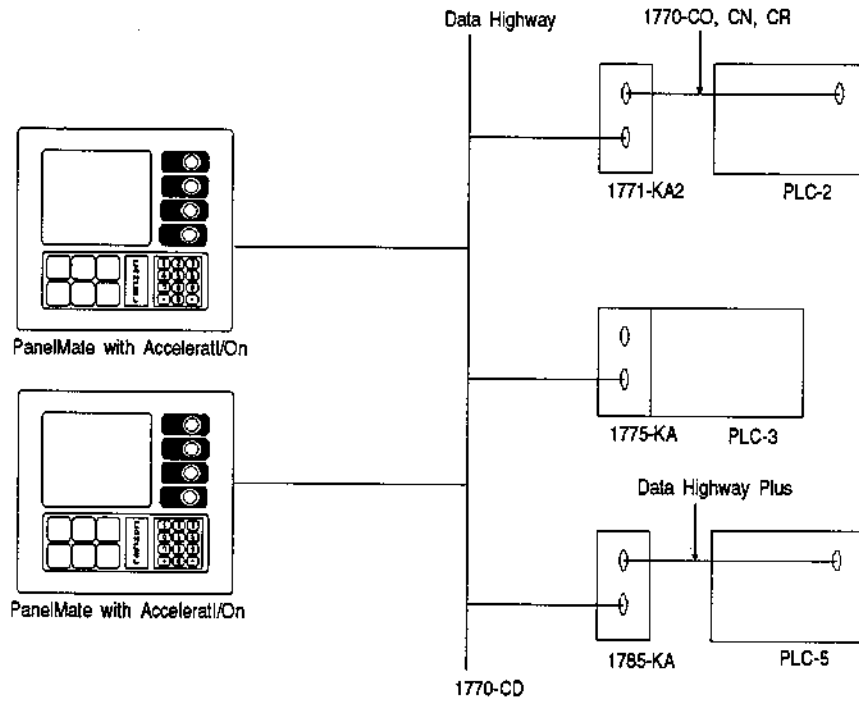


Figure 30-2 Multiple Data Highway Connections

## Direct Data Highway Plus Connections

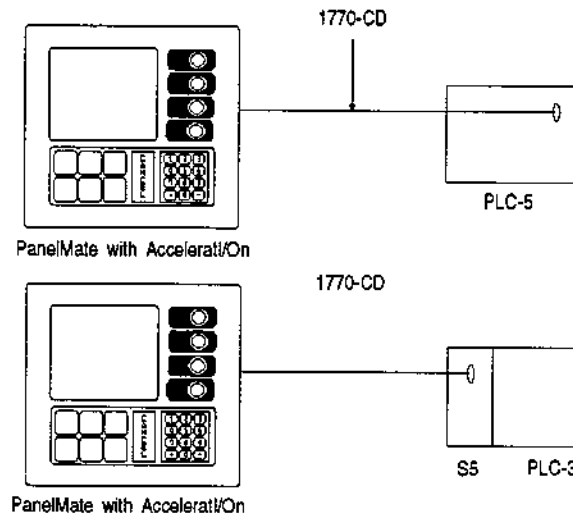


Figure 30-3 Direct Data Highway Plus Connections

# Multiple Data Highway Plus Connections

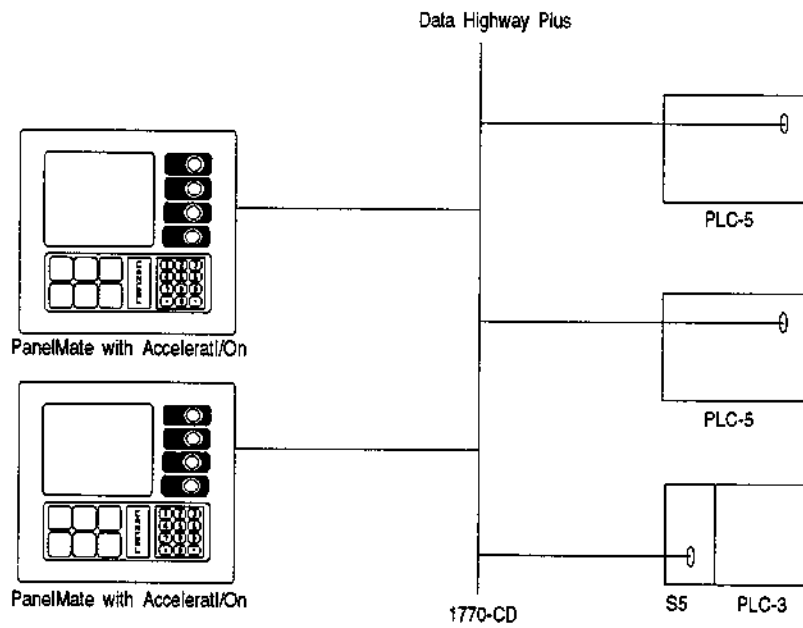


Figure 30-4 Multiple Data Highway Plus Connections

## Direct Data Highway and Data Highway Plus Connections

The PanelMate unit on a Data Highway can access all nodes on Data Highway and Data Highway Plus.

**Note** The PanelMate unit on the Data Highway Plus network cannot access nodes on the Data Highway, only nodes on the Data Highway Plus are accessible.

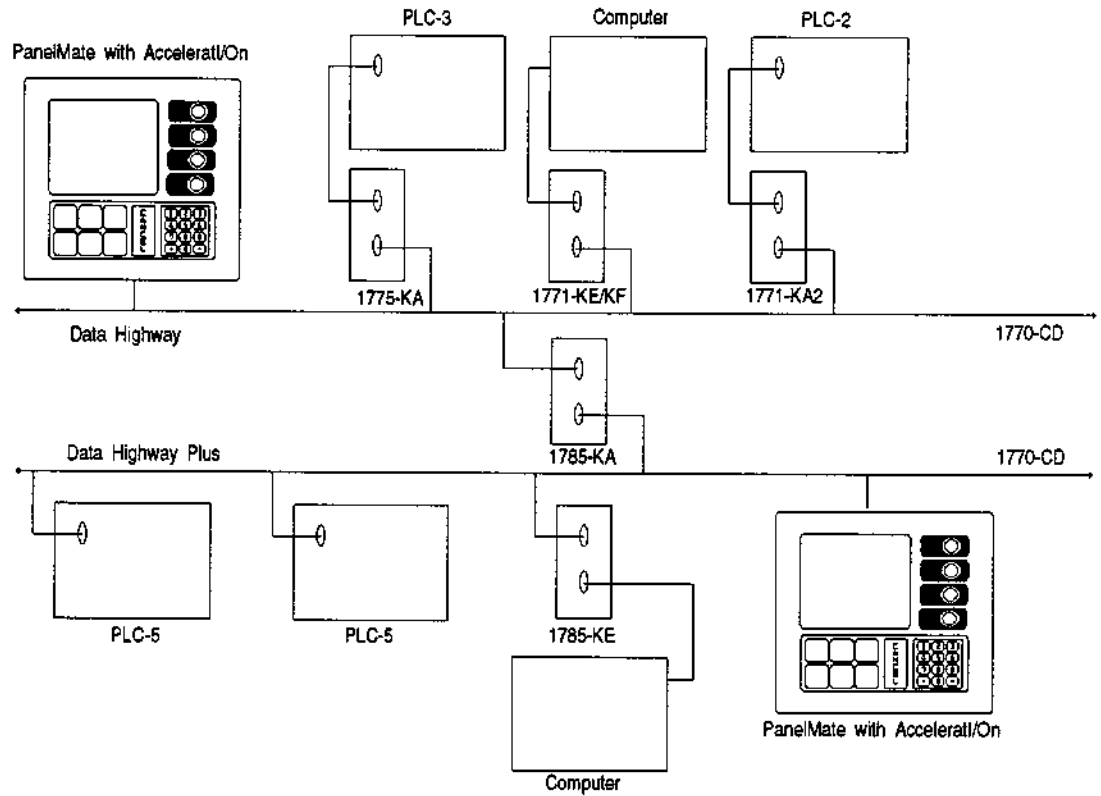


Figure 30-5 Direct Data Highway and Data Highway Plus Connections

# Remote I/O Connections

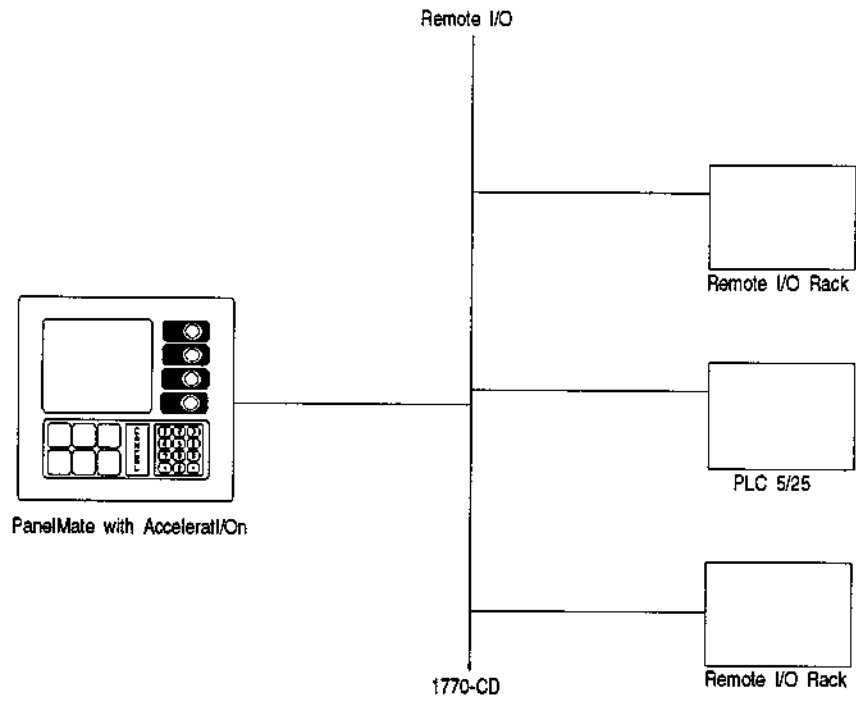


Figure 30-6 Remote I/O Connections

# Cabling

The same connection guidelines recommended for any Data Highway, Data Highway Plus, or Remote I/O device should be used for connecting a PanelMate unit to any of these networks. Standard 1770-CD twinaxial cable or equivalent should be used. A minimum cable length of 20 feet between nodes should be observed. Proper network termination procedures should be observed.

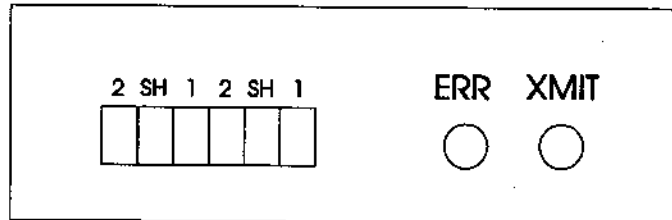


Figure 30-10 Network Connection on Accelerat/On Interface

Network connections for the Accelerat/On interface are on the back of the PanelMate Series unit.

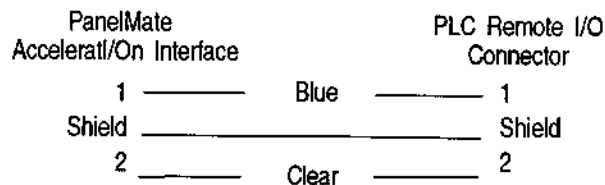
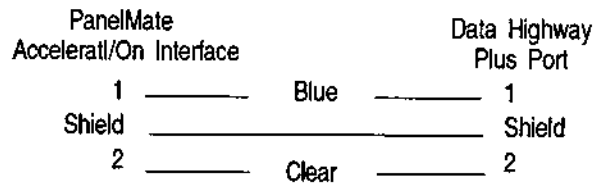
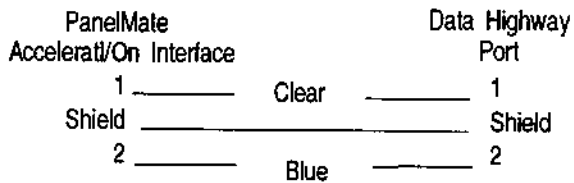


Figure 30-8 Cabling Diagrams

Two sets of electrically-common network connections are provided: 1, Shield, 2. A six-position female connector is shipped with each interface. Cabling connections are made to this female connector. The connector is then attached to the Accelerat/On interface.

A 150-ohm or 82-ohm resistor should be attached to the female connector for proper termination when required. Consult Allen-Bradley documentation for information regarding correct termination of Data Highway, Data Highway Plus, or Remote I/O networks.

In general, the following rules apply: If the Accelerat/On interface is the end node on a network, the supplied 150-ohm resistor is needed. If the interface is not the end node on the network, the resistor is not needed.

## Communication Parameters

The PanelMate unit's Accelerat/On interface can be used with a network communication rate of 57.6K baud for Data Highway and Data Highway Plus, and 57.6K baud, 115.2K baud, or 230.4K baud for Remote I/O. The desired rate is selected in the PLC and Port Parameters utility.

See the proper Allen-Bradley documentation for information on setting the communication rate for other network devices.

## Modules for SLC 5/02 Remote I/O Communication

### 1747 SN

The 1747 SN module allows up to four additional remote I/O racks. These racks are numbered from 0-3. Each rack provides eight input and eight output words.

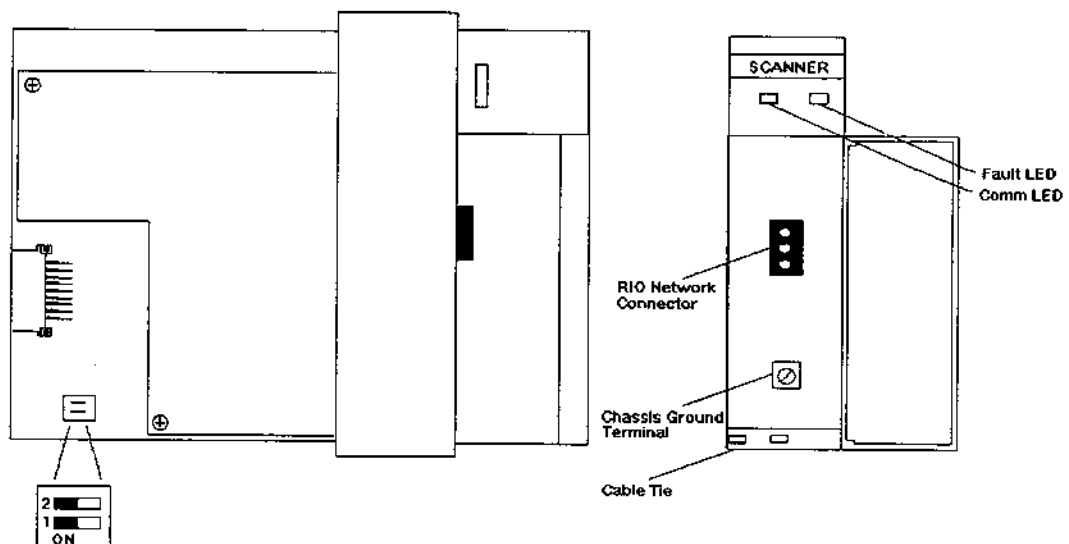


Figure 30-9 1747 SN Scanner Module

The switch positions for setting the baud rate are listed in the following table.

<u>Baud Rate</u>	<u>Switch 1</u>	<u>Switch 2</u>
57.6 KBaud	ON	ON
115.2 KBaud	ON	OFF
230.4 KBaud	OFF	ON
230.4 KBaud	OFF	OFF

**Table 30-1 Baud Rate Table**

When configuring the local rack, if the 1747 SN module is not currently a selection in the software package, enter the number 13608 as the Module Code ID. For details on configuring your module, consult the 1747 SN User's Manual or Cutler-Hammer IDT's technical note, the PanelMate Series Communications to an Allen-Bradley SLC 5/02 - Remote I/O.

**Note** The 1747 SN module will not allow block transfers to any device including the PanelMate units.

## **Diagnostic Indicators**

---

The Accelerat/On interface has two diagnostic indicator lights near the network connector. (Refer to figure 30-7.)

The green indicator is labeled "TRANSMIT." It will remain off when the PanelMate unit is in Configuration Mode. When the PanelMate unit goes online, the light will flash rapidly after network communication has been established.

The red indicator is labeled "ERROR." It will remain on when the PanelMate unit is in the Configuration Mode. When the PanelMate unit goes online, the light will go off to indicate proper initialization of the interface. A red light which stays on during Run Mode indicates a problem with the Accelerat/On hardware. If you have installed the interface, check installation of the circuit board in the Electronics Module. If the installation appears correct or if the interface was installed by Cutler-Hammer IDT, call Customer Service at (614) 882-3282.

## Allen-Bradley Word and Bit References

---

The following section describes the use of Allen-Bradley word and bit references in your configuration. The general word referencing method is:

[plcname,word#format]

The "plcname" is the name of the designated PLC as listed in the PLC Name and Port Table. The "word" is the reference number (address) of the word or register to be read or written. The "#format" is a code which specifies the format of the data being read or written. The "plcname" and "#format" are optional.

The general bit referencing method is:

[plcname,bit]

The "plcname" is the designated PLC as listed in the PLC Name and Port Table. The "bit" is the reference number (address) of the bit, coil, or input to be written or read.

See chapter 10 for a more detailed explanation of word and bit references, including format descriptions.

## Data Highway and Data Highway Plus

---

When a PanelMate unit with Accelerat/On is communicating to Data Highway or Data Highway Plus, it is a master. The PanelMate unit can accept unsolicited write messages from a PLC through the Data Highway or Data Highway Plus networks. See chapter 29 for information regarding Allen-Bradley word and bit addresses and their use in the PanelMate template editors for Data Highway/Data Highway Plus applications.

## Remote I/O

---

The following subsections describe the reference formats for Input and Output memory, the reference formats for monitored and active block transfer memory, along with error messages which may be displayed.

**Note** All numbers used for PLC addressing in remote I/O references are in octal.

## Monitored I/O

The Allen-Bradley Remote I/O Networks allow devices to address input and output registers. The following addressing format will be used:

[T:RG/BB]

where:

T	File type (I=input or O=output)
:	Type separator
R	Rack number (1-7 octal for PLC-2) (0-37 octal for PLC-3) (1-3 octal for PLC-5/15) (1-7 octal for PLC-5/25) (0-3 octal for SLC 5/02)
G	Group number (0-7)
BB	Bit specifier (0-17 octal, 2-digit maximum)

Example: [I:10/0]

PanelMate units will reference input bit 0 in rack 1, group 0, slot 0.

For a PLC-2, PLC-5/15, PLC-5/25, and SLC 5/02, the maximum rack number can be contained within one octal digit. The first character after the file type separator character ":" is the rack number. Since a PLC-3 may have more than eight racks, the rack number may be comprised of two octal digits. If three octal digits are entered consecutively after the file type separator, the rack number is assumed to be the first two octal digits and the group number is assumed to be the third octal digit.

## Active Block Transfer Referencing

Active block transfers and monitored block transfers are different in that active block transfers have the ability to move data to the PLC from the PanelMate unit as shown in figure 30-13. Active block transfers must be configured in the Allen-Bradley Remote I/O Configuration Table to avoid any errors. The PanelMate unit will allow addressing to any word within the referenced active block transfer. Since the active block transfers have been configured beforehand, a slightly different method of referencing will be used, allowing the active block transfer ID to be used much like a macro substitution in place of the rack-group-slot.

**Note** It is not recommended to use the PanelMate unit's input or output addresses in a slot where active block transfers have been configured.

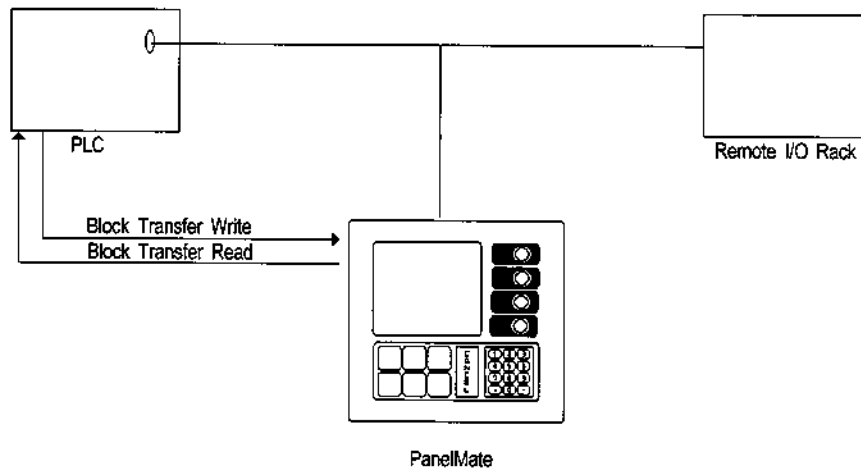


Figure 30-10 Active Block Transfers

The following addressing format will be used:

[B:D WW/BB]

where:

- B Active block transfer specifier
- :
- D Transfer ID ("A-P" character designator from Active Block Transfer Table)
- ' '
- Block separator (only one space is allowed)
- WW Word offset (0-77 octal, 2-digit maximum, the maximum value determined by block transfer size)
- /
- Bit separator
- BB Bit offset (0-17 octal, 2-digit maximum)

Example: [B:A 1/0]

The PanelMate unit will reference bit 0 of word 1 in active block transfer "A" (block transfer "A": configured in the remote I/O configuration).

**Note** The Transfer ID is configured from the Active Block Transfer Table in the Allen-Bradley Remote I/O Configuration Editor accessible from the PLC Name and Port Table.

## Monitored Block Transfer Referencing

A block transfer causes a block of data to move between an I/O module and a PLC data file. In the Accelerat/On interface, block transfers are stored in data buffers and saved on a rack-group-slot basis. Any block transfer that occurs on the bus will be buffered by the interface card, and any word within the monitored block transfer buffer can be read by the PanelMate unit. There are two sets of block transfer data buffers: one for block transfer reads and one for block transfer writes.

**Note** Block transfers can only be monitored from remote racks.

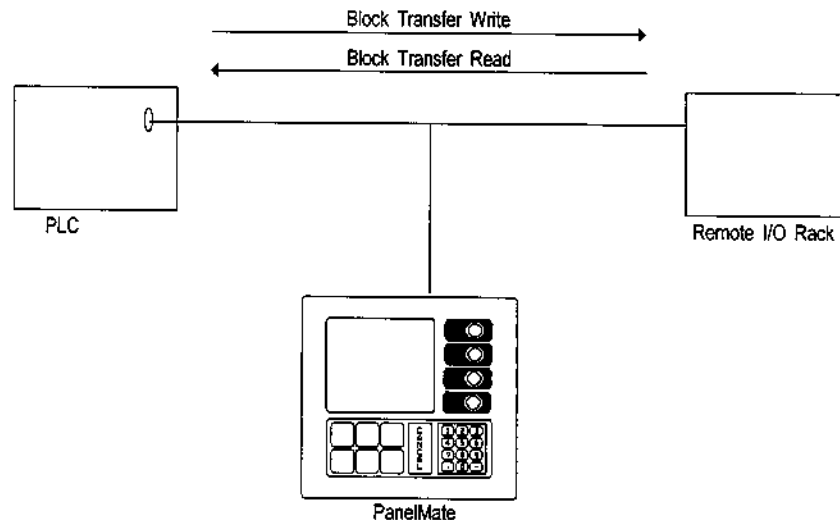


Figure 30-11 Monitored Block Transfers

The following addressing format will be used:

[T:RGS WW/BB]

where:

- T Type (R = block read, W = block write)
- :
- R Rack number
  - (1-7 octal for PLC-2)
  - (0-37 octal for PLC-3)
  - (1-3 octal for PLC-5/15)
  - (1-7 octal for PLC-5/25)
  - (0-3 octal for SLC 5/02)
- G Group number (0-7)
- S Slot number (0 or 1)
- ' ' Block separator (only one space is allowed)
- WW Word offset (0-77 octal, 2-digit maximum)
- / Bit separator
- BB Bit offset (0-17 octal, 2-digit maximum)

Example: [R:100 1]

The PanelMate unit will reference word 1 of the block transfer read going to the PLC from the module that is in rack 1, group 0, slot 0.

For a PLC-2, PLC-5/15, PLC-5/25, and SLC 5/02, the maximum rack number can be contained within one octal digit; thus, the first character after the file type separator character ":" is the rack number. Since a PLC-3 may have more than eight racks, the rack number may be comprised of two octal digits. If three octal digits are entered consecutively after the file type separator, then the rack number is assumed to be the first octal digit, the group number is assumed to be the second octal digit and the slot number is assumed to be the third octal digit. If four octal digits are entered consecutively after the file type separator, then the rack number is assumed to be the first two octal digits, the group number is assumed to be the third octal digit, the slot number is assumed to be the fourth octal digit.

### **Control Button Reset Delay**

During Run Mode operation, operators can use the PanelMate unit's control button feature to emulate momentary pushbuttons. When an operator presses a control button, the PanelMate unit sets the assigned bit on the AcceleratI/On interface so that the bit can be read by the remote I/O scan cycle. When the operator releases the control button, the PanelMate unit clears the assigned bit on the AcceleratI/On interface.

In order to ensure that the bit on the AcceleratI/On interface is in a set condition long enough to be read by the I/O scan, the PanelMate unit provides a method to delay resetting the bit. The Control Button Reset Delay feature noted in Chapter 23, PLC Name and Port Parameters Table, provides a method of delaying bit reset by multiples of 250 milliseconds.

### **Active Racks**

---

An active rack is a rack that does not physically exist but rather is being simulated by the PanelMate unit interface. Simulating a rack or multiple of a quarter rack is the only way for the PanelMate unit to write data to the PLC.

The PanelMate unit is capable of simulating racks on the bus as well as monitoring the other racks' data. This is very important since the only way for the PanelMate unit to write to the PLC is through a simulated rack. Refer to table 30-2 for possible rack addresses. The PanelMate unit interface card can simulate any or all available unused racks, but must not attempt to simulate rack addresses for racks that physically exists. If a physical rack is being simulated, both the PanelMate unit and the physical rack will respond to any messages, causing invalid data to be sent to the PLC.

**Note** Although a PLC-3 can have 63 racks, the PanelMate unit has configuration tables sized for 32 racks; since the interface board can only monitor a single channel on the PLC-3, only 16 racks can be simulated or monitored.

The Allen-Bradley Remote I/O Configuration Editor contains a section called the Active Rack Table which will be used when configuring the active racks. Since the maximum number of racks that can be addressed is dependent upon the PLC type, it will be necessary to enter the Remote I/O PLC model first in the PLC Name and Port Table before proceeding to the Allen-Bradley Remote I/O Configuration Editor. Refer to the Remote I/O Configuration section in Chapter 23, for more information on configuring the PanelMate unit with Remote I/O.

The following table shows the addressable racks for each PLC model.

<u>PLC Type</u>	<u>Number of Racks</u>		<u>Range</u>
	<u>Octal</u>	<u>Decimal</u>	
PLC-2	7	7	1-7
PLC-3	37	32	0-37
PLC5/15	3	3	1-3
PLC5/25	7	7	1-7
SLC 5/02	3	3	0-3

**Table 30-2 Rack Addresses**

The following write restrictions will apply:

- Cannot write to an output reference
- Can only write to input references if the reference's rack is active (set as active in Active Rack Table)
- Cannot write to monitored block transfers (both read and write)
- Can only write to active block transfer references with a direction of READ or COMMON

## **Block Transfers**

Many of Allen-Bradley's PLC modules support block transfers. These modules generally have more than one word of information per slot, and block transfers are the only convenient way of moving data between these modules and the PLC. The data is moved from the module into a data file within the PLC. One block transfer can move up to 64 words of data, the block transfer specified by giving the rack, group and slot. Block transfers only occur when the PLC is programmed to use them. To implement a block transfer, a block transfer read (BTR) or block transfer write (BTW) instruction is placed on one of the ladder logic rungs. The instruction will specify the rack-group-slot for the transfer as well as the number of words, file and starting element number.

The PanelMate unit's interface card supports two types of block transfers (monitored and active). For monitored block transfers, the PanelMate unit will monitor all block transfers being sent from the PLC to the various racks and keep one read and one write per slot. For active block transfers, the PanelMate unit is capable of sending and receiving block transfer reads and writes for racks that have been made active. To accomplish this, the size and location of all active block transfers to be executed by an active rack must be specified before communications start. Active block transfers must still be programmed into the PLC for any data exchanges to take place.

## Block Transfer Examples

### Possible Block Transfer Write Example (PLC-5/15)

The following rung will continually block transfer write to the PanelMate unit assigned as active rack #3.

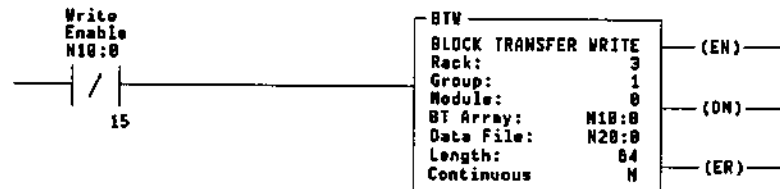
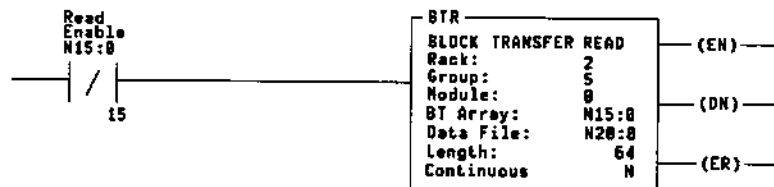


Figure 30-12 Block Transfer Write

### Possible Block Transfer Read Programming (PLC-5/15)

The following rung will continually block transfer read from the PanelMate unit assigned as active rack #2.



Move Read File to "Verified" Read File

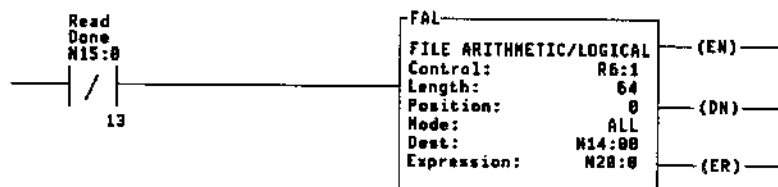


Figure 30-13 Block Transfer Read

The PLC program should use verified read data. When moving data from one type of data table section to another, the FAL instruction will convert the data format (such as integer to BCD). If this is not desired, use the File Copy instruction.

### Possible Recipe Example Using Block Transfers (PLC-5/15)

(Assuming the PanelMate unit is configured as rack 1, group 0, slot 0, and direction is COMMON.)

In this example a standard recipe is stored in N30. It is block transfer written to a common block transfer area in the PanelMate unit. Once adjustments are made to the recipe, it is Block Transfer read into N20. The data block transfer is moved to N40 which now contains the modified recipe.

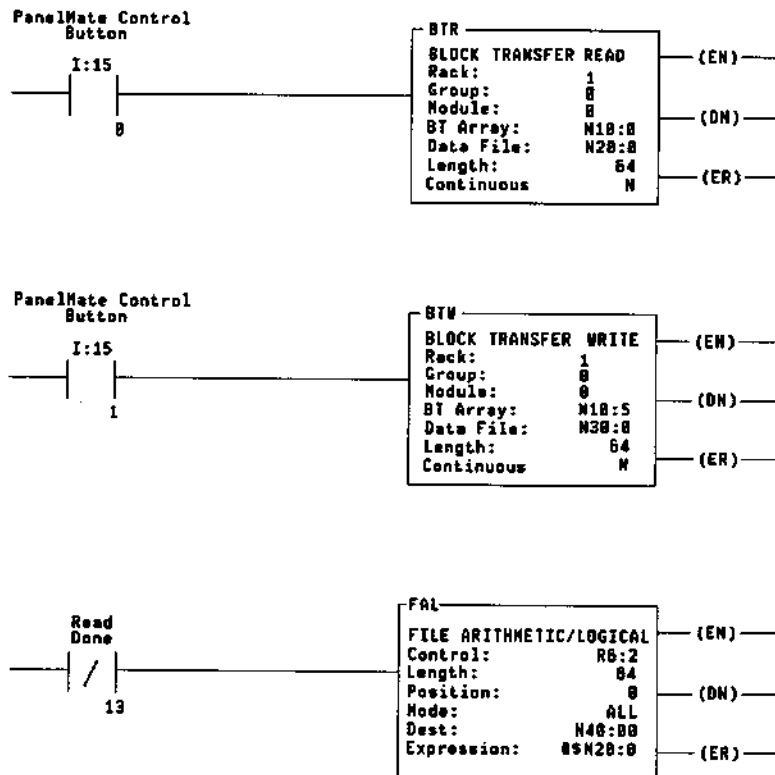


Figure 30-14 Recipe Example Using Block Transfers

## Possible Continuous Bi-directional Block Transfer Example (PLC-2)

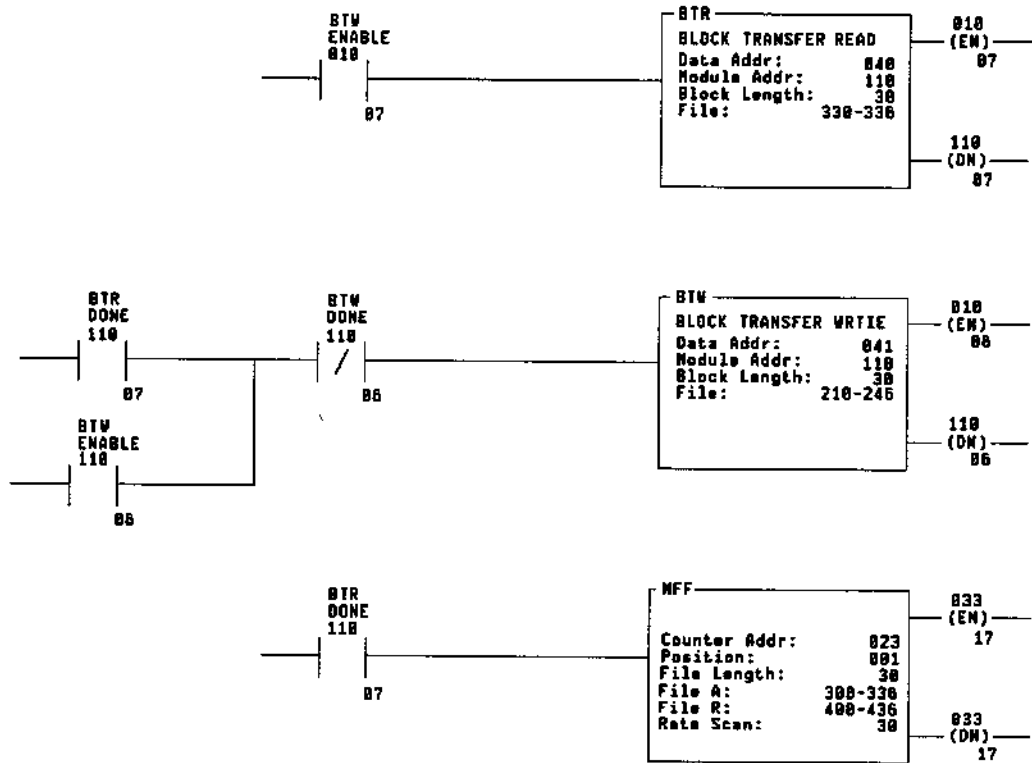


Figure 30-15 Continuous Bi-directional Block Transfer

### Block Transfer Discussions

#### Active Block Transfer Sent to Inactive Rack

If the PLC sent a block transfer to a rack that was not active (and did not physically exist), an error would exist in the PLC since no rack would be responding to the block transfer; the Accelerati/On interface would ignore the block transfer.

#### Active Block Transfer Write Error

If the PanelMate unit is configured for a write (or common) block transfer, but has not received one from the PLC, a non-fatal communication error will occur. Once the PanelMate unit receives the block transfer, the error will cease and no other errors will follow.

For example, a one-shot block transfer write occurring before the PanelMate unit is initialized online.

### Active Block Transfer Read Error

An error will be generated only when a block transfer read is invalid. However, no error will be displayed when the PanelMate unit is configured for a block transfer read and the PLC does not execute a block transfer read or if the block transfer read occurred before the PanelMate unit is initialized online.

### Block Transfer Buffer Allocation

The PanelMate unit can buffer up to 128 block transfers (both active and monitored). The interface card allocates 128 bytes (64 words) for each monitored block transfer regardless of the size of the actual block transfer. Although it is highly unlikely, it is possible for more than 128 block transfers to be configured or monitored. In this case, any new block transfer (one that has not already been buffered) received after the first 128 block transfers will not be buffered. It is also possible that enough large block transfers could be active and monitored that the interface card may run out of enough memory to store them. In both of these circumstances, if the PanelMate unit makes a request for data within a block transfer which is not currently stored in the interface board block transfer buffer, then a non-fatal communication error will result. Since block transfer buffers will never be deallocated (the interface board would have to be reconfigured), there is no online recovery from these errors. To recover from the errors, you must re-boot the system.

### Monitored Block Transfer

It may be possible, particularly during the bit initialization or during the initial page display after Run Mode initialization, that various references to monitored block transfers will be in error since the I/O board has not yet monitored the block transfers containing the requested information. Non-fatal communication errors will continue until the Accelerat/On board has monitored the required block transfers.

## Unsolicited Write Message

The PanelMate unit can accept unsolicited write messages (message instruction) from a PLC through the Data Highway or Data Highway Plus networks when using the Accelerat/On option.

Unsoliciteds should only be used for priority information transfer. If the PanelMate unit receives an unsolicited message from a PLC, the normal polling will be interrupted and the unsolicited message will be immediately processed. Once completed, the PanelMate unit's normal polling will resume.

In the PLC's perspective, the PanelMate unit will be seen as another PLC on the network. Command code "Remote Station No." must be the PanelMate unit's Network ID. The PanelMate unit supports only protected and unprotected writes. Note that the Command zone rung must be first.

The following are examples of unsolicited writes to the PanelMate unit.

For remote station data table address, the PanelMate unit normal addressing restrictions apply.

Refer to the proper Allen-Bradley manual for further unsolicited message configuration.

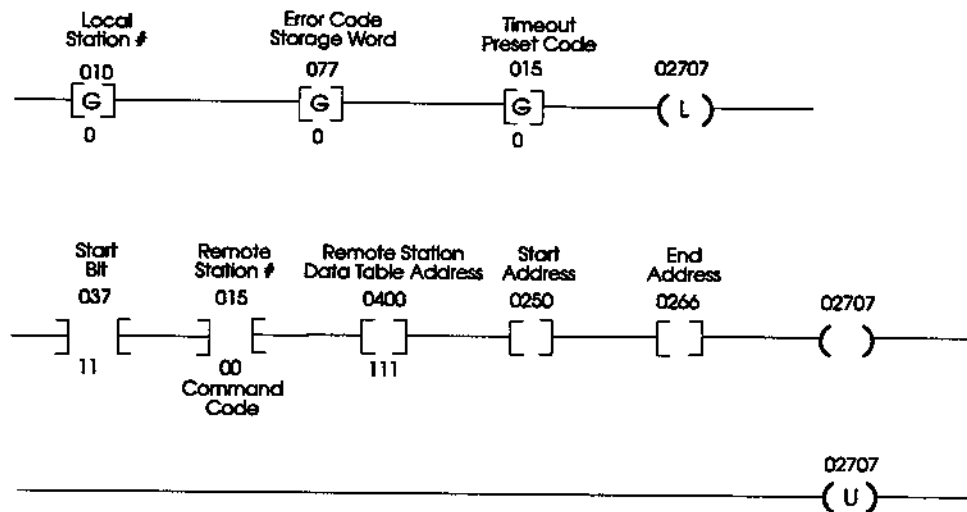
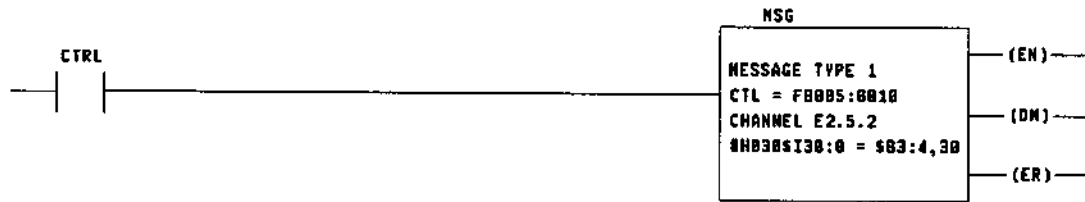


Figure 30-16 Network Connection on Accelerat/On Interface

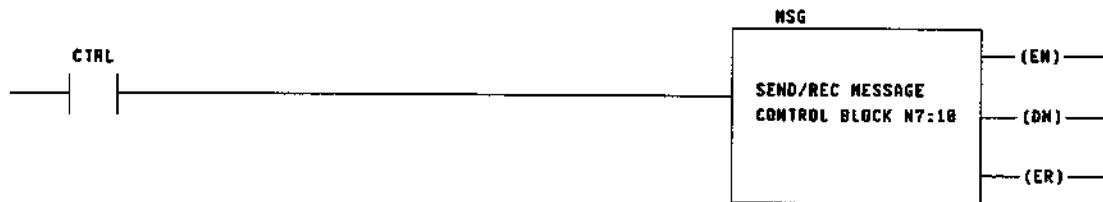


**Figure 30-17 PLC3 Message Instruction (Write Only)**

**Note** The destination address must be an input image file that matches the PanelMate unit's Network ID.

Example:

\$I30:0      PM Network ID = 30



**Figure 30-18 PLC5 Message Instruction (Write Only)**

**Note** The message instruction's destination address must use file address of N7 and be a valid reference in the PanelMate unit. A reference in a Maintenance template will not update via an unsolicited write.

**Note** Do not use leading zeroes in references intended to update via an unsolicited write (e.g., use N7:5 instead of N7:05).

Message must be write only because the PanelMate unit can only receive unsolicited.

## Access Permitted by Maintenance Template

The Maintenance Template will access all memory locations supported by the PLC driver as defined in this chapter. When running online, you may change the PLC reference. The Maintenance Template is designed to assist you in specifying the PLC reference by scrolling through a list of mnemonics which are used to enter the PLC word reference. When online in the PLC reference change mode, the following list is available.

PLC-5	"O:", "I:", "S:", "B", "T", "C", "R", "N", "D", ":", "/", ".ACC", ".PRE", ".POS", ".LEN", ".ER", ".DN", ".EN", ".TT", ".CU", ".CD", ".OV", ".UN", ".EU", ".EM", ".UL", ".IN", and ".FD"
SLC 500	"O:", "I:", "S:", "B", "T", "C", "R", "N", ":", "/", ".ACC", ".PRE", ".POS", ".LEN", "/ER", "/DN", "/EN", "/TT", "/CU", "/CD", "/OV", "/UN", "/UA", "/EU", "/EM", "/UL", "/IN", and "/FD"

You must enter the correct mnemonics and numeric values and create a legal reference to change a PLC reference. Once a new reference is entered, the Maintenance Template will remain in a paused state until the control button labeled "Start Monitor" is depressed. The PanelMate Series 1000 will then parse the reference. (Parsing means checking the syntax and range of the reference to ensure that it is supported by the driver.) If correct, the template begins updating.

**Note** A reference in a Maintenance template will not update via an unsolicited write.

Note that this product incorporates patented technology which is licensed by Allen-Bradley Company, Inc. Allen-Bradley has not technically approved, nor does it warrant or support this product. All warranty and support for this product is provided by Cutler-Hammer IDT, Inc.





# Chapter 31

## Cutler-Hammer PLCs

---

The PanelMate Series 1000 supports the use of the Cutler-Hammer D500 (models CPU20, CPU25, and CPU50) and D200 PR4C Programmable Logic Controllers (PLCs).

Up to eight PLCs can be connected to one PanelMate unit by using the current protocol.

# Memory

---

The Cutler-Hammer D500 family (models CPU20, CPU25, and CPU50) and the D200 PR4C processor use decimal word addresses.

The following list contains descriptions of the memory types:

<u>Memory Type Symbol</u>	<u>Description</u>
X (Read only)	Input device (bit)
XW (Read only)	Input register
Y	Output device (bit)
YW	Output register
R	Control relay device (bit)
RW	Control relay register
Z	Remote link storage device (bit)
ZW	Remote link storage register
C	Counter register
T	Timer register (max. value 32767)
D	Data register

The following list contains descriptions of the memory ranges:

		Devices or Registers		
		CPU20	CPU25	CPU50/D200 PR4C
X or Y	Device	X or Y 000-15F (256 devices)	X or Y 000-15F (256 devices)	X or Y 000-31F (512 devices)
	Register	XW or YW 00-31 (32 registers)	XW or YW 00-31 (32 registers)	XW or YW 00-63 (64 registers)
Z	Device	Z000-Z31F (512 devices)	Z000-Z31F (512 devices)	Z000-Z31F (512 devices)
	Register	ZW00-ZW31 (32 registers)	ZW00-ZW31 (32 registers)	ZW00-ZW31 (32 registers)
R *	Device	R000-R63F (1024 devices)	R000-R63F (1024 devices)	R000-R63F (1024 devices)
	Register	RW00-RW63 (64 registers)	RW00-RW63 (64 registers)	RW00-RW63 (64 registers)

		Registers Only		
		CPU20	CPU25	CPU50/D200 PR4C
XW or YW	Register	XW or YW 16-31 (16 registers)	XW or YW 16-31 (16 registers)	XW or YW 32-63 (32 registers)
T	Register	T000-T127 (128 timers)	T000-T127 (128 timers)	T00-T127 (128 timers)
C	Register	C00-C95 (96 counters)	C00-C95 (96 counters)	C00-C95 (96 counters)
D	Register	D0-D1535 (1536 registers)	D0-D1535 (1536 registers)	D0-D1535 (1536 registers)
<p>* Devices R600-R63F (registers RW60-RW63) are reserved for special functions. Data should not be altered in these locations.</p>				

**Table 31-1 Memory Ranges**

# Possible Configurations

Examples of possible connections are described and shown in the following sections.

## Direct

Direct connection to a CPU20 using the computer interface terminals, or to a CPU25 or CPU50 using the computer interface board (D500CIB99).

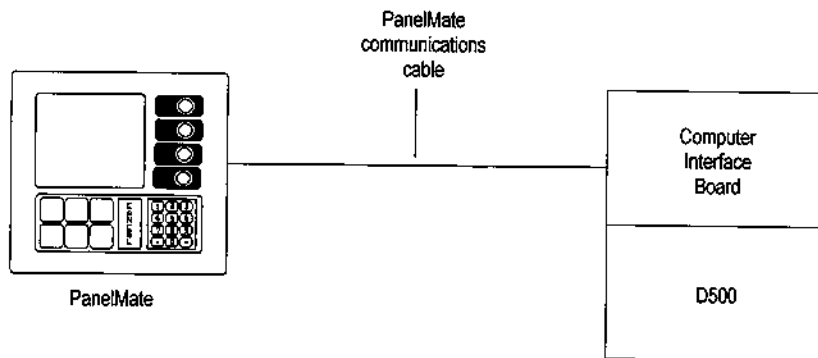


Figure 31-1 Single PLC Connection

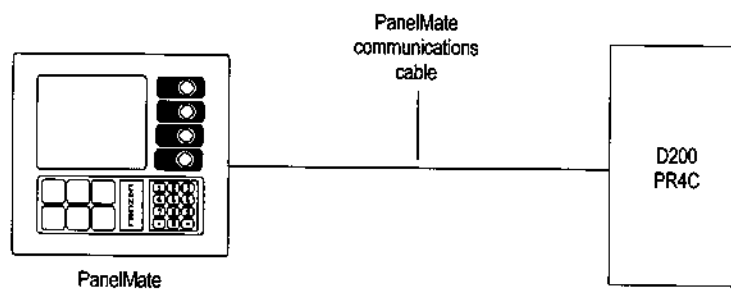


Figure 31-2 Connection to D200 PR4C Processor

## Multiple

Multiple connections to CPU20s using the computer interface terminals, or to CPU25s or CPU50s using the computer interface board (D500CIB99).

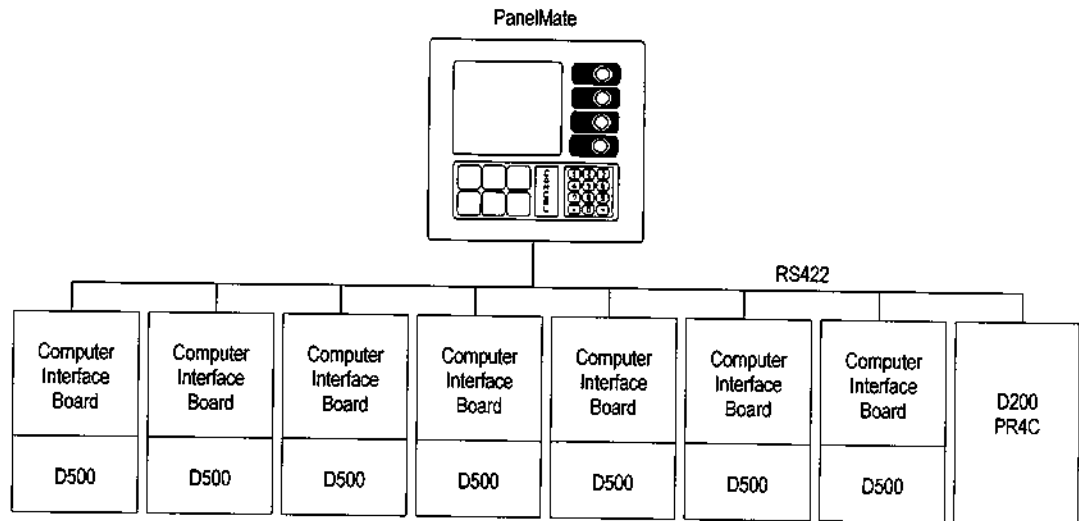


Figure 31-3 Multiple Connections

## Cabling

The communications between the PanelMate unit's serial ports and Cutler-Hammer PLCs is RS422 and, therefore, has a recommended maximum length of 4000 cable feet. You should construct a communications cable of the desired length for each connection needed. The cable is a shielded twisted pair. All PanelMate ports are female 9-pin (DB-9S), so the connectors on the cables must be male 9-pin (DB-9P).

Communications Cable for Cutler-Hammer PLC CPU20, CPU25, CPU50, D200 PR4C	
PanelMate DB-9P	Cutler-Hammer Terminal
1 TD+	3 RXA+
4 RD+	1 TXA+
5 SG	6 SG
6 TD-	5 RXB-
9 RD-	2 TXB-

Figure 31-4 RS422 Cabling

# Communications Parameters

Standard parameters for communications with Cutler-Hammer PLCs are:

- 8 data bits (fixed on Cutler-Hammer)
- 1 stop bit (fixed on Cutler-Hammer)
- NONE Parity
- 9600 Baud Rate

## CPU20

The following DIP switches are set to describe communications:

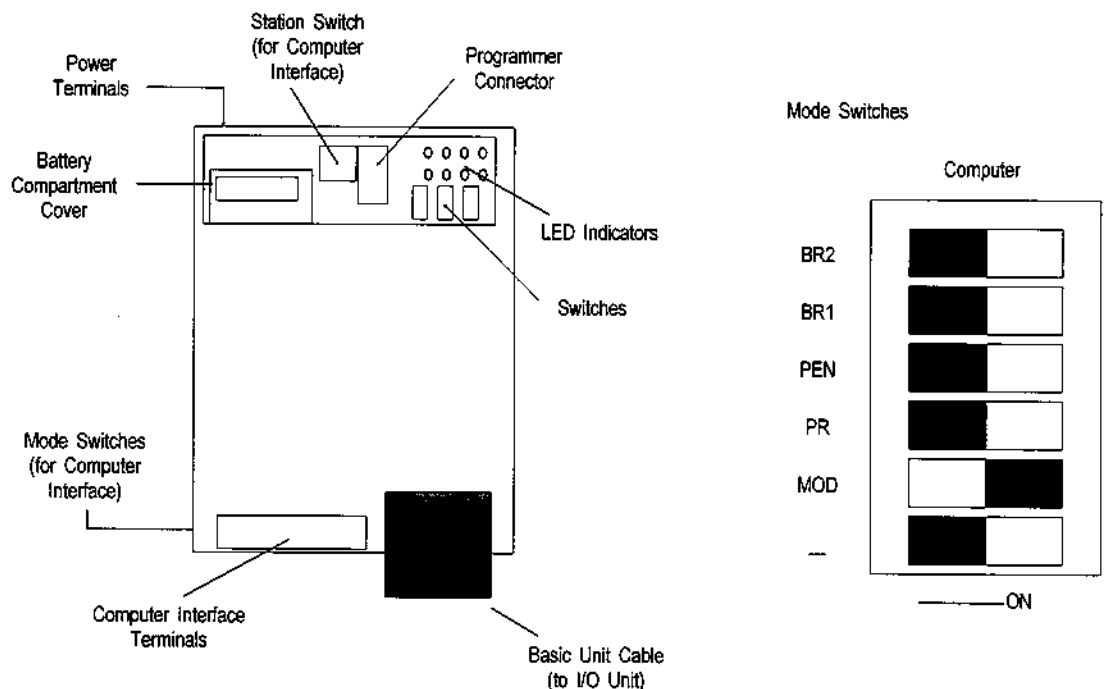


Figure 31-5 CPU20

Rate	BR2	BR1
9600	OFF	OFF
4800	OFF	ON
2400	ON	OFF
1200	ON	ON

Mode	MOD
Special	OFF
Standard	ON

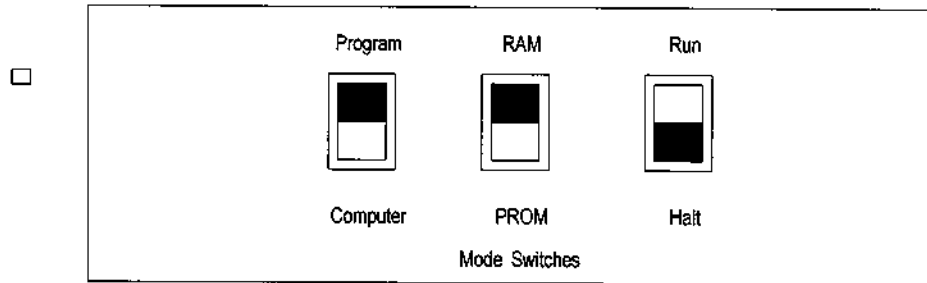
Type	PR
Odd	OFF
Even	ON

Mode	PEN
Disable	OFF
Enable	ON

Table 31-2 CPU20 Port Configurations

At the upper right of the processor, there are three two-position switches used to set its mode of operation.

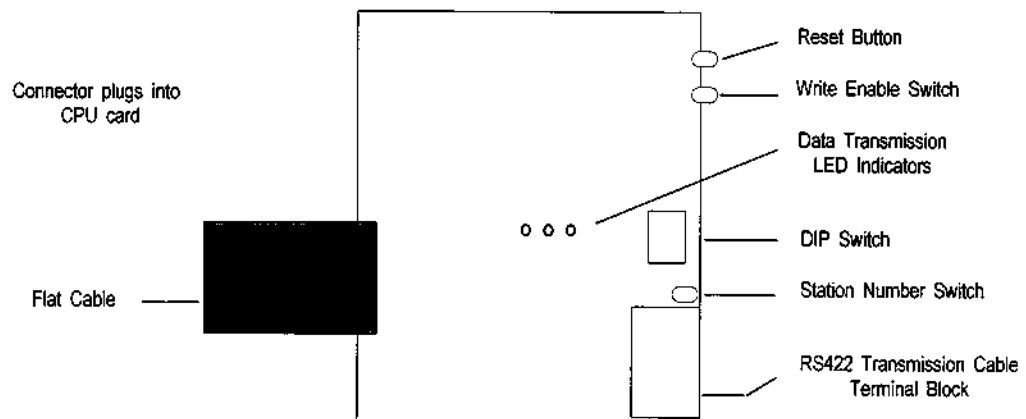


**Figure 31-6 Mode Operation Switches**

The Computer/Program slide switch must be in the Computer position and the Run/Halt slide switch must be in the Run position to enable communications with the PanelMate unit.

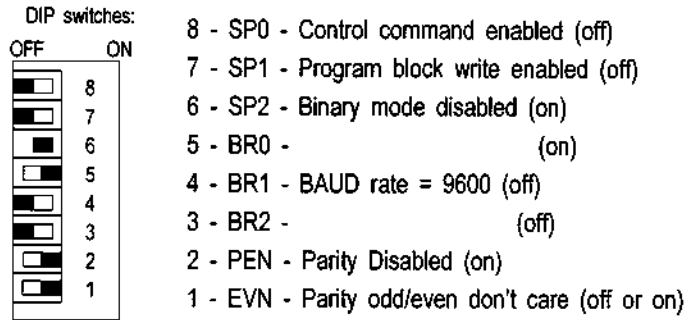
## CPU25 and CPU50

The following diagram shows the layout of the interface board for CPU25 and CPU50.



**Figure 31-7 RS422 Interface Board**

Refer to tables 31-3 and 31-4 to set communication parameters.



Baud Rate: The DIP Switch settings shown above are for 9600 Baud. If other settings are required, select the setting from the following table.

**Table 31-3 RS422 Interface Board DIP Switch Settings**

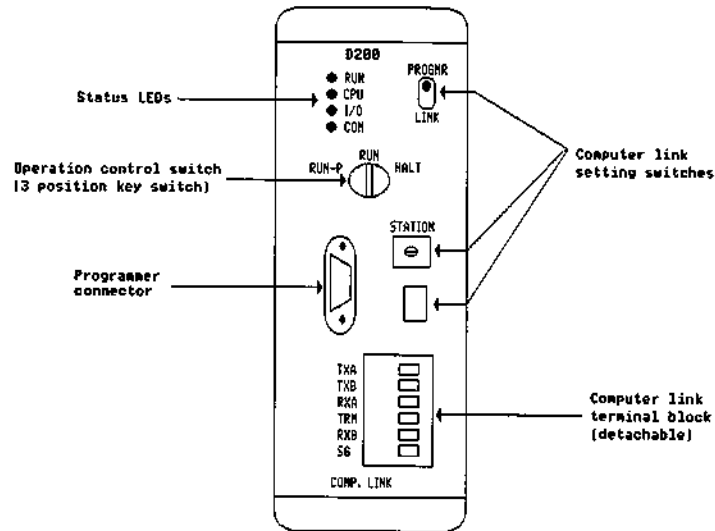
The Write Enable switch must be in the ON position.

Baud Rate	Disabled	9600	4800	2400	1200	600	300	1200
Switch								
(5) BR0	OFF	ON	OFF	ON	OFF	ON	OFF	ON
(4) BR1	OFF	OFF	ON	ON	OFF	OFF	ON	ON
(3) BR2	OFF	OFF	OFF	OFF	ON	ON	ON	ON

**Table 31-4 CPU25 and CPU50 Baud Rate Selection**

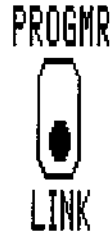
## D200 PR4C

The following DIP switches are set to define communication parameters.



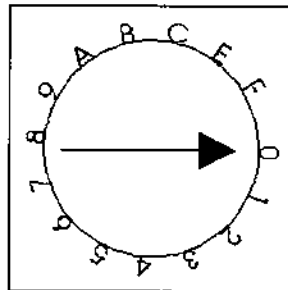
**Figure 31-8 Switch Locations**

To communicate with the PanelMate unit, the computer link setting switch should be set to link as shown in figure 31-9.



**Figure 31-9 Computer Link Setting Switch**

Use the station number rotary switch to set the station number for the computer interface mode. (0 to F)



**Figure 31-10 Station Number Rotary Switch**

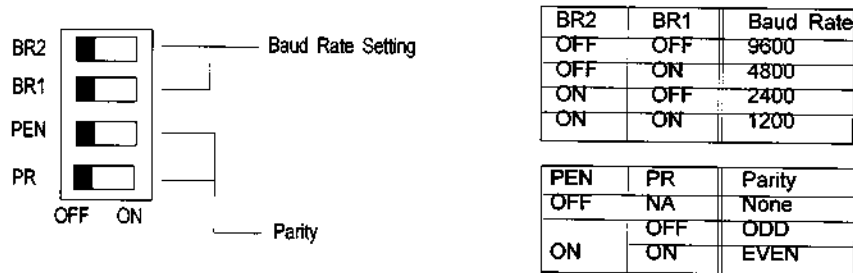


Figure 31-11 Baud Rate and Parity Switch Settings

## Cutler-Hammer Word and Bit References

The following section describes the use of Cutler-Hammer word and bit references in your configuration. The general word referencing method is:

[plcname, word#format]

The "plcnam" is the name of the designated PLC as listed in the PLC Name and Port Parameter Table. The "word" is the reference number (address) of the word or register to be read or written. The "#format" is a code which specifies the format of the data being read or written. The "plcname" and "#format" are optional.

The general bit referencing method is:

[plcname, bit]

The "plcname" is the designated PLC as listed in the PLC Name and Port Table. The "bit" is the reference number (address) of the bit, coil, or input to be written or read.

See chapter 10 for a more detailed explanation of word and bit references, including format descriptions.

## Register and Device References

### Register References

The format used for expressions is the memory type symbol (upper or lower case) and a reference number.

The following is the format for a register reference:

[mr]

m = memory type symbol (XW, YW, RW, ZW, C, T, D)

r = register value (leading 0s are not required)

**Note** In order to reference D registers greater than three digits, the D symbol must be omitted. The D symbol on register values less than four digits is optional.

## Device References

The following is the format for a device reference:

[mrb]

m = memory type symbol (X,Y,R,Z)

r = two digit register value (leading 0s are not required)

b = bit number in hex (0-F)

The supported Cutler-Hammer PLCs will allow a maximum of 32 contiguous words per read. The maximum number of unused words before another read is generated is 10.

## Examples

### Word References

<u>Reference</u>	<u>Description</u>
[YW3]	Output register 3
[XW04]	Input register 4
[D1]	Data register 1
[1500]	Data register 1500
[2]	Data register 2
[RW10]	Control relay register 10
[C29]	Counter register 29
[T17]	Timer register 17

### Bit References

[Y03F]	Output device, bit 15 of output register 3
[X110]	Input device, bit 0 of input register 11
[R147]	Control relay device, bit 7 of register 14
[Z224]	Remote link storage device, bit 4 of register 22

## **CPU20 PLC ID Number Setting**

---

The PLC ID number in the PLC Name Table must correspond to the selected station number on the CPU20. There are eight distinct ID numbers (0 through 7). Stations 8 and 9 on the rotary switch correspond to station numbers 0 and 1, respectively. To avoid confusion, do not use numbers over 7.

## **CPU25 and CPU50 PLC ID Number Settings**

---

The PLC ID number in the PLC Name Table must correspond to the selected station number on the CPU25 or CPU50. There are eight distinct ID numbers (0 through 7). Stations 8 through F on the rotary switch correspond to station numbers 0 through 7, respectively. To avoid confusion, do not use numbers over 7.

## **D200 PR4C PLC ID Number Settings**

---

The PLC ID number in the PLC Name Table must correspond to the selected station number on D200 PR4C. There are eight distinct ID numbers (0 through 7). Stations 8 through F on the rotary switch correspond to station numbers 0 through 7, respectively. To avoid confusion, do not use numbers over 7.

## **Access Permitted by Maintenance Template**

---

The Maintenance Template will access all memory locations supported by the PLC driver as defined in this chapter. When running online, you may change the PLC reference. The Maintenance Template is designed to assist you in specifying the PLC reference by scrolling through a list of mnemonics which are used to enter the PLC word reference. When online in the PLC reference change mode, the following list is available.

"X", "XW", "Y", "YW", "R", "RW", "Z", "ZW", "C", "T", "D",  
"A", "B", "E", and "F"

You must enter the correct mnemonics and numeric values and create a legal reference to change a PLC reference. Once a new reference is entered, the Maintenance Template will remain in a paused state until the control button labeled "Start Monitor" is depressed. The PanelMate Series 1000 will then parse the reference. (Parsing means checking the syntax and range of the reference to ensure that it is supported by the driver.) If correct, the template begins updating.





# Chapter 32

## General Electric PLCs

---

The GE Driver supports the Series Five, Series Six, Series Six Plus, and the Series 90 models. All models support the master/slave protocol which allows only one node to be the master (PanelMate unit). The master is the only device which can initiate communications. The Series Six and Series Six Plus models also support the peer/peer protocol which allows either device to initiate communications. The port use selections available in the PLC Name and Port Table are GE M/S (for models S5, S6, S6+, S6+WBit), GE P/P (for models S6, S6+, S6+WBit), and GE S-90 (for models 311, 331, 731, 732, 771, 772, 781, and 782). Note that there are two GE S-90 drivers. The GE-90P driver is used for point-to-point communication and the GE-90N is used for network communication.

The Series Six Plus with bit write model selection (S6+WBit) in the PLC Name and Port Table supports both the Series Six and the Series Six Plus PLCs that have a CCM2 or CCM3 card with bit write capability. In all other cases, use the driver for your specific PLC. For example, always use the S5 model selection with Series Five PLCs and the 771 model selection with the Series 90-70 model 771 PLC.

# Memory

---

The following memory types are supported by the GE Series 5, 6 and 6+ driver:

<u>Memory Type</u>	<u>Memory Address</u>
<b>16-Bit Word</b>	
R	Register
Bit	
AI	Auxiliary input (Not used in GE Series 5 PLCs)
AO	Auxiliary output (Not used in GE Series 5 PLCs)
I	Input
O	Output
Ix+yyyy	Expanded input channels
Ix-yyyy	Expanded input channels
Ox+yyyy	Expanded output channels
Ox-yyyy	Expanded output channels

Where:

x = channel numbers 1-7 and 9-F (0 and 8 are not available for Ix+yyyy and Ox+yyyy)  
yyyy = bit number 1-1024

The following memory types are supported by the GE Series 90 driver:

<u>Memory Type</u>	<u>Memory Address</u>
<b>16-Bit Word</b>	
%AI	Analog inputs
%AQ	Analog outputs
%R	Data registers
<b>Byte or Bit</b>	
%I	Discrete machine inputs
%Q	Discrete machine outputs
%M	Discrete internal coils
%T	Discrete temporary internal coils
%G	Genius global data
%S	System memory - Read Only
%SA	System memory
%SB	System memory
%SC	System memory

The following tables show the relationship between the I/O references and registers.

REAL I/O POINTS			INTERNAL DISCRETE REFERENCES	
REGISTER	I/O REFERENCE		REGISTER	I/O REFERENCE
R0001	AO0001-	AO1024	AUX	
R0065	AI0001-	A11024	AUX	
R0129	O1+0001-	O1+1024	M	
R0193	I1+0001-	I1+1024	A	
R0257	O2+0001-	O2+1024	I	
R0321	I2 + 0001-	I2 +1024	N	
R0385	O3 + 0001-	O3+1024		
R0449	I3 + 0001-	I3 +1024	I	
R0513	O4 + 0001-	O4 + 1024	O	
R0577	I4 + 0001-	I4 +1024		
R0641	O5+0001-	O5+1024	C	
R0705	I5 + 0001-	I5 +1024	H	
R0769	O6+0001-	O6+1024	A	
R0833	I6 + 0001-	I6 +1024	I	
R0897	O7+ 0001-	O7+1024	N	
R0961	I7 + 0001-	I7 +1024		
R1025	User Register			
R1089	User Register			
R1153	O9+0001-	O9+1024	A	
R1217	I9 +0001-	I9 +1024	U	
R1281	OA+0001-	OA+1024	X	
R1345	IA +0001-	IA +1024		
R1409	OB+0001-	OB+1024	I	
R1473	IB + 0001-	IB +1024	O	
R1537	OC+ 0001-	OC+1024		
R1601	IC +0001-	IC +1024	C	
R1665	OD+0001-	OD+024	H	
R1729	ID +0001-	ID +1024	A	
R1793	OE+0001-	OE+024	I	
R1857	IE +0001-	IE +1024	N	
R1921	OF+0001-	OF+024		
R1985	IF +0001-	IF +1024		
R2049	O0-0001-	O0-1024		
R2113	I0-0001-	I0-1024		
R2177	O1-0001-	O1-1024		
R2241	I1-0001-	I1-1024		
R2305	O2-0001-	O2-1024		
R2369	I2-0001-	I2-1024		
R2433	O3-0001-	O3-1024		
R2497	I3-0001-	I3-1024		
R2561	O4-0001-	O4-1024		
R2625	I4-0001-	I4-1024		
R2689	O5-0001-	O5-1024		
R2753	I5-0001-	I5-1024		
R2817	O6-0001-	O6-1024		
R2881	I6-0001-	I6-1024		
R2945	O7-0001-	O7-1024		
R3009	I7-0001-	I7-1024		
R3073	O8-0001-	O8-1024		
R3137	I8-0001-	I8-1024		
R3201	O9-0001-	O9-1024		
R3265	I9-0001-	I9-1024		
R3329	OA-0001-	OA-1024		
R3393	IA-0001-	IA-1024		
R3457	OB-0001-	OB-1024		
R3521	IB-0001-	IB-1024		
R3585	OC-0001-	OC-1024		
R3649	IC-0001-	IC-1024		
R3713	OD-0001-	OD-1024		
R3777	ID-0001-	ID-1024		
R3841	OE-0001-	OE-1024		
R3905	IE-0001-	IE-1024		
R3969	OF-0001-	OF-1024		
R4033	IF-0001-	IF-1024		

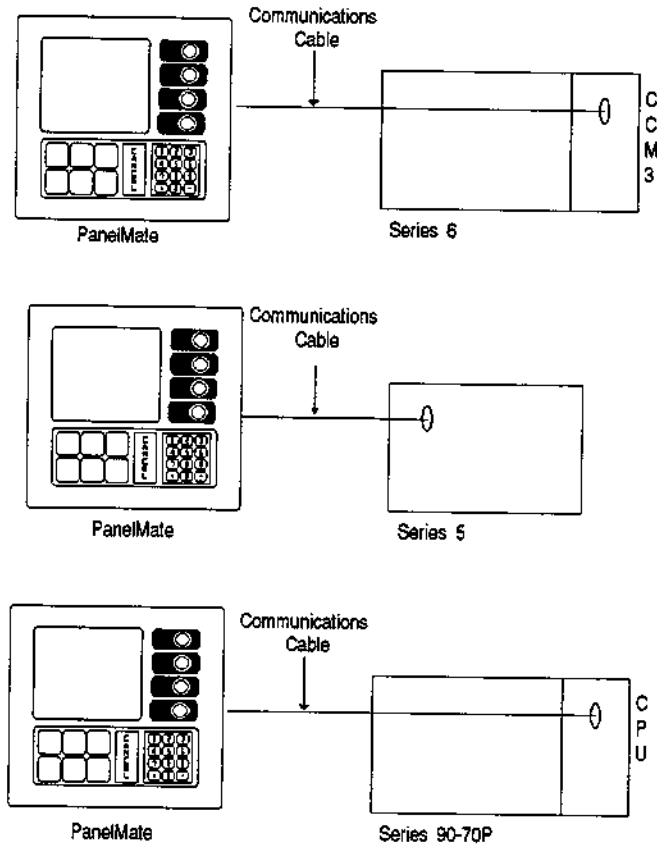
Table 32-1 I/O & Register References (Series 6 & 6+)

# Possible Configurations

The following sections describe some of the possible configurations of the PanelMate unit with General Electric PLCs.

## Direct

Direct connection between one PanelMate unit and one GE PLC. Either master/slave or peer-to-peer protocol may be used.



**Figure 32-1 Direct Connections**

Note that there are two GE S-90 drivers. For point-to-point communication, use the GE-90P driver. When communicating on a network, use the GE-90N driver.

## Multidrop

Multidrop connection between the PanelMate unit and GE PLCs. The master/slave protocol must be used for multidrop communications. The PanelMate unit is always the master and the GE PLCs are the slaves.

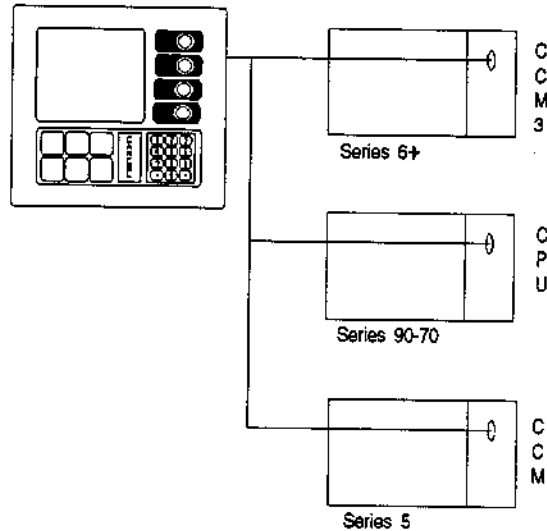
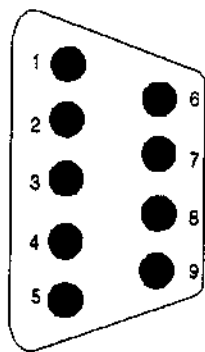


Figure 32-2 Multidrop Connection

## Cabling

Communications between the PanelMate unit and General Electric PLCs can be with either RS232C or RS422 (except for the Series 90 which is RS422 only). The maximum cable length when using RS232C is 50 feet, while the maximum cable length for RS422 is 4000 feet. All the PanelMate unit ports are female 9-pin (DB-9S), so the connectors on the cables must be male 9-pin (DB-9P).



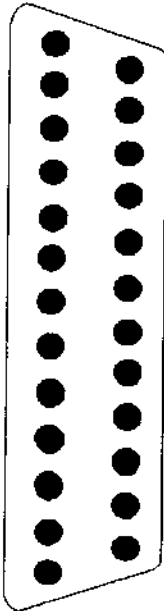
Pin	Signal
1	RS-422 Transmit Data (+) (Output)
2	RS-232 Receive Data (Input)
3	RS-232 Transmit Data (Output)
4	RS-422 Receive Data (+) (Input)
5	Signal Ground
6	RS-422 Transmit Data (-) (Output)
7	RS-232 Request to Send (Output)
8	RS-232 Clear to Send (Input)
9	RS-422 Receive Data (-) (Input)

Table 32-2 PanelMate Port Pinouts

## CCM2

The CCM2 card has two ports. One port (J1) uses a 25-pin connector, while the second port (J2) uses a 9-pin connector. The following figures show the pinouts and signals for each port.

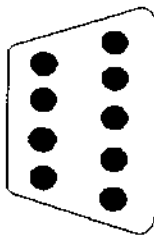
### Port J1



Pin	Signal	Pin	Signal
1	Do not connect	17	RS422 TxD (-)
2	RS232 TxD	18	RS422 TxD (+)
3	RS232 RxD	19	OIU GND
4	RS232 RTS	20	OIU +5 V (5A)
5	RS232 CTS	21	RS422 CLK in (+)
6	Do not connect	22	-12 V
7	Signal GND	23	RS422 CLK in (-)
8	Do not connect	24	RS422 CLK out (+)
9	Do not connect	25	RS422 CLK out (-)
10	Do not connect		
11	Keyout I/O		
12	+12 V		
13	RS422 RxD (+)		
14	RS422 RxD (-)		
15	Do not connect		
16	Do not connect		

Table 32-3 Port J1 Pinouts

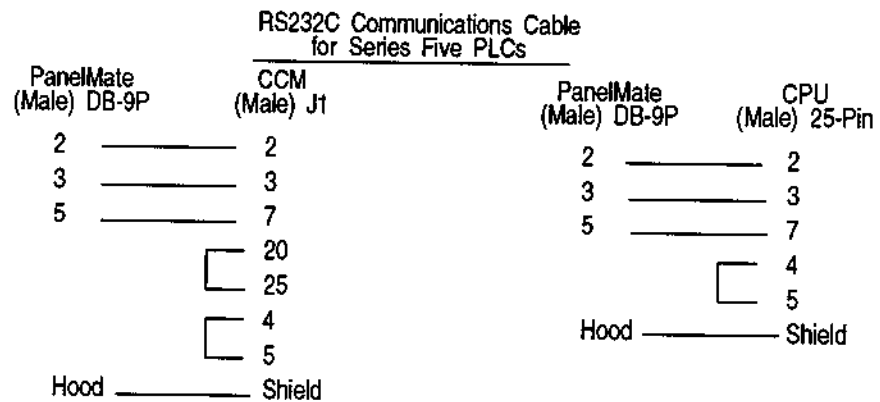
### Port J2



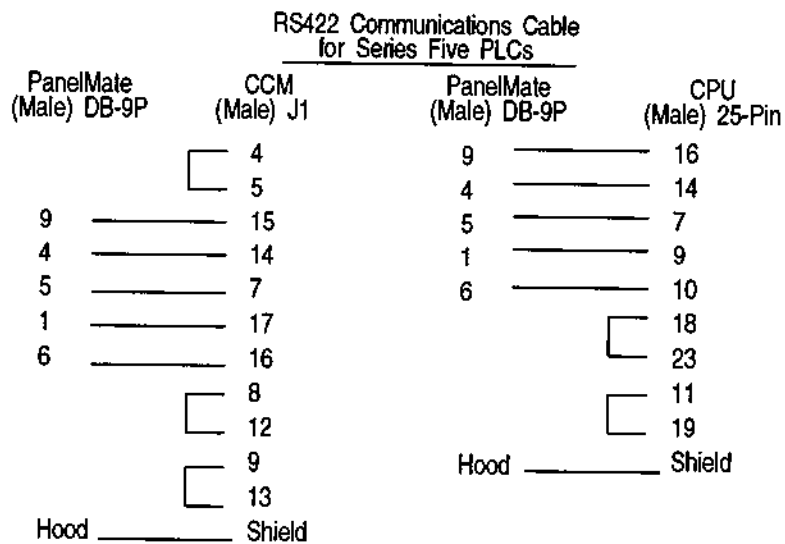
Pin	Signal
1	RS422 TxD (+)
2	RS232 TxD
3	RS232 RxD
4	RS232 RTS
5	RS232 CTS
6	RS422 TxD (-)
7	Signal GND
8	RS422 RxD (+)
9	RS422 RxD (-)

Table 32-4 Port J2 Pinouts

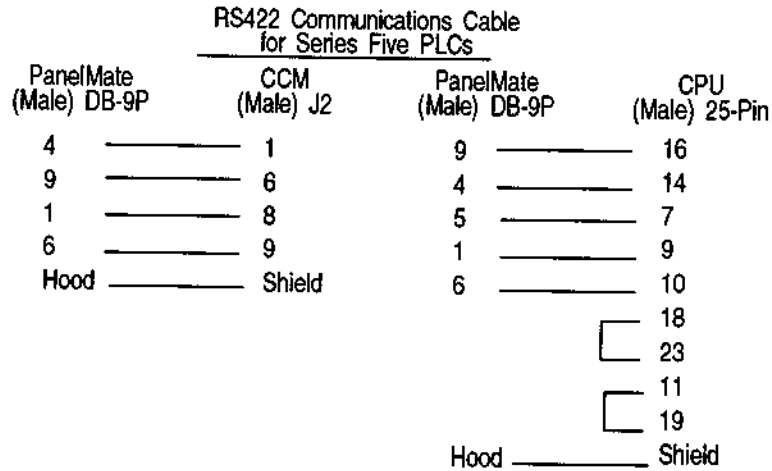
## Series Five



**Figure 32-3 RS232C Cabling for Series Five PLCs**

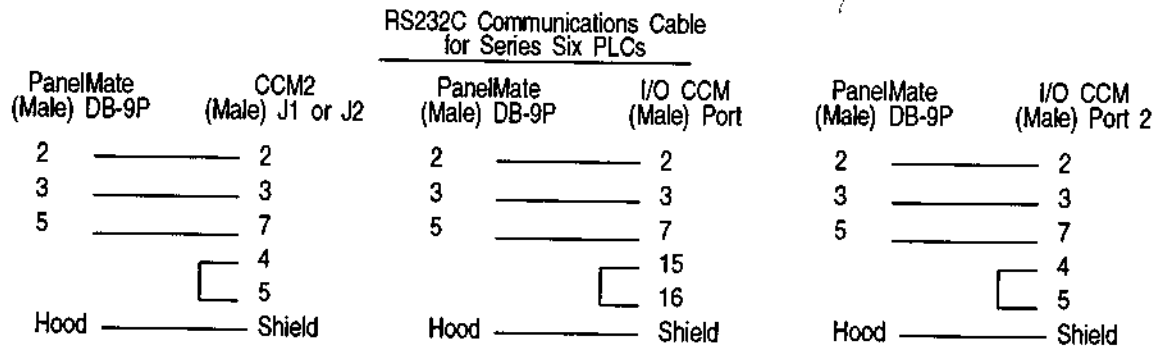


**Figure 32-4 RS422 Cabling for Series Five PLCs**

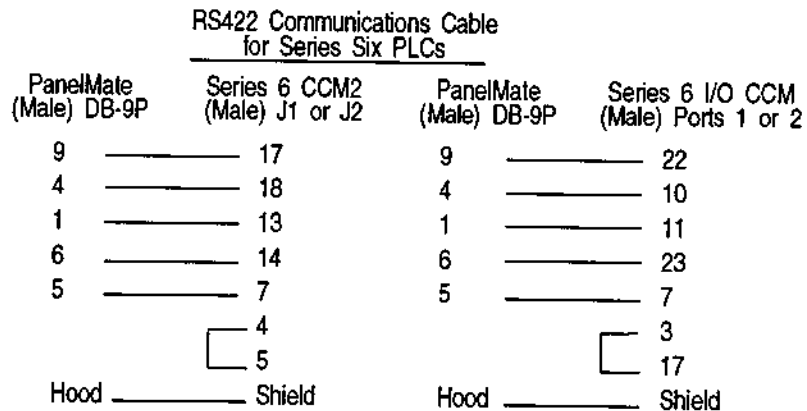


**Figure 32-5 RS422 Cabling for Series Five PLCs**

## Series Six and Six Plus



**Figure 32-6 RS232C Cabling for Series Six and Six Plus PLCs**

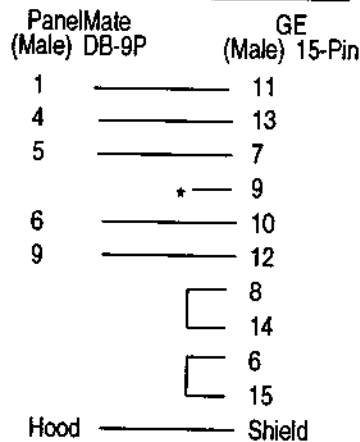


**Figure 32-7 RS422 Cabling for Series Six and Six Plus PLCs**

## Series 90

Connection to the Series 90 PLC is through the serial port located on the front of the power supply of the 90-30 PLC and on the CPU of the 90-70 PLC.

RS422 Communications Cable  
for Series 90 PLCs



- \* Termination resistance for the receive data (RD) signal needs to be connected only on units at the end of the lines. This termination is made on the Series 90 PLC products by connecting a jumper between pin 9 and pin 10 inside the 15-pin D-shell with the following exception. For Series 90-70 PLCs, catalog numbers IC697CPU731 and IC697CPU771, the termination for RD at the PLC is implemented by a jumper between pin 9 and pin 11.

Figure 32-8 RS422 Cabling for Series 90 PLCs

## Communications Parameters

Standard communication parameters for communicating with the Series Five, Series Six, Series Six Plus, and Series 90 are as follows. These parameters are given only as a starting point and may be changed to meet the demands of your application. The communication parameters are set via DIP switches on the Series Five, Series Six, and Series Six Plus PLCs and via programming software for the Series 90 PLCs. In the PLC Name and Port Table, set the PanelMate unit's communication parameters to match the settings of your PLC.

<u>Series Five</u>	<u>Series Six and Six Plus</u>	<u>Series 90</u>
8 Data bits	8 Data bits	8 Data bits
1 Stop bit	1 Stop bit	1 Stop bit
No Parity	Odd Parity	Odd Parity
19.2K Baud	9600 Baud	19.2K Baud

- Note** The minimum baud rate setting for network communication to the GE Series 90 PLC is 4800. The minimum baud rate setting for point-to-point communication to the GE Series 90 PLC is 1200.

## PLC ID

The valid PLC ID ranges for each GE PLC model are listed below. The PLC ID should match the PLC ID assigned in the PLC Name and Port Table.

<u>PLC Model</u>	<u>PLC ID Range</u>
Series Five	0 - 90
Series Six (Master/Slave)	
Series Six Plus (Master/Slave)	
Series Six (Peer/Peer)	0 - 255
Series Six Plus (Peer/Peer)	
Series 90-30	Up to 6 characters: 0-9, A-F (upper case) (e.g., 123456, ABCDEF, 1A)
Series 90-70	Up to 7 characters: ASCII character with decimal values 32-127 (e.g., 1234567, TUvwxyz, 123#)

**Note** The PLC ID in the port parameter table must match the ID in the PLC. A case discrepancy will prevent successful communications.

## Switch Settings

The PanelMate unit can use the CCM2, CCM3, or I/O CCM card for communications with a Series Six and Series Six Plus PLCs. The CCM module is needed for communications with Series Five PLCs. Each of these cards are discussed in the following sections.

### CCM

The following figure shows the port and DIP switch positions on the CCM card. This card is used with Series Five PLCs only.

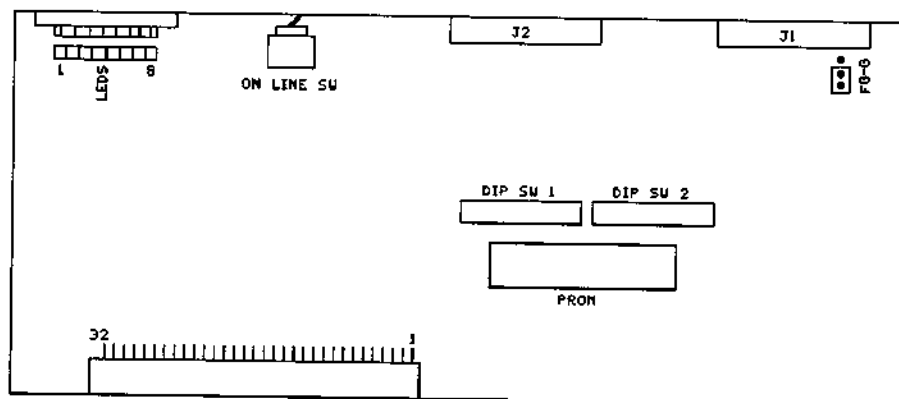


Figure 32-9 CCM Port and Switch Positions

The CCM card has two DIP switch banks, labeled DIP SW1 and DIP SW2. DIP SW1, switch 1 through switch 7, are used to set the slave station address. Switch 1 is the least significant bit. Switch 9 is used to select either master or slave.

Switch 8	Master/Slave	Switch 9
Off*	Master Slave*	On Off

\* Default

**Table 32-5 DIP Switch Bank 1**

The second DIP switch bank is used to configure the response delay time, turnaround delay, diagnostic mode, parity, and baud rate. The following tables show the possible settings for each DIP switch bank.

Baud Rate	Switch 1	Switch 2	Switch 3	Parity	Switch 4
300	On	Off	Off	Odd	On
600	Off	On	Off	None*	Off
1200	On	On	Off		
2400	Off	Off	On		
4800	On	Off	On	Self Diagnostics	Switch 5
9600*	Off	On	On	Diags On	On
19.2k	On	On	On	Diags Off	Off

Turnaround Delay	Switch 6	Delay Time	Switch 7	Switch 8	Switch 9
10 msec.	On	0*	Off	Off	Off*
No Delay*	Off	20	On	Off	
		100	Off	On	
		500	On	On	

\* Default

**Table 32-6 DIP Switch Bank 2**

## CCM2

The following figure shows the port and DIP switch positions on the CCM2 card.

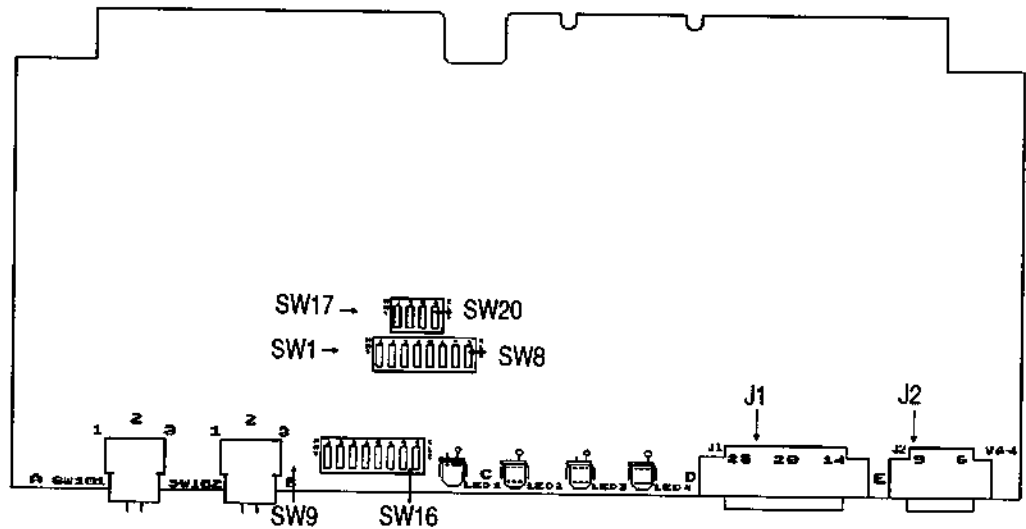


Figure 32-10 CCM2 Switch Positions

The CCM2 card has 17 DIP switches which are used for configuration of baud rate, turnaround time, protocol, and parity of the two ports, labeled "J1" and "J2". The 17 switches are divided between three switch banks and are positioned on the card as shown in figure 32-10. The switch numbers are silkscreened on the circuit board. The switch numbers given in the following tables reference the silkscreened numbers and not the switch numbers marked on each individual package.

Baud Rate	Switch 9	Switch 10	Switch 11	Turn Around Delay	Switch 15	Switch 16
300	Open	Open	Open	0 ms	Open	Open
600	Close	Open	Open	10 ms	Close	Open
1200	Open	Close	Open	500 ms	Open	Close
2400	Close	Close	Open	500 ms	Close	Close
4800	Open	Open	Close			
9600	Close	Open	Close			
19.2K	Open	Close	Close			

Protocol	Switch 12	Switch 13	Switch 14	Parity	Switch 17
Master RS232	Open	Open	Open	Enabled (odd)	Close
Master RS422	Close	Open	Open	Disabled	Open
Slave RS232	Open	Close	Open		
Slave RS422	Close	Close	Open		
Peer RS232	Open	Open	Close		
Peer RS422 w/o clk	Close	Open	Close		
Peer RS422 with clk	Open	Close	Close		
Test 3	Close	Close	Close		

Table 32-7 Port J1 Configuration

Baud Rate	Switch 1	Switch 2	Switch 3	Turn Around Delay	Switch 7	Switch 8
300	Open	Open	Open	0 ms	Open	Open
600	Close	Open	Open	10 ms	Close	Open
1200	Open	Close	Open	500 ms	Open	Close
2400	Close	Close	Open	500 ms	Close	Close
4800	Open	Open	Close			
9600	Close	Open	Close			
19.2k	Open	Close	Close			

Protocol	Switch 4	Switch 5	Switch 6
Master RS232	Open	Open	Open
Master RS422	Close	Open	Open
Slave RS232	Open	Close	Open
Slave RS422	Close	Close	Open
Peer RS232	Open	Open	Close
Peer RS422	Close	Open	Close
Test 1	Open	Close	Close
Test 2	Close	Close	Close

Miscellaneous Switch Settings	
Switch 18	Don't Care
Switch 19	Don't Care
Switch 20	Always Open

Parity	Switch 17
Enabled (odd)	Close
Disabled	Open

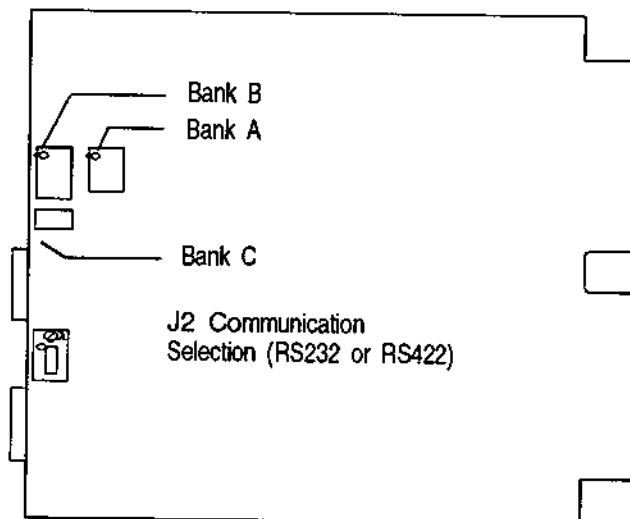
**Table 32-8 Port J2 Configuration**

## CCM3

The CCM3 card DIP switches should be configured the same as the CCM2 card described in the previous section. The placement and numbering of the DIP switches are exactly the same as the CCM2 card.

## I/O CCM

The following figure shows the port and DIP switch positions on the I/O CCM card.



**Figure 32-11 I/O CCM Switch Positions**

The I/O CCM card has three banks of DIP switches. Bank A is used to configure port one. Bank B is used to configure port two. Bank C is used to configure pins 15 and 16 for RS232D operation. The first switch position in bank C should be left in the closed state.

The following tables show the possible DIP switch settings for the I/O CCM card. The switch numbers correspond to the number on the DIP bank.

Baud Rate	Switch 1	Switch 2	Switch 3	Parity	Switch 7	Switch 8
110	Open	Open	Open	No Parity No Parity Odd Parity Even Parity	Open	Open
300	Close	Open	Open		Close	Open
600	Open	Close	Open		Open	Close
1200	Close	Close	Open		Close	Close
2400	Open	Open	Close			
4800	Close	Open	Close			
9600	Open	Close	Close			
19.2K	Close	Close	Close			

Protocol	Switch 4	Switch 5	Switch 6
CCM Master RS232/RS422	Open	Open	Open
CCM Master Current Loop	Close	Open	Open
CCM Slave RS232/RS422	Open	Close	Open
CCM Slave Current Loop	Close	Close	Open
CCM Peer RS232/RS422	Open	Open	Close
CCM Peer Current Loop	Close	Open	Close
RTU Slave RS232/RS422	Open	Close	Close
RTU Slave Current Loop	Close	Close	Close

**Table 32-9 DIP Switch Settings for Bank A**

Baud Rate	Switch 1	Switch 2	Turn-Around Delay	Switch 6	Parity	Switch 7
300	Open	Open	0 ms 500 ms	Open Close	No Parity Odd Parity	Open Close
1200	Close	Open				
9600	Open	Close				
19.2K	Close	Close				

Protocol	Switch 3	Switch 4	Switch 5
CCM Master RS232	Open	Open	Open
CCM Master RS422	Close	Open	Open
CCM Slave RS232	Open	Close	Open
CCM Slave RS422	Close	Close	Open
CCM Peer RS232	Open	Open	Close
CCM Peer RS422	Close	Open	Close
RTU Slave RS232	Open	Close	Close
RTU Slave RS422	Close	Close	Close

Module Operation	Switch 8
Operational Test	Open Close

Reset Switch	Switch 9
Enabled Reset	Open Close

**Table 32-10 DIP Switch Settings for Bank B**

Function	Switch
RS-232D Operation  Disconnects Pins 15, 16 for Port 1 RS232D Connects Pins 15, 16 for Port 1 RS232D operation (use external jumper if desired across pins 15-16)  *Factory-set default position	1  Open

**Table 32-11 DIP Switch Settings for Bank C**

**Series Five CPU**

The Series Five CPU has one four-position DIP switch bank. This DIP switch bank is used to configure the 25-pin port on the CPU and to configure the CCM address and protocol.

The following table shows the possible settings for this DIP switch:

CCM Port Communications	Switch 1	CCM Port Address	Switch 2
RS232*	On	1 (No Parity)	On
RS422	Off	Scratch Pad	Off

Baud Rate	Switch 3	Switch 4
300	Off	Off
1200	Off	On
9600*	On	Off
19.2K	On	On

\* Default

**Table 32-12 CPU DIP Switch Settings**

## General Electric Word and Bit References

The following section describes the use of General Electric word and bit references in your configuration. The general word referencing method is:

[plcname,word#format]

The "plcname" is the name of the designated PLC as listed in the PLC Name and Port Table. The "word" is the reference number (address) of the word or register to be read or written. The "#format" is a code which specifies the format of the data being read or written. The "plcname" and "#format" are optional.

The general bit referencing method is:

[plcname,bit]

The "plcname" is the designated PLC as listed in the PLC Name and Port Table. The "bit" is the reference number (address) of the bit, coil, or input to be written or read.

See chapter 10 for a more detailed explanation of word and bit references, including format descriptions.

## GE Series Five PLC Word and Bit References

---

Series Five PLCs use decimal word addresses. The PanelMate unit format default is U16. Inputs and outputs use bit references.

The following list contains the memory types and ranges supported by the Series Five driver:

I0001	to	I1024
O0001	to	O1024
I1+0001	to	I1+1024
O1+0001	to	O1+1024
O1-0001	to	O1-1024
O2-0001	to	O2-1024
I1-0001	to	I1-512
I2+0001	to	I2+1024
O2+0001	to	O2+1024
R00001	to	R16384

**Figure 32-12 Memory Types and Ranges**

All of the references in Table 32-12 are bit references, except for registers R00001 through R16384, which are word references.

The following is the format for a register reference.

[rr]  
rr                    PLC reference number of the register.

The following is the format for a bit reference:

[xi]  
x                    PLC memory type (O or I).  
i                    PLC reference number of the input or output.

The following is the format for a register bit reference (Read Only):

[rr bb]  
rr                    PLC reference number of the register.  
bb                    PLC reference number of the bit position. The bit positions are numbered from 1 to 16, least significant to most significant, respectively.

**Note** The register number must be followed by a space.

The PanelMate unit can reference more than one PLC word with a single read. The Series Five PLC can read a maximum of forty words per read. The maximum number of unused PLC words per read is ten. Once ten unused PLC words are encountered, the PanelMate unit will generate another read.

**Note** The following bit writes are used by the CPU:

Internal status bits I1-XXX (read only)  
Output status bits O2-1000 through O2-1024

## Series Six Word and Bit References

GE Series Six PLCs use decimal word addresses. The PanelMate unit format default is U16.

The following list contains the memory types supported by the Series Six driver:

AI	Auxiliary Input (Bit Reference)
AO	Auxiliary Output (Bit Reference)
I	Input (Bit Reference)
O	Output (Bit Reference)
R	Register (Word Reference)

The following is the format for a register reference.

[rr]  
rr                    PLC reference number of the register.

The following is the format for a bit reference:

[xi]  
x                    PLC memory type (O or I).  
i                    PLC reference number of the input or output.

The following is the format for a register bit reference (Read Only):

[rr bb]  
rr                    PLC reference number of the register.  
bb                    PLC reference number of the bit position. The bit positions are numbered from 1 to 16, least significant to most significant, respectively.

**Note**    The register number must be followed by a space.

Note that General Electric Series Six Family PLCs store double precision numbers with the first (low) register holding the least significant word and the next consecutive (high) register holding the most significant word. The PanelMate unit, however, interprets the first register as the most significant word and the next consecutive register as the least significant word. For example, if the value 1 is stored in register 624 and the value 0 is stored in register 625, General Electric would interpret the stored value as 1, while the PanelMate unit would display the value as 65536. To read a double precision number correctly, multiply the low byte by 65536 and add this value to the high byte.

### Bit Writes Without Ladder Logic

The GE Fanuc communication protocol for Series Six, for the latest CCM2 and CCM3 cards, will allow the PanelMate unit to directly alter the state of a single bit without the use of ladder logic. The part numbers for the cards which allow single bit writes are listed below:

CCM2	IC600CB536-1
CCM3	IC600CB537-M

The part number should be labeled in the lower lefthand corner of the board. If either of these cards are installed, then select "S6+WBit", even for Series Six PLCs, for the model name in the PLC Name and Port Editor; otherwise, select "S6". If the board number is IC600CB516 or IC600CB517, an upgrade kit is available from General Electric to allow single bit writes without using ladder logic.

### Bit Writes With Ladder Logic

CCM cards, other than those mentioned in the previous section, will not permit an external intelligent device to directly alter the state of a single bit (input, output, etc.) without overwriting the entire word in which that bit exists. As a result, the PanelMate unit will write a value to a designated word in the GE PLCs specifying which bit should be set or cleared. A section of each PLC program is necessary to interpret this value in order to change the appropriate bit.

Within the PLC Name Table, the PLC ID# is defined using the following format:

ID#-Rreg# (8 characters maximum)

ID#	PLC ID#
R	optional "R"
reg#	Register value used to receive bit set/clear information

**Note** If no register value is entered, the default is 255.

The value that the PanelMate unit writes to the PLC in order to specify what bits to write, always contains the number (address) of the bit to be changed. This value is represented as a positive or negative number, depending on whether the bit is to be set or cleared, respectively. The value sent to the PLC is sent using the normal Series Six word/block write instruction. The value is described below:

15000 < value	=	AIx where x = value - 15000
10000 < value <= 15000	=	Ix where x = value - 10000
5000 < value <= 10000	=	AOx where x = value - 5000
0 < value <= 5000	=	Ox where x = value

The following ladder logic rungs may be added to a GE PLC program for the purpose of setting and clearing individual bits as dictated by the instructions the PanelMate unit writes to the unit's instruction word (word 255) in GE PLCs.

GE Series 6: Program to Interpret Bit Controls

If Bit Address in Reg 255

```

CONST          R0256    R0255    R0256                                O1023
+[ A    MOVE    B ]+[ A :    B    ]-----+-----+-----+-----+-( )--+
|+00000

```

|

+

|Then set or clear bit

```

IO1023  CONST          R0256          CONST  R0256
+--[ ]-[ A MOVE    B ]+[DO {SUB    N    REPS]+          ( )
|          +00001          001

```

|

+

|Reset Reg 255

```

IO1023  CONST          R0255
+--[ ]-[ A MOVE    B ]+          ( )
|          +00000

```

|

+ELSE continue with other processing

|

+{ENDSW}+

|

```

IR0255          R0254
+[ A    MOVE    B ]+          ( )
|

```





```

|
IO1020    R0255  CONST  R0254
+--+ [-+ [ A  SUBX B    = C ]+          ( )
|
|          +05000
|
|If address>0 then set bit
IO1020    O1024  R0254          AO0001  CONST
+--+ [-+--+][+--+ [ BIT    SET    MATRIX  LEN]+          ( )
|
|          064
|
|Else clear bit
|
IO1020    O1024  R0254          AO0001  CONST
+--+ [-+ ] [-+ [ BIT    CLEAR  MATRIX  LEN]+          ( )
|
|          064
|
|Outputs
+
IO1022    O1021  O1020  R0255          R0253
+--+ / [----] / [----] / [--- [ A    Move    B]-
|
|
|Else if address>0 then set bit
|
IO1022    O1021  O1020  O1024  R0253          O0001  CONST
+--+ / [+--+ ] / [+--+ ] / [+--+ ] / [+--+ [ BIT    SET    MATRIX  LEN]+          ( )
|
|          064
|
|Else clear bit
+
|
IO1022    O1021  I1020  I1024  R0253          O0001  CONST
+--+ / [+--+ ] / [+--+ ] / [+--+ ] [-+ [ BIT    CLEAR  MATRIX  LEN]+          ( )
|
|          064
+
|
+ [ RETURN ] +
+
|
+[ENDSW]+ Note:   Bit reference is sent to register 255.  If bit reference
|                  is negative then bit is to be cleared, otherwise bit is
|                  to be set
+

```

|  
| Registers - 253, 254, 255, and 256 are used by the program.  
+{ENDSW}+

| Output points 1020, 1021, 1022, 1023, and 1024 are used by the program.  
|

## **GE Series Six Plus Word and Bit References**

GE Series Six Plus PLCs use decimal word addresses. The PanelMate unit format default is U16.

For Series Six Plus PLCs, the PanelMate unit permits access to all memory addresses, up through the largest 5-digit address available (the PanelMate unit can actually read addresses up through a maximum of 99999). All registers in the Series Six Plus may be accessed by the PanelMate unit directly. Series Six Plus units feature extended I/O channels with addresses grouped in blocks of 1024, using prefixes such as I2+.

The following list contains the memory types supported by the Series Six Plus driver.

AI	Auxiliary Input (Bit Reference)
AO	Auxiliary Output (Bit Reference)
I	Input (Bit Reference)
O	Output (Bit Reference)
R	Register (Word Reference)
Ix + yyyy	Expanded Input Channels
Ox + yyyy	Expanded Output Channels

where x = channel numbers 1 - 7 and 9 - F (0 and 8 not available )  
yyyy = bit number 1 - 1024

### **Bit Writes Without Ladder Logic**

The GE Fanuc communication protocol for Series Six Plus for the latest CCM2 and CCM3 cards will allow the PanelMate unit to directly alter the state of a single bit without the use of ladder logic. The part numbers for the cards which allow single bit writes are listed below:

CCM2 IC600CB536-1  
CCM3 IC600CB537-M

The part number should be labeled in the lower lefthand corner of the board. If either of these cards are installed, then select "S6+WBit" for the model name in the PLC Name and Port Editor; otherwise, select "S6+". If the board number is IC600CB516 or IC600CB517, an upgrade kit is available from General Electric to allow single bit writes without using ladder logic.

## Bit Writes With Ladder Logic

CCM cards, other than those mentioned in the previous section, will not permit an external intelligent device to directly alter the state of a single bit (input, output, etc.) without overwriting the entire word in which that bit exists. As a result, the PanelMate unit will write a value to a designated word in the GE PLCs, specifying which bit should be set or cleared. A section of each PLC program is necessary to interpret this value in order to change the appropriate bit.

Within the PLC Name Table, the PLC ID# is defined using the following format:

ID#-Rreg# (8 characters maximum)

ID#	PLC ID#
R	optional "R"
reg#	Register value used to receive bit set/clear information

**Note** If no register value is entered, the default is 255.

The value that the PanelMate unit writes to the PLC in order to specify which bits to write, contains the register and number of the bit to be changed. This value is represented as a positive or negative number, depending on whether the bit is to be set or cleared, respectively. The PLC word containing the value is controlled by the PanelMate unit, using normal Series Six Plus word/block write instructions.

The two byte value sent by the PanelMate unit is represented as shown in the following figure:

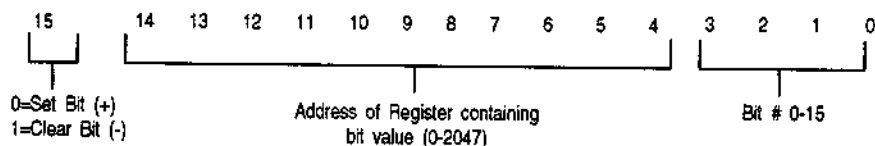


Figure 32-13 Bit Reference Format

**Note** It is not possible to write to references lx-yyyy or Ox-yyyy.

Note that GE register values range from 1 - 2048, and bits are numbered 1-16 per register. The PanelMate unit sends a register value from 0 - 2047, and a bit value from 0 - 15. When the PanelMate unit sends a bit value of 0, it is interpreted as the sixteenth bit of the designated register value, and when it is 1 - 15, it is the specified bit of the designated register value +1.

## Examples

PanelMate Reference = OF + 0001

Value sent to GE = 0111100000000001 (reg. = 1920, bit = 1)

Interpretation = Set bit 1 of register 1921

PanelMate Reference OE + 1024

Value sent to GE = 0111100000000000 (reg. = 1920, bit = 0)

Interpretation = Set bit 16 of register 1920

PanelMate Reference = O1

Value sent to GE = 0100000000000001 (reg. = 1024, bit = 1)

Interpretation = Set Output value bit 1

PanelMate Reference AO1

Value sent to GE = 0000000000000011 (reg. = 0, bit = 3)

Interpretation = Set Auxiliary Output value 3 (bit 3 of register 1)

PanelMate Reference = AO1

Value sent to GE = 1111111111111101 (reg. = 0, bit 3)

Interpretation = Clear Auxiliary Output value 3 (bit 3 of register 1)

In the last example, the value is negative so the twos complement is calculated before interpreting a register and bit value. I/O bit values (Ixxxx, Oxxxx) are designated as being in registers 1024 - 1151, but the values in the registers are not affected since the I/O bit values are stored in a separate location. I/O values I1024 and O1024 are not available for setting and clearing unless logic is added to the PLC program to check the bit value, in addition to the register range. In the PLC program supplied, Output register values are 1024 - 1087, and Input register values are 1088 - 1151. Output 1024 would be designated as register 1088, bit 0, and Input 1024 would be designated as register 1152, bit 0.

The following ladder logic rungs may be added to a Series Six Plus PLC program for the purpose of setting and clearing individual bits as dictated by the instructions the PanelMate unit writes to the bit write register (default word 255) in GE PLCs.

```

*****
|
|
|
|
|
|
|
|[NO OP]          ( )
|
|
|
| <<RUNG 390>>
|
|
|
*****
|

```

**IGE Series Six Plus:**

Program section to implement bit set and clear operations for the PanelMate unit's pushbuttons when the PanelMate unit is used with the Series Six Plus advanced I/O.

The registers used are R0620 through R0632, and the outputs used are AO977 through AO985. Any other data space could be used by modifying this section of program.

The PanelMate unit instructs the GE PLCs to set and clear bits by writing coded values to a register called the "Bit Write Register" (BWR). The BWR is user-selectable during development using the PLC Name and Port Editor of the PanelMate unit. A register number may be entered following a PLC ID# and a "-" character in the Logical Device Unit, PLC ID# field. If no register number is explicitly designated by the user, the BWR used defaults to R0255 (default setting).

In the following program, the BWR is R0621. Whenever R0621 is nonzero, the PanelMate unit has written a "Bit Write Code" (BWC) to the BWR, indicating a bit to set or clear. AO977 becomes energized otherwise.

	Bit	Bit	Bit		Do not
	Write	Write	Write		Set or
	Memory	Registr	Memory		Clear
IConst	R0622	R0621	R0622		AO977

```

|[A MOVE B ]-[ A B ]------( )
|+00000
|
| <<RUNG 391>>
|
*****
|

```

If there is a BWC in BWR, call the subroutine to set/clear bits.

```
|  
|  
|Do not  
|Set or  
|Clear  
|  
|AO0977 Const R0620 Const R0620  
+)]/[--[ A MOVE B ]] DO SUB N REPS ]- ( )  
| 390 +00001 001  
|  
| <<RUNG 392>>  
|  
|
```

\*\*\*\*\*

```
|  
|Clear the BWR, if there is a BWC (Note - for purposes of debugging, it is most convenient to temporarily remove this rung.)  
|
```

```
|  
|  
|Debug Do not Bit  
|Rung Set or Write  
|Remover Clear Register  
|  
|AO0985 AO0977 Const R0621  
+)] [----]/[----[ A MOVE B ]- ( )  
| 390 +00000  
|  
| <<RUNG 393>>  
|
```

\*\*\*\*\*

```
|  
|Else continue with other processing  
|  
|[ENDSW]-  
| <<RUNG 394>>
```

\*\*\*\*\*

|  
|Subroutine to set/clear bits. Copy BWC (R0621) to R0622

|  
|Bit                    Bit  
|Write                 Write  
|Register             Memory

|R0621                 R0622  
|[ A        MOVE        B ]-                                   ( )

| <<RUNG 395>>

\*\*\*\*\*

|  
|Test BWC to see if it is a negative number and energize AO0978 if it is  
|(high bit set). Note that whenever the BWC is positive, a bit is to be  
|set, however, if the BWC is negative, a bit is cleared.

|  
|                                    Bit  
|                                    Write  
|                                    Memory  
|  
|                    Const    R0622    Const                                    AO0978  
|[SHIFT LEFT        N        MATRIX    LEN ]------( )  
|                    000001                    001

| <<RUNG 396>>

\*\*\*\*\*

|  
| Copy BWC (R0621) to R0622 again

|  
|           Bit                    Bit  
|           Write                  Write  
|           Register               Memory  
|  
|           R0621                  R0622  
+|        A        MOVE        B ]-                   ( )

| <<RUNG 397>>

\*\*\*\*\*

|  
| Derive the absolute value of the BWC in R0622. If the BWC is negative,  
| take the two's complement of the value. (Invert all bits and add one.)

|  
|           Bit        Bit  
|           Write     Write  
|           Memory   Memory  
|  
IAO0978 R0622 R0622 Const  
+>] [---[    A  INV  B        LEN]-                   ( )  
|    395                    001

| <<RUNG 398>>

|           Bit                    Bit  
|           Write                  Write  
|           Memory                 Memory

+AO0978 R0622 Const R0622  
|-----] [---[    A  ADDX        B  =    C ]-                   ( )  
|    395                    +00001

| <<RUNG 399>>

\*\*\*\*\*

|

|Clear R0623

|

| # of Bit  
| to be  
| set

|

|Const R0623

|+ [ A MOVE B ]- ( )

|+00000

|

| <<RUNG 400>>

|

\*\*\*\*\*

|

!The upper 12 bits of the BWC contain the address of the register  
!containing the bit to be set or cleared. Shift these bits from  
!R0622 to R0623, and then save them in R0624.

|

| Bit  
| Write  
| Memory

|

| Const R0622 Const  
|+ [ SHIFT LEFT N MATRIX LEN ]- ( )

| 00012 002

|

| <<RUNG 401>>

|

\*\*\*\*\*

|

!Move the Register Address to R0624

|

```

I# of Bit   Registr
Ito be      Address
Iset        of Bit
|
IR0623      R0624
+{ A      MOVE      B }-      ( )
|
|
| <<RUNG 402>>
|
.....

|Clear R0623
|
|          # of Bit
|          to be
|          Set
|
| Const      R0623
+{ A      MOVE      B }-      ( )
| +00000
|
| <<RUNG 403>>
|
.....

|
|The lower 4 bits of the BWC (still in R0622) contain the number of the
|bit to be set or cleared. Shift these bits from R0622 to R0623, and
|allow them to remain in R0623.
|
|          Bit
|          Write
|          Memory
|
|          Const      R0622      Const
+{ SHIFT LEFT      N      MATRIX      LEN ] -      ( )
|          00004          002
|
| <<RUNG 404>>

```

```

|
| Const          R0631
|[ A    MOVE    B ]-          ( )
| +00000
|
| <<RUNG 405>>
|

```

```

| Const          R0632
|[ A    MOVE    B ]-          ( )
| +00000
|
| <<RUNG 406>>
|

```

|# of Bit  
|to be  
|set

```

|IR0623          R0632
|[ A    MOVE    B ]-          ( )
|
| <<RUNG 407>>
|
|
|.....
|

```

|The following checks register R0623 for zero. If the 4 bits of the BWC  
|(in R0623) is zero, this indicates that the 16th bit needs to be cleared,  
|therefore 16 must be added to R0623. The following rungs will accomplish  
|this function.

```

|
|IR0632          R0631          AO0982
|[ A :    B ]----- ( )
|
|
| <<RUNG 408>>
|
|.....
|

```

```

|                                     # of Bit
|                                     to be
|                                     set
|
|AO0982  Const          R0623          AO0981
|←--] [---] A      MOVE      B ]----- ( )
| 407 +00016
|
| <<RUNG 409>>
|

```

.....

If the register address in R0624 is <= 1067 and R0624 > = 1024, then the bit to be set or cleared is a real output. AO0979 becomes energized and IR0625 and R0626 are ignored. Note that the register address is actually register address -1.

```

|Register          Register  NotReal          Bit is
|Address           Address   Address       Real
|of Bit           of Bit    Memory        Output
|
|IR0624  Const  R0625  Const  R0624  R0626          AO0979
|+[ A SUBX B =  C ]-[ A SUBX B =  C ]----- ( )
|      +01087      +01024
|
| <<RUNG 410>>
|

```

.....

If BWC is for a real output, subtract 1024 from the register address, multiply by 16, and add the bit number to get the address of the output to set or clear (00001 through 01024)

```

|
|Bit is      Register
|Real       Address
|Output     of Bit
|
|AO0979     R0624           R0627   R0627   Const   R0628
+----] [----] A      MOVE      B ][      A SUBX   B =    C ]-      ( )
| 409                                           +01024
|
| <<RUNG 411>>
|
|

```

```

|Bit is
|Real
|Output
|
|AO0979     R0628   Const   R0629
+----] [----] A  MPY  B =    C ]-      ( )
| 409           +00016
|
| <<RUNG 412>>
|

```

```

|Bit is                                     # of Bit   Not Real
|Real                                     to be      I/O Reg
|Output                                  Set        Address
|AO0979                                R0629      R0623   R0630
|----] [----] A                        ADDX      B =    C ]-
| 409
| <<RUNG 413>>
|

```

\*\*\*\*\*

```

|
|Set the output when the BWC is positive
|

```

```

|Bit is          Not Real
|Real           I/O Reg
|Output         Address
|
IAO0979 AO0978 R0630          O0001  Const
+----] [-----] / [-----] [ BIT      SET   MATRIX   LEN]-          ( )
|  409      395                315      064
|
| <<RUNG 414>>
|

```

.....

```

|
|Clear the output when the BWC is negative.
|
|Bit is          Not Real
|Real           I/O Reg
|Output         Address
|
IAO0979 AO0978 R0630          O0001  Const
+----] [-----] [-----] [ BIT      CLEAR MATRIX   LEN]-          ( )
|  409      395                315      064
|
|
| <<RUNG 415>>
|

```

.....

If the register address in R0624 is <= 1151 and R0624 >= 1088, then the bit to be set or cleared is a real input. IAO0980 becomes energized and R0625 and R0626 are ignored.

```

|
|Register          Register  Not Real          Bit is
|Address          Address   Address          Real
|of Bit          of Bit    Memory          Input
|
|R0624  Const  R0625  Const  R0624  R0626          AO0980
|[ A SUBX B      C ] [  A SUBX  B  =  C ]----- ( )
|      +01151      +01088
| <<RUNG 416>>

```

|  
 If the BWC is for a real input, subtract 1088 from the register address,  
 multiply by 16, and add the bit number to get the address of the input  
 to set or clear. (I0001 through I1024)

```
|
|Bit is      Register
|Real       Address
|Input      of Bit
|
|AO0980  R0624          R0627  R0627  Const  R0628
|+---] [----] A      MOVE    B  ]-[  A SUBX B  =  C  ]-      ( )
| 415                                     +01088
```

```
|
| <<RUNG 417>>
```

```
|
|Bit is
|Real
|Input
|
|AO0980  R0628  Const  R0629
|+---] [----] A MPY    B  =  C  ]-      ( )
| 415          +00016
```

```
|
| <<RUNG 418>>
```

```
|
|Bit is          # of Bit  Not Real
|Real           to be     I/O Reg
|Input          set       Address
```

```
|
|AO0980  R0629  R0623  R0630
|+---] [----] A ADDX  B  =  C  ]-      ( )
| 415
```

```
|
| <<RUNG 419>>
```

```
|
|
|*****
```

```

|
|Set the input when the BWC is positive
|
|Bit is          Not Real
|Real            I/O Reg
|Input           Address
|
|AO0980  AO0978  R0630          I0001  Const
|--] [-----] / [-----] [ BIT   SET   MATRIX   LEN]-      ( )
|  415      395                                064
|
| <<RUNG 420>>
|
|*****
|
|
|Clear the input when the BWC is negative
|
|Bit is          Not Real
|Real            I/O Reg
|Input           Address
|
|AO0980  AO0978  R0630          I0001  Const
|--] [-----] [-----] [ BIT   CLEAR  MATRIX   LEN]-      ( )
|  415      395                                064
|
| <<RUNG 421>>
|
|Bit is  Bit is      Register      Not Real
|Real    Real        Address        I/O Reg
|Output  Input       of Bit         Address
|
|AO0979  AO0980  AO0981  R0624          Const  R0630
+---] / [-----] / [-----] / [-----] [ A  ADDX   B  =  C ]-      ( )
|  409      415      408                                +00001
|
| <<RUNG 422>>
|

```

|  
 .....

|  
 If the BWC is not a real input, output or if the "Adding 16 to Register"  
 (See Rung 407 - 408) function was not implemented, add one to the  
 register address to get a register range of R00001 through R02048 and  
 store in register R0630.

|  
 If the "Adding 16 to Register" function was implemented, then do not add  
 1 (one) to the register, instead, store the register address in R0630.

Bit is	Bit is	Not Real	Registr	Not Real
Real	Real	I/O Reg	Address	I/O Reg
Output	Input	Address	of Bit	Address

AO0979	AO0980	AO0981	Const	R0630	R0624	R0630	
+---	/ -----	/ -----	---	A MOVE B	A MOVE B		( )
409	415	408	+00000				

|  
 | <<RUNG 423>>  
 |  
 |

.....

|  
 Store the value in the register designated by the address in R0630 in  
 IR0626

Bit is	Bit is	Not Real
Real	Real	Address
Output	Input	Memory

AO0979	AO0980	IR0630	R0626	Const
+---	/ -----	/ -----	A MOVE TBL EXT B	LEN
409	415			001

|  
 | RUNG 424>>  
 |

```

.....
|
|
|When the BWC is positive, set the bit in the value copied in R0626.
|
|
|Bit is      Bit is      # of Bit      Not Real
|Real       Real        to be          Address
|Output     Input       set            Memory
|
|AO0979   AO0980   AO0978   R0623           R0626   Const
|+---+ / [-----] / [-----] / [-----] [ BIT   SET   MATRIX   LEN]-      ( )
|  409     415     395                               001
|
| <<RUNG 425>>
|
|
|

```

```

.....
|
|
|When the BWC is negative, clear the bit in the value copied in R0626.
|
|
|Bit is      Bit is      # of Bit      Not Real
|Real       Real        to be          Address
|Output     Input       set            Memory
|
|AO0979   AO0980   AO0978   R0623           R0626   Const
|+---+ / [-----] / [-----] [-----] [ BIT   CLEAR  MATRIX   LEN]-      ( )
|  409     415     395                               001
|
| <<RUNG 426>>
|
|
|

```



## GE Series 90 PLC Word and Bit References

Series 90 PLCs use decimal word addresses. The PanelMate unit format default is S16, where the values can range from -32768 to 32767. 32-bit formats are not allowed for the byte memory type (i.e., S32, U32, BCD6, BCD8, BIN6, or BIN8). See the Word and Bit References section in Chapter 10 for valid word formats.

The following are the memory ranges for the Series 90-30 and 90-70 models.

	<u>311</u>	<u>331</u>	<u>731 732</u>	<u>771 772</u>	<u>781 782</u>
%AI (Read/Write)	1-64	1-128	1-8192	1-8192	1-8192
%AQ (Read/Write)	1-32	1-64	1-8192	1-8192	1-8192
%R (Read/Write)	1-512	1-2048	1-16384	1-16384	1-16384
%I (Read/Write)	1-512	1-512	1-512	1-2048	1-12288
%Q (Read/Write)	1-512	1-512	1-512	1-2048	1-12288
%M (Read/Write)	1-1024	1-1024	1-2048	1-4096	1-12288
%T (Read/Write)	1-256	1-256	1-256	1-256	1-256
%G (Read/Write)	1-1280	1-1280	1-1280	1-7680	1-7680
%S (Read Only)	1-32	1-32	1-128	1-128	1-128
%SA (Read/Write)	1-32	1-32	1-128	1-128	1-128
%SB (Read/Write)	1-32	1-32	1-128	1-128	1-128
%SC (Read/Write)	1-32	1-32	1-128	1-128	1-128

The first three memory types in the above table are 16-bit word references (%AI, %AQ, %R) and the remaining memory types are bit references.

The following is the format for a word reference:

[%XXrrrr]	
%	Beginning symbol
XX	PLC word memory type (AI, AQ, R). This may be upper or lower case.
rrrr	PLC word reference number. Leading zeroes are allowed but not required.

The following is the format for a word bit reference (Read Only):

[%XXrrrr/bb]	
%	Beginning symbol
XX	PLC word memory type (AI, AQ, R). This may be upper or lower case.
rrrr	PLC word reference number. Leading zeroes are allowed but not required.
/	Character used as a delimiter between word address and bit number
bb	PLC reference number of the bit position. The bit positions are numbered from 0 to 15 with 0 being the least significant bit.

The following is the format for a byte (8-bit) reference:

[B:%XXbbbb]

B	Character designating byte reference
:	Byte designator/memory type separator
%	Beginning symbol
XX	PLC memory type (I, Q, T, M, G, S, SA, SB, SC). This may be upper or lower case.
bbbb	PLC byte reference number. This address must be a multiple of 8 + 1. Leading zeroes are allowed but not required.

The following is the format for a bit reference:

[%XXbbbb]

%	Beginning symbol
XX	PLC memory type (I, Q, T, M, G, S, SA, SB, SC). This may be upper or lower case.
bbbb	PLC reference number of the bit position. Leading zeroes are allowed but not required.

Note that General Electric Series 90 Family PLCs store double precision numbers with the first (low) register holding the least significant word and the next consecutive (high) register holding the most significant word. The PanelMate unit, however, interprets the first register as the most significant word and the next consecutive register as the least significant word. For example, if the value 1 is stored in register 624 and the value 0 is stored in register 625, General Electric would interpret the stored value as 1, while the PanelMate unit would display the value as 65536. To read a double precision number correctly, multiply the low byte by 65536 and add this value to the high byte.

## Examples

The following are examples of valid PLC references which may be assigned in the PanelMate unit expression fields.

### Series 5, 6, and 6+

#### Word References

<u>Reference</u>	<u>Description</u>
[R1024]	Register 1024
[R701]	Register 701

#### Bit References

<u>Reference</u>	<u>Description</u>
[AI233]	Auxiliary input 233
[AO466]	Auxiliary output 466
[I18]	Input 18
[O42]	Output 42
[IF+999]	input 999 of expanded channel IF+
[I7-766]	Input 766 of expanded channel I7-
[OA+643]	Output 643 of expanded channel OA+
[O6-1019]	Output 1019 of expanded channel O6-

### Series 90/30 and 90/70

#### Word References

<u>Reference</u>	<u>Description</u>
[%AI32]	Analog input 32
[%R1234]	Data register 1234

#### Byte References

<u>Reference</u>	<u>Description</u>
[B:%M65]	Discrete internal coil 65
[B:%Q9]	Discrete machine output 9

#### Bit References

[%SA32]	Bit 32 of system memory
[%T198]	Discrete temporary coil 198
[%AQ705/0]	Bit 0 of analog output 705
[%R150/15]	Bit 15 of data register 150

## Access Permitted by Maintenance Template

---

The Maintenance Template will access all memory locations supported by the PLC driver as defined in this chapter. When running online, you may change the PLC reference. The Maintenance Template is designed to assist you in specifying the PLC reference by scrolling through a list of mnemonics which are used to enter the PLC word reference. When online in the PLC reference change mode, the following list is available.

GE Series 5	"I", "O", "R", "I1+", "I2+", "I1-", "O1+", "O2+", "O1-", and "O2-"
GE Series 6	"AI", "AO", "I", "O", "R", "A", "B", "C", "D", "E", "F", "+", and "-"
GE Series 6+	"AI", "AO", "I", "O", "R", "A", "B", "C", "D", "E", "F", "+", and "-"
GE Series 90	"%AI", "%AQ", "%R", "%I", "%Q", "%M", "%T", "%G", "%S", "%SA", "%SB", "%SC", "B:", and "/"

You must enter the correct mnemonics and numeric values and create a legal reference to change a PLC reference. Once a new reference is entered, the Maintenance Template will remain in a paused state until the control button labeled "Start Monitor" is depressed. The PanelMate Series 1000 will then parse the reference. (Parsing means checking the syntax and range of the reference to ensure that it is supported by the driver.) If correct, the template begins updating.





# Chapter 33

## Mitsubishi PLCs

---

The PanelMate Series 1000 can be used with programmable controllers in the Mitsubishi Standard A Series (A0J2H, A1, A1N, A1S, A2, A2N, A3, A3N, A3H, A3M, and A73), Extended A Series (A2A, A2A(S1) and A3A), FX Series (FX-16, FX-24, FX-32, FX-48, FX-64, and FX-80), and the FXo Series (FXo-14, FXo-20, and FXo-30). Communication to the A Series PLCs will be through the AJ71C24 Computer Link Module. Communication to the FX and FXo Series will be through an RS232/RS422 converter. Communication to the FXo Series will be through the FX-20P-CADP Universal Adaptor.

# Memory

---

The following memory types are supported by the Mitsubishi A Series driver:

<u>Memory Type</u>	<u>Memory Areas</u>
<b>16-Bit Word</b>	
TN	Timer (present value) Register
CN	Counter (present value) Register
D	Data Register
W	Link Register
R	File Register
D	Special Register
<b>Bit</b>	
X	Input Relay device
Y	Output Relay device
M	Internal Relay device
L	Latch Relay device
S	Step Relay device
B	Link Relay device
F	Annunciator device
M	Special Relay device
TS	Timer (contact) device
TC	Timer (coil) device
CS	Counter (contact) device
CC	Counter (coil) device

The following memory types are supported by the Mitsubishi FX and FXo Series driver:

<u>Memory Type</u>	<u>Memory Areas</u>
<b>16-Bit Word</b>	
TN	Timer (present value) Register
CN	Counter (present value) Register (16-Bit)
CN	Counter (present value) Register (32-Bit)
D	Data Register
D	Special Register
<b>Bit</b>	
X	Input Relay device
Y	Output Relay device
M	Auxiliary Relay device
M	Special Relay device
S	State device
TS	Timer (contact) device
TC	Timer (coil) device
CS	Counter (contact) device
CC	Counter (coil) device

## Mitsubishi A Series Memory Ranges

The following tables show the word device types supported by the Mitsubishi A Series driver. Link Register addresses are hexadecimal. All other addresses are decimal. These memory types can be referenced as a single bit or 16-bit word.

Model	Timer (Present Value) Register	Counter (Present Value) Register	Data Register
A0J2H	TN0000-TN0255	CN0000-CN0255	D0000-D1023
A1	TN0000-TN0255	CN0000-CN0255	D0000-D1023
A1N	TN0000-TN0255	CN0000-CN0255	D0000-D1023
A1S	TN0000-TN0255	CN0000-CN0255	D0000-D1023
A2	TN0000-TN0255	CN0000-CN0255	D0000-D1023
A2N	TN0000-TN0255	CN0000-CN0255	D0000-D1023
A3	TN0000-TN0255	CN0000-CN0255	D0000-D1023
A3N	TN0000-TN0255	CN0000-CN0255	D0000-D1023
A3H	TN0000-TN0255	CN0000-CN0255	D0000-D1023
A3M	TN0000-TN0255	CN0000-CN0255	D0000-D1023
A73	TN0000-TN0255	CN0000-CN0255	D0000-D1023
A2A	TN000000-TN002047	CN000000-CN001023	D000000-D006143
A2A (S1)	TN000000-TN002047	CN000000-CN001023	D000000-D006143
A3A	TN000000-TN002047	CN000000-CN001023	D000000-D006143

**Note** Timer and counter registers are read only.

Model	Link Register	File Register	Special Register
A0J2H	W0000-W03FF	R0000-R8191	D9000-D9255
A1	W0000-W03FF	Not Supported	D9000-D9255
A1N	W0000-W03FF	Not Supported	D9000-D9255
A1S	W0000-W03FF	R0000-R4095	D9000-D9255
A2	W0000-W03FF	R0000-R4095	D9000-D9255
A2N	W0000-W03FF	R0000-R4095	D9000-D9255
A3	W0000-W03FF	R0000-R8191	D9000-D9255
A3N	W0000-W03FF	R0000-R8191	D9000-D9255
A3H	W0000-W03FF	R0000-R8191	D9000-D9255
A3M	W0000-W03FF	R0000-R8191	D9000-D9255
A73	W0000-W03FF	R0000-R8191	D9000-D9255
A2A	W000000-W000FFF	R000000-R008191	D009000-D009255
A2A (S1)	W000000-W000FFF	R000000-R008191	D009000-D009255
A3A	W000000-W000FFF	R000000-R008191	D009000-D009255

**Note** Special registers are read only.

The following tables show the bit device types supported by the Mitsubishi A Series driver. Input, Output, and Link Relay addresses are hexadecimal. All other addresses are decimal. These memory types can be referenced as a single bit or 16-bit word.

Model	Input Device	Output Device	Internal Relay Device
A0J2H	X0000-X01FF	Y0000-Y01FF	M0000-M2047
A1	X0000-X00FF	Y0000-Y00FF	M0000-M2047
A1N	X0000-X00FF	Y0000-Y00FF	M0000-M2047
A1S	X0000-X00FF	Y0000-Y00FF	M0000-M2047
A2	X0000-X01FF	Y0000-Y01FF	M0000-M2047
A2N	X0000-X01FF	Y0000-Y01FF	M0000-M2047
A3	X0000-X07FF	Y0000-Y07FF	M0000-M2047
A3N	X0000-X07FF	Y0000-Y07FF	M0000-M2047
A3H	X0000-X07FF	Y0000-Y07FF	M0000-M2047
A3M	X0000-X07FF	Y0000-Y07FF	M0000-M2047
A73	X0000-X07FF	Y0000-Y07FF	M0000-M2047
A2A	X000000-X0001FF	Y000000-Y0001FF	M000000-M008191
A2A (S1)	X000000-X0003FF	Y000000-Y0003FF	M000000-M008191
A3A	X000000-X0007FF	Y000000-Y0007FF	M000000-M008191

**Note** Input devices are read only.

Model	Latch Relay	Step Device	Link Relay Device
A0J2H	L0000-L2047	S0000-S2047	B0000-B03FF
A1	L0000-L2047	S0000-S2047	B0000-B03FF
A1N	L0000-L2047	S0000-S2047	B0000-B03FF
A1S	L0000-L2047	S0000-S2047	B0000-B03FF
A2	L0000-L2047	S0000-S2047	B0000-B03FF
A2N	L0000-L2047	S0000-S2047	B0000-B03FF
A3	L0000-L2047	S0000-S2047	B0000-B03FF
A3N	L0000-L2047	S0000-S2047	B0000-B03FF
A3H	L0000-L2047	S0000-S2047	B0000-B03FF
A3M	L0000-L2047	S0000-S2047	B0000-B03FF
A73	L0000-L2047	S0000-S2047	B0000-B03FF
A2A	L000000-L008191	S000000-S008191	B000000-B000FFF
A2A (S1)	L000000-L008191	S000000-S008191	B000000-B000FFF
A3A	L000000-L008191	S000000-S008191	B000000-B000FFF

Model	Annunciator Device	Special Relay Device	Timer (Contact) Device
A0J2H	F0000-F0255	M9008-M9247	TS0000-TS0255
A1	F0000-F0255	M9008-M9247	TS0000-TS0255
A1N	F0000-F0255	M9008-M9247	TS0000-TS0255
A1S	F0000-F0255	M9008-M9247	TS0000-TS0255
A2	F0000-F0255	M9008-M9247	TS0000-TS0255
A2N	F0000-F0255	M9008-M9247	TS0000-TS0255
A3	F0000-F0255	M9008-M9247	TS0000-TS0255
A3N	F0000-F0255	M9008-M9247	TS0000-TS0255
A3H	F0000-F0255	M9008-M9247	TS0000-TS0255
A3M	F0000-F0255	M9008-M9247	TS0000-TS0255
A73	F0000-F0255	M9008-M9247	TS0000-TS0255
A2A	F000000-F002047	M009000-M009255	TS000000-TS002047
A2A (S1)	F000000-F002047	M009000-M009255	TS000000-TS002047
A3A	F000000-F002047	M009000-M009255	TS000000-TS002047

**Note** Special relay devices are read only.

Special relay devices M9000-M9007 and M9248-M9255 cannot be read directly by the PanelMate unit for the models shown. However, ladder logic could be written to set and clear readable devices, such as link relay devices based on the status of these specific bits. The PanelMate unit could then reference the readable devices.

Model	Timer (Coil) Device	Counter (Contact) Device	Contact (Coil) Device
A0J2H	TC0000-TC0255	CS0000-CS0255	CC0000-CC0255
A1	TC0000-TC0255	CS0000-CS0255	CC0000-CC0255
A1N	TC0000-TC0255	CS0000-CS0255	CC0000-CC0255
A1S	TC0000-TC0255	CS0000-CS0255	CC0000-CC0255
A2	TC0000-TC0255	CS0000-CS0255	CC0000-CC0255
A2N	TC0000-TC0255	CS0000-CS0255	CC0000-CC0255
A3	TC0000-TC0255	CS0000-CS0255	CC0000-CC0255
A3N	TC0000-TC0255	CS0000-CS0255	CC0000-CC0255
A3H	TC0000-TC0255	CS0000-CS0255	CC0000-CC0255
A3M	TC0000-TC0255	CS0000-CS0255	CC0000-CC0255
A73	TC0000-TC0255	CS0000-CS0255	CC0000-CC0255
A2A	TC000000-TC002047	CS000000-CS001023	CC000000-CC001023
A2A (S1)	TC000000-TC002047	CS000000-CS001023	CC000000-CC001023
A3A	TC000000-TC002047	CS000000-CS001023	CC000000-CC001023

## Mitsubishi FX Series Memory Ranges

The following tables show the word device types supported by the Mitsubishi FX Series driver. All addresses are decimal. These memory types can be referenced as a single bit or 16-bit words unless otherwise noted.

Model	Timer (Present Value) Register	Counter (Present Value) Register	Data Register	Special Register
FX-16	TN000-TN255	CN000-CN199 (16-bit) CN200-CN255 (32-bit)	D000-D511	D8000-D8255
FX-24	TN000-TN255	CN000-CN199 (16-bit) CN200-CN255 (32-bit)	D000-D511	D8000-D8255
FX-32	TN000-TN255	CN000-CN199 (16-bit) CN200-CN255 (32-bit)	D000-D511	D8000-D8255
FX-48	TN000-TN255	CN000-CN199 (16-bit) CN200-CN255 (32-bit)	D000-D511	D8000-D8255
FX-64	TN000-TN255	CN000-CN199 (16-bit) CN200-CN255 (32-bit)	D000-D511	D8000-D8255
FX-80	TN000-TN255	CN000-CN199 (16-bit) CN200-CN255 (32-bit)	D000-D511	D8000-D8255

**Note** The following Special Registers are read only.

D8001-D8012  
D8028-D8029  
D8040-D8067  
D8069-D8070

**Note** Data Registers using bit references are read only.

The following tables show the bit device types supported by the Mitsubishi FX Series driver. Input Relay and Output Relay addresses are octal. All other addresses are decimal. These memory types can be referenced as a single bit or 16-bit word (must be a multiple of 16).

Model	Input Relay Device	Output Relay Device	Auxiliary Device
FX-16	X000-X177	Y000-Y177	M0000-M1023
FX-24	X000-X177	Y000-Y177	M0000-M1023
FX-32	X000-X177	Y000-Y177	M0000-M1023
FX-48	X000-X177	Y000-Y177	M0000-M1023
FX-64	X000-X177	Y000-Y177	M0000-M1023
FX-80	X000-X177	Y000-Y177	M0000-M1023

**Note** Input Relay Devices are read only.

Model	Special Relay Device	State Device	Timer (Contact) Device
FX-16	M8000-M8255	S000-S999	TS000-TS255
FX-24	M8000-M8255	S000-S999	TS000-TS255
FX-32	M8000-M8255	S000-S999	TS000-TS255
FX-48	M8000-M8255	S000-S999	TS000-TS255
FX-64	M8000-M8255	S000-S999	TS000-TS255
FX-80	M8000-M8255	S000-S999	TS000-TS255

**Note** The following Special Relay Devices are read only.

M8000-M8014  
M8020-M8021  
M8029  
M8046  
M8048  
M8060-M8067  
M8072-M8073

**Note** Word writes to State Device S992 are not allowed.

Model	Timer (Coil) Device	Counter (Contact) Device	Counter (Coil) Device
FX-16	TC000-TC255	CS000-CS255	CC000-CC255
FX-24	TC000-TC255	CS000-CS255	CC000-CC255
FX-32	TC000-TC255	CS000-CS255	CC000-CC255
FX-48	TC000-TC255	CS000-CS255	CC000-CC255
FX-64	TC000-TC255	CS000-CS255	CC000-CC255
FX-80	TC000-TC255	CS000-CS255	CC000-CC255

## Mitsubishi FXo Series Memory Ranges

The following tables show the word device types supported by the Mitsubishi FXo Series driver. All addresses are decimal. These memory types can be referenced as a single bit or 16-bit words unless otherwise noted.

Model	Timer (Present Value) Register	Counter (Present Value) Register	Data Register	Special Register
FXo-14	TN00-TN55	CN00-CN15 (16-bit) CN235-CN249 (32-bit) CN251-CN254 (32-bit)	D00-D31	D8000-D8069
FXo-20	TN00-TN55	CN00-CN15 (16-bit) CN235-CN249 (32-bit) CN251-CN254 (32-bit)	D00-D31	D8000-D8069
FXo-30	TN00-TN55	CN00-CN15 (16-bit) CN235-CN249 (32-bit) CN251-CN254 (32-bit)	D00-D31	D8000-D8069

**Note** The following Special Registers are read only.

D8001-D8013  
D8028-D8029  
D8040-D8067  
D8069

The following tables show the bit device types supported by the Mitsubishi FXo Series driver. Input Relay and Output Relay addresses are octal. All other addresses are decimal. These memory types can be referenced as a single bit or 16-bit word (must be a multiple of 16).

Model	Input Relay Device	Output Relay Device	Auxiliary Device
FXo-14	X00-X17	Y00-Y15	M000-M511
FXo-20	X00-X17	Y00-Y15	M000-M511
FXo-24	X00-X17	Y00-Y15	M000-M511

**Note** Input Relay Devices are read only.

**Note** Word writes to Output Relay Device Y0 are not allowed.

Model	Special Relay Device	State Device	Timer (Contact) Device
FXo-14	M8000-M8254	S00-S63	TS00-TS55
FXo-20	M8000-M8254	S00-S63	TS00-TS55
FXo-30	M8000-M8254	S00-S63	TS00-TS55

**Note** The following Special Relay Devices are read only.

M8000-M8022  
M8029  
M8061  
M8065-M8067  
M8246-M8254

**Note** Word writes to Timer (Contact) Device TS48 are not allowed.

Model	Timer (Coil) Device	Counter (Contact) Device	Counter (Coil) Device
FXo-14	TC00-TC55	CS00-CS15 CS235-CS249 CS251-CS254	CC00-CC15 CC235-CC249 CC251-CC254
FXo-20	TC00-TC55	CS00-CS15 CS235-CS249 CS251-CS254	CC00-CC15 CC235-CC249 CC251-CC254
FXo-30	TC00-TC55	CS00-CS15 CS235-CS249 CS251-CS254	CC00-CC15 CC235-CC249 CC251-CC254

**Note** Word writes to Timer (Coil) Device TC48 are not allowed.

**Note** Word writes to Counter (Contact) Devices CS240 are not allowed.

**Note** Word writes to Counter (Coil) Devices CC240 are not allowed.

# Possible Configurations

---

The following sections describe some of the possible configurations of the PanelMate unit with Mitsubishi PLCs. Network to network communication is not supported by the Mitsubishi driver.

## Direct

---

Direct connection between a PanelMate unit and a Mitsubishi A Series processor.

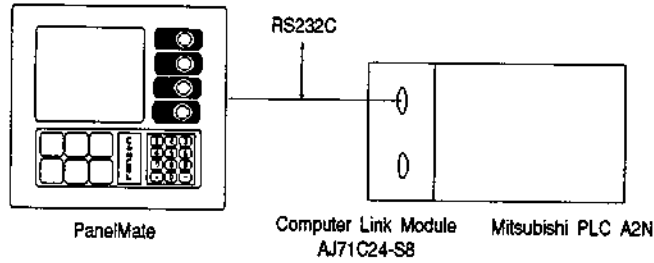


Figure 33-1 Direct Connection

Direct connection between a PanelMate unit and a Mitsubishi FX Series processor.

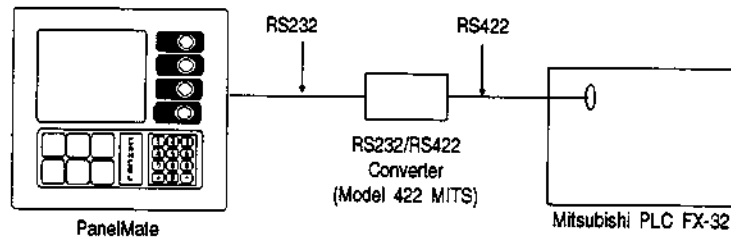


Figure 33-2 Direct Connection

**Note** An RS422 cable is required. For pinout information, refer to figure 33-7.

Direct connection between a PanelMate unit and a Mitsubishi FXo Series processor.

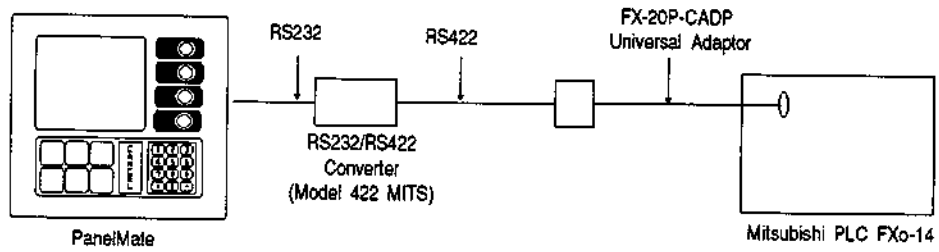


Figure 33-3 Direct Connection

**Note** An RS422 cable is required. For pinout information, refer to figure 33-7.

## Network (Mitsubishi A Series only)

The following figure shows a network consisting of three devices and a PanelMate unit.

**Note** You could also use RS422 cabling to connect the PanelMate unit to the Mitsubishi A Series PLC.

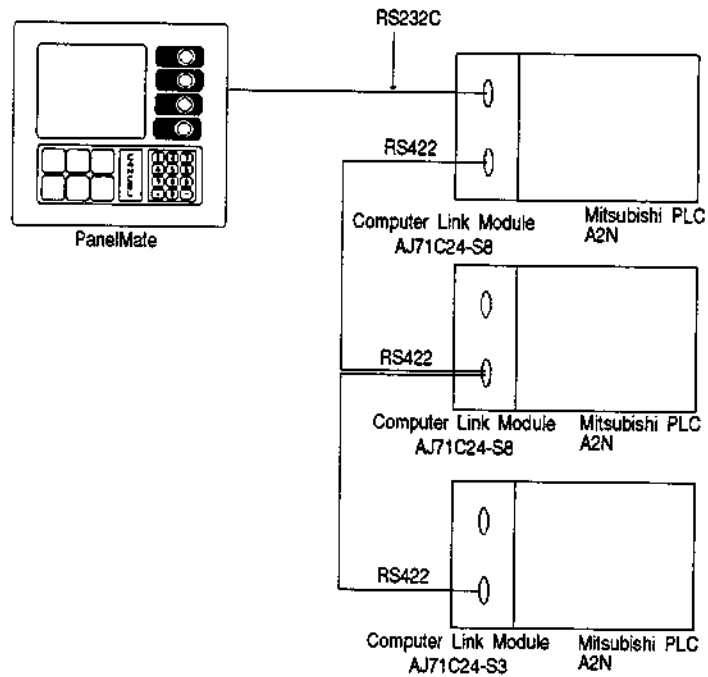


Figure 33-4 Network Connection

# Cabling

The following figures show the cable configuration between a PanelMate unit and the AJ71C24 module for the Mitsubishi A Series PLCs. The Mitsubishi A Series driver supports RS232C and RS422 communications. The maximum cable length when using RS232 is 50 feet, while the maximum cable length for RS422 is 4000 feet. RS422 cable must be a twisted double-wire shielded cable. All PanelMate unit ports are female 9-pin (DB-9S), so the connectors on the cables must be male 9-pin (DB-9P).

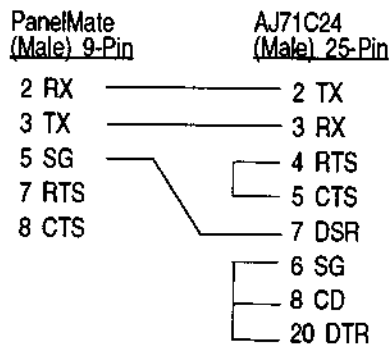


Figure 33-5 RS232 Cabling for AJ71C24 Module (Mitsubishi A Series)

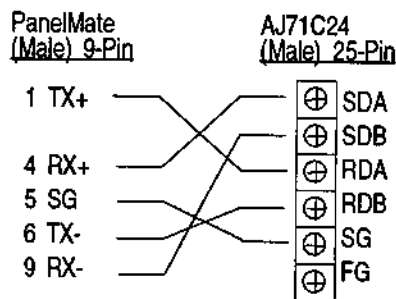


Figure 33-6 RS422 Cabling for AJ71C24 Module (Mitsubishi A Series)

The Mitsubishi FX and FXo Series requires an RS232/RS422 converter to communicate with the PanelMate Series. The following figures show the cable configuration between a PanelMate unit and the RS232/RS422 converter for the Mitsubishi FX and FXo Series PLCs. Note that the Mitsubishi FXo Series has a built-in non-standard port which communicates RS422. To communicate to the PanelMate Series, you must also use an FX-20P-CADP Universal Adaptor which converts the port to a 25-pin port. The maximum cable length when using RS232 is 50 feet, while the maximum cable length for RS422 is 4000 feet. RS422 cable must be a twisted double-wire shielded cable. All PanelMate unit ports are female 9-pin (DB-9S), so the connectors on the cables must be male 9-pin (DB-9P).

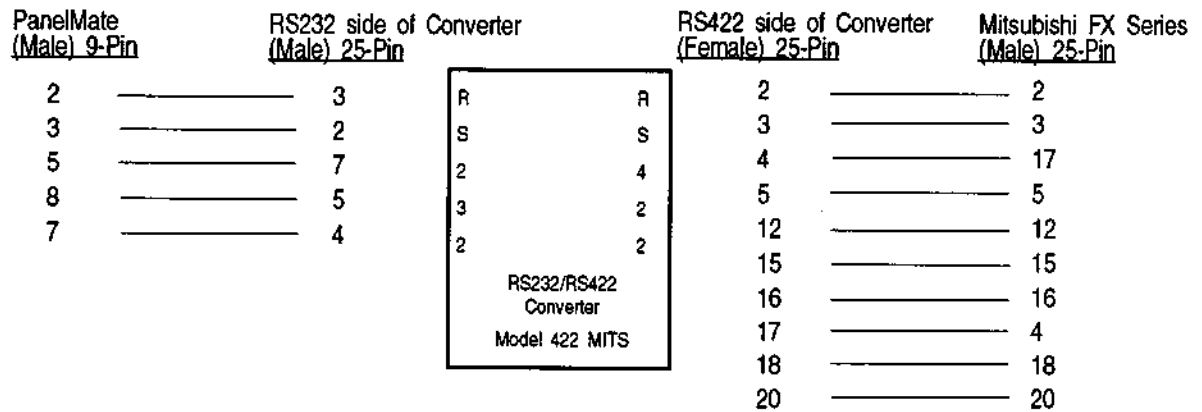


Figure 33-7 RS232/RS422 Converter Cabling for the Mitsubishi FX Series PLCs

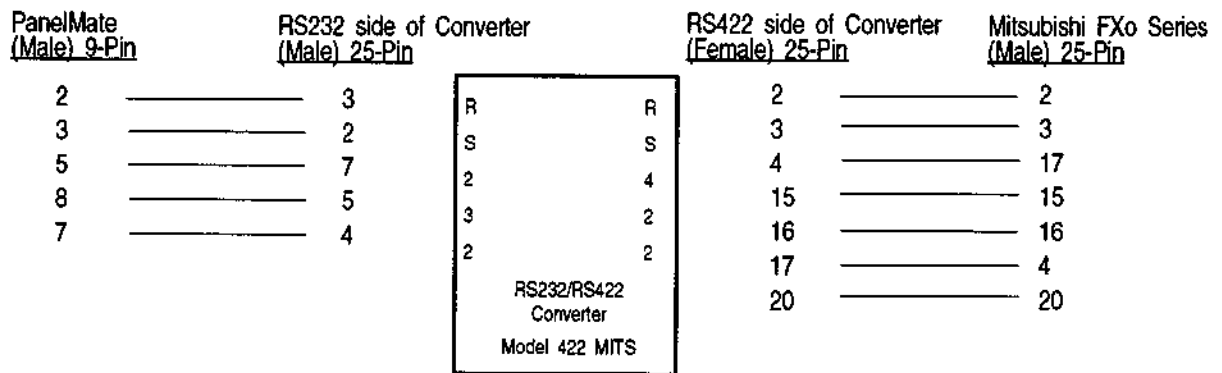


Figure 33-8 RS232/RS422 Converter Cabling for the Mitsubishi FXo Series PLCs

# Communications Parameters

---

The standard communications parameters for communicating to Mitsubishi A Series PLCs are:

Baud rate	300 through 19200
Data bits	8
Parity	Even
Stop bits	1

**Note** The settings for parameters, such as baud rate, must match the parameters set for the PanelMate unit

The standard communications parameters for communicating to Mitsubishi FX and FXo Series PLCs are:

Baud rate	9600
Data bits	7
Parity	Even
Stop bits	1

## AJ71C24 Computer Link Module

The AJ71C24 module is the interface between the PanelMate unit and the Mitsubishi PLCs. It has one RS232C and one RS422 port. Refer to the following tables for configuration information.

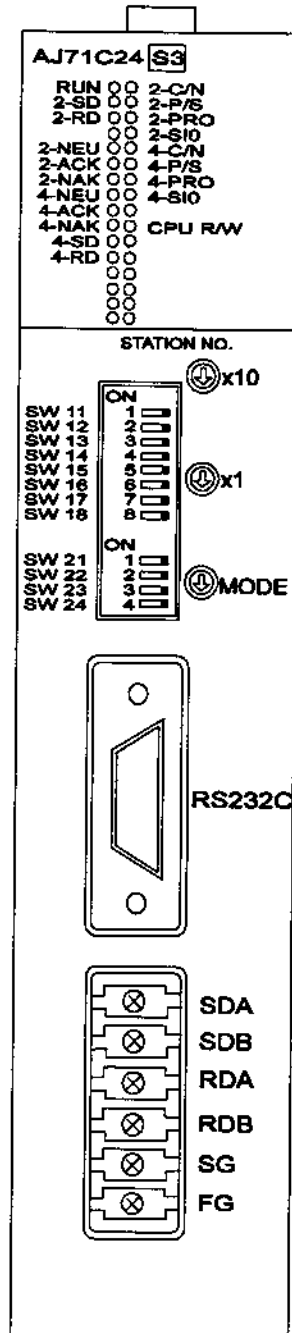


Figure 33-9 AJ71C24-S3 Module

The following table describes the LED signals on the AJ71C24 module and gives a brief description of their function. Refer to figure 33-9 to locate the LEDs.

<u>LED</u>	<u>Description</u>
RUN	Normal run
2-SD	RS232C transmitting
2-RD	RS232C receiving
2-NEU	RS232C neutral
2-ACK	RS232 ACK
2-NAK	RS232 NAK
4-NEU	RS422 neutral
4-ACK	RS422 ACK
4-NAK	RS422 NAK
4-SD	RS422 transmission status
4-RD	RS422 received data status
2-C/N	Result of RS-232C and PC CPU communications
2-P/S	RS232 parity/sum check error
2-PRO	RS232C protocol error
2-SIO	RS232C SIO error
4-C/N	Result of RS422 and PC CPU communications
4-P/S	RS422 parity/sum check error
4-PRO	RS422 protocol error
4-SIO	RS422 SIO error
CPUW/W	Communications with PC CPU

**Table 33-1 LED Signals and Descriptions**

The station numbers are located below the LEDs and can be set in the range from 0 to 31. Set the X10 station number to the tens digit in the station number and set the X1 switch to the ones digit in the station number. The station number may be set to any value which does not duplicate another station number. Station numbers do not have to be sequential.

The mode setting switch is located below the station numbers and selects the transmission control protocol. The mode setting switch must be set to 1, 5, or A for communications to the PanelMate unit. Those selections enable Protocol 1. The method of setting the transmission control protocol and the meaning of the switch settings are described in the table below.

Mode Setting Switch Number	Mode Settings		Notes
	RS232C	RS422	
0	Unusable	Unusable	
1	Protocol 1	No protocol	For connection of computers to RS232C and RS422 individually, or for connection of a printer to the no protocol interface. Both the interfaces work independently.
2	Protocol 2	No protocol	
3	Protocol 3	No protocol	
4	Protocol 4	No protocol	
5	No protocol	Protocol 1	
6	No protocol	Protocol 2	
7	No protocol	Protocol 3	
8	No protocol	Protocol 4	
9	No protocol	No protocol	This mode is used to enable a no protocol computer link with all devices connected to the RS232C and RS422 interfaces. Data transmitted by a computer can be received by all AJ71C24 modules.
A	Protocol 1	Protocol 1	This mode is used to enable a dedicated protocol computer link with all devices connected to the RS232C and RS422 interfaces. Data transmitted by a computer can be received by the AJ71C24 designated by the send message.*
B	Protocol 2	Protocol 2	
C	Protocol 3	Protocol 3	
D	Protocol 4	Protocol 4	
E	Unusable	Unusable	
F	Module test	Module Test	RS232C and RS422 operate independently.

**Table 33-2 Protocol Settings**

- \* When the mode switch is set from 9 to D, the RS232C and the RS422 interfaces operate as if interlocked with each other.

The following table lists and describes the dipswitch setting for the AJ71C24 module.

Switch	Description			ON		OFF		Notes	
SW11	Main channel settings			RS422		RS232C		Valid for modes A to D	
SW12	Data length			8 bits		7 bits		-	
SW13 SW14 SW15	Baud Rate Transmission Speed Setting	300 OFF OFF OFF	600 ON OFF OFF	1200 OFF ON OFF	2400 ON ON OFF	400 OFF OFF ON	9600 ON OFF ON	19200 OFF ON ON	Unusable ON ON ON
SW16	Parity check			Enabled		Disabled		-	
SW17	Parity setting			Even		Odd		Valid only when parity check enabled is selected	
SW18	Stop bit			2 bits		1 bit			
SW21	Sum check			*Enabled		Disabled			
SW22	Write during RUN			*Enabled		Disabled			
SW23	Send area terminal resistance			Present		Absent		Valid only when RS422 is used	
SW24	Receive area terminal resistance			Present		Absent			

**Table 33-3 Dipswitch Settings for the AJ71C24 Module**

\* These settings are not optional and must be set as indicated.

# Mitsubishi Word and Bit References

---

The following section describes the use of Mitsubishi word and bit references in your configuration. The general word referencing method is:

[plcname,word#format]

The "plcname" is the name of the designated PLC as listed in the PLC Name and Port Table. The "word" is the reference memory type and number (address) of the word or register to be read or written. The "#format" is a code which specifies the format of the data being read or written. The "plcname" and "#format" are optional if you are using the default PLC and do not wish to change the data format, respectively.

The general bit device referencing method is:

[plcname,bit]

The "plcname" is the designated PLC as listed in the PLC Name and Port Table. The "bit" is the reference memory type and number (address) of the bit, coil, or input to be written or read. See chapter 10 for a more detailed explanation of word and bit references, including format descriptions.

The Mitsubishi A Series driver is supported on the PanelMate unit for models AOJ2H, A1, A1N, A1S, A2, A2N, A3, A3N, A3H, A3M, A73, A2A, A2A(S1), and A3A. These models use a combination of decimal and hexadecimal addresses. Bit references are from 0 to 15. The PanelMate unit's format default is S16.

The following list contains the memory types supported by the Mitsubishi A Series driver.

- TN - timer (present value) register
- CN - counter (present value) register
- D - data register
- W - link register
- R - file register
- D - special register
- X - input relay device
- Y - output relay device
- M - internal relay device
- L - latch relay device
- S - step relay device
- B - link relay device
- F - annunciator device
- M - special relay device
- TS - timer (contact) device
- TC - timer (coil) device
- CS - counter (contact) device
- CC - counter (coil) device

The Mitsubishi Series FX and FXo driver is supported on the PanelMate unit for models FX-16, FX-24, FX-32, FX-48, FX-64, FX-80, FXo-14, FXo-20, and FXo-30. These models use a combination of octal and decimal addresses. Bit references are from 0 to 15. The PanelMate unit's format default is S16.

The following list contains the memory types supported by the Mitsubishi Series FX and FXo driver.

- TN - timer (present value) register
- CN - counter (present value) register
- D - data register
- D - special register
- X - input relay device
- Y - output relay device
- M - auxilliary relay device
- M - special relay device
- S - state device
- TS - timer (contact) device
- TC - timer (coil) device
- CS - counter (contact) device
- CC - counter (coil) device

The following is the format for referencing 16-bit or 32-bit (CN only) words.

[plcname,MMXXXX]

- |         |   |
|---------|---|
| plcname | Optional PLC name found in the PLC Name Table. If left blank, the default name is used. |
| ,       | Optional PLC name delimiter.  |
| MM      | The word device memory type (e.g., D, W, CN).   |
| XXXX    | The word number; maximum of 4 characters; leading zeroes are allowed.                   |

The following is the format for referencing a single bit in a word device.

[plcname,MMXXXX/BB]

- |         |   |
|---------|---|
| plcname | Optional PLC name found in the PLC Name Table. If left blank, the default name is used. |
| ,       | Optional PLC name delimiter.  |
| MM      | The word device memory type (e.g., D, W, CN).   |
| XXXX    | The element number; maximum of 4 characters; leading zeroes are allowed.                |
| /       | Bit delimiter character.  |
| BB      | Bit number in the range 00-15; leading zeroes is allowed.                               |

**Note** Single bits referenced in a word are read only.

The following is the format for referencing bits in a bit device as a 16-bit word.

[plcname,W:MMXXXX]

plcname	Optional PLC name found in the PLC Name Table. If left blank, the default name is used.
,	Optional PLC name delimiter.
W	Letter designating a 16-bit word.
:	16-bit delimiter character.
MM	The bit device memory type (e.g. X, Y, TC, etc.)
XXXX	The starting bit number; must be a multiple of 16 (e.g., 0, 16, 32, 48, etc. for decimal addressing and 0, 20, 40, 60, etc. for octal addressing).

The following is the format for referencing a single bit in a bit device.

[plcname,MMXXXX]

plcname	Optional PLC name found in the PLC Name Table. If left blank, the default name is used.
,	Optional PLC name delimiter.
MM	The bit device memory type (e.g., X, Y, TC, etc.)
XXXX	The bit number; maximum of 4 characters; leading zeroes are allowed.

The supported Mitsubishi PLC models will allow a maximum of 32 contiguous words per read. The maximum number of unused words before another read is generated is 15 for Mitsubishi A Series PLCs and 31 for the Mitsubishi FX and FXo Series PLCs.

## Examples

The following are examples of valid PLC references which may be assigned in the PanelMate unit's expression fields.

### Mitsubishi A Series

#### Word References

<u>Reference</u>	<u>Description</u>
[TN13]	Word 13 is referenced in timer memory
[CN125]	Word 125 is referenced in counter memory
[D3]	Word 3 is referenced in data register memory
[Wff]	Word 255 is referenced in link register memory
[R8002]	Word 8002 is referenced in file register memory
[D9111]	Word 9111 is referenced in special register memory
[W:X1F0]	Word starting at bit 1F0 (496) in input memory
[W:Y0]	Word starting at bit 0 in output memory
[W:M1024]	Word starting at bit 1024 in internal relay memory
[W:L16]	Word starting at bit 16 in latch relay memory
[W:S256]	Word starting at bit 256 in step relay memory
[W:B3F0]	Word starting at bit 3F0 (1008) in link relay memory
[W:F128]	Word starting at bit 128 in annunciator memory
[W:TS240]	Word starting at bit 240 in timer (contact) memory
[W:TC32]	Word starting at bit 32 in timer (coil) memory
[W:CS48]	Word starting at bit 48 in counter (contact) memory
[W:CC64]	Word starting at bit 64 in counter (coil) memory

### Bit References

<u>Reference</u>	<u>Description</u>
[X0003]	Bit 3 is referenced in input memory
[Y7]	Bit 7 is referenced in output memory
[M006555]	Bit 6555 is referenced in internal relay memory
[M999]	Bit 999 is referenced in auxilliary relay memory
[L005444]	Bit 5444 is referenced in latch relay memory
[S008000]	Bit 8000 is referenced in step relay memory
[S63]	Bit 63 is referenced in state relay memory
[B7]	Bit 7 is referenced in link relay memory
[F002007]	Bit 2007 is referenced in annunciator memory
[M009200]	Bit 9200 is referenced in special relay memory
[TS001999]	Bit 1999 is referenced in timer (contact) memory
[TC001888]	Bit 1888 is referenced in timer (coil) memory
[CS001000]	Bit 1000 is referenced in counter (contact) memory
[CC000999]	Bit 999 is referenced in counter (coil) memory
[TN123/13]	Word 123, bit 13 is referenced in timer memory
[CN125/12]	Word 125, bit 12 is referenced in counter memory
[D3/04]	Word 3, bit 4 is referenced in data register memory
[W9b/09]	Word 155, bit 9 is referenced in link register memory
[R8002/02]	Word 8002, bit 2 is referenced in file register memory
[D9111/10]	Word 9111, bit 10 is referenced in special register memory

## Mitsubishi FX Series

### Word References

<u>Reference</u>	<u>Description</u>
[TN114]	Word 114 is referenced in timer memory
[CN125]	Word 125 is referenced in counter memory
[D3]	Word 3 is referenced in data register memory
[D8111]	Word 8111 is referenced in special register memory
[W:X60]	Word starting at bit 60 (48) is referenced in input relay memory
[W:M16]	Word starting at bit 16 is referenced in auxilliary memory
[W:TC128]	Word starting at bit 128 is referenced in timer (coil) memory
[W:CS80]	Word starting at bit 80 is referenced in counter (contact) memory
[CN224]	Word 224 (32-bit) is referenced in counter memory

### Bit References

<u>Reference</u>	<u>Description</u>
[X14]	Bit 14 is referenced in input relay memory
[Y7]	Bit 7 is referenced in output relay memory
[M98]	Bit 98 is referenced in auxilliary memory
[M8025]	Bit 8025 is referenced in special relay memory
[S58]	Bit 58 is referenced in state memory
[TS125]	Bit 125 is referenced in timer (contact) memory
[TC87]	Bit 87 is referenced in timer (coil) memory
[CS133]	Bit 133 is referenced in counter (contact) memory
[CC201]	Bit 201 is referenced in counter (coil) memory

## Mitsubishi FXo Series

### Word References

<u>Reference</u>	<u>Description</u>
[TN18]	Word 13 is referenced in timer memory
[CN246]	Word 246 is referenced in counter memory
[D17]	Word 17 is referenced in data register memory
[D8032]	Word 8032 is referenced in special register memory
[W:Y0]	Word starting at bit 0 is referenced in output relay memory
[W:S20]	Word starting at bit 20 (16) is referenced in state device memory
[W:TS40]	Word starting at bit 40 (32) is referenced in timer (contact) register memory
[W:CC0]	Word starting at bit 0 is referenced in counter (coil) memory.

### Bit References

<u>Reference</u>	<u>Description</u>
[X17]	Bit 17 is referenced in input relay memory
[Y15]	Bit 15 is referenced in output relay memory
[M444]	Bit 444 is referenced in auxilliary memory
[M8024]	Bit 8024 is referenced in special relay memory
[S24]	Bit 24 is referenced in state memory
[TS28]	Bit 28 is referenced in timer (contact) memory
[TC12]	Bit 12 is referenced in timer (coil) memory
[CS253]	Bit 253 is referenced in counter (contact) memory
[CC237]	Bit 237 is referenced in counter (coil) memory

## Access Permitted by Maintenance Template

---

The Maintenance Template will access all memory locations supported by the PLC driver as defined in this chapter. When running online, you may change the PLC reference. The Maintenance Template is designed to assist you in specifying the PLC reference by scrolling through a list of mnemonics which are used to enter the PLC word reference. When online in the PLC reference change mode, the following list is available for the Mitsubishi A Series.

"TN", "CN", "D", "W", "R", "/", "X", "Y", "M", "L", "S", "B", "F", "TS",  
"TC", "CS", "CC", "W:", "A", "B", "C", "D", "E", and "F"

The following list is available for the Mitsubishi FX Series.

"X", "Y", "M", "S", "TS", "TC", "CS", "CC", "TN", "CN", "D", "W:", and "/"

You must enter the correct mnemonics and numeric values and create a legal reference to change a PLC reference. Once a new reference is entered, the Maintenance Template will remain in a paused state until the control button labeled "Start Monitor" is depressed. The PanelMate Series 1000 will then parse the reference. (Parsing means checking the syntax and range of the reference to ensure that it is supported by the driver.) If correct, the template begins updating.





# Chapter 34

## Modicon Controllers

---

The PanelMate Series 1000 can be used with any of the Modicon PLCs that have Modbus capability. You may use the Modbus ASCII mode driver or the Modbus RTU mode driver to communicate Modbus to Modicon PLCs. The driver takes responsibility for communications to this programmable controller, generating the protocol necessary to request information from and send information to the PLC. The PLCs simply respond to these requests and commands. No ladder logic is required in the PLC to support the interface to the PanelMate unit. The information in this chapter is for the Modbus ASCII and Modbus RTU mode drivers only. Depending on the driver selected in the PLC Name and Port Parameter table, you must select either ASCII or RTU mode to communicate to a PanelMate unit.

# Memory

The following memory types are supported by this driver.

0XXX 0XXXX 0XXXXX	Coils/discrete outputs
1XXX 1XXXX 1XXXXX	Discrete inputs (read only)
3XXX 3XXXX 3XXXXX	Input registers (read only)
4XXX 4XXXX 4XXXXX	Holding/output registers

**Note** The Modicon PLC model 984-785 allows six-digit addressing.  
The maximum address for 984-785 coil/discrete outputs is 065504.  
The maximum address for 984-785 discrete inputs is 165504.  
The maximum address for 984-785 input registers is 364992.  
The maximum address for 984-785 holding/output registers is 457766.

## Possible Configurations

Examples of possible connections are described and shown in the following pages.

### Direct

A direct connection to a Modicon PLC with built-in Modbus, without the need for any additional modules.

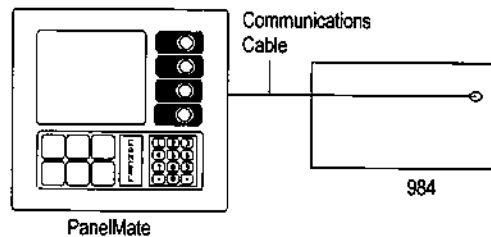


Figure 34-1 Direct Connection

Models without built-in Modbus require a Modbus adapter.

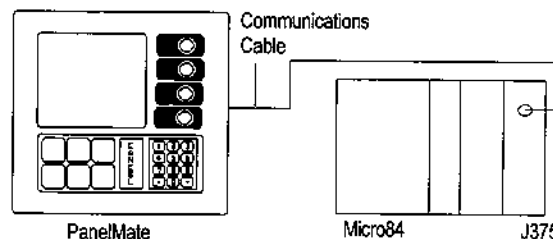


Figure 34-2 Connection using Modbus Adapter

## Multiple PLCs on a Single Modbus

If the PanelMate unit is to communicate with multiple PLCs on a single Modbus network, it requires its own Modbus modem to provide the necessary interface.

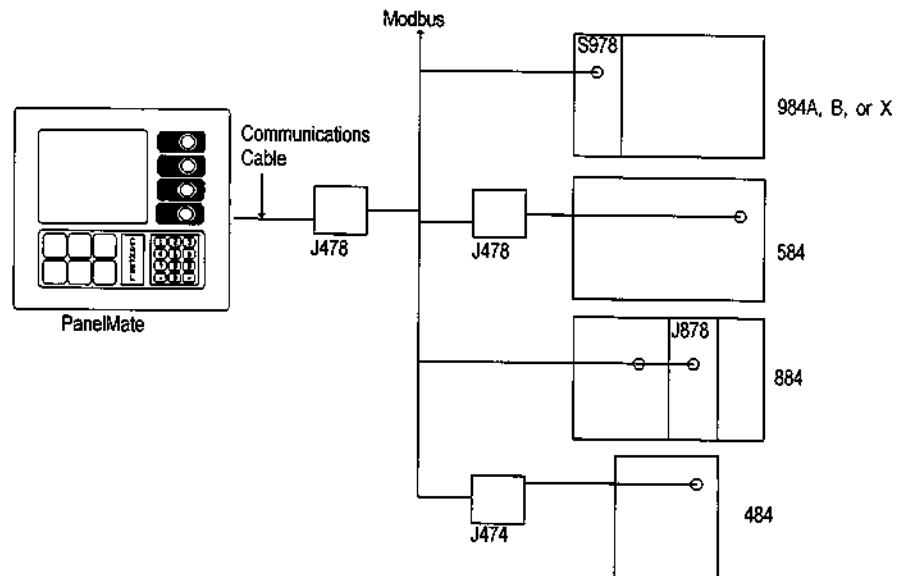


Figure 34-3 Multiple PLCs on Modbus

The following table shows the Modicon PLCs, adapters, and cable connectors. Consult the proper Modicon manual for any information not contained in this manual.

\* 984-120, 984-130, 984-145

\*\* Models 984-385/485/685/785 have one Modbus port and one Modbus Plus port.

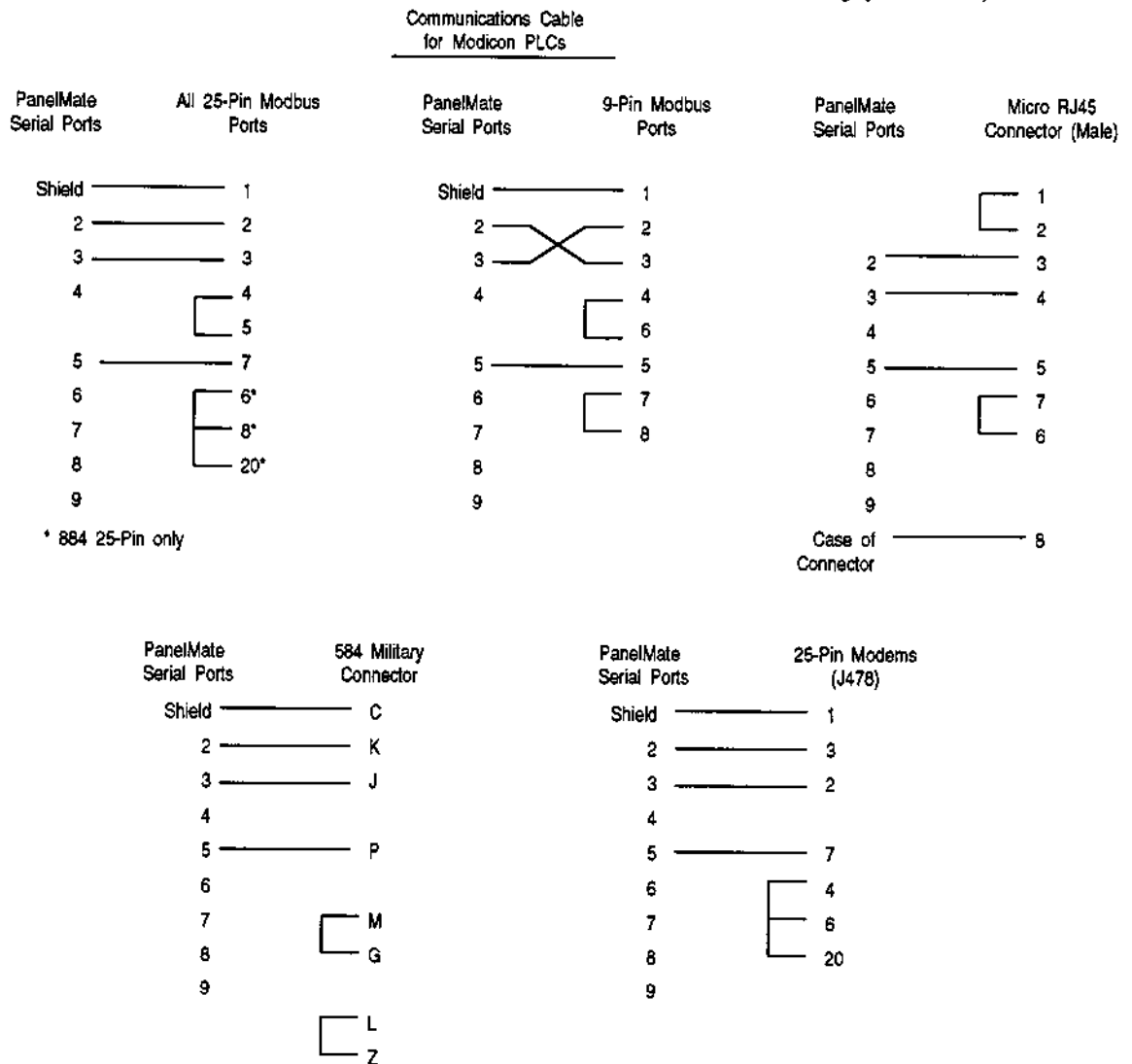
Model	984 A&B	984-X	984-381/ -480/-680 780	984-380	984-1XX*	884	584	484	μ84	Micro
# Modbus ports built-in	3	2	2**	1	1	2	2	None	None	1
Modbus Adapter	N/A	N/A	N/A	N/A	N/A	N/A	N/A	J474	J375	N/A
Modbus Modem	S978	S978	J878	J878	J478	J478	J478	J474/475	J378	JXXX
Cable Connector	DB-25P	DB-25P	DE-9P	DB-9P	DB-9P	DB-25P	Military	30-Pin	DB-25P	RJ45
Port(s)	1,2,3	1,2	1,2	1	1	1,2	1,2	1	1	1

Table 34-1 Adapters & Cable Connectors for Modicon PLCs

# Cabling

Communications between the PanelMate unit and Modbus is RS232C. The recommended maximum cable length is 50 cable feet. You should construct a communications cable of the desired length for each connection to be made. Note that the cable configuration is similar for the various Modicon PLCs and modems. All the PanelMate unit's ports are female 9-pin (DB-9S), so the connectors on the cables must be male 9-pin (DB-9P).

(You may also use a standard Modicon W190 cable instead of constructing your own.)



**Figure 34-4 Cabling Diagrams**

For applications requiring additional Modbus ports, it is recommended that Modbus expanders be used. Modbus Port Expanders from Modicon may be used to connect multiple PanelMate units to a single PLC. The PanelMate unit communications cable previously described may be used to connect the PanelMate unit and the PLCs to a Modbus Port Expander.

# Communications Parameters

---

For each Modicon port used, certain parameters must be set in order to establish communications with the PanelMate unit. This is accomplished either through DIP switch settings on the individual module or programming selections using the Modicon P230 Programmer.

Standard communication parameters for communicating with Modicon PLCs are:

- 7 data bits for ASCII mode and 8 data bits for RTU mode
- 1 stop bit\*
- 9600 baud rate
- ASCII or RTU mode\*\*
- Parity - None

\* 2 stop bits for 984-38X, 984-48X, 984-68X

\*\*Depending on the driver selected in the PLC Name and Port Parameter table, you must select either ASCII or RTU mode to communicate to a PanelMate unit. All other parameters should be configured as listed above.

**Note** The following is a summary of the information available at the time of this manual's printing, describing the necessary settings for each PLC model. Be sure to check with Modicon for any possible updates or changes if you encounter any difficulty.

## 984 and 584 Modbus Ports

---

The Modicon P230 Programmer is used to set the communications parameters of the 984 and 584 Modbus ports.

For the PLC address, use the number that coincides with the PLC ID# you have established for this unit in the PLC Name and Port Editor.

Depending on the driver selected in the PLC Name and Port Parameter table, select ASCII or RTU mode.

Be sure to match the baud rate, parity, data bits, and stop bits with the entries made in the PLC Name and Port Editor.

### 984-38X, -48X, -68X and -78X

The 984-38X, -48X, -68X, and -78X models contain a switch to determine whether port parameters will be set up using the DIP switches or configured with the P230 programmer. See the Modicon manual for your specific PLC for information on the DIP switch settings. A switch is used to determine if the memory or the DIP switch is actually controlling the port parameters. Modicon recommends that the DIP switch setting remain in RTU mode so that a maintenance person can plug in a local Data Access Panel by selecting the DIP switches.

## 884 Modbus Ports

---

Modbus port 1 parameters may only be configured using the Modicon P230 Programming Panel. Port 2 parameters may be set either by the Programming Panel or by DIP switches.

Port 1 is factory-set to the following parameters:

- Data Bits - 7 (fixed)
- Mode - RTU
- Parity - Even
- Stop Bits - 1
- Baud Rate - 9600

Be aware that 884 models with 4-digit serial numbers have no capability for ASCII mode communications, therefore RTU mode must be used for these models.

Port 2 parameters may be selected using the DIP switches located at the rear of the 884. The top set of switches is used to set the address of the PLC. This number corresponds to the PLC ID# entered in the PLC Name and Port Editor. The address is set as a binary number, where switch 8 is of lowest significance, and switch 1 is of the highest significance.

Dip Switch #	Most Significant				Least Significant			
	1	2	3	4	5	6	7	8
Example: PLC address = 11	0	0	0	0	1	0	1	1

Switch up for a binary 1 (ON); switch down for a binary 0 (OFF)

**Table 34-2 Port 2 DIP Switch Settings**

The bottom set of switches is used to set communication parameters. Be sure the parameters of both the 884 and the PanelMate unit match.

## Micro 84/J375 Modbus Adapter

---

The J375 Modbus Adapter is a communications interface module for the Micro 84 PLC. The J375 provides one RS232C port connection for use with intelligent RS232 devices. Also, port connections are provided for the Micro 84 controller and a P370 Micro 84 Programmer.

The Modbus Adapter provides DIP switches at the rear of its case for address and system parameter selection. The user may select the number of stop bits, parity, and baud rate. Data bits are fixed at 7.

Switch set one (S1) on the J375 determines the station address for the Micro 84. Station addresses are entered as binary numbers, where switch 1 is of lowest significance and switch 8 is of highest significance.

Dip Switch #	Most Significant							Least Significant
	8	7	6	5	4	3	2	1
Example: PLC address = 11	0	0	0	0	1	0	1	1

Switch up for a binary 1 (ON); switch down for a binary 0 (OFF)

**Table 34-3 Port 2 DIP Switch Settings**

Switches 1, 2, 3 and 4 of switch set two (S2) are used to configure the baud rate for the J375. Switches 5 and 6 are used to configure the parity for the J375.

**Note** When communicating with the PanelMate unit using ASCII Modbus, the parity selected must be ODD or EVEN.

Switch 7 of switch set two (S2) is used to select the number of stop bits for the J375. With switch 7 set ON, two stop bits are selected. With switch 7 set OFF, one stop bit is selected.

Switch 8 of switch set two (S2) selects ASCII mode when it is OFF, or RTU mode when it is ON.

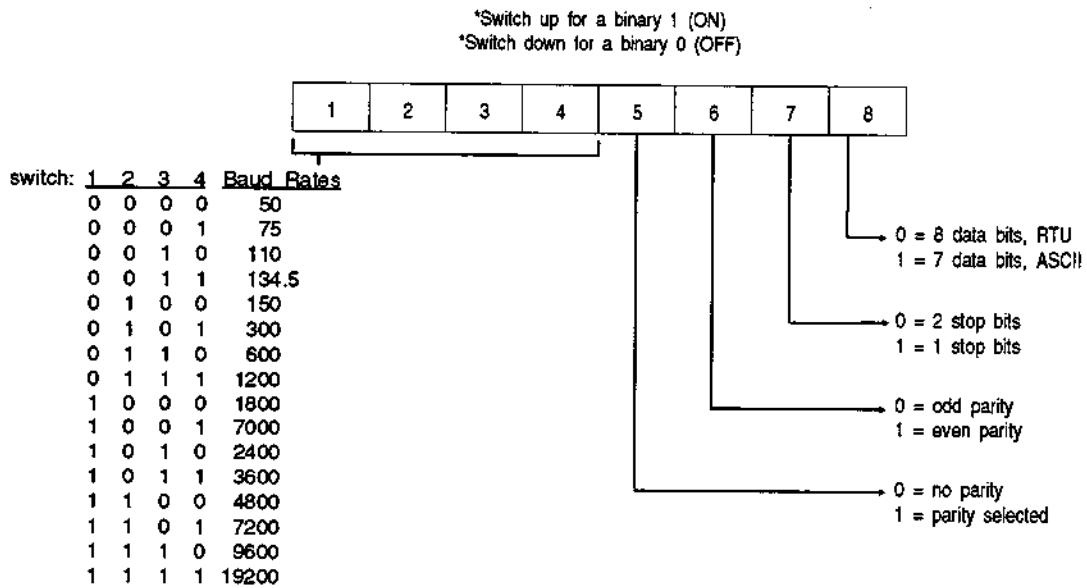


Figure 34-5 Switch Set 2 DIP Switch Settings

## 484 PLC/J474 Modbus Communication Interface

The J474 Communication Interface allows for a computer or other intelligent devices to communicate to a 484 PLC. The J474 may be connected to the Modbus or an RS232 device via a single 30-pin connector. All user options such as baud rate, parity, and stop bits are selected by the wiring of this connector.

The following tables include pin descriptions and selection options, for the J474 Modbus Communication Interface.

Pin	Function	Pin	Function
1	Protective Ground	16	Binary Address 16
2	Data Transmit	17	Stop Bit Option
3	Data Receive	18	Binary Address 32
4	Ready to Send	19	Parity Type Option
5	Clear to Send	20	Data Terminal Ready
6	Data Set Ready	21	Parity Enable
7	Signal Ground	22	Binary Address 64
8	Binary Address 1	23	Modbus Full Duplex In
9	Baud Rate 1	24	Binary Address 128
10	Binary Address 2	25	Modbus Full Duplex Out
11	Baud Rate 2	26	Signal Ground
12	Binary Address 4	27	Modbus Data In
13	Baud Rate 4	28	Mode Select 1
14	Binary Address 8	29	Modbus Data Out
15	Baud Rate 8	30	Mode Select 2

Note: Pins 1 through 7 and 20 conform to EIA RS232C specifications.

**Table 34-4 Port Pinouts for the J474 Interface**

Baud rate is selected by connecting pins 9, 11, 13 and 15 to signal ground at pin 7. The following chart summarizes selection options, where YES = connect to pin 7 and NO = leave unconnected.

Baud Rate	Pin 9	Pin 11	Pin 13	Pin 15
50	YES	YES	YES	YES
75	NO	YES	YES	YES
110	YES	NO	YES	YES
134.5	NO	NO	YES	YES
150	YES	YES	NO	YES
300	NO	YES	NO	YES
600	YES	NO	NO	YES
1200	NO	NO	NO	YES
1800	YES	YES	YES	NO
2000	NO	YES	YES	NO
2400	YES	NO	YES	NO
3600	NO	NO	YES	NO
4800	YES	YES	NO	NO
7200	NO	YES	NO	NO
9600	YES	NO	NO	NO
19200	NO	NO	NO	NO

**Table 34-5 Baud Rate Selection for the J474 Interface**

The slave address (PLC ID#) is selected by connecting pins 24, 22, 18, 16, 14, 12, 10 and 8 to signal ground at pin 26. A binary pattern is used, where zero bit = connect to pin 26 and a one bit = leave unconnected. For example, the address 11 in binary is 00001011, which requires connection of pins 24, 22, 18, 16, and 12 to pin 26, as shown below.

Pin Number	Most Significant						Least Significant	
	24	22	18	16	14	12	10	8
Example: Address = 11	0	0	0	0	1	0	1	1

Switch up for a binary 1 (ON); switch down for a binary 0 (OFF)

**Table 34-6 Example for a Slave Address of 11**

Specific modes of operation are selected by connecting pins 28 and 30 to signal ground at pin 26. The following chart summarizes selection options where YES = connect to pin 26 and NO = leave unconnected.

Mode	Pin 28	Pin 30
ASCII	YES	YES
RTU	YES	NO
Not Valid	NO	YES
Test	NO	NO

**Table 34-7 Mode Selection**

The number of stop bits and parity are selected by connecting pins 17, 19 and 21 to signal ground at pin 7. The following chart summarizes selection options where YES = connect to pin 7 and NO = leave unconnected.

Option	Pin 17	Pin 19	Pin 21
Two stop bits, no parity	YES	YES	YES
One stop bit, no parity	NO	YES	YES
Two stop bits, no parity	YES	NO	YES
One stop bit, no parity	NO	NO	YES
Two stop bits, odd parity	YES	YES	NO
One stop bit, odd parity	NO	YES	NO
Two stop bits, even parity	YES	NO	NO
One stop bit, even parity	NO	NO	NO

**Table 34-8 Stop Bit and Parity Selection**

## Modicon Word and Bit References

---

The following section describes the use of Modicon word and bit references in your configuration. The general word referencing method is:

[plcname,word#format]

The "plcname" is the name of the designated PLC as listed in the PLC Name and Port table. The "word" is the reference number (address) of the word or register to be read or written. The "#format" is a code which specifies the format of the data being read or written. The "plcname" and "#format" are optional.

The general bit referencing method is:

[plcname,bit]

The "plcname" is the designated PLC as listed in the PLC Name and Port table. The "bit" is the reference number (address) of the bit, coil, or input to be written or read.

See chapter 10 for a more detailed explanation of word and bit references, including format descriptions.

## **Modicon Micro 84, 184, 384 and 484**

---

The Modicon PLCs listed above use decimal addresses. The PanelMate unit format default is BIN3. The following list contains the supported memory types.

- 0XXX Coils/discrete outputs
- 1XXX Discrete inputs (read only)
- 3XXX Input registers (read only)
- 4XXX Holding/output registers

The following is the format for a register reference.

[rr]

rr = PLC reference number of the register.

The following is the format for an input reference.

[ii]

ii = PLC reference number for an input.

The following is the format for a coil reference.

[cc]

cc = PLC reference number for a coil.

The PanelMate unit cannot write to inputs or input registers. Therefore, all control button PLC bit references in the PanelMate unit editors refer to Modicon coils.

Bit references in expressions refer to Modicon coils or inputs.

All references to words refer to Modicon registers.

Modicon PLC model Micro84 can read up to 16 words per read cycle. Models 184 and 484 will allow a maximum of 25 contiguous words per read. The maximum number of unused words for the three above mentioned PLCs is 10. The PanelMate unit generates another read when more than 10 unused PLC words are encountered.

## **Modicon 584, 884 and 984 Register, Input and Coil References**

The Modicon PLCs listed above use decimal word addresses. The PanelMate unit format default is BIN4. The following list contains the supported memory types.

0XXXX Coils/discrete outputs  
0XXXXX

1XXXX Discrete inputs (read only)  
1XXXXX

3XXXX Input registers (read only)  
3XXXXX

4XXXX Holding/output registers  
4XXXXX

**Note** The Modicon PLC model 984-785 allows six-digit addressing.  
The maximum address for 984-785 coil/discrete outputs is 065504.  
The maximum address for 984-785 discrete inputs is 165504.  
The maximum address for 984-785 input registers is 364992.  
The maximum address for 984-785 holding/output registers is 457766.

**Note** Bits within holding/output registers are read only.

The following is the format for a register reference.

[rr]

rr = PLC reference number of the register.

The following is the format for an input reference.

[ii]

ii = PLC reference number for an input.

The following is the format for a coil reference.

[cc]

cc = PLC reference number for a coil.

The following is the format for a register bit reference.

[rr bb]

rr = PLC reference number of the register.

bb = PLC reference number of the bit position. The bit positions are numbered from 1 to 16, least significant to most significant, respectively

Note that leading 0's are not required.

**Note** The register number must be followed by a space.

The PanelMate unit cannot write to inputs or input registers. Therefore, all control button PLC bit references in the PanelMate editors refer to Modicon coils.

Bit references in expressions refer to Modicon coils or inputs.

All references to words refer to Modicon registers.

The Modicon PLC models 584, 884 and 984 allow up to 25 contiguous words per single read. The maximum number of unused words is 10. The PanelMate unit generates another read when more than 10 unused PLC words are encountered.

### Examples

The following are examples of valid PLC references which may be assigned in the PanelMate expression fields.

#### Word References

<u>Reference</u>	<u>Description</u>
[40010]	Output register 40010
[30001]	Input register 30001
[401000]	Output register 401000

#### Bit References

<u>Reference</u>	<u>Description</u>
[25]	Coil 25
[10009]	Discrete input 10009
[40098 16]	Bit 1 of output register 40098

## Access Permitted by Maintenance Template

The Maintenance Template will access all memory locations supported by the PLC driver as defined in this chapter. When running online, you may change the PLC reference. Once a new reference is entered, the Maintenance Template will remain in a paused state until the control button labeled "Start Monitor" is depressed. The PanelMate Series 1000 will then parse the reference. (Parsing means checking the syntax and range of the reference to ensure that it is supported by the driver.) If correct, the template begins updating.

**Note** A double word reference (ID, QD, MD, or SMD) should not be entered as the default reference in the Maintenance template.





# Chapter 35

## Omron PLCs

---

The PanelMate Series 1000 can be used with programmable controllers in the Omron C Series (C20K, C28K, C40K, C60K, C20, C20H, C28H, C40H, C200H, C120, C500, C1000H, and C2000H) and the CV Series (CV500 and CV1000).

# Memory

---

The following list contains the memory types supported by the Omron C Series driver.

IR	I/O and Internal Relay
HR	Holding Relay
TC	Timer/Counter
DM	Data Memory
LR	Link Relay
AR	Auxiliary Relay

The following list contains the memory types supported by the Omron CV Series driver.

CIO	I/O and Internal Relay
AR	Auxiliary Relay
TC	Timer/Counter
DM	Data Memory

The Host Link protocol (C-mode and CV-mode) is common to all Omron PLCs. Host Link protocol does not directly support bit writes, although the protocol will allow devices to force bits on and off. The Omron driver has been implemented to force bits on and off. When at power up, the ladder logic in the PLC should write zeroes to all of the bit areas addressed by the PanelMate unit for control buttons. This will ensure that in the event that power is lost to the PLC during the time a control button is pressed, all of the bit areas are returned to a zero state. The IR and LR memory types are not retentive, except for the C200H. After power is lost, control over these areas returns to the PLC ladder logic program. The C200H processor is different from all of the other C and CV CPUs because it has the ability to set whether or not these bit areas are retentive. The C200H should be set up to be non-retentive for these bit areas. A bit in the special relay memory determines whether or not memory is retentive. The PanelMate unit cannot write to special relay memory. You must use your programmer to access special relay memory.

**Note** Omron markets the P series models (C20P, C28P, C40P, and C60P) and the F series models (C120F and C500F) overseas. The P series can be configured like the K series models (C20K, C28K, C40K, and C60K) and the F series can be configured like the C120 and C500 models.

The maximum address range (in decimal) for each of the supported PLC models is given in the following tables.

<u>Model</u>	<u>Range</u>
C20K, C28K, C40K, C60K, C20	IR00-IR19 (IR18-IR19 are read only)
C20H, C28H, C40H, C200H	IR00-IR255 (IR236-IR255 are read only)
C120, C500	IR00-IR63 (IR60-IR63 are read only)
C1000H	IR00-IR255 (IR247-IR255 are read only)
C2000H	IR00-IR255 (IR247-IR255 are read only)
CV500	CIO0000-CIO2555
CV1000	CIO0000-CIO2555

**Table 35-1 I/O and Internal Relay (C-Mode) and CIO (CV-Mode) Memory Ranges**

**Note** The I/O and internal relay (IR) read only memory references shown above are identical to special relay (SR) memory references.

<u>Model</u>	<u>Range</u>
C20K, C28K, C40K, C60K, C20	HR0-HR9
C20H, C28H, C40H, C200H	HR00-HR99
C120, C500	HR00-HR31
C1000H	HR00-HR99
C2000H	HR00-HR99
CV500	Not Supported
CV1000	Not Supported

**Table 35-2 Holding Relay Memory Ranges**

<u>Model</u>	<u>Range</u>
C20K, C28K, C40K, C60K, C20	Not Supported
C20H, C28H, C40H, C200H	AR00-AR27
C120, C500	Not Supported
C1000H	AR00-AR27
C2000H	AR00-AR27
CV500	AR000-AR511
CV1000	AR000-AR511

**Table 35-3 Auxilliary Relay Memory Ranges**

**Note** Auxilliary relay registers are read only.

<u>Model</u>	<u>Range</u>
C20K, C28K, C40K, C60K, C20	Not Supported
C20H, C28H, C40H, C200H	LR00-LR63
C120, C500	LR00-LR31
C1000H	LR00-LR63
C2000H	LR00-LR63
CV500	Not Supported
CV1000	Not Supported

**Table 35-4 Link Relay Memory Ranges**

**Note** Link relay registers are read only.

<u>Model</u>	<u>Range</u>
C20K, C28K, C40K, C60K, C20	TC00-TC47
C20H, C28H, C40H, C200H	TC000-TC511
C120, C500	TC000-TC127
C1000H	TC000-TC511
C2000H	TC000-TC511
CV500	TC0000-TC0511; TC2048-TC2559
CV1000	TC0000-TC1023; TC2048-TC3071

**Table 35-5 Timer and Counter Memory Ranges**

**Note** Timer registers are read only.

<u>Model</u>	<u>Range</u>
C20K, C28K, C40K, C60K	DM00-DM63
C20	Not Supported
C20H, C28H, C40H, C200H	DM0000-DM1999
C120, C500	DM000-DM511
C1000H	DM0000-DM4095
C2000H	DM0000-DM6655
CV500	DM0000-DM8191
CV1000	DM0000-DM9999

**Table 35-6 Data Memory Ranges**

# Possible Configurations

---

The following sections describe some of the possible configurations of the PanelMate unit with the Omron PLCs. Network to network communication is not supported by the Cutler-Hammer IDT Omron driver. The Omron processor models, which do not contain a Host Link port, must use an additional module.

## Direct

---

Direct connection between the PanelMate unit and the processor.

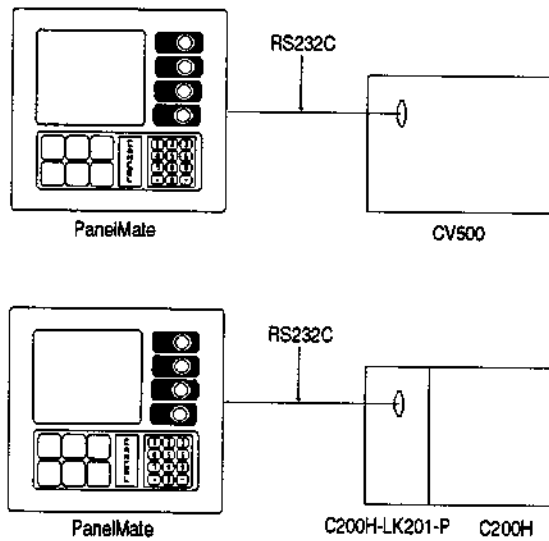


Figure 35-1 Direct Connection

## Network

The following figure shows a network consisting of three PLCs and a PanelMate unit.

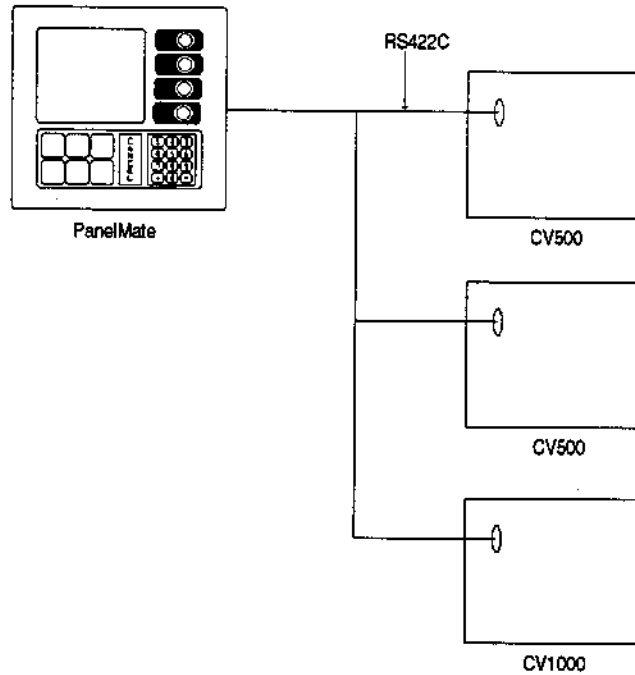


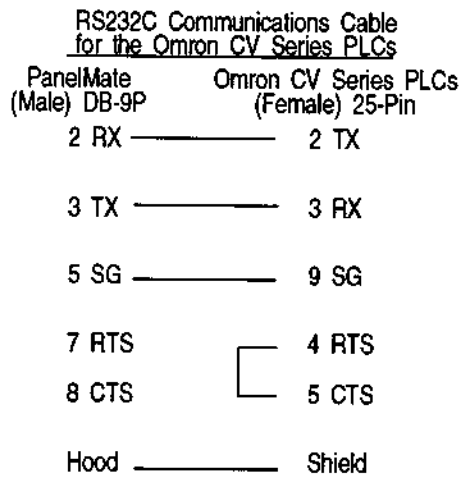
Figure 35-2 Network Connection

## Cabling

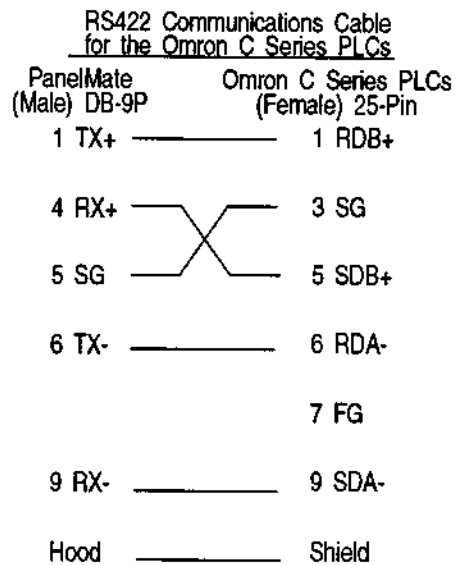
The following tables show the pinouts for the Omron C Series and CV Series PLCs. The Omron driver supports RS232C and RS422 communications. The maximum cable length when using RS232 is 50 feet, while the maximum cable length for RS422 is 4000 feet. RS422 cable must be a twisted double-wire shielded cable. All PanelMate unit ports are female 9-pin (DB-9S), so the connectors on the cables must be male 9-pin (DB-9P).

RS232C Communications Cable for the Omron C Series PLCs		
PanelMate (Male) DB-9P		Omron C Series PLCs (Female) 25-Pin
2 RX	—————	2 TX
3 TX	—————	3 RX
5 SG	—————	7 SG
7 RTS		4 RTS
8 CTS	┌	5 CTS
Hood	—————	Shield

Figure 35-3 RS232C Cabling for the Omron C Series



**Figure 35-4 RS232C Cabling for the Omron CV Series**



**Figure 35-5 RS422 Cabling for the Omron C Series**

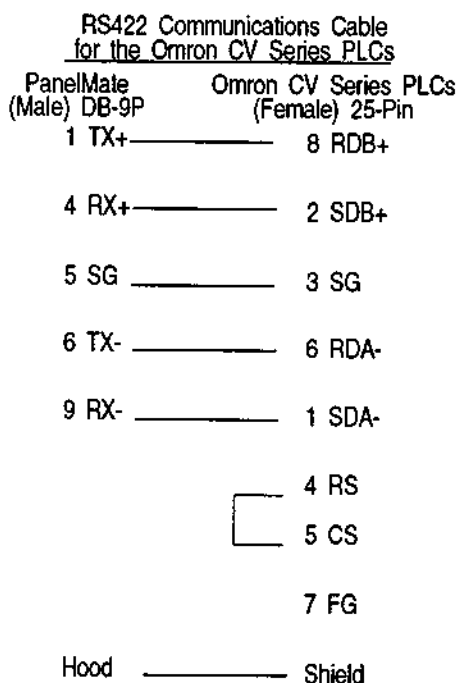


Figure 35-6 RS422 Cabling for the Omron CV Series

## Communications Parameters

---

The Host Link Protocol supports both point-to-point and network interfaces. Both rack-mounted and CPU-mounted Host Link protocol interface links support RS232 and RS422 communication. The default communications parameters are shown below.

Baud rate	300 to 19200
Data bits	7
Parity	Even
Stop bits	2

The Omron PLC ID must be set in the range 0-31 for communications.

**Note** The settings for parameters, such as baud rate, must match the parameters set for the PanelMate unit.

## Communication Module

The C200H-LK201-P communication module is an interface between the PanelMate unit and the Omron PLC. If you have another communication module, refer to your PLC user manual for more information.

**Note** A switch of the same name sometimes has different functions on different units.

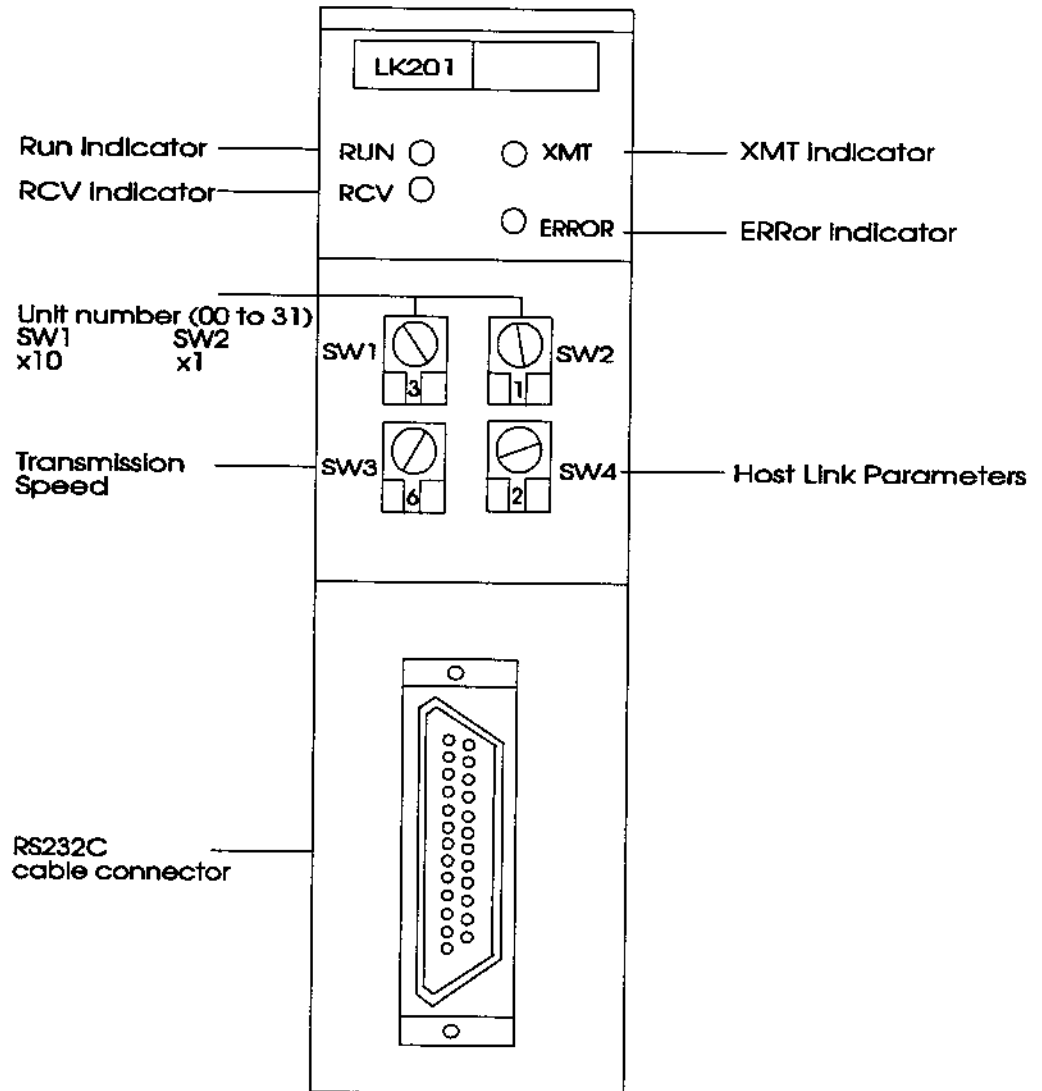


Figure 35-7 C200H-LK201-P Module

SW1 and SW2 sets the unit number. Set SW1 to the number for the tens digit in the unit number and set SW2 to the ones digit in the node or unit number. For configuration information for SW3 and SW4, refer to tables 35-7 and 35-8.

0	300 bps
1	600 bps
2	1200 bps
3	2400 bps
4	4800 bps
5	9600 bps
6	19200 bps
7	Do not set
8	Do not set
9	Do not set

**Table 35-7 Settings for SW3**

The PanelMate unit supports all three command levels (1 through 3) of Host Link Unit commands.

SW4	Command Level	Parity	Transmission Code
0	1	Even	ASCII 7 bit 2 Stop bits
1	1, 2		
2	1, 2, 3		
3	Do not set		
4	1	Odd	
5	1, 2		
6	1, 2, 3		
7	Do not set		
8	1	Even	JIS 8 bits 1 Stop bit
9	1, 2		
A	1, 2, 3		
B	Do not set		
C	1	Odd	
D	1, 2		
E	1, 2, 3		
F	Do not set		

**Table 35-8 Settings for SW4**

The C200H-LK201 communication module has four dipswitches and a selector switch located on the back of the module.

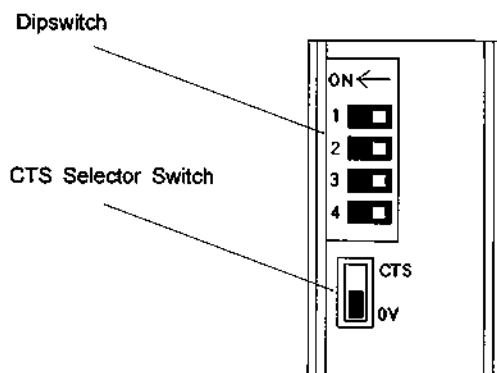


Figure 35-8 C200H-LK01 Communication Module (Rear View)

Dipswitches 1 and 2 are not used and should be set to OFF. Dipswitch 3 configures the module for a single-link or multiple-link and should be set to ON to communicate to the PanelMate unit. Dipswitch 4 configures the 5 V power supply and you should set as necessary for your application.

The CTS Selector Switch must be set to 0V to communicate to the PanelMate unit.

## Omron Word and Bit References

---

The following section describes the use of Omron word and bit references in your configuration. The general word referencing method is:

[plcname,word#format]

The "plcname" is the name of the designated PLC as listed in the PLC Name and Port Table. The "word" is the reference number (address) of the word or register to be read or written. The "#format" is a code which specifies the format of the data being read or written. The "plcname" and "#format" are optional.

The general bit referencing method is:

[plcname,word.bit]

The "plcname" is the designated PLC as listed in the PLC Name and Port Table. The "word" is the reference number (address) of the bit, coil, or input to be written or read. The "bit" number is the bit number in the address.

See chapter 10 for a more detailed explanation of word and bit references, including format descriptions.

The Omron Host Link protocol is supported on the PanelMate unit for models C20K, C28K, C40K, C60K, C20, C20H, C28H, C40H, C200H, C120, C500, C1000H, C2000H, CV500, and CV1000. These models use decimal register addresses. Bit references are from 0 to 15. The PanelMate unit's format default is S16.

Note that the PLC reference consists of two- and three-character prefixes which identifies the memory type being referenced followed by the specific address. The following list contains the memory types supported by the Omron C Series driver.

IR	I/O and Internal Relay
HR	Holding Relay
TC	Timer/Counter
DM	Data Memory
LR	Link Relay
AR	Auxiliary Relay

The following list contains the memory types supported by the Omron CV Series driver.

CIO	I/O and Internal Relay
AR	Auxiliary Relay
TC	Timer/Counter
DM	Data Memory

The following is the format of a register reference.

[plcname, wwnnn]

plcname	Optional PLC name found in the PLC Name Table. If left blank, the default name is used.
,	Optional PLC name delimiter.
ww	The word device memory type.
nnnn	The word number; maximum of 4 characters; leading zeroes are allowed.

The following is the format of a register bit reference.

[plcname, wwnnn.bb]

plcname	Optional PLC name found in the PLC Name Table. If left blank, the default name is used.
,	Optional PLC name delimiter.
ww	The word device memory type.
nnnn	The word number; maximum of 4 characters; leading zeroes are allowed.
.	Bit delimiter character.
bb	Bit number in the range 00-15; leading zeroes are allowed.

The PanelMate unit will allow the Omron models a maximum of 29 contiguous words for each block read. The maximum number of unused words before another read is generated is 15.

## Examples

The following are examples of valid PLC references which may be assigned in the PanelMate unit's expression fields.

**Note** IR and CIO reference internal relay memory. IR is used to reference internal relay memory for the C Series. CIO is used to reference internal relay memory for the CV Series.

### Word References

<u>Reference</u>	<u>Description</u>
[IR013]	Word 13 is referenced in internal relay memory
[HR022]	Word 22 is referenced in holding relay memory
[TC123]	Word 123 is referenced in timer and counter memory
[DM50]	Word 50 is referenced in data memory
[CIO003]	Word 3 is referenced in internal relay memory

### Bit References

<u>Reference</u>	<u>Description</u>
[IR032.14]	Word 32 bit 14 is referenced in internal relay memory
[HR096.3]	Word 96 bit 3 is referenced in holding relay memory
[CIO005.2]	Word 5 bit 2 is referenced in internal relay memory

## Access Permitted by Maintenance Template

The Maintenance Template will access all memory locations supported by the PLC driver as defined in this chapter. When running online, you may change the PLC reference. The Maintenance Template is designed to assist you in specifying the PLC reference by scrolling through a list of mnemonics which are used to enter the PLC word reference. When online in the PLC reference change mode, the following list is available.

"IR", "HR", "AR", "LR", "TC", "DM", and "CIO"

You must enter the correct mnemonics and numeric values and create a legal reference to change a PLC reference. Once a new reference is entered, the Maintenance Template will remain in a paused state until the control button labeled "Start Monitor" is depressed. The PanelMate Series 1000 will then parse the reference. (Parsing means checking the syntax and range of the reference to ensure that it is supported by the driver.) If correct, the template begins updating.







# Chapter 36

## Reliance AutoMate PLCs

---

The PanelMate Series 1000 can be used with any of the programmable controllers in the current Reliance AutoMate family using the Reliance driver. (The PanelMate Series does not support the earlier AutoMate 35 PLC.)

The driver takes responsibility for communications to the programmable controller, generating the protocol necessary to request information from, and send information to the PLC. No ladder logic is required in the PLC to support the interface to the PanelMate unit.

The PanelMate unit supports three types of connections to Reliance PLCs:

- To the R-Net using a Gateway
- To the serial communications card
- Direct to the PLC processor programming port

All three types of connections use the same cable type and the "node.slot" format for the PanelMate unit's PLC ID#.

Each PLC is addressed by a node number and a slot number. This address is entered in the PanelMate unit as the PLC ID# in the PLC Name and Port Table using the format "node.slot" (e.g., 22.3). The period is required. The node and slot number to use depends on the type of connection being used to access the PLC. This is explained in greater detail in the sections that follow. The slot number is simply the slot in which the processor card being addressed resides. Be aware that, in an AutoMate system using a 3-slot power supply, slot 1 is not available.

The PanelMate unit's network ID# should always be set to zero.

When using the CRT or Mini Programmer to configure the PLC, check for the following:

Selection:	1
Node #:	(This is the PLC ID#)
Max Node:	(Should always be one greater than Node #)
Configuration:	0

# Memory

This table shows the maximum amount of memory available for the specific Reliance model. Your PLC may or may not have the maximum amount of memory.

Reliance Model	Valid Bit Ranges		Valid Register Ranges	
	Low	High	Low	High
15	0.00	15.17	0 1000	15 1067
15E	0.00	77.17	0 2000	77 2777
20	0.00	77.17	0 2000	77 2777
20E	0.00	77.17	0 2000 20000	77 3577 23777
30/30E	0.00 2000.00 20000.00	77.17 3777.17 27777.17	0 2000 20000	77 3777 27777
40	0.00 1600.00 20000.00	177.17 17777.17 157775.17	0 1600 20000	177 17777 157775
40X	0.00 1600.00 20000.00	177.17 17777.17 157775.17	0 1600 20000	177 17777 157775
40E	0.00 20000.00	17777.17 157775.17	0 20000	17777 157775

**Table 36-1 Memory Ranges**

**Note** For Reliance Model 15E, registers 76-77 and 2700-2777 are read only.  
 For Reliance Model 20, registers 76-77 are read only.  
 For Reliance Model 20E, registers 76-77 and 2700-2777 are read only.  
 For Reliance Model 30/30E, registers 76-77 and 3700-3777 are read only.  
 For Reliance Model 40/40E/40X, registers 1776-1777 and 17500-17777 are read only.

**Note** For Reliance Models 40 and 40X, if references 1760-1777 are used in your configuration, then references 2000-2015 should not be used. A PLC block read cannot span the boundary from 1777-2000.

# Possible Configurations

---

Examples of possible configurations are described and shown in the following pages.

## Direct

---

The RS232 port on the PLC may be used to make a direct connection to the processor. The processor port has a fixed baud rate of 9600. (A few AutoMate 20 PLCs have a 9600/1200 option.) The PLC node number is set through the programming port using a programming terminal, and is stored in non-volatile memory. Since communications is direct, the slot designation is always zero.

Example:

Processor ID# = 5

PanelMate PLC ID# = 5.0

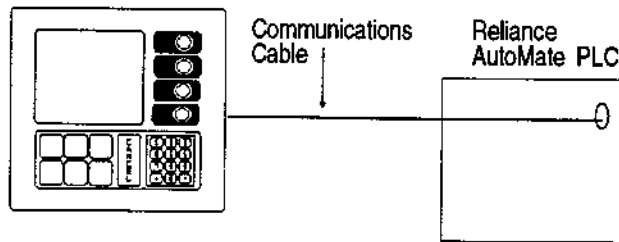
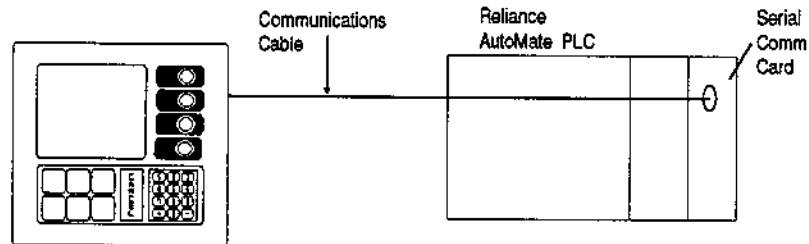


Figure 36-1 Direct Connection

A PanelMate unit connected directly to the programming port of an AutoMate 20 PLC should be deactivated before starting up the PLC. This model PLC stops if it receives a command from the programming port in the first few seconds after starting up. The PanelMate unit may be deactivated by either disconnecting the cable from the programming port or by putting the PanelMate unit in offline mode.

## Serial Communications Card

A serial communication card may be placed in a rack with one or more Reliance PLC processors. The default PLC ID# for the serial communication card on the PanelMate unit will be in the form of "node.slot", where the node number is the slot where the serial communication card resides, and the slot number is the slot where the processor resides. The default baud rates on the top, middle and bottom port on the card are 9600, 4800 and 1200, respectively. Both the node number and the baud rates on the serial communications card can be changed by either PLC logic or by using a programming terminal.



**Figure 36-3 Serial Card Connection**

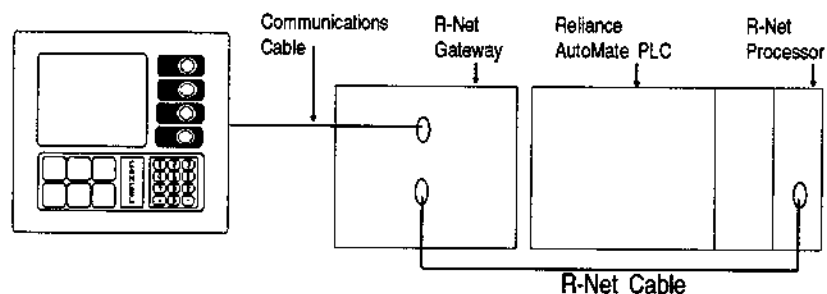
Example:

Serial communications card in slot 2; processor in slot 1.

PanelMate PLC ID# = 2.1

R-Net is the network used by Reliance for its PLCs. To access the network, the PanelMate unit must have a port connected to a Gateway. The Gateway must, in turn, be connected to an R-Net processor. Refer to the Reliance documentation for details on these devices and their connections. The PanelMate unit will have access to every node in the network to which the R-Net processor is connected.

To access a particular PLC in the network, use the node number of the R-Net processor residing in the same rack as the PLC. The node number of the R-Net processor is determined by the switch settings on the front panel of the R-Net processor. The node number is given in hexadecimal on the front panel.



**Figure 36-2 R-Net Connection**

# Cabling

---

The communication between the PanelMate unit and Reliance AutoMate PLCs is RS232C, and has a recommended maximum cable length of 50 cable feet. You should construct a PanelMate unit communication cable of the desired length for each connection. The PanelMate unit is a female 9-pin (DB-9S) port and the Reliance AutoMate port is a female 25-pin (DB-25S). All PanelMate unit ports are female 9-pin (DB-9S), so the connectors on the cables must be male 9-pin (DB-9P).

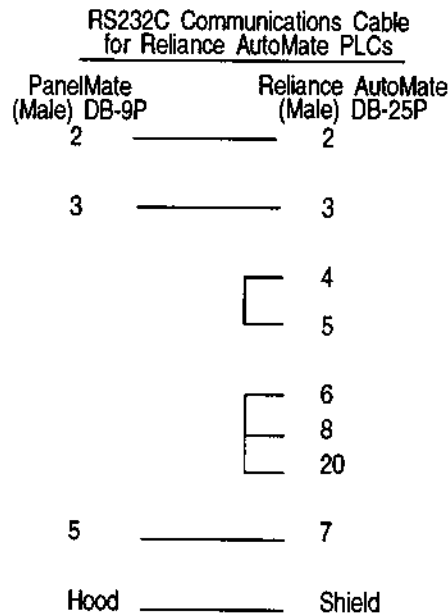


Figure 36-4 RS232C Cabling for Reliance PLCs

# Communications Parameters

---

The standard communications parameters for communicating with Reliance AutoMate PLCs are:

- 8 Data bits
- 1 Stop bit
- No Parity
- 9600 Baud

## Serial Communications Card

---

This card must be set to the correct baud rate unless you use the default value on one of the three ports (9600, 4800, 1200). The card uses its slot number as its node number by default. Both the default baud rate and the node number may be changed either by changing it in a program in the PLC or by means of a programming terminal.

## R-Net Gateway

---

The port parameters may be set on the Gateway using the switches located inside the module. The following figure shows the DIP switch locations.

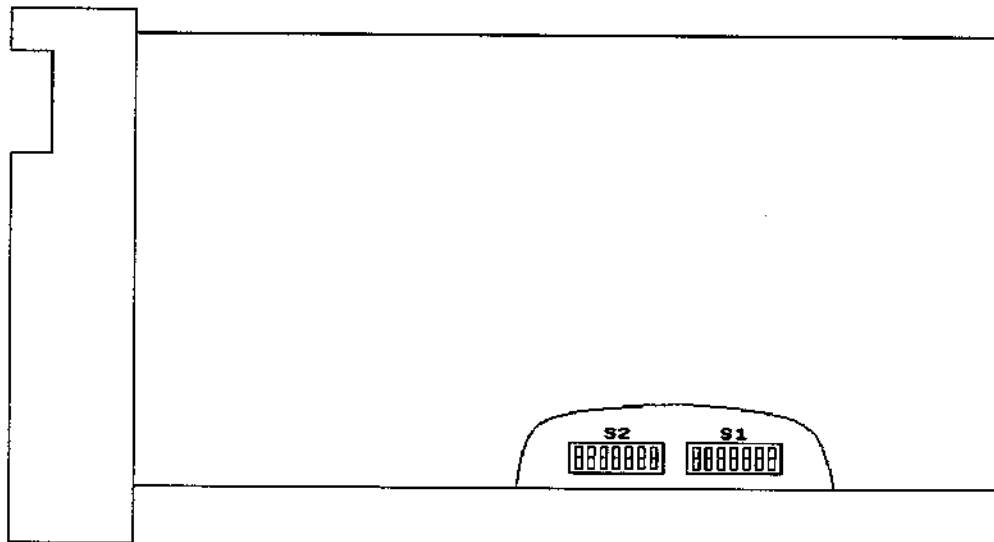


Figure 36-5 Gateway Switch Locations

The Gateway must be connected to an R-Net Processor. This processor must be set to a unique node number. To do this, set the node number using the rotary switches on the front panel of the processor. Remember that the node number is entered here in hexadecimal. The upper rotary switch is used for the high-order digit and the lower switch for the low-order digit.

Switch Position	On	Off
S1-1	Illegal	Asynchronous*
S1-2	Illegal	Binary*
S1-3	8 Data bits*	7 Data bits
S1-4	Parity on	Parity off*
S1-5	Parity even	Parity odd*

\* Default value

**Table 36-2 Port Configuration**

Baud Rate	S1-6	S1-7	S1-8
110	Off	Off	Off
300	On	Off	Off
600	Off	On	Off
1200	On	On	Off
2400	Off	Off	On
4800	On	Off	On
9600*	Off	On	On
19200 (see S2-6)	On	On	On

\* Default value

**Table 36-3 Baud Rate Selection**

Switch Position	Function	On	Off
S2-4	Receive clk		External Internal*
S2-5	I/O Port		RS422 RS232*
S2-6	19200 baud		1937Hz** 18750Hz***
S2-7	Not used		-
S2-8	Not used		-

\* Default value

\*\* +2.8 %

\*\*\* -2.3%

**Table 36-4 Port Configuration**

## Reliance Word and Bit References

---

The following section describes the use of Reliance word and bit references in your configuration. The general word referencing method is:

[plcname,word#format]

The "plcname" is the name of the designated PLC as listed in the PLC Name and Port Table. The "word" is the reference number (address) of the word or register to be read or written. The "#format" is a code which specifies the format of the data being read or written. The "plcname" and "#format" are optional.

The general bit referencing method is:

[plcname,bit]

The "plcname" is the designated PLC as listed in the PLC Name and Port Table. The "bit" is the reference number (address) of the bit, coil, or input to be written or read.

See chapter 10 for a more detailed explanation of word and bit references, including format descriptions.

Reliance AutoMate PLCs use octal register addresses. The PanelMate unit format default is S16.

The following is the format for a register reference:

[rr]

rr                    PLC reference number of the register.

The following is the format for a register bit reference:

[rr.bb]

rr                    PLC reference number of the register.

bb                    PLC reference number of the bit.

**Note**    A period (.) must be between the register and bit reference numbers.

The table at the beginning of this chapter shows the maximum amount of memory available for the specific Reliance model. Your PLC may or may not have the maximum amount of memory.

The driver supports a maximum of 60 contiguous words per read. The PanelMate unit generates another read when more than 15 unused PLC words are encountered.

## Examples

The following are examples of valid PLC references which may be assigned in the PanelMate expression fields.

### Word References

Reference	Description
[12]	Word 12 of Reliance Model 15
[2533]	Word 2533 of Reliance Model 20
[21333]	Word 21333 of Reliance Model 30/30E
[163]	Word 163 of Reliance Model 40
[2051]	Word 2051 of Reliance Model 40E

### Bit References

Reference	Description
[2.3]	Word 2 bit 3 of Reliance Model 15
[42.5]	Word 42 bit 5 of Reliance Model 20
[14.6]	Word 14 bit 6 of Reliance Model 30/30E
[4000.16]	Word 4000 bit 16 of Reliance Model 40
[284.7]	Word 284 bit 7 of Reliance Model 40E

## Access Permitted by Maintenance Template

The Maintenance Template will access all memory locations supported by the PLC driver as defined in this chapter. When running online, you may change the PLC reference. Once a new reference is entered, the Maintenance Template will remain in a paused state until the control button labeled "Start Monitor" is depressed. The PanelMate Series 1000 will then parse the reference. (Parsing means checking the syntax and range of the reference to ensure that it is supported by the driver.) If correct, the template begins updating.







# Chapter 37

## Siemens PLCs

---

Using the CP524 or CP525 communications coprocessor, the PanelMate Series 1000 can communicate with any of the Siemens S5 U family of PLCs. The CP524 and CP525 communications coprocessor uses the 3964R protocol. The CP525 has two independent serial ports. The CP524 has only one serial port. (All references to the CP525 will include the CP524 unless otherwise noted.) The driver takes responsibility for communications to this programmable controller, generating the protocol necessary to request information from and send information to the PLC.

Unsoliciteds are not supported and should not be used. When writing to bit or byte addresses that do not exist, no errors will be generated. This section describes the basic configuration of Siemens PLCs and the PanelMate unit.

The Siemens driver supports models S5-115U, S5-135U and S5-155U.

# Memory

The following list contains the memory types supported by the Siemens driver.

D	Data Block
I	Input (Read only)
F	Flag
C	Counter (Read only)
Q	Output
T	Timer (Read only)

**Note** Absolute, System and Extended memory areas are not supported.

There are several rack models within the Siemens S5 family of products. Each rack model can have different CPUs. Each CPU model may have different memory limits. The maximum address value for each of the supported PLC models is given in the following tables.

	CPU 944	CPU 943	CPU 942	CPU 941
Data Block (words)	256	256	256	256
Inputs (bytes)	128	128	128	64
Flags (bytes)	256	256	256	256
Counters (words)	128	128	128	128
Outputs (bytes)	128	128	128	64
Timers (words)	128	128	128	128

**Table 39-1 S5-115U CPU and Memory Configurations**

	CPU 928	CPU 922 (R Processor)	CPU 921 (S Processor)	CPU 920 (M Processor)
Data Blocks (words)	256	256	256	256
Inputs (bytes)	512	512	512	512
Flags (bytes)	256	256	256	-
Counters (words)	256	128	128	-
Outputs (bytes)	512	512	512	512
Timers (words)	256	128	128	-

**Table 39-2 S5-135U CPU and Memory Configurations**

	CPU 946/7	CPU 922 (R Processor)	CPU 921 (S Processor)	CPU 920 (M Processor)
Data Block (words)	256	256	256	256
Inputs (bytes)	512	512	512	512
Flags (bytes)	256	256	256	-
Counters (words)	256	128	128	-
Outputs (bytes)	512	512	512	512
Timers (words)	256	128	128	-

**Table 39-3 S5-155U CPU and Memory Configurations**

**Note** A - indicates that the memory area is not supported by the CPU model.

The S5-135U and S5-155U can operate in a multiprocessor configuration using either the M, S, R processors or CPU 928. These processors can also be used in stand-alone mode in the S5-155U. The following is a brief description of each processor.

CPU928	This processor is designed for multiple tasks: it provides fast binary signal processing (open-loop control) as well as fast word processing (computing and closed-loop control).
M Processor	This processor is used for data processing, arithmetic and statistics.
R Processor	This processor is used mainly for fast word processing (computing and closed-loop control). It can also be used for binary signal processing.
S Processor	This processor is used mainly for fast binary signal processing (open-loop control). It can also be used for computing and closed-loop control.

# Possible Configurations

The following sections describe some of the possible configurations of the PanelMate unit with Siemens PLCs.

## Direct Connection

Direct connection between one PanelMate unit and one Siemens PLC.

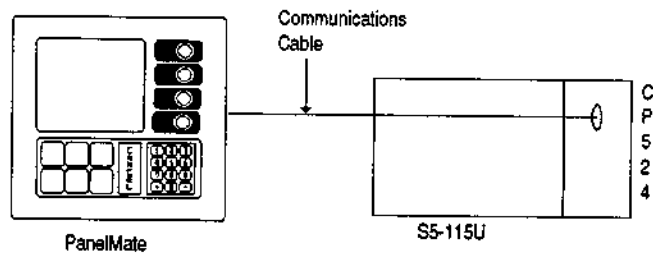


Figure 37-1 Direct Connection

## Multiple Connection

The following figure shows a multiple connection consisting of two PanelMate units and a Siemens PLC.

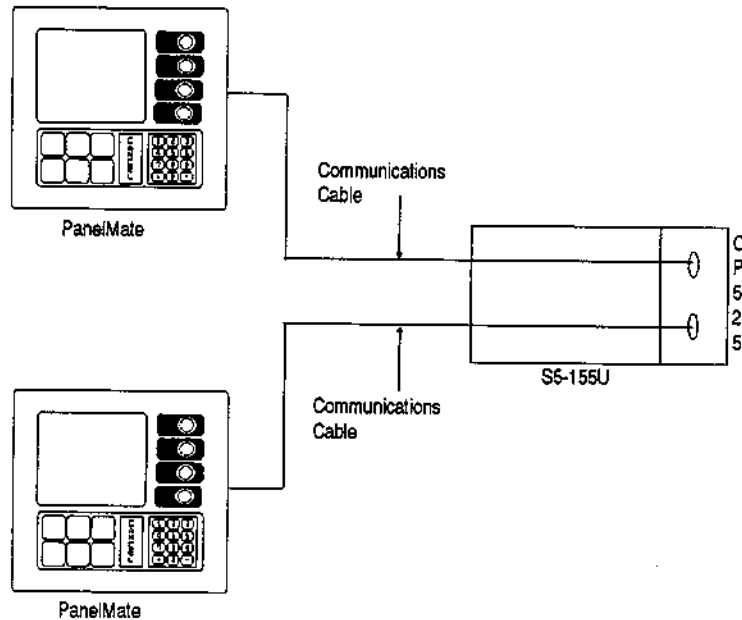


Figure 37-2 Multiple Connection

# Cabling

---

The Siemens driver supports RS232C communications only. The following figure shows the cable configuration between the PanelMate unit and CP524 and CP525.

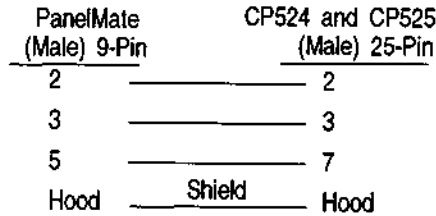


Figure 37-3 PanelMate to Processor Cabling

## Communications Parameters

---

The default communications parameters are shown below. If you intend to use any baud rate other than the default, you must use the Siemens programmer to change it. The data bits, parity, and stop bits must be set as shown below and cannot be changed on the Siemens PLC.

Data bits	8
Parity	Even
Stop bits	1

**Note** The baud rate is configurable to these settings: 19200, 9600, 4800, 2400, 1200, 600, 300 and 110. When using a CP525, the sum of the baud rate on the two serial ports must not exceed 19200. In all cases, configure the PanelMate unit's serial port to match the selected baud rate.

Note that in order for the PanelMate unit and the Siemens PLC to communicate, the Siemens PLC must be set to the higher priority. The Siemens SEND-ALL and RECEIVE-ALL functions must be executing in the CPU.

# Siemens Word, Byte, and Bit References

---

The following section describes the use of Siemens word, byte, and bit references in your configuration. The general word referencing method is:

[plcname,word#format]

The "plcname" is the name of the designated PLC as listed in the PLC Name and Port Table. The "word" is the reference number (address) of the word or register to be read or written. The "#format" is a code which specifies the format of the data being read or written. The "plcname" and "#format" are optional.

The general bit referencing method is:

[plcname,bit]

The "plcname" is the designated PLC as listed in the PLC Name and Port Table. The "bit" is the reference number (address) of the bit, coil, or input to be written or read.

See chapter 10 for a more detailed explanation of word and bit references, including format descriptions.

The Siemens driver supports models S5-115U, S5-135U and S5-155U. These models use decimal register addresses and bit offsets.

Note that there is a one or two-character prefix which identifies the type of variable being referenced followed by the specific number of the variable. The following list contains the memory types supported by the Siemens driver.

C	Counter (Read only)
T	Timer (Read only)
DW	Data Word
FW	Flag Word (Read only)
IW	Input Word (Read only)
QW	Output Word (Read only)
DL	Left Byte in Data Word
DR	Right Byte in Data Word
FY	Flag Byte (Read only)
IB	Input Byte (Read only)
QB	Output Byte (Read only)
D	Data Bit
F	Flag Bit
I	Input Bit (Read only)
Q	Output Bit

The prefixes are used to identify the usage of the variable to the Siemens PLC.

## Word References

The following is the format for a data word memory reference.

[mddd:www]

m	Word memory type symbol (i.e., DW).
ddd	Data block number; 3-digit maximum, leading zeroes allowed.
www	Word offset within data block; 3-digit maximum, leading zeroes allowed.

The following is the format for a word memory reference or a register (16-bit word) reference in timer or counter memory (read only).

[m:www]

m	Word memory type symbol (i.e., IW, FW, QW, T, C).
www	Word, timer, or counter number; 3 digit maximum, leading zeroes allowed. (Input words are read only).

## Byte References

The following is the format for a data byte memory reference.

[mddd:www]

m	Byte memory type symbol (i.e., DL, DR).
ddd	Data block number; 3-digit maximum, leading zeroes allowed.
www	Word number; 3 digit maximum, leading zeroes allowed.

The following is the format for a byte memory reference.

[m:bbb]

m	Byte memory type symbol (i.e., IB, FY, QB).
bbb	Byte number; 3 digit maximum, leading zeroes allowed. (Input bytes are read only).

## Bit References

The following is the format for a data bit reference within a data block.

[mddd:www.t]

m	Byte memory type symbol (i.e., D).
ddd	Data block number; 3-digit maximum, leading zeroes allowed.
www	Byte number; 3 digit maximum, leading zeroes allowed.
t	Bit number; 1 digit maximum.

The following is the format for a bit reference within a byte.

[m:bbb.t]

m	Byte memory type symbol (i.e., I, F, Q).
bbb	Byte number; 3 digit maximum, leading zeroes allowed. (Input bits are read only).
t	Bit number; 1 digit maximum.

Since the 3964R Protocol does not support bit and byte writes, the following is a Bit/Byte Write function block is required. It allows the PanelMate unit to write to data word bits, output bits, flag bits, and data word bytes. The PanelMate unit writes directly to Data Block 230. Data Block 230 must exist in the PLC and be ten words in length.

**Note** If the PLC Bit/Byte Write program uses interrupts which write to flag words 200-210, then these flag words should not be used. A solution would be to increase the size of data block 230 to 21 words and replace the flag word references with the new data block words.

<u>ADDRESS</u>	<u>COMMAND</u>	<u>DESCRIPTION</u>
000B	:	BIT/BYTE WRITE FUNCTION BLOCK.
000C	:	*****
000D	:	
000E	:C DB 230	CALLS DATA BLOCK 230.
000F	:	
0010	:	OUTPUT BIT WRITE ROUTINE.
0011	:	*****
0012	:L KM 00000000 00000000	LOAD MASK INTO ACCUM1.
0014	:L DW 1	GET DW1 (PANELMATE Q BIT WRITES).
0015	:<=F	TEST TO SEE IF BIT WRITE REQUESTED.
0016	:JC =M001	IF BIT WRITE PRESENT .. CONTINUE
0017	:	ELSE JUMP OVER SUBROUTINE.
0018	:	
0019	:T FW 200	TRANSFER DATA TO FW200 (FASTER).
001A	:L KM 00000111 01111111	STRIP ALL BUT BIT # AND ADDRESS
001C	:AW	AND MASK WITH DATA.
001D	:T FW 202	TRANSFER RESULT INTO FW202.
000E	:= F 210.0	RESET THE FIRST OPERATION BIT.
001F	:A F 200.4	CHECK FOR SET/RSET ==> INTO ROL.
0020	:DO FW 202	LOAD BIT AND WORD ADDR OF OUTPUT.
0021	:= Q 0.0	COPY ROL VALUE INTO OUTPUT BIT.
0022	:	
0023	:L KH 0000	ZERO OUT DW1 IN DB230 SO ANOTHER
0025	:T DW 1	BIT WRITE CAN BE PREFORMED.
0026	:	
0027	:	
0028	:	
0029	:	FLAG BIT WRITE ROUTINE.
002A M001	:	*****

<u>ADDRESS</u>	<u>COMMAND</u>	<u>DESCRIPTION</u>
002B	:L KM 00000000 00000000	LOAD MASK INTO ACCUM1.
002D	:L DW 2	GET DW2 (PANELMATE F BIT WRITES).
002E	:<=F	TEST TO SEE IF BIT WRITE REQUESTED.
002F	:JC =M002	IF BIT WRITE PRESENT .. CONTINUE
0030	:	ELSE JUMP OVER SUBROUTINE.
0031	:	
0032	:T FW 200	TRANSFER DATA TO FW200 (FASTER).
0033	:L KM 00000111 11111111	STRIP ALL BUT BIT # AND ADDRESS
0035	:AW	AND MASK WITH DATA.
0036	:T FW 202	TRANSFER RESULT INTO FW202.
0037	:= F 210.0	RESET THE FIRST OPERATION BIT.
0038	:A F 200.4	CHECK FOR SET/RSET ==> INTO ROL.
0039	:DO FW 202	LOAD BIT AND WORD ADDR OF OUTPUT.
003A	:= F 0.0	COPY ROL VALUE INTO FLAG BIT.
003B	:	
003C	:L KH 0000	ZERO OUT DW2 IN DB230 SO ANOTHER
003E	:T DW 2	BIT WRITE CAN BE PREFORMED.
003F	:	
0040	:	
0041	:	
0042	:	DATA BIT WRITE ROUTINE.
0043 M002	:	*****
0044	:L KM 00000000 00000000	LOAD MASK INTO ACCUM1.
0046	:L DW 3	GET DW3 (PANELMATE DATA BIT WRITES).
0047	:<=F	TEST TO SEE IF BIT WRITE REQUESTED.
0048	:JC =M003	IF BIT WRITE PRESENT .. CONTINUE
0049	:	ELSE JUMP OVER SUBROUTINE.
004A	:	
004B	:T FW 200	TRANSFER DATA TO FW200 (FASTER).
004C	:L KM 00001111 11111111	STRIP ALL BUT BIT # AND ADDRESS
004E	:AW	AND MASK WITH DATA.
004F	:T FW 202	TRANSFER RESULT INTO FW202

<u>ADDRESS</u>	<u>COMMAND</u>	<u>DESCRIPTION</u>
0050	:T FW 206	AND FW206.
0051	:DO DW 4	GET THE DB # AND
0052	:C DB 0	CALL THE DB #.
0053	:L FY 202	LOAD BIT AND WORD ADDR.
0054	:L KM 00000000 00000111	LOAD THE MASK TO RETRIEVE THE BIT ADDR.
0056	:>F	IS THE BIT ADDR BETWEEN 0-7.
0057	:JC =M004	IF SO JUMP TO M004 (LO BYTE DATA BIT)
0058	:L KB 209	ELSE SET UP FY207'S LO DATA BIT.
0059	:T FY 207.	
005A	:JU =M005	JUMP OVER HI DATA BIT SETUP.
005B M004	:L KB 208	SET UP FY207'S HI DATA BIT.
005C	:T FY 207	
005D M005	:L FW 202	LOAD BIT AND ADDRESS.
005E	:L KM 00000000 11111111	MASK OUT ADDRESS.
0060	:AW	
0061	:T FW 202	TRANSFER TO FW202 FOR SPEED.
0062	:DO FW 202	SET UP FOR LW TO GET THE DATA WORD.
0063	:L DW 0	LOAD THE DATA WORD INTO ACCUM1.
0064	:T FW 208	TRANSFER THE CURRENT VALUE TO FW208.
0065	:= F 210.0	RESET FIRST OPERATION BIT.
0066	:A F 200.4	CHECK TO SEE IF SET OR RESET IS
0067	:DO FW 206	PERFORMED AND SET OR RESET THE
0068	:= F 0.0	CORRESPONDING BIT.
0069	:L FW 208	LOAD FW W/ BIT CHANGED
006A	:DO FW 202	AND TRANSFER IT BACK TO ITS
006B	:T DW 0	ORIGINAL DW.
006C	:C DB 230	CALL ORIGINAL DATA BLOCK.
006D	:L KH 0000	ZERO OUT DW3 IN DB230 SO ANOTHER
006F	:T DW 3	BIT WRITE CAN BE PERFORMED.
0070	:	
0071	:	
0072	:	
0073	:	DATA BYTE HI WRITE ROUTINE.
0074 M003	:	*****

<u>ADDRESS</u>	<u>COMMAND</u>	<u>DESCRIPTION</u>
0075	:L KM 00000000 00000000	LOAD MASK.
0077	:L DW 6	CHECK TO SEE IF DATA BYTE HI WRITE
0078	:=F	WRITE WAS REQUESTED CONTINUE IF YES
0079	:JC =M006	ELSE JUMP OVER SUBROUTINE.
007A	:L DW 5	LOAD THE DATA BYTE ADDR.
007B	:T FW 200	TRANSFER IT TO FW200 FOR SPEED.
007C	:DO DW 6	SET UP TO CALL THE DB.
007D	:C DB 0	CALL THE DB.
007E	:L FY 201	LOAD THE WORD ADDR.
007F	:T FW 202	SET UP TO LOAD THE DATA WORD.
0080	:DO FW 202	
0081	:L DW 0	LOAD THE DATA WORD.
0082	:L KM 00000000 11111111	MASK OUT THE HI BYTE.
0084	:AW	
0085	:L FY200	LOAD THE DATA BYTE.
0086	:SLW 8	ROTATE IT INTO POSITION.
0087	:OW	MERGE OLD LO AND NEW HI BYTES.
0088	:DO FW 202	TRANSFER THE WORD BACK TO ITS
0089	:T DW 0	ORIGINAL LOCATION.
008A	:C DB 230	CALL BACK DB23.
008B	:L KH 0000	ZERO OUT DW6 IN DB230 SO ANOTHER
008D	:T DW 6	DATA BYTE HI WRITE CAN BE PERFORMED.
008E	:	
008F	:	
0090	:	
0091	:	DATA BYTE LO WRITE ROUTINE.
0092 M006	:	*****
0093	:L KM 00000000 00000000	LOAD MASK.
0095	:L DW 8	CHECK TO SEE IF DATA BYTE LO WRITE
0096	:=F	WRITE WAS REQUESTED CONTINUE IF YES
0097	:JC =M007	ELSE JUMP OVER SUBROUTINE.
0098	:L DW 7	LOAD THE DATA BYTE ADDR.
0099	:T FW 200	TRANSFER IT TO FW200 FOR SPEED.

<u>ADDRESS</u>	<u>COMMAND</u>	<u>DESCRIPTION</u>
009A	:DO DW 8	SET UP TO CALL THE DB.
009B	:C DB 0	CALL THE DB.
009C	:L FY 201	LOAD THE WORD ADDR.
009D	:T FW 202	SET UP TO LOAD THE DATA WORD.
009E	:DO FW 202	
009F	:L DW 0	LOAD THE DATA WORD.
00A0	:L KM 11111111 00000000	MASK OUT THE LO BYTE.
00A2	:AW	
00A3	:L FY 200	LOAD THE DATA BYTE.
00A4	:OW	ROTATE IT INTO POSITION.
00A5	:DO FW 202	MERGE OLD HI AND NEW LO BYTES.
00A6	:T DW 0	TRANSFER THE WORD BACK TO ITS
00A7	:C DB 230	ORIGINAL LOCATION.
00A8	:L KH 0000	CALL BACK DB230.
00AA	:T DW 8	ZERO OUT DW6 IN DB230 SO ANOTHER
00AB M007	:BE	DATA BYTE LO WRITE CAN BE PREFORMED.

## Examples

The following are examples of valid PLC references which may be assigned in the PanelMate expression fields.

### Word References

<u>Reference</u>	<u>Description</u>
[C:3]	Counter 3
[DW13:155]	Data block 13, word 155
[FW:4]	Flag block 4
[IW:46]	Input block 46
[QW:005]	Output block 5
[T:242]	Timer 242

### Byte References

<u>Reference</u>	<u>Description</u>
[DL12:004]	Left byte in data word 4, data block 12
[DR22:192]	Right byte in data word 192, data block 22
[IB:013]	Input byte 13
[FY:251]	Flag byte 15
[QB:245]	Output byte 245

### Bit References

<u>Reference</u>	<u>Description</u>
[D17:32.15]	Data block 17, word 32, bit 15
[F:16.4]	Flag byte 16, bit 4
[I:96.4]	Input byte 96, bit 4
[Q:75.2]	Output byte 75, bit 2

## **Access Permitted by Maintenance Template**

The Maintenance Template will access all memory locations supported by the PLC driver as defined in this chapter. When running online, you may change the PLC reference. The Maintenance Template is designed to assist you in specifying the PLC reference by scrolling through a list of mnemonics which are used to enter the PLC word reference. When online in the PLC reference change mode, the following list is available.

"I", "Q", "F", "D", "T", "C", "DW", "IW", "QW", "FW", "DL",  
"DR", "IB", "QB", "FY" and ":"

You must enter the correct mnemonics and numeric values and create a legal reference to change a PLC reference. Once a new reference is entered, the Maintenance Template will remain in a paused state until the control button labeled "Start Monitor" is depressed. The PanelMate Series 1000 will then parse the reference. (Parsing means checking the syntax and range of the reference to ensure that it is supported by the driver.) If correct, the template begins updating.







# Chapter 38

## Square D PLCs

---

The PanelMate Series 1000 can be used with any of the Square D Sy/Max family of PLCs, using the Square D driver. The driver takes responsibility for communications to this programmable controller, generating the protocol necessary to request information from and send information to the PLC.

This section describes the basic configuration of Square D PLCs and the PanelMate unit. More information on the Square D modules can be found in the appropriate Square D Instruction Bulletin.

The Square D PLC driver supports models 100, 300, 400, 500, 600, and 700. The SY/MAX protocol must be used for each of the above mentioned models. No special ladder logic is required in the PLC to support the interface. Direct connection to the processor and network communications, using the Network Interface Module (NIM), are supported. Write broadcasting is also supported by this driver.

The following Square D route assignments can be used: 00-199 for normal network routing, 200 to read the NIM status, and 233-254 for network broadcasting capabilities.

# Memory

---

The following list contains the memory types supported by the Square D driver.

S	Storage register
R	Internal relay logic
N	External I/O
O	External output
I	External input

The maximum address range for each of the supported PLC models is given in the following table.

<u>Model</u>	<u>Address Range</u>
100	1-44 words
300	1-112 words
400	1-8000 words
500	1-2008 words
600	1-8000 words
700	1-8000 words

Table 38-1 Address Ranges

# Possible Configurations

---

The following sections describe some of the possible configurations of the PanelMate unit with Square D PLCs. Network to network communication is not supported by the Cutler-Hammer IDT Square D driver.

## Direct

---

Direct connection between PanelMate unit and the processor.

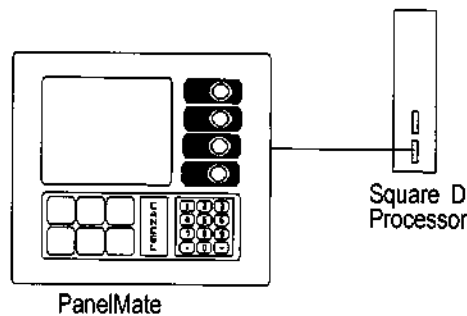


Figure 38-1 Direct Connection

**Note** When using a direct connection between the PanelMate unit and the Square D processor, the minimum baud rate for proper operation is 1200.

## Network

The following figure shows a network consisting of two devices and a PanelMate unit.

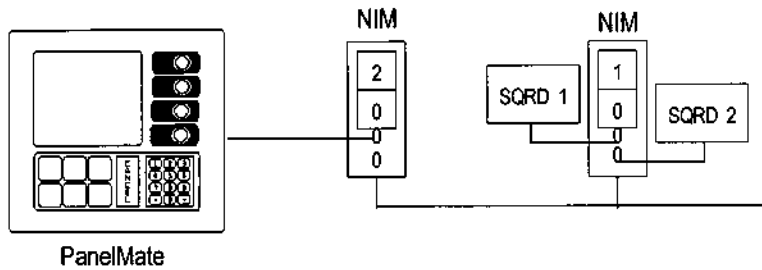
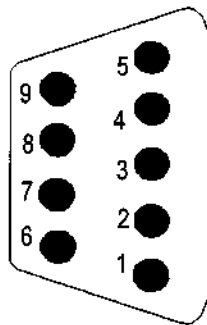


Figure 38-2 Network Connection

**Note** Network reads are not currently supported.

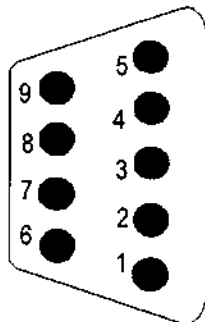
## Cabling

The Square D driver supports RS422 communications only. The following tables show the pinouts for the processor module ports and NIM ports. These pinouts should be used for creating the communications cables.



Pin	Signal
1	RS422 TxD (-)
2	RS422 TxD (+)
3	RS422 RxD (-)
4	RS422 RxD (+)
5	+5 V
6	+5 V
7	Signal GND
8	Signal GND
9	Chassis GND (shield)

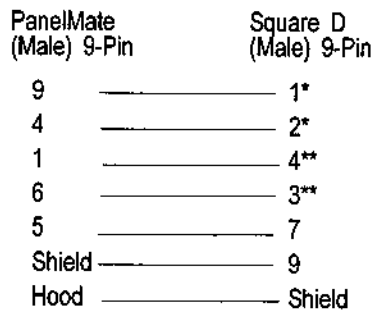
Figure 38-3 Square D Processor Port Pinouts



Pin	Signal
1	RS422 TxD (-)
2	RS422 TxD (+)
3	RS422 RxD (-)
4	RS422 RxD (+)
5	CTS (+)
6	RTS (+)
7	CTS (-)
8	RTS (-)
9	Chassis GND (shield)

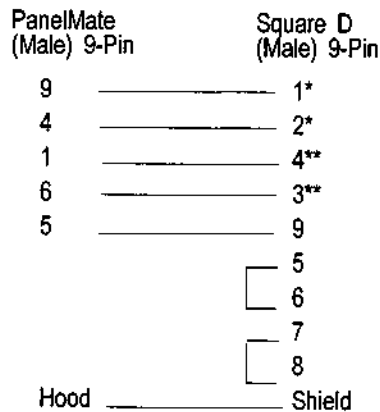
Figure 38-4 Square D NIM Port Pinouts

The following figures show the cable configuration between the PanelMate unit and Square D modules. The maximum cable length when using RS422 is 4000 feet. RS422 cable must be a twisted double-wire shielded cable. All PanelMate unit ports are female 9-pin (DB-9S), so the connectors on the cables must be male 9-pin (DB-9P).



\* Shielded twisted pair  
\*\*Shielded twisted pair

Figure 38-5 PanelMate to Processor Cabling



\* Shielded twisted pair  
\*\*Shielded twisted pair

Figure 38-6 PanelMate to NIM Cabling

## Communications Parameters

The default communications parameters are shown below. If you intend to use any baud rate other than the default with a direct connection, you must use the Square D programmer to change it. The data bits, parity, and stop bits must be set as shown below and cannot be changed on the Square D PLC:

Baud rate	9600
Data bits	8
Parity	Even
Stop bits	1

The NIM is the only part of the network described earlier that has switches which need to be set for proper communications. Two types of switches reside on the NIM; thumbwheel and DIP.

**Note** The settings for parameters, such as baud rate, must match the parameter setting of the PanelMate unit.

## Thumbwheel Switches

The two thumbwheel switches, shown in the following figure, are used to select the module address on the network. The number set on the thumbwheel switches and the port number are used as the Network ID# and the PLC ID# in the PLC Name and Port Editor. The port number is used as a prefix on the front of the number on the thumbwheels.

For example, if the thumbwheels are set to 23 and the Square D processor is connected to COMM port 0 and the PanelMate unit is connected to COMM port 1, the PLC ID# should be 23 and the Network ID# should be 123.

## DIP Switches

The NIM has three DIP switches which are mounted at the rear of the module near the card edge connector. The three DIP switches are labeled S3, S4, and S5. These switches are used to set the network baud rate, COM port baud rate, and mode of operation for COM ports 0 and 1.

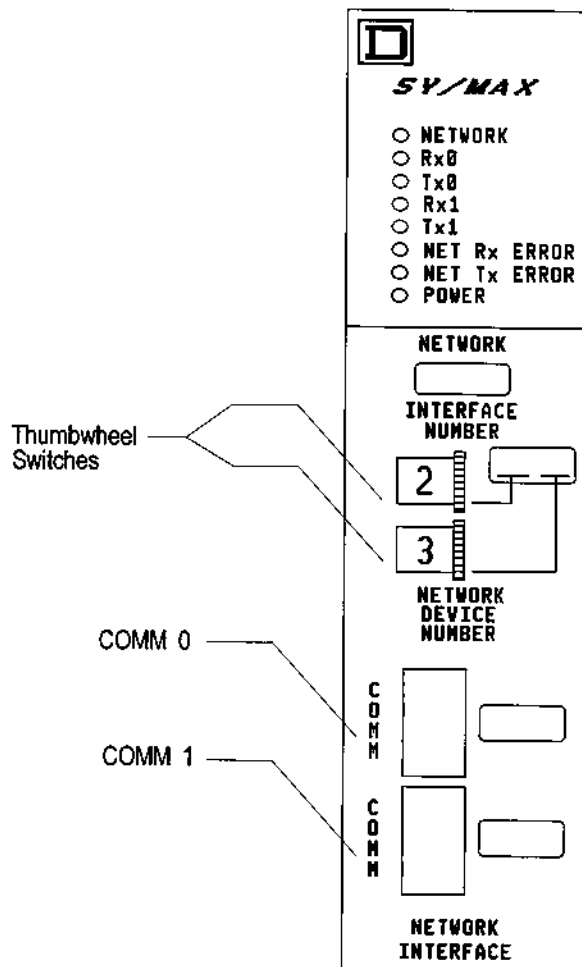


Figure 38-7 NIM

### DIP Switch S3

A special network port, on the bottom of the NIM, is used for high speed network communications. DIP switch S3 selects the network baud rate for network port. The cable length to be used determines the maximum baud rate. The following table shows the maximum cable length for each switch selectable baud rate.

Switch Position				Baud Rate	Max Cable Length (feet)
1	2	3	4		
Open	Closed	Closed	Closed	500,000	2,400
Closed	Open	Closed	Closed	250,000	4,250
Closed	Closed	Open	Closed	125,000	9,250
Closed	Closed	Closed	Open	62,500	15,000

Table 38-2 DIP Switch S3

### DIP Switches S4 and S5

DIP switches S4 and S5 will allow you to select the mode of operation, baud rate, self test, and network size for COM ports 1 and 0, respectively. The following description covers both DIP switches.

Switch position one selects whether broadcast messages on the network should be received by the COM port.

<u>Switch Position 1</u>	<u>Function</u>
Open	Disable receive broadcast
Closed	Enable receive broadcast

Table 38-3 DIP Switches S4 and S5

**Note** The function of this switch changes depending on the mode selected (described later). The function given above for this switch position is for the SY/MAX mode of operation. When using a SY/MAX family CRT in the peripheral mode, this switch should be closed.

Switch positions two and three select the mode of operation. The PanelMate unit supports the SY/MAX mode only. Therefore, both of these switch positions should be in the closed state. The following table shows the possible mode selections.

<u>Switch Position</u>		<u>Mode</u>
<u>2</u>	<u>3</u>	
<b>Closed</b>	<b>Closed</b>	<b>SY/MAX</b>
Open	Closed	Net to Net
Closed	Open	8881
Open	Open	Peripheral

**Table 38-4 DIP Switches S4 and S5**

Switch positions four, five, and six select the COM port baud rate. The following table shows the possible baud rates.

<u>Switch Position</u>			<u>Baud Rate</u>
<u>4</u>	<u>5</u>	<u>6</u>	
Closed	Closed	Closed	19,200
Open	Closed	Closed	9,600
Open	Closed	Open	2,400
Open	Open	Closed	1,200
Open	Open	Open	300

**Table 38-5 DIP Switches S4 and S5**

Switch position seven on DIP switch S4 selects either normal operation or self test. The self test mode is used only for testing ports, RAM, and ROM on the NIM. The following table shows the possible switch selections.

<u>Switch Position 7</u>	<u>Function</u>
Open	Normal operation
Closed	Self test

**Table 38-6 DIP Switch S4**

The procedure for running the self test is described in the Square D Instruction Bulletin for your NIM.

Switch position seven on DIP switch S5 sets the network size. The following table shows the possible network size selections.

<u>Switch Position 7</u>	<u>Function</u>
Open	Network size = 100 (00-99)
Closed	Network size = 31 (00-30)

Table 38-7 DIP Switch S5

**Note** Reducing the network size to 31 modules will improve network access by a factor of three. Also, all modules on a network should have the same setting for this switch position. If this switch position on any of the modules is set to the closed state, the entire network size will be set to a maximum of 31.

## Square D Word and Bit References

---

The following section describes the use of Square D word and bit references in your configuration. The general word referencing method is:

[plcname,word#format]

The "plcname" is the name of the designated PLC as listed in the PLC Name and Port Table. The "word" is the reference number (address) of the word or register to be read or written. The "#format" is a code which specifies the format of the data being read or written. The "plcname" and "#format" are optional.

The general bit referencing method is:

[plcname,bit]

The "plcname" is the designated PLC as listed in the PLC Name and Port Table. The "bit" is the reference number (address) of the bit, coil, or input to be written or read.

See chapter 10 for a more detailed explanation of word and bit references, including format descriptions.

The Square D Sy/Max protocol is supported on the PanelMate unit for models 100, 300, 400, 500, 600, and 700. These models use decimal register addresses and bit offsets. Addresses and offsets all range from 1 to 16 (not from 0 to 15). The PanelMate unit format default is S16.

Note that this consists of a one-character prefix which identifies the type of variable being referenced followed by the specific number of the variable. The following list contains the memory types supported by the Square D driver.

- S - storage register
- R - internal relay logic
- N - external I/O
- O - external output
- I - external input

The prefixes are used to identify the usage of the variable to Square D. Each variable is uniquely identified by its number. Therefore, the prefix may be omitted from the reference (e.g., [11] may be used instead of [S11]).

The following is the format of a register reference.

[rr]  
rr                    PLC reference number of the register.

The following is the format of a register bit reference.

[rr-bb]  
rr                    PLC reference number of the register.  
bb                    PLC reference number of the bit position. The bit positions are numbered from 1 to 16, least significant to most significant, respectively.

The PanelMate unit does not support writing to protected registers. If a template attempts to modify the contents of a protected register, a communications error will result. Therefore, if an unexplainable communications error occurs, the user is suggested to check the BEGIN FENCED REGISTERS and END FENCED REGISTERS parameters with a Square D Programmer. All data referenced by the PanelMate unit must lie between these parameters.

The supported Square D PLC models will allow a maximum of 60 contiguous words per read. The maximum number of unused words before another read is generated is 15.

## Examples

The following are examples of valid PLC references which may be assigned in the PanelMate expression fields.

### Word References

<u>Reference</u>	<u>Description</u>
[S13]	Word 13 is placed in a storage register
[R12]	Word 12 is internal relay logic
[N3]	Word 3 is external I/O
[O5]	Word 5 is external output
[I9]	Word 9 is external input

### Bit References

<u>Reference</u>	<u>Description</u>
[S32-14]	Word 32 bit 14 is placed in a storage register
[R96-3]	Word 96 bit 3 is internal relay logic
[N54-15]	Word 54 bit 15 is external I/O
[O23-2]	Word 23 bit 2 is external output
[I16-4]	Word 16 bit 4 is external input

## Access Permitted by Maintenance Template

The Maintenance Template will access all memory locations supported by the PLC driver as defined in this chapter. When running online, you may change the PLC reference. The Maintenance Template is designed to assist you in specifying the PLC reference by scrolling through a list of mnemonics which are used to enter the PLC word reference. When online in the PLC reference change mode, the following list is available.

"S", "R", "N", "O", and "I"

You must enter the correct mnemonics and numeric values and create a legal reference to change a PLC reference. Once a new reference is entered, the Maintenance Template will remain in a paused state until the control button labeled "Start Monitor" is depressed. The PanelMate Series 1000 will then parse the reference. (Parsing means checking the syntax and range of the reference to ensure that it is supported by the driver.) If correct, the template begins updating.





# Chapter 39

## Texas Instruments PLCs

---

The PanelMate Series 1000 can be used with the programmable controllers in the Texas Instruments (TI) 500 Series (520, 530, 560, and 565), 405 Series (425, 430, and 435), and 305 Series (315, 325, and 330) using the TI driver or the TIHL (Host Link) driver. The driver takes responsibility for communications to the programmable controller, generating the protocol necessary to request information from, and send information to, the PLC. The PLC simply responds to these requests and commands. Ladder logic is required in the PLC to support bit writes to the TI 405 and TI 305 PLCs.

Connection to PLCs using the PanelMate TI or TIHL driver can be accomplished by a direct connection to the RS232 port, the Data Communication Module (DCM), or the Data Communications Unit (DCU). The RS232 connection can only be used Point-to-Point. RS422 has multi-drop capabilities.

# Memory

---

The following memory types are supported by the 500 Series driver:

<u>Memory Type</u>	<u>Memory Address</u>
<b>16-Bit Word</b>	
WX	WX Word Image Register
WY	WY Word Image Register
V	V Word Memory
DSP	Drum Step Preset
DSC	Drum Step Current Memory
DCP	Drum Count Preset Memory
DCC	Drum Count Current Memory (Read Only)
TCP	Timer/Counter Preset Memory
TCC	Timer/Counter Current Memory
LPV	Loop Process Variable
LMN	Output
LSP	Setpoint
LMX	Bias
<b>Bit</b>	
X	X Discrete Image Register
Y	Y Discrete Image Register
C	C Discrete Image Register

The following memory types are supported by the 405 Series driver:

<u>Memory Type</u>	<u>Memory Address</u>
<b>16-Bit Word</b>	
TMR	Timer
CNT	Counter
V	User Data
V	System Parameter
<b>Byte or Bit</b>	
GX	Remote I/O
X	Input
Y	Output
C	Control Relays
S	Stages
T	Timer Relays (Read Only)
CT	Counter Relays (Read Only)
SP	Special Relays (Read Only)

The following memory types are supported for the 305 Series driver:

<u>Memory Type</u>	<u>Memory Areas</u>
<b>16-Bit Word</b>	
AC	Timer/Counter Accumulator (Read Only - Model 315)
R	Data Registers (Not Supported - Model 315)
<b>Byte</b>	
R	Data Registers (Not Supported - Model 315) (Read Only - Models 325 and 330)
<b>Bit</b>	
IO	Input/Output, Internal Relay, Shift Register (IO373-IO377 is Read Only - Model 315) (IO374-IO377 is Read Only - Models 325 and 330)
T	Timer Element (Read Only - all models)
C	Counter Element (Read Only - all models)
TC	Timer/Counter Element (Read Only - all models)
SG	Stage Element

Memory addresses are in octal.

The following table shows the memory types and ranges supported by the 500 Series driver.

Memory Type	PLC Type			
	520	530	560	565
<b>16-Bit Word</b>				
WX	1-1023	1-1023	1-8192	1-8192
WY	1-1023	1-1023	1-8192	1-8192
V	1-1024	1-5120	1-228352	1-228352
DSP	1-30	1-30	1-1152	1-1152
DSC	1-30	1-30	1-1152	1-1152
DCC	1-30	1-30	1-1152	1-1152
TCP	1-128	1-400	1-10240	1-10240
TCC	1-128	1-400	1-10240	1-10240
DCP	1-30	1-30	1-1152	1-1152
LPV	-	-	-	1-64
LMN	-	-	-	1-64
LSP	-	-	-	1-64
LMX	-	-	-	1-64
<b>Bit</b>				
X	1-1023	1-1023	1-8192	1-8192
Y	1-1023	1-1023	1-8192	1-8192
C	1-511	1-1023	1-8192	1-8192

**Table 39-1 Memory Ranges for 500 Series Driver**

**Note** For the Drum memory type (DSP, DSC, DCP and DCC), the range represents the drum number. For DCP memory, the range of step values is 1-16. DCP values are entered using the format [DCPxx yy] where xx = drum number, yy = the step value.

The following table shows the memory types and ranges supported by the 405 Series driver.

Memory Type	Memory Address	V Memory Addresses
<b>16-Bit Word</b>		
Timer	TMR0-TMR177	V00000-V00177
Counter	CNT0-CNT177	V01000-V01177
User Data	V01400-V07377	V01400-V07377
System Param	V07400-V07777	V07400-V07777
<b>Byte or Bit</b>		
Remote I/O	GX0-GX777	V40000-V40037
Inputs	X0-X477	V40400-V40423
Outputs	Y0-Y477	V40500-V40523
Control Relays	C0-C737	V40600-V40635
Stages	S0-S577	V41000-V41027
Timer Relays	T0-T177 (Read Only)	V41100-V41107 (Read Only)
Counter Relays	CT0-CT177 (Read Only)	V41140-V41147 (Read Only)
Special Relays	SP0-SP137 (Read Only)	V41200-V41205 (Read Only)
Special Relays	SP0-SP137 (Read Only)	V41200-V41205 (Read Only)

**Table 39-2 Memory Ranges for 405 Series Driver**

The following table shows the memory types and ranges supported by the 305 Series driver.

Memory Type	PLC Type		
	315	325	330
<b>16-Bit Word</b>			
Timer/Counter Acc	AC600-AC624 (Read Only)	AC600-AC677	AC600-AC677
Data Registers	Not Supported	R400-R577	R400-R577
<b>Byte or Bit</b>			
Timer (Read Only)	T600-T624 (Not Available)	T600-T677	T600-T677
Timer/Counter (Read Only)	TC600-TC624 (Not Available)	TC600-TC677	TC600-TC677
Counter (Read Only)	C600-C624 (Not Available)	C600-C677	C600-C677
Input/Output	IO000-IO017 (Read Only)	IO000-IO373	IO000-IO373
	IO20-IO357	IO374-IO377 (Read Only)	IO374-IO377 (Read Only)
	IO360-IO377 (Not Available)	IO400-IO577	IO400-IO577
		IO700-IO777	IO700-IO777
Stage	SG000-SG137	SG000-SG173	SG000-SG173
		SG174-SG177 (Read Only)	SG174-SG177 (Read Only)
		R400-R577	R400-R577

**Table 39-3 Memory Ranges for 305 Series Driver**

**Note** When using the 315 model, updates may take up to two minutes. The slow update times are due to limitations within the 315 model not the PanelMate unit.

**Note** For models 325 and 330, byte IO370 and SG170 are read only.

# Possible Configurations

---

Examples of possible configurations are described and shown in the following figures.

## Direct

---

See the TI manual for your PLC to set the baud rate for the port on the CPU.

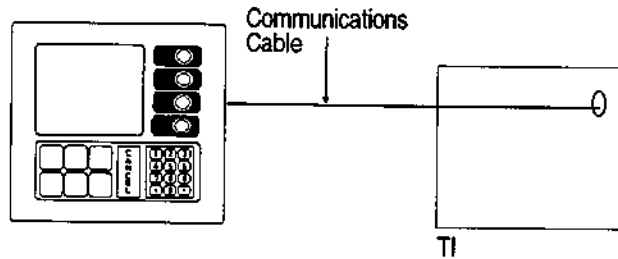


Figure 39-1 Direct Connection

## Direct with DCPM

---

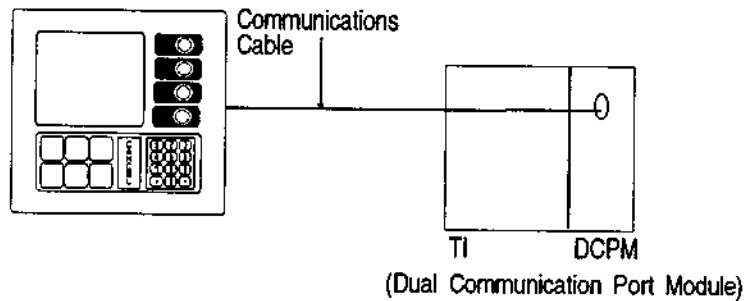


Figure 39-2 Connection to a DCPM

## Direct with DCU

---

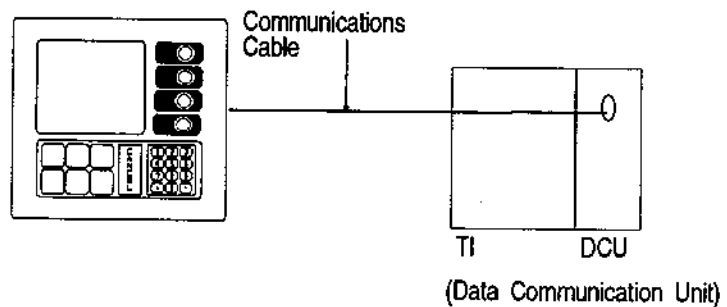


Figure 39-3 Connection to a DCU

# Cabling

Communications between the PanelMate unit and TI 500 PLCs is RS232. Communications between 405 and 305 PLCs can be RS232 or RS422. The maximum cable length when using RS232 is 50 feet, while the maximum cable length for RS422 is 4000 feet. RS422 cable must be a twisted double-wire shielded cable. All PanelMate unit ports are female 9-pin (DB-9S), so the connectors on the cables must be male 9-pin (DB-9P).

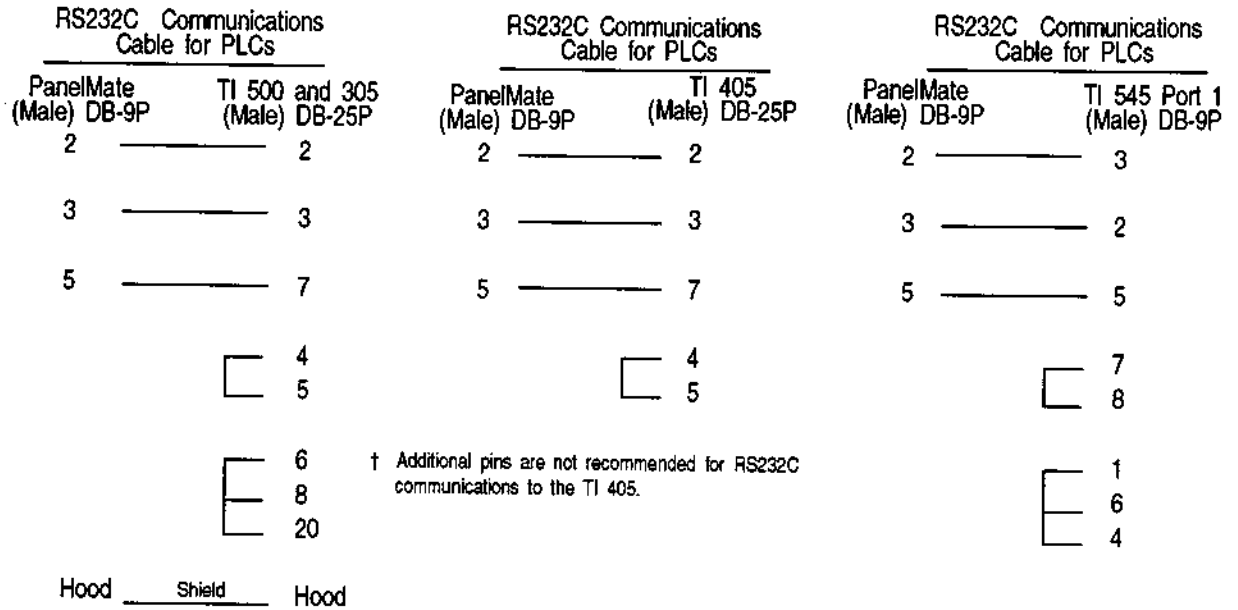


Figure 37-4 RS232C Cabling for TI PLCs

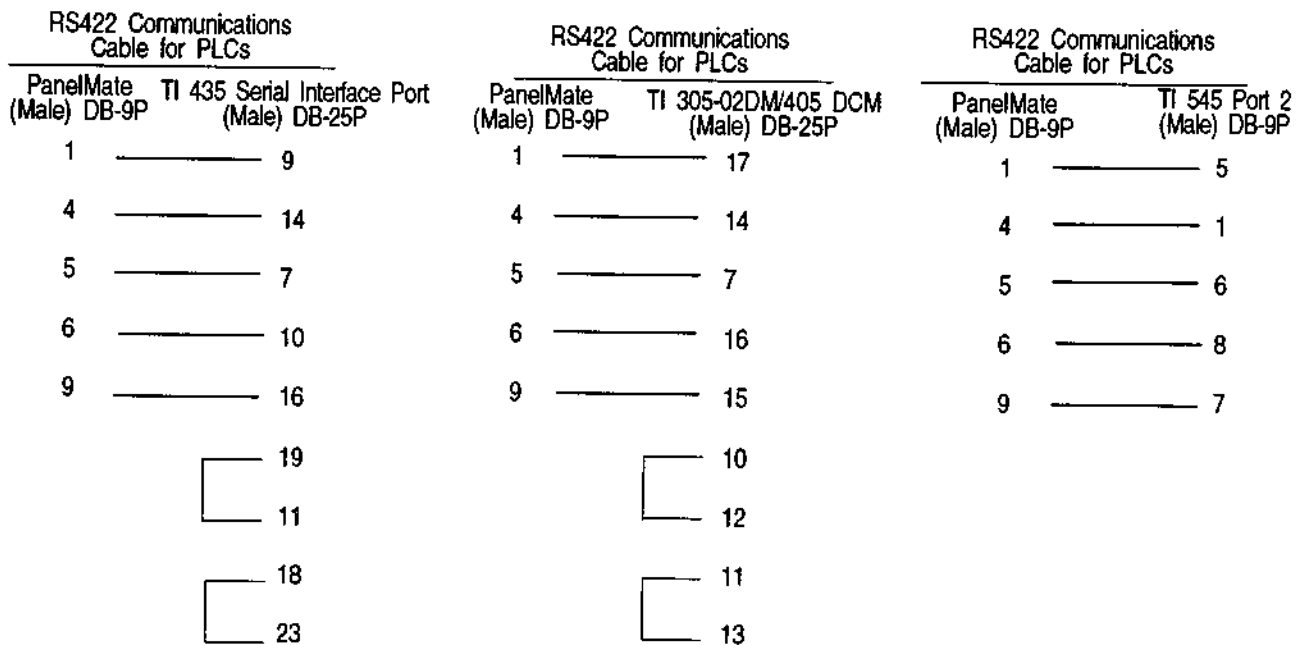


Figure 39-5 RS422 Cabling for TI 405, 305, and 545 PLCs

# Communications Parameters

## Dual Communication Port Module TI 500 Series

The Dual Communication Port Module (DCPM) has two RS232/423 ports which work independently and permit simultaneous communication. The PanelMate unit does not support RS423. RS232 must be used for communications. The two ports are identical to the programming port on the PLC. All communication is serial with one stop bit at all baud rates, except at 110 baud, which has two stop bits. The ports may be configured for a baud rate ranging from 110 to 19.2K, and also for DTE or DCE mode. Standard communication parameters for communicating with TI PLCs are shown below. These parameters are given only as a starting point and may be changed to meet the demands of your application.

- 7 Data Bits
- 1 Stop Bit
- Odd Parity
- 9600 Baud

Under the front access cover are two dipswitch banks. The upper dipswitch bank is for configuring port 1, while the lower dipswitch bank is for configuring port 2. The configuration switches are shown in the following figure.

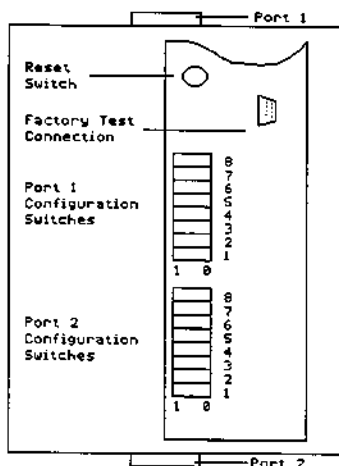


Figure 39-6 Dipswitch Bank Locations

Set switch 4 to the 1 position to select DTE mode or into the 0 position to select DCE mode. Switches 5 through 8 are not used.

Baud Rate	110	300	600	1200	2400	4800	9600	19.2K
Switch 1	0	1	0	1	0	1	0	1
Switch 2	0	0	1	1	0	0	1	1
Switch 3	0	0	0	0	1	1	1	1

Table 39-4 Baud Rate Selection

## Serial Interface Port TI 435 PLC

The Serial Interface Port enables the TI 435 PLC to interface directly to the PanelMate unit.

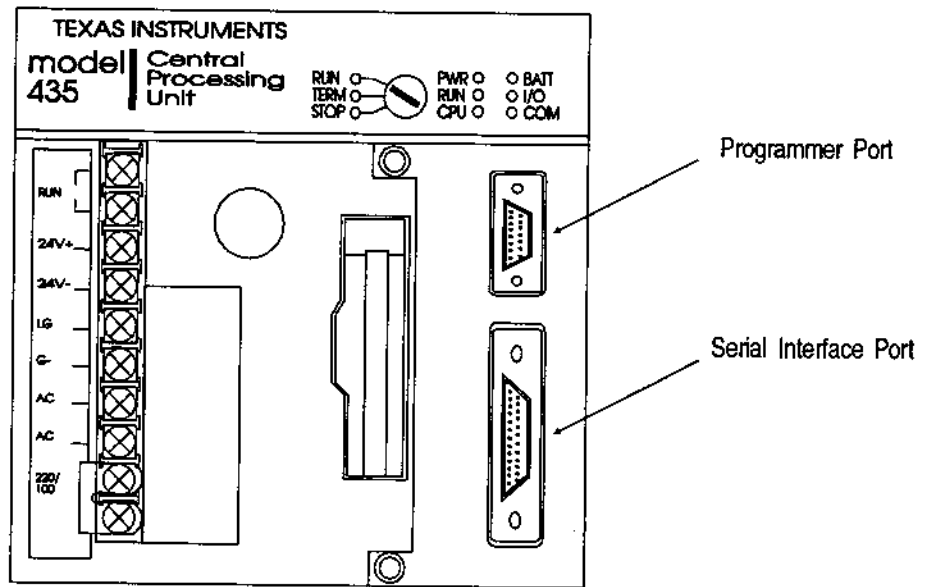
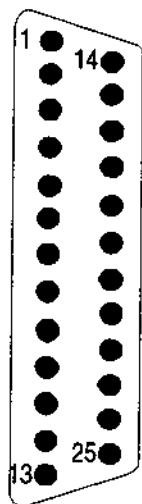


Figure 39-7 Texas Instruments 435 Serial Interface Port

Figure 39-8 shows the pinouts for the Serial Interface Port.



Pin	Name	Pin	Name
1	Not Used	14	TXD+
2	TXD	15	Not Used
3	RXD	16	TXD-
4	RTS	17	Not Used
5	CTS	18	RTS-
6	Not Used	19	RTS+
7	SG	20	Not Used
8	Not Used	21	Not Used
9	RXD+	22	Not Used
10	RXD-	23	CTS-
11	CTS+	24	Not Used
12	Not Used	25	Not Used
13	Not Used		

Table 39-8 Serial Interface Port

Communication to the TI 435 is through the Host Link Protocol in Master/Slave mode. The PanelMate unit uses hexadecimal data protocol, not ASCII. Note that the data protocol and parity are set with the TI programming software in the Auxiliary Function 26, Set Secondary Address. Standard communication parameters for communicating directly with the TI 435 Serial Interface Port are shown below.

- 8 Data Bits
- 1 Stop Bit
- Odd Parity
- 300 to 19200 Baud Rate\*

\* The baud rate is dipswitch selectable.

<u>Switch</u>	<u>ON</u>	<u>OFF</u>
SW1	CPU battery disabled	CPU battery enabled
SW2	Station address is 1	Station address is set via MIU (Machine Interface Unit) or programming software
SW3	Baud rate selection for Serial Interface Port	
SW4	Baud rate selection for Serial Interface Port	

**Table 39-5 Dipswitch Settings**

The dipswitch block is located at the rear of the CPU. Table 37-5 summarizes the dipswitch settings for the CPU dipswitch.

<u>Baud</u>	<u>SW3</u>	<u>SW4</u>
300	Off	Off
1200	Off	On
9600	On	Off
19200	On	On

**Table 39-6 Dipswitch Settings for Baud Rate**

SW3 and SW4 on the dipswitch control the baud rate at which the Serial Interface Port will operate. Refer to table 37-6 for the baud rates corresponding to the settings of SW3 and SW4.

## Data Communication Module TI 405 Series

The Data Communication Module (DCM) enables the TI Series 405 PLCs to interface with the PanelMate unit. The DCM supports the Hostlink protocol either Master/Slave or Peer-to-Peer. In the Master/Slave configuration PanelMate unit will be the Master device and the DCM will be the slave device in both the Point-to-Point and the Multidrop configurations. The DCM has a serial connection which will connect to the multi-drop network or directly point-to-point to the PanelMate unit.

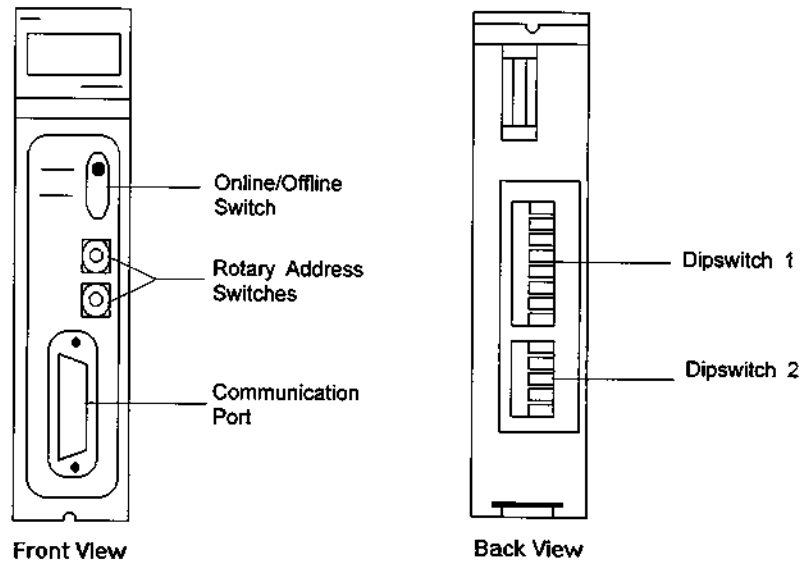


Figure 39-10 Switch Locations

There are two rotary switches on the DCM which select the network address of the PLC. This address must match the assigned PLC ID in the PLC Name and Port Table. There are two dipswitches located on the DCM. Dipswitch 1 sets the communication parameters. Switches 1, 2, and 3 of dipswitch 1 select the baud rate. Switch 4 sets the parity. Switch 5 must be set to Off. Switches 6 through 8 set the Response Time Delay. This should be set to 0ms.

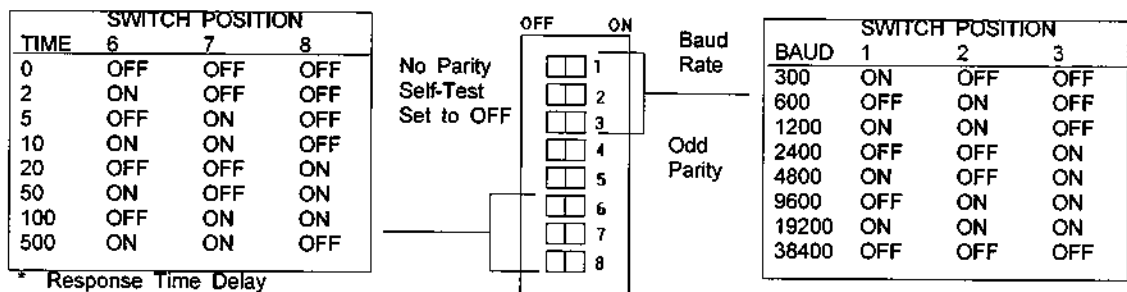
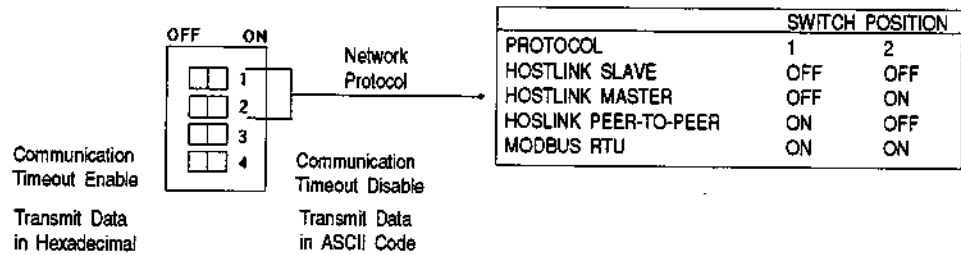


Figure 39-9 Dipswitch 1

Dipswitch 2 sets the communication protocol and communication functions. Switch 1 and 2 select the protocol to be used. The following table shows the valid switch settings for the PanelMate unit Interface.

<u>PanelMate unit Port</u>	<u>Protocol</u>	<u>Switch 1</u>	<u>Switch 2</u>
TI-HL/M	Hostlink Slave	OFF	OFF
TI-HL/P	Hostlink P/P	ON	OFF

Switch 3 and 4 of dipswitch 2 should be set to OFF to enable communication timeout and to allow data to be transmitted in hexadecimal.



**Figure 39-11 Dipswitch 2**

The following parameters are the default port characteristics of the DCM.

- RS422
- 8 Data Bits
- 1 Stop Bit
- Odd Parity
- Baud Rate 9600
- Master-Slave

## Data Communication Unit (DCU) TI 305 Series

The Data Communication Unit (DCU) enables the TI Series 305 PLCs to interface with external devices. The DCU only supports the master/slave protocol. The PanelMate unit will be the master device and the DCU will be the slave. When selecting a port use in the PLC Name and Port Parameters Table, use TI-HL/M (Texas Instruments Hostlink master/slave). The two DCU models are 305-02DM and 305-03DM. The 305-02DM has one RS422 port and can be multi-dropped from a network with up to 90 (405 or 305) controllers. This model also supports a point-to-point connection. The 305-03DM has one RS-232 port and must use a point-to-point connection.

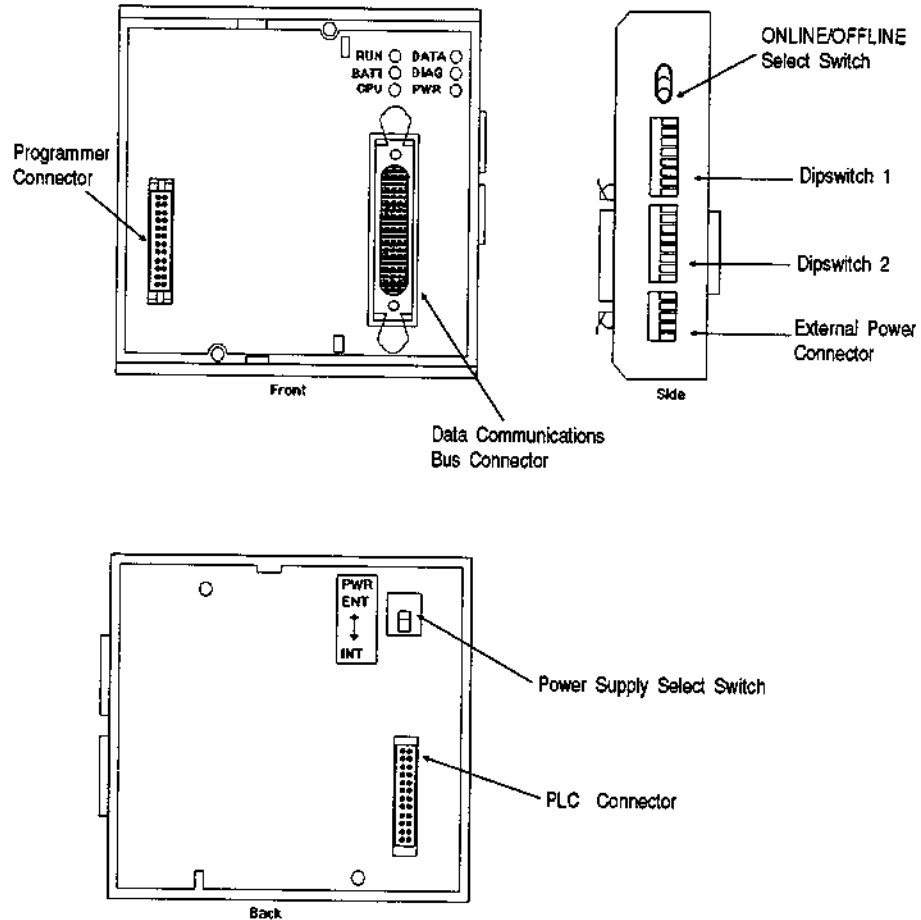


Figure 39-12 Data Communications Unit

There are two dipswitches located on the DCU. Dipswitch 1 selects the baud rate and internal functions. Switches 1 and 2 of dipswitch 1 select the baud rate. Switches 3 through 8 select the internal functions of dipswitch 1. See the following tables for the recommended settings.

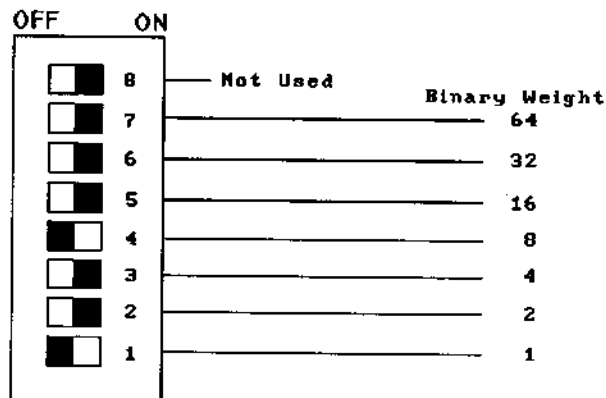
<u>Baud Rate</u>	<u>Switch 1</u>	<u>Switch 2</u>
300	Off	Off
1200	On	Off
9600	Off	On
19200	On	On

**Table 37-7 Baud Rate Settings for Dipswitch 1**

<u>Switch</u>	<u>Function</u>	<u>Setting</u>
3	Parity	Odd or None
4	Self-Diagnostic	Operate
5	Turn-Around Delay	No Delay
6	Mode at Power Up	PGM or Run
7	Not Used	
8	Transmission Mode	HEX

**Table 39-8 Internal Functions Settings for Dipswitch 1**

Dipswitch 2 sets the slave address of the PLC. This must match the PLC ID in the PLC Name and Port Parameters Table. The station number can be any number from 1 to 90. The switches are set in binary with switch 1 representing the least significant bit. See the following figure for an example of dipswitch 2 with the station number set to 9.



**Figure 39-13 Dipswitch 2**

## Bit Writes With Ladder Logic - 405 Series

The Texas Instruments Hostlink Protocol does not permit an external intelligent device to directly alter the state of a single bit without overwriting the entire byte in which that bit exists. As a result, the PanelMate unit will write values to designated registers in the PLC, specifying which bit should be set or cleared. It is necessary to write a section of Ladder Logic/Stage Programming to interpret this value in order to change the appropriate bit. The PanelMate unit will write to four V memory registers to set or reset a bit. The four registers will be consecutive starting with the Bit Write register entered in the PLC ID field. If a Bit Write register is not entered, the register will default to V7374. When the default register is used, V7374, V7375, V7376 and V7377 will be used to accomplish the Bit Writes.

Register 1	This register contains a 16-bit mask in which the bit position to be set will be set to 1 and all other bits will be set to 0.
Register 2	Each memory type has a corresponding V memory address. Register 2 contains the V Memory address in which the bit to be set is located.
Register 3	This register contains a 16-bit mask in which the bit position to be reset will be set to 0 and all other bits will be set to 1.
Register 4	This register contains the V memory address in which the bit to be reset is located.

### PLC ID Field

The format for the PLC ID for the TI 405 will include both the PLC ID and a memory register used for the four Bit Write Registers. The format will be the PLC ID followed by the memory address.

XX-VYYYYY or XX-YYYYY or XX

Where

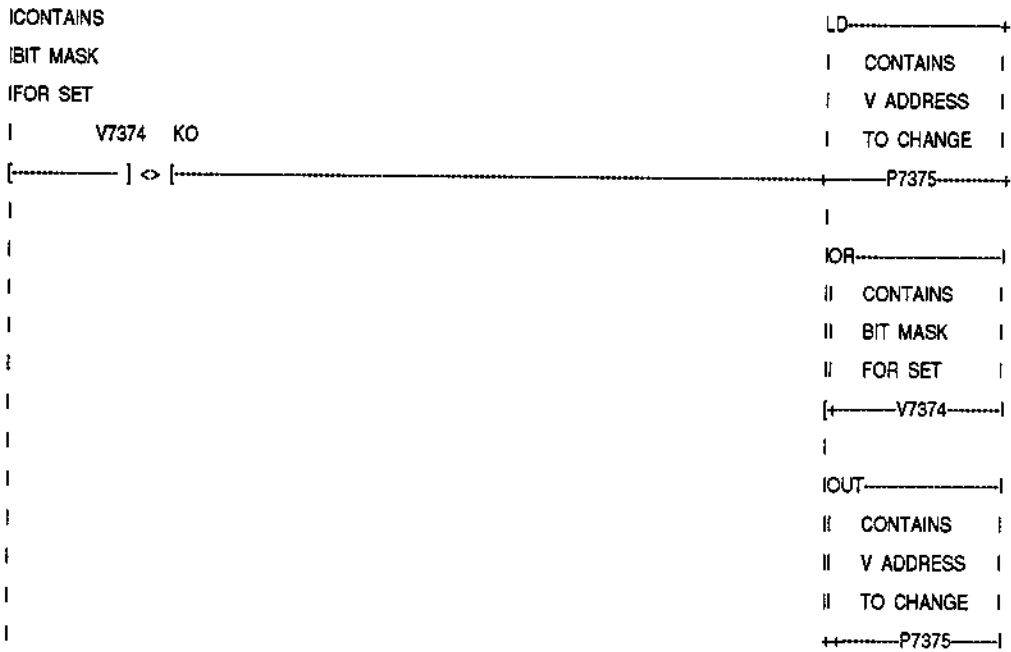
XX	PLC ID in range 1 - 90
-	PLC ID/memory address separator
V	Optional memory type specifier
YYYYY	Optional starting V memory address in range 1400 - 7374

If a memory address is not entered, the Bit Write register will default to V7374. The following ladder logic rungs may be added to a TI 405 program for the purpose of setting and clearing individual bits.

```

|           IF SET MASK IS PRESENT, LOAD ACCUMULATOR WITH TARGET WORD
|           VALUE, PERFORM LOGICAL OR WITH MASK IN V7374 AND RETURN
|           TARGET WORD VALUE.
|

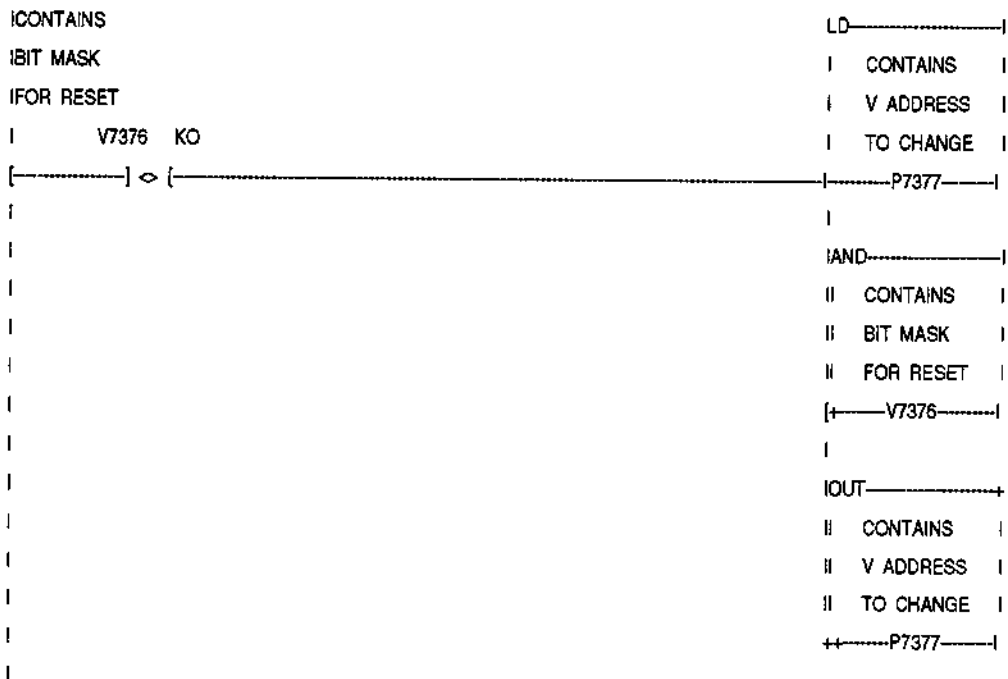
```



```

|           IF RESET MASK IS PRESENT, LOAD ACCUMULATOR WITH TARGET WORD
|           VALUE, PERFORM LOGICAL AND WITH VALUE IN V7376 AND RETURN
|           TARGET WORD VALUE.
|

```





## Bit Writes with Ladder Logic - Model 315

The Texas Instruments Hostlink Protocol does not permit an external intelligent device to directly alter the state of a single bit without overwriting the entire byte in which that bit exists. As a result, the PanelMate unit will write values to designated registers in the PLC, specifying which bit should be set or cleared. A section of Ladder Logic/Stage Programming is necessary to interpret this value in order to change the appropriate bit. The PanelMate unit will write to two consecutive bit/byte memory registers to set or reset a bit. The starting register that PanelMate unit will write to is determined by the register entered in the PLC ID field. If a Bit Write register is not entered, the register will default to IO340. When the default register is used, bytes IO340 and IO350 will be used to accomplish bit writes.

The following describes the values that will be written to the memory addresses:

Byte 1	This byte will be used to set bits 0-177. To set a particular bit, the actual bit number (octal) will be sent to this byte value. To reset the same bit, the bit number (octal) plus 200 (octal) will be sent to this byte value.
Byte 2	This byte will be used to set bits 200-373. To set a particular bit, the actual bit number (octal) minus 200 (octal) will be sent to this byte value. To reset the same bit, the bit number will be sent to this byte value.

Two rungs of ladder logic will be required for each bit write. Each rung will test the individual bits within the specified byte memory location for the bit pattern expected from the PanelMate unit. If the rung is true, the logic will set or reset a particular bit as required.

## PLC ID

The format for the PLC ID for the model 315 will include both the PLC ID and a memory register used for the two Bit Write registers. The format will be the PLC ID followed by the memory address.

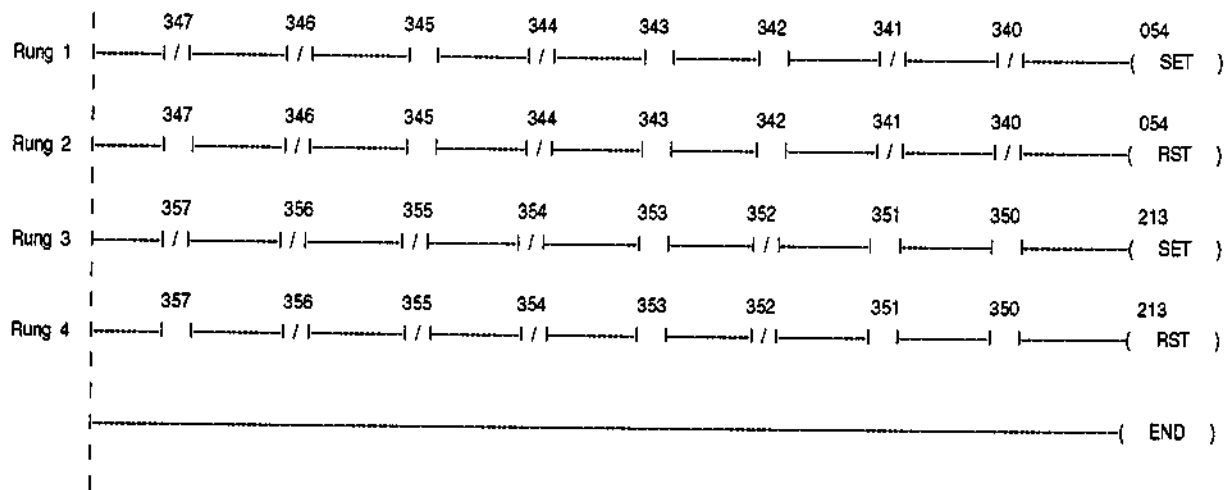
XX-IOYYY or XX-YYY or XX

Where

XX	PLC ID in range 1-90
-	PLC ID/memory address separator
IO	Optional memory type
YYY	Optional starting IO byte memory address in range 0-340.

**Note** In the PLC ID field, IO will default to a byte address.

The memory address must be on an 8-bit boundary. If an IO memory address is not entered, the Bit Write register will default to IO340. The following ladder logic rungs are an example of setting and clearing bits that may be added to a model 315 program for the purpose of setting and clearing individual bits.



**Example 1:**

With a bit write to IO054, the PanelMate unit will write 54 octal (44 decimal). Rung 1 tests for bit pattern 0010 1100 in byte IO340 and sets IO054.

The PanelMate unit will also write 254 octal (172 decimal) to byte IO340. Rung 2 tests for bit pattern 1010 1100 in byte IO340 and resets IO054.

**Example 2:**

With a bit write to IO213, the PanelMate unit will write 13 octal (11 decimal). Rung 3 tests for bit pattern 0000 1011 in byte IO350 and sets IO213.

The PanelMate unit will also write 213 octal (139 decimal) to byte IO350. Rung 4 tests for bit pattern 1000 1011 in byte IO350 and resets IO213.

**Bit Writes with Ladder Logic - Models 325 and 330**

The Texas Instruments Hostlink Protocol does not permit an external intelligent device to directly alter the state of a single bit without overwriting the entire byte in which that bit exists. As a result, the PanelMate unit will write to a designated register in the PLC, specifying which bit should be set or cleared. A section of Ladder Logic Programming is necessary to be written to interpret this value in order to change the appropriate bit. The starting register that PanelMate unit will write to is determined by the register entered in the PLC ID field. If a Bit Write register is not entered, the register will default to AC677.

To set a bit, the bit number will be sent to the Bit Write Register. To reset a bit, the bit number (decimal) + 1000 (decimal) will be sent to the bit write register.

Two rungs of ladder logic will be required for each bit write. Each rung will test the specified register for the expected value from the PanelMate unit. If the rung is true, the logic will set or reset a particular bit as required.

## PLC ID

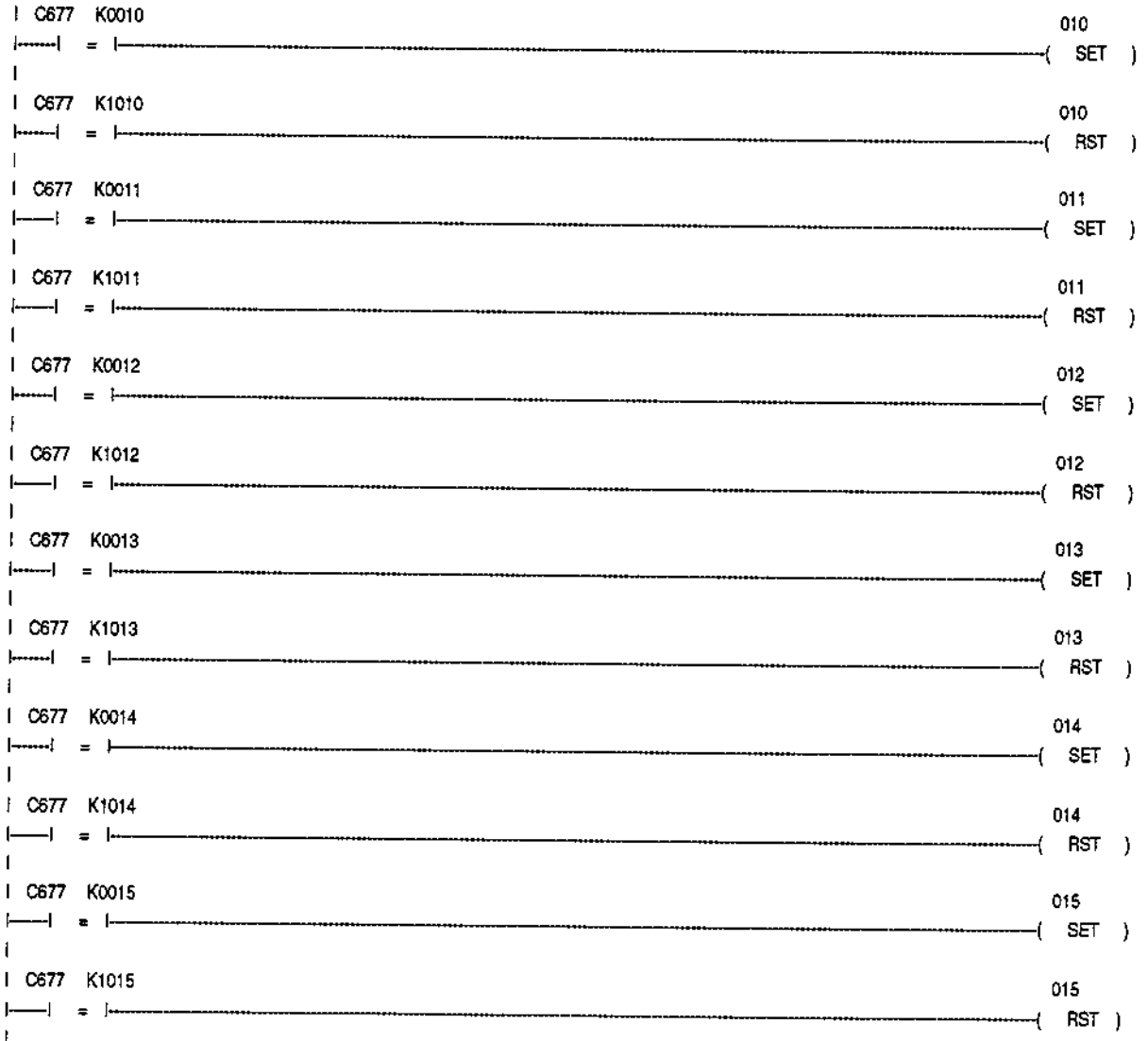
The format for the PLC ID for models 325 and 330 will include both the PLC ID and a memory register used for the Bit Write register. The format will be the PLC ID followed by the memory address.

XX-ACYYY or XX-YYY or XX

Where

XX      PLC ID in range 1-90  
-      PLC ID/memory specifier  
AC      Optional memory type  
YYY     Optional starting AC memory address in range 600-677

If an AC memory address is not entered, the Bit Write register will default to AC677. The following ladder logic rungs are an example of setting or clearing bits that may be added to models 325 and 330 program for the purpose of setting and clearing individual bits.



```

| C677 K0016                                     016
|-----| = |-----( SET )
|
| C677 K1016                                     016
|-----| = |-----( RST )
|
| C677 K0017                                     017
|-----| = |-----( SET )
|
| C677 K1017                                     017
|-----| = |-----( RST )
|
|----- ( END )

```

## Texas Instruments Word and Bit References

The following section describes the use of Texas Instruments word and bit references in your configuration. The general word referencing method is:

[plcname,word#format]

The "plcnam" is the name of the designated PLC as listed in the PLC Name and Port Table. The "word" is the reference number (address) of the word or register to be read or written. The "#format" is a code which specifies the format of the data being read or written. The "plcname" and "#format" are optional.

The general bit referencing method is:

[plcname,bit]

The "plcname" is the designated PLC as listed in the PLC Name and Port Table. The "bit" is the reference number (address) of the bit, coil, or input to be written or read.

See chapter 10 for a more detailed explanation of word and bit references, including format descriptions.

### 500 Series Word and Bit References

Texas Instruments 520, 530, 560 and 565 PLCs use decimal word addresses. The PanelMate unit format default is U16.

The following is the format for an output reference.

[YY]

YY

PLC reference number of the output.

## 405 Series Word, Byte, and Bit References

Texas Instruments 405 PLCs use octal word addresses. The PanelMate unit format default is U16. The following is the format for a register reference.

[XY]	
X	Memory type (TMR, CNT, and V)
Y	Word address (leading zeroes not required)

To reference a byte value, the memory address must be on an 8-bit boundary. The following is the format for an 8-bit (byte) reference.

[B:XY]	
B	Designating byte reference
:	Byte designator/byte address separator
X	Memory type (GX, X, Y, C, S, T, CT, and SP)
Y	Byte address

The following is the format for a bit referenced within a word.

[XY/B]	
X	Memory type (TMR, CNT, and V)
Y	Word address (leading zeroes not required)
B	Bit number in the range (0 - 17 in octal) (read only)

The following is the format for a single bit reference (device).

[XY]	
X	Memory type (GX, X, Y, C, S, T, CT, and SP)
Y	Bit address (leading zeroes not required)

### 305 Series Word and Bit References

Texas Instruments 305 PLCs use octal word addresses. The PanelMate unit format default is U16. The following is the format for a register reference.

[XY]	
X	Memory type (AC and R - for 325 and 330 models)
Y	Word address (leading zeroes not required)

**Note** The Data Register (R) is 8-bits with this format.

The following is the format for a 16-bit data register reference.

[W:RY]	
W	Designating 16-bit word reference
:	16-bit designator/address separator
R	Data register specifier
Y	Word address

To reference a byte value, the memory address must be on an 8-bit boundary. The following is the format for a 8-bit (byte) reference

[B:XY]	
B	Designating byte reference
:	Byte designator/byte address separator
X	Memory type (IO,T, TC, C, and SG)
Y	Byte address

**Note** Write restrictions that apply to each bit memory type also apply to the byte references. Byte IO370 is read only.

The following is the format for a bit referenced within a word.

[XY/B]

X	Memory type (AC and R - for 325 and 330 models)
Y	Word address (leading zeroes not required)
/	Delimiter to separate bit number
B	Bit number in the range (0-17, 0-7 for Data Register)

or

[W:RY/B]

W	Designating word reference
:	Word designator/ address separator
R	Memory type (R - for 325 and 330 models)
Y	Word address
/	Delimiter to separate bit number
B	Bit number in the range (0-17)

The following is the format for a single bit reference (device).

[XY]

X	Memory type (IO, T, TC, C, and SG)
Y	Bit address (leading zeroes not required)

## Examples

The following are examples of valid PLC references which may be assigned in the PanelMate unit expression fields.

### 500 Series

#### Word References

<u>Reference</u>	<u>Description</u>
[WX12]	Word image register 12
[WY18]	Word image register 18
[V22]	V Word memory 22
[DSP12]	Drum step preset 12
[DSC15]	Word 15 of drum step current memory
[DCC9]	Word 9 of drum count current memory
[TCP4]	Word 4 of timer/counter preset memory
[TCC19]	Word 19 of timer/counter current memory
[LPV34]	Word 34 of loop process variable
[LMN43]	Output word 43
[LSP44]	Setpoint word 44
[LMX61]	Bias word 61

#### Bit References

<u>Reference</u>	<u>Description</u>
[X520]	Bit 520 of a discrete image register
[Y680]	Bit 680 of a discrete image register
[C7123]	Bit 7123 of a discrete image register
[DCP30 16]	Step 16 of drum 30 of drum count preset memory

## 405 Series

### Word References

[TMR11]	Timer register 11
[CNT30]	Counter register 30
[V24]	User Data register 24

### Byte References

[B:GX10]	Remote I/O register 10
[B:X20]	Input register 20
[B:Y100]	Output register 100
[B:C30]	Control relay register 30
[B:S40]	Stage register 40
[B:T50]	Timer relay register 50
[B:CT170]	Counter relay register 170
[B:SP0]	Special relay register 0

### Bit References

[GX12]	Bit 12 of remote I/O memory
[X315]	Bit 315 of input memory
[CNT.50/10]	Bit 10 of counter word 150

## 305 Series

### Word References

[AC614]	Timer/ Counter register 614
[W:R502]	Data register 502 (325 or 330 models only)

### Byte References

[R12]	Data register 12 (325 or 330 models only)
[B:T611]	Timer register 611
[B:SG20]	Stage register 20

### Bit References

[IO12]	Input/Output register 12
[T617]	Timer element 617
[C622]	Counter element 622
[TC600]	Timer/Counter element 600
[SG43]	Stage element 43
[W:R510/11]	Bit 11 of data register 510 (325 or 330 models only)
[AC613/17]	Bit 17 of timer accumulator word 613.

## Access Permitted by Maintenance Template

---

The Maintenance Template will access all memory locations supported by the PLC driver as defined in this chapter. When running online, you may change the PLC reference. The Maintenance Template is designed to assist you in specifying the PLC reference by scrolling through a list of mnemonics which are used to enter the PLC word reference. When online in the PLC reference change mode, the following list is available.

TI 305	"AC", "R", "IO", "T", "C", "TC", "SG", "W:", "B:", and "/",
TI 405	"TMR", "CNT", "V", "GX", "X", "Y", "C", "S", "T", "CT", "SP", "B:", and "/"
TI 500	"X", "Y", "WX", "WY", "C", "V", "DSP", "DSC", "DCP", "DCC", "TCP", "TCC", "LPV", "LMN", "LSP", and "LMX"

You must enter the correct mnemonics and numeric values and create a legal reference to change a PLC reference. Once a new reference is entered, the Maintenance Template will remain in a paused state until the control button labeled "Start Monitor" is depressed. The PanelMate Series 1000 will then parse the reference. (Parsing means checking the syntax and range of the reference to ensure that it is supported by the driver.) If correct, the template begins updating.





# Chapter 40

## Westinghouse Numa-Logic PLCs

---

The PanelMate Series 1000 may be used with any of the programmable controllers in the Westinghouse Numa-Logic family using the Westinghouse driver. The driver takes responsibility for communications to the controller, generating the protocol necessary to request information from, and send information to, the PLC. No ladder logic is required in the PLC to support the interface to the PanelMate unit.

# Memory

---

The following are the different prefixes which may be assigned to Westinghouse PLC references used in the PanelMate unit:

<u>Prefix</u>	<u>Type</u>	<u>Prefix</u>	<u>Type</u>
AD	Discrete Output	IM	Discrete Output
BD	Discrete Output	LS	Discrete Output
BF	Discrete Output	MB	Discrete Output
BO	Discrete Output	MR	Discrete Output
BC	Discrete Output	MV	Discrete Output
BS	Discrete Output	NL	Discrete Output
CD	Discrete Output	NR	Discrete Output
CR	Discrete Output	OG	Discrete Output
DB	Discrete Output	OR	Register Output
DC	Discrete Output	SB	Discrete Output
EQ	Discrete Output	SK	Discrete Output
GE	Discrete Output	TR	Discrete Output
HR	Holding Register	TS	Discrete Output
IG	Discrete Input	TT	Discrete Output
IR	Register Input	UC	Discrete Output
IN	Discrete Input	UI	Discrete Output

**Table 40-1 Memory Types**

Memory types IR, IG, OR, OG, and HR all support the BP (Bit Pick) prefix to specify individual bits within the word.

The following are the ranges for the different Westinghouse PLC models supported by the PanelMate unit:

<u>Memory Type</u>	PC-700		PC-900		PC-1100	
	<u>Min</u>	<u>Max</u>	<u>Min</u>	<u>Max</u>	<u>Min</u>	<u>Max</u>
Discrete Inputs	1	256	1	128	1	64
Discrete Outputs	1	512	1	255	1	256
Register Inputs	1	32	1	16	1	8
Register Outputs	1	32	1	16	1	8

**Table 40-2 Memory Ranges**

**Note** To determine the maximum range for IG and OG memory, divide the discrete input maximum amount by 16. The minimum is 0.

# Possible Configurations

## Direct

The PanelMate unit can communicate with a Westinghouse PLC through a direct connection using Numa-Logic 6-byte protocol. This protocol allows direct access to any part of the memory in the Westinghouse programmable controller. The station address, Network ID number, and PLC unit number are not used.

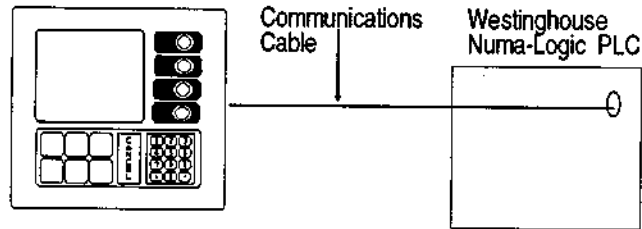


Figure 40-1 Direct Connection

## Cabling

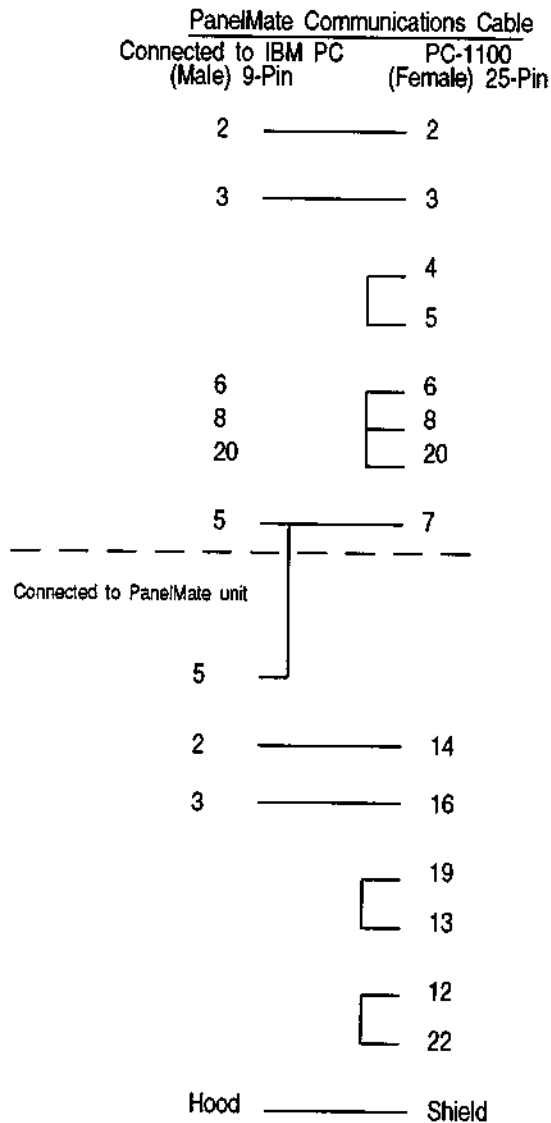
The communication between the PanelMate unit and the Westinghouse module is RS232C. The recommended maximum cable length is 50 cable feet. All PanelMate unit ports are female 9-pin (DB-9S), so the connectors on the cables must be male 9-pin (DB-9P).

RS232C Communications Cable  
for Westinghouse Numa-Logic

PanelMate (Male) DB-9P	Westinghouse Numa-Logic (Female) 25-Pin
2	2
3	3
	4
	5
	6
	8
	20
5	7
Hood	Shield

Figure 40-2 RS232C Cabling for Westinghouse PLCs

If you are using a PLC model which supports two communications channels through one 25-pin connector, a special variation of the previous cable can be made to allow access to both ports by different devices at the same time. In this manner, both the PanelMate unit and another device, such as an IBM PC used for PLC programming, could be connected to a PC-1100 simultaneously.



**Figure 40-3 Multiple Connections to PC-1100**

## Communications Parameters

In both the PC-700 and PC-900, the configuration of RS-232 ports is identical. The PC-700 exists in two versions, one having a single port, another having dual ports. The PC-900 and PC-1100 have a single port.

The standard communications parameters for communicating with Westinghouse PLCs are:

- 8 Data bits
- 1 Stop bit
- Odd Parity
- 9600 Baud

The supported Westinghouse PLCs do not have switches for changing the communications parameters. See the appropriate Westinghouse PLC manual for more information.

# Westinghouse Word and Bit References

---

The following section describes the use of Westinghouse word and bit references in your configuration. The general word referencing method is:

[plcname,word#format]

The "plcname" is the name of the designated PLC as listed in the PLC Name and Port Table. The "word" is the reference number (address) of the word or register to be read or written. The "#format" is a code which specifies the format of the data being read or written. The "plcname" and "#format" are optional.

The general bit referencing method is:

[plcname,bit]

The "plcname" is the designated PLC as listed in the PLC Name and Port Table. The "bit" is the reference number (address) of the bit, coil, or input to be written or read.

See chapter 10 for a more detailed explanation of word and bit references, including format descriptions.

The PanelMate unit restricts the access of variables to the maximum ranges of addresses allowed for the type of variable on the model of processor being used. If the address is outside this maximum range, an error is signaled to the user.

All five variable types occupy different locations in memory. It is, therefore, important that the correct prefix be used. The letters in the prefix may be any combination of capital and small letters.

There are a number of special functions supported in the PanelMate unit's Westinghouse driver. Each of these has a prefix associated with it which may be substituted for one of the prefixes above.

A specific bit may be referenced within any word. There are two formats available to do this. The first format is consistent with that generally used by the PanelMate unit with other brands of PLCs. It consists of the word reference, a space, and the bit offset. An example of this is [IG2 14]. The other format is based upon the Bit Pick function built into Westinghouse PLCs. The Bit Pick prefix (BP) is entered, followed immediately by the bit offset. Next, a slash is entered, followed by the word reference. The above example may be redone in this format as [BP14/IG2].

There are two types of discrete points: input and output. Examples of these are IN0002 and CR0042, respectively. Each of these accesses one point in an input group or an output group. Therefore, in addition to referencing discrete input/output points in the manner described in the previous paragraph, input points or output points may be referenced using INnnnn or CRnnnn. Example: [BP14/IG2] may also be expressed as [IN0030]. Refer to Westinghouse documentation for additional instructions and information concerning the two formats.

Also, Westinghouse provides a number of different type prefixes for the user. These prefixes do not change the type of variable being referenced but define its usage within the program. These prefixes may also be used on the PanelMate unit. Example: TS0004 references the same I/O point as CR0004, but defines the usage of the bit as Timer Seconds. The PanelMate unit supports all prefixes known to be used at this time. Consult your Westinghouse documentation for further information regarding the above.

Westinghouse Numa-Logic PLCs (PC-700, PC-900 and PC-1100) use decimal register addresses and bit offsets. Addresses and offsets all start from 1 (e.g., bit offsets range from 1 to 16, not from 0 to 15). The default data format is S16.

A typical Westinghouse holding register reference in a PanelMate unit expression may be [HR19]. Note that this consists of a two-character prefix which identifies the type of variable being referenced, followed by the specific number of the variable. There are several other types of word-length variables that are addressed in this manner. The prefix and a brief description of each data type are given below:

IR	Input Register
OR	Output Register
IG	Input Group
OG	Output Group
HR	Holding Register

The supported Westinghouse PLC models will allow a maximum of 60 contiguous words per read. The maximum number of unused words before another read is generated is 15.

## Examples

The following are examples of valid PLC references which may be assigned in the PanelMate expression fields.

### Word References

<u>Reference</u>	<u>Description</u>
[AD509]	Word 509 is a discrete output in PC-700
[BD345]	Word 345 is a discrete output in PC-700
[BF22]	Word 22 is a discrete output in PC-700
[BO3]	Word 3 is a discrete output in PC-700
[BC254]	Word 254 is a discrete output in PC-900
[BS112]	Word 112 is a discrete output in PC-900
[CD18]	Word 18 is a discrete output in PC-900
[CR9]	Word 9 is a discrete output in PC-900
[DB255]	Word 255 is a discrete output in PC-1100
[DC123]	Word 123 is a discrete output in PC-1100
[EQ44]	Word 44 is a discrete output in PC-1100
[GE6]	Word 6 is a discrete output in PC-1100
[HR1500]	Word 1500 is a holding register
[IG16]	Word 16 is a discrete input in PC-700
[IR32]	Word 32 is a register input in PC-700
[IN5]	Word 5 is a discrete input in PC-900
[IM234]	Word 234 is a discrete output
[LS123]	Word 123 is a discrete output
[MB56]	Word 56 is a discrete output
[MR78]	Word 78 is a discrete output
[MV98]	Word 98 is a discrete output
[NL145]	Word 145 is a discrete output
[NR175]	Word 175 is a discrete output
[OG9]	Word 9 is a discrete output
[OR6]	Word 6 is a register output
[SB10]	Word 10 is a discrete output
[SK15]	Word 15 is a discrete output
[TR31]	Word 31 is a discrete output
[TS66]	Word 66 is a discrete output
[TT85]	Word 85 is a discrete output
[UC24]	Word 24 is a discrete output
[UI26]	Word 26 is a discrete output

### Bit References

<u>Reference</u>	<u>Description</u>
[IG2 14]	Bit 14 of input group 2
[BP14/IG2]	Bit 14 of input group 2
[IN0030]	Bit 30 of the input group (same reference as [IG2 14] and [BP14/IG2])
[CR0042]	Bit 42 of output group
[HR 1234 16]	Bit 16 of holding register 1234

## Access Permitted by Maintenance Template

The Maintenance Template will access all memory locations supported by the PLC driver as defined in this chapter. When running online, you may change the PLC reference. The Maintenance Template is designed to assist you in specifying the PLC reference by scrolling through a list of mnemonics which are used to enter the PLC word reference. When online in the PLC reference change mode, the following list is available.

"OG", "AD", "BD", "BF", "BO", "BC", "BS", "CD", "CR", "DB", "DC", "EQ"  
"GE", "IM", "LS", "MB", "MR", "MV", "NL", "NR", "SB", "SK", "TR", "TS"  
"TT", "UC", "UI", "OR", "HR", "IG", "IN", "IR", "BP", and "/"

You must enter the correct mnemonics and numeric values and create a legal reference to change a PLC reference. Once a new reference is entered, the Maintenance Template will remain in a paused state until the control button labeled "Start Monitor" is depressed. The PanelMate Series 1000 will then parse the reference. (Parsing means checking the syntax and range of the reference to ensure that it is supported by the driver.) If correct, the template begins updating.

# Appendix A

## Detailed Specifications

---

In this chapter, you will learn:

- Specific information about the PanelMate Series 1000

## Main Processor

---

CPU	Motorola 68340 micro controller
Clock Frequency	16 MHz

## Display

---

Type	LCD
Resolution	320 x 240 pixels (VGA-quality) monochrome

## Environment

---

Temperature	Operating Ambient: 0°-50°C Storage: -20°-60°C
Humidity	20-85% noncondensing
NEMA Class	NEMA 4 or NEMA 12 when properly mounted in a correspondingly rated enclosure NEMA 4X with the purchase of a Culter-Hammer IDT stainless steel housing option. Rated when properly mounted in a correspondingly rated stainless steel enclosure.
Vibration	Operating: 2g at 10-500 Hz Non-operating: 2g at 10-500 Hz
Shock	Operating: 15g Non-operating: 30g
Altitude	Operating: 10,000 feet above sea level Non-operating: 30,000 feet above sea level
Noise Immunity	NEMA ICS 2-230, showering arc test
Magnetic Field Influence	Proper operation up to 150 Gauss

## Power Requirements

---

Voltage	24V DC (18-30V DC)
Consumption	440 mA at 24V DC 500 mA at 24V DC with the Accelerat/On option

## Serial Port

---

Rate	Selectable; 110 to 19,200 baud Serial port is DB9S (Socket) Serial port is selectable for RS232 or RS422 signal levels
------	--

## Other

---

Weight	4 pounds 5 pounds with the Accelerat/On option
Equipment Heat Output	38 BTU/hr. (11 watts) 42 BTU/hr. (12 watts) with the Accelerat/On option



# Appendix B

## Configuration Creation Checklist

---

In this chapter, you will learn:

- Configuration Creation Checklist

# Configuration Creation Checklist

---

- \_\_\_\_\_ Determine the optional features of your PanelMate unit.  
Modicon Modbus Option Y or N  
DH-485 Option Y or N
- \_\_\_\_\_ Determine your PLC Brand and Model.
- \_\_\_\_\_ Review the Word and Bit References for the PanelMate unit's addressing.
- \_\_\_\_\_ Establish the data references inside the PLC. Group control bits, status bits and register information close together in PLC memory to reduce communication traffic.
- \_\_\_\_\_ Develop the strategy for Page usage. You may decide to group functionality on pages for the operator, for setup and for maintenance.
- \_\_\_\_\_ Develop a strategy for Page layout of the templates.
- \_\_\_\_\_ Create a scheme for use of the three visual attributes (normal, reverse, and blink) to indicate normal operating modes and fault conditions.
- \_\_\_\_\_ Use the worksheets compiled in Appendix F to gather the background information required to complete the spreadsheets for the templates.
- \_\_\_\_\_ Define requirements for International Fonts if applicable.
- \_\_\_\_\_ Develop your password protection scheme. Consider the following areas which can have password protection:
  - Page protection
  - Numeric Entry protection
- \_\_\_\_\_ Create your User Configuration on the DOS-base Configuration Software.
- \_\_\_\_\_ Download your configuration and PLC Driver to the PanelMate unit.
- \_\_\_\_\_ Connect to your PLC and test.

# Appendix C

## Installation Guidelines

---

In this chapter, you will learn:

- Physical Installation Considerations
- Environmental Considerations
- Wiring Considerations

## Overview

---

This document explains important considerations for installation of the PanelMate Series 1000.

## Physical Installation Considerations

---

Choosing where and how to mount your equipment is the first step in assuring its proper operation and long life.

The installation should protect your system from oil, dust, moisture, corrosive vapors, and other airborne contaminants. The front panel of the PanelMate Series 1000 provides a NEMA 4 or NEMA 12 rating when mounted in a correspondingly-rated enclosure. If you have purchased the NEMA 4X (stainless steel front panel) version of the PanelMate unit, it only provides this NEMA rating when mounted in a NEMA 4X enclosure.

When choosing an enclosure or mounting position, allow a good amount of free space around your unit. Leave at least two inches above and below the unit and one inch on either side. PanelMate units depend on this room to allow convection cooling of their interiors. Convection cooling draws a vertical column of air upward over internal circuitry through vents in the unit. This cooling air must not exceed 50°C (122°F). Placing a PanelMate unit on a horizontal surface blocks vents on the bottom of the unit, inhibiting convection cooling and causing damage to the unit.

Careful enclosure sizing is important for proper heat dissipation. Since other devices mounted in the same enclosure can also generate heat, consider the heat output of all equipment to be mounted in a given enclosure when choosing its size.

If the inside temperature of the enclosure is above the unit's recommended range (see table C-1), you can use filtered fans, heat exchangers, air conditioners, or switch to a larger enclosure to lower the temperatures. Keep in mind that your system will be more reliable and have a longer life if it is exposed to environmental conditions within the recommended range.

Since heat rises to the top of an enclosure, the temperature inside can vary greatly from the bottom to the top. A fan can be used to circulate air within the enclosure and maintain a more uniform temperature top-to-bottom.

Also remember to leave room for wiring, cabling connections, and access to the unit. Detailed panel cutout drawings are found in Chapter 5, Installation in an Industrial Enclosure, of this product manual for easy reference.

Your enclosure should be constructed of 14 or 16 gauge steel. This will help guard your unit against electromagnetic interference (your equipment is designed to meet IEEE specification ICS 2-230, showering arc test). It also provides good heat dissipation and proper structural support.

If an air-purged enclosure is used, it is recommended that the inside/outside pressure differential not exceed 0.5 PSI (13.8 inches water column). If needed, your unit can withstand a differential of up to 4.6 PSI (127 inches water column).

Never ship an enclosure with your unit mounted inside. This may seriously damage the equipment. Units should be shipped in their original packing material, then mounted in an enclosure when it reaches its final destination.

A table has been developed to help in your selection of a free-standing enclosure. It is based on the following assumptions: a 14 or 16 gauge cold rolled steel enclosure, 11 watts dissipated by the unit, no additional methods of cooling, the enclosure having all sides uninsulated and at least 2-inches between the unit and the top and bottom of the enclosure. From this chart, you can predict how much the internal temperature will rise with different size enclosures.

This table is offered to you as an aid in the selection of enclosures to be used with our product. Cutler-Hammer IDT offers no guarantee or warranty to the specific applicability of this table as actual conditions may vary and methods of the use of our product are beyond our control. The ultimate responsibility for the product's conformance to published specifications lies with you, the customer. For specific information about enclosure selection and cooling methods, contact your enclosure vendor.

<u>Enclosure Size vs. Internal Temperature Rise</u>	
Standard Enclosure Size (inches)	Internal Temperature Rise*
10x12x4	9.2°C
10x12x5	8.3°C
12x12x4	7.9°C
12x12x5	7.0°C

\*Accurate within 1/2°C assuming the PanelMate Series 1000 is the only equipment mounted in the enclosure.

Assumptions:

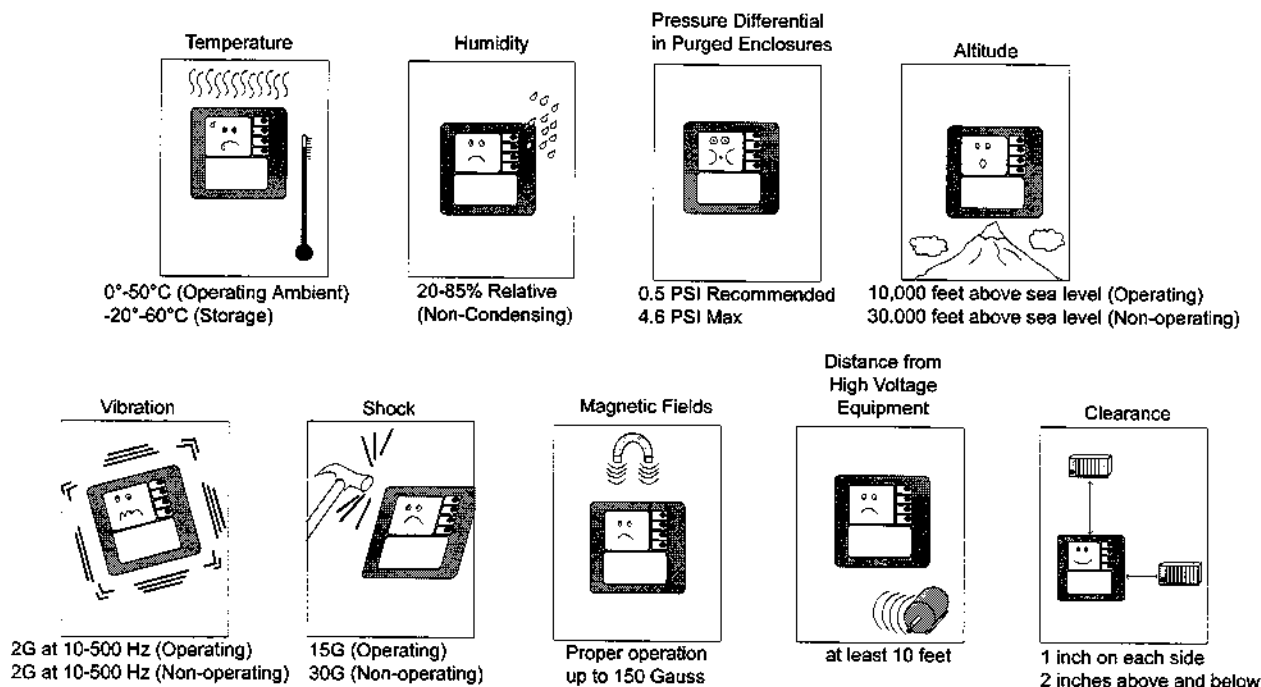
- 14 gauge cold rolled steel
- All sides uninsulated (free-standing)
- 2-inch clearance between PanelMate Series 1000 and the top and bottom of the enclosure.

**Table C-1 Heat Output Specification**

# Environmental Considerations

Cutler-Hammer IDT equipment is designed and tested to operate over a wide temperature range. Temperatures outside this range can severely shorten the life of your system. High humidity, vibration, shock, or altitude can also adversely affect your system's operation and lifespan.

See figure C-1 below for a list of environmental operating parameters for the PanelMate Series 1000.



**Figure C-1 Environmental Operating Parameters**

Locate your system as far as possible from transformers, relays, motor starters, and power or high-voltage (Type A) wiring. Maintain at least ten feet between your system and this type of equipment. This equipment generates interference which can induce noise in electrical wiring.

Line power provided to any electronic equipment should be relatively free of voltage drifts, spikes, and drop-outs. Spike suppressors, uninterruptable power supplies and other devices can be used to condition line voltage. Line frequency to AC to DC converters used to power the PanelMate unit should also be maintained within noted tolerances. All equipment should be properly grounded at a ground run separate from that used by high-power devices such as motor starters and arc welders.

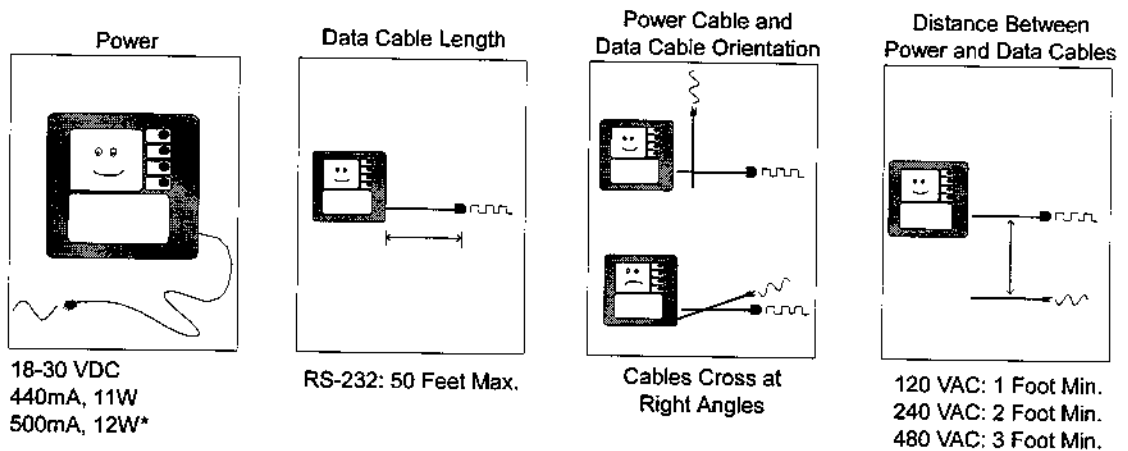
Cutler-Hammer IDT cannot advise nor accept liability regarding placement of our equipment in hazardous environments. If this is a requirement in your application, contact a vendor experienced in placing electronic equipment in hazardous environments.

# Wiring Considerations

Another important concern should be the proper installation of wiring or cabling for your unit. When planning the location and placement of wiring, make sure that high-power lines are not in close proximity to low-level signal or communication cables. High-power conductors (Type A) include AC power lines and high power AC or DC I/O lines, such as those which connect to hard-contact switches, relays, solenoids, motors, generators and arc welders. These generate a large amount of electrical noise which can interfere with the operation of your equipment.

Low-signal-level conductors (Type B) include those carrying serial communication and local area networks such as Ethernet and PLC networks. These have a low tolerance for induced electrical noise. All low-level wiring should be shielded and routed in a separate conduit or raceway from high-power wiring. All raceways and conduit must be properly grounded.

Route low-level conductors at least one foot from 120V AC power lines, two feet from 240V AC power lines, and three feet from 480V AC power lines. If a low-level conductor must cross high power lines, it should do so at a right angle.



\* with optional interface board

**Figure C-2 Power and Wiring Specifications**

Most RS232 serial communication cables should be limited to 50 feet in length. Some devices or high-noise environments may limit usable cable lengths to less than 50 feet. Longer lengths are generally possible if the total cable capacitance does not exceed 2500 picofarads.

The effects of electrical noise can be reduced by using shielded cables with twisted-pair conductors. This method uses one conductor of a twisted pair for the transmit data line and a second twisted pair for the receive data line. The second conductor (guard conductor) of each twisted pair is connected to signal ground at the receive end and left unconnected at the transmit end. Signal ground can be run by paralleling two conductors of a third twisted pair and using them as the single conductor ground return. If higher noise immunity and longer distances are required, RS422 or 20 mA current loop schemes should be used.

All cable shields should be connected at both ends. To achieve maximum immunity to high frequency noise, such as that produced by electrostatic discharge, the shield must be directly connected to the PanelMate enclosure at the cable entry point. A well shielded connector consisting of a metal shell cover is the best choice. **Never connect the shield to signal ground.** Always connect it to the metal shield housing of the cable connector. When assembling cables, be sure the shield contacts the metal connector housing cable entry hole uniformly around its entire 360° periphery. This is important because high frequency noise currents flow on surfaces. Discontinuities in the shield surface will resist and divert noise current along paths which may interfere with data signals.

If there is a significant AC or DC voltage difference (1 to 2 volts) between the power grounds of the PanelMate Series 1000 and a device to which it must be connected, then some type of electrical isolation (optical, fiber optical, or transformer) may be required.

Follow manufacturer's instruction for installation in local area networks and other communication cabling. High frequency communication often requires special cable and precautions to guard against signal reflections. External high-frequency disturbances near long cable runs may necessitate grounding cable shields at multiple points along the run.

# Appendix D

## Software Menu Hierarchy

---

In this chapter, you will learn:

- The Software Menu Hierarchy

# Editor Structure Hierarchy

---

## **Main Menu**

### **Develop a Configuration**

Edit an Existing Configuration

Create a New Configuration

Return to Main Menu

Configuration Editor

#### **Enter Directory Editor**

Directory Editor

(Page Titles, Password Selection)

Page Editor

Template Mode

(Indicator, Readout, Bar, Display, Table, Maintenance)

Message Library Editor

Save Page

Exit Page Editor

#### **Edit System Parameters**

(Audio, Status to/Control from PLC, Define Passwords)

#### **Edit PLC Name and Port Table**

(PLC type, name, serial port, scan rates)

#### **Edit System Online Labels**

#### **Print Documentation**

#### **Display Configuration**

#### **Select International Font**

#### **Merge Configuration**

#### **Save Configuration**

#### **Exit Configuration Editor**

### **Transfer Information**

Download Configuration to VCP Unit

Upload Configuration from VCP Unit

Download Driver Firmware to VCP Unit

Download Option to VCP Unit

Read System Information from the VCP Unit

Return to Main Menu

### **Perform File Management**

Copy a Configuration

Rename a Configuration

Delete a Configuration

Return to Main Menu

### **Configuration Verifier for Run Mode**

#### **Edit Utility Parameters**

(Directory Names/Paths, Autosaves/Backups)

#### **Display Help Page**

#### **Exit to DOS**

# Editor Structure Hierarchy with Key Chapter Cross Reference

<b>Main Menu</b> .....	<b>Chapter 11</b>
<b>Develop a Configuration</b> .....	<b>Chapter 12</b>
Edit an Existing Configuration	
Create a New Configuration	
Return to Main Menu	
Configuration Editor	
<b>Enter Directory Editor</b> .....	<b>Chapter 13</b>
Directory Editor	
Page Editor .....	<b>Chapter 14</b>
Template Mode	
Indicator .....	<b>Chapter 15</b>
Readout .....	<b>Chapter 16</b>
Bar .....	<b>Chapter 17</b>
Display .....	<b>Chapter 18</b>
Table .....	<b>Chapter 20</b>
Maintenance .....	<b>Chapter 21</b>
Message Library Editor .....	<b>Chapter 19</b>
Save Page .....	<b>Chapter 14</b>
Exit Page Editor .....	<b>Chapter 14</b>
<b>Edit System Parameters</b> .....	<b>Chapter 22</b>
(Audio, Status to/Control from PLC, Define Passwords)	
<b>Edit PLC Name and Port Table</b> .....	<b>Chapter 23</b>
(PLC type, name, serial port, scan rates)	
<b>Edit System Online Labels</b> .....	<b>Chapter 24</b>
<b>Print Documentation</b> .....	<b>Chapter 25</b>
<b>Display Configuration</b> .....	<b>Chapter 12</b>
<b>Select International Font</b> .....	<b>Chapter 12</b>
<b>Merge Configuration</b> .....	<b>Chapter 12</b>
<b>Save Configuration</b> .....	<b>Chapter 12</b>
<b>Exit Configuration Editor</b> .....	<b>Chapter 12</b>
<b>Transfer Information</b> .....	<b>Chapter 26</b>
Download Configuration to VCP Unit	
Upload Configuration from VCP Unit	
Download Driver Firmware to VCP Unit	
Download Option to VCP Unit	
Read System Information from the VCP Unit	
Return to Main Menu	
<b>Perform File Management</b> .....	<b>Chapter 27</b>
Copy a Configuration	
Rename a Configuration	
Delete a Configuration	
Return to Main Menu	
<b>Configuration Verifier for Run Mode</b> .....	<b>Chapter 6</b>
<b>Edit Utility Parameters</b> .....	<b>Chapter 9</b>
(Directory, Names/Paths, Autosaves/Backups)	
<b>Display Help Page</b> .....	<b>Chapter 9</b>
<b>Exit to DOS</b> .....	<b>Chapter 9</b>



# Appendix E

## International Font Characters

---

In this chapter, you will learn:

- How to access the International Font
- How to use recall keys to enter the characters
- The character cell representations

## Font Selection

---

Fonts are selected in the Configuration Editor Menu. Select the International Font by its DOS filename. The fonts available at the time of this printing are:

Danish1.FNT  
French1.FNT  
French2.FNT  
German1.FNT  
Spanish1.FNT  
Swedish1.FNT

The software will automatically install the 10 character cells in the normal font recall keys, ^v through ^\_. To enter the recall key, ^v, you must press the <Ctrl> <v> keys simultaneously.

## Font Character Cell Representation

---

The cross-reference for each recall key and font are shown in the the following figures.

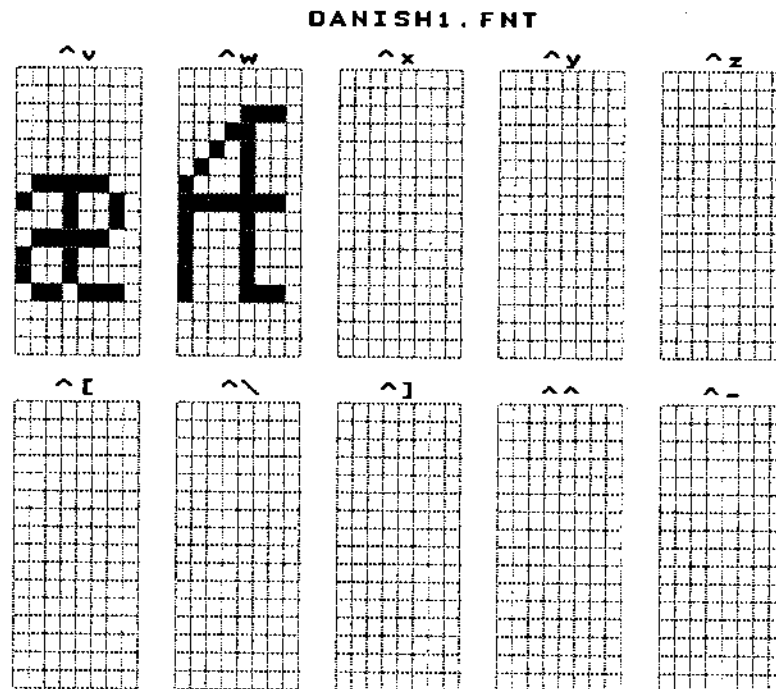


Figure E-1 Danish Font

FRENCH1.FNT

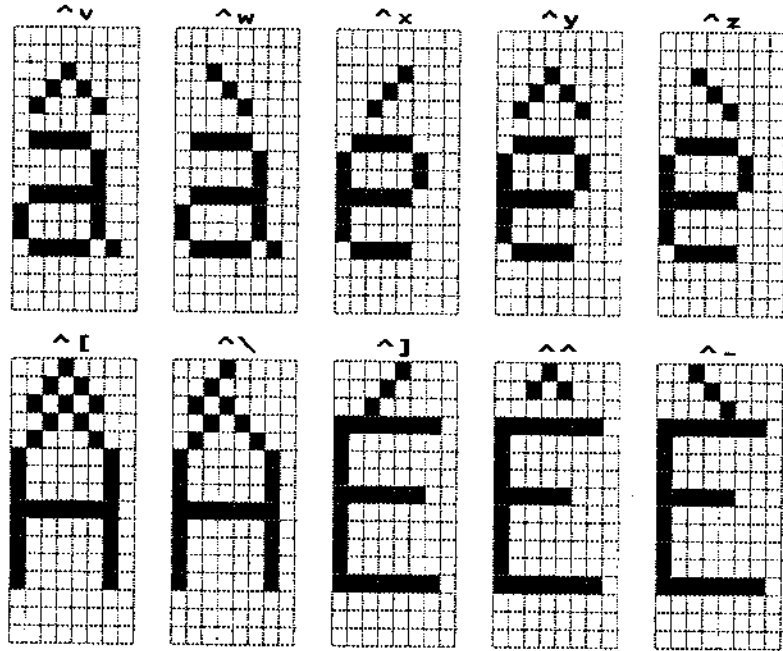


Figure E-2 French Font 1

FRENCH2.FNT

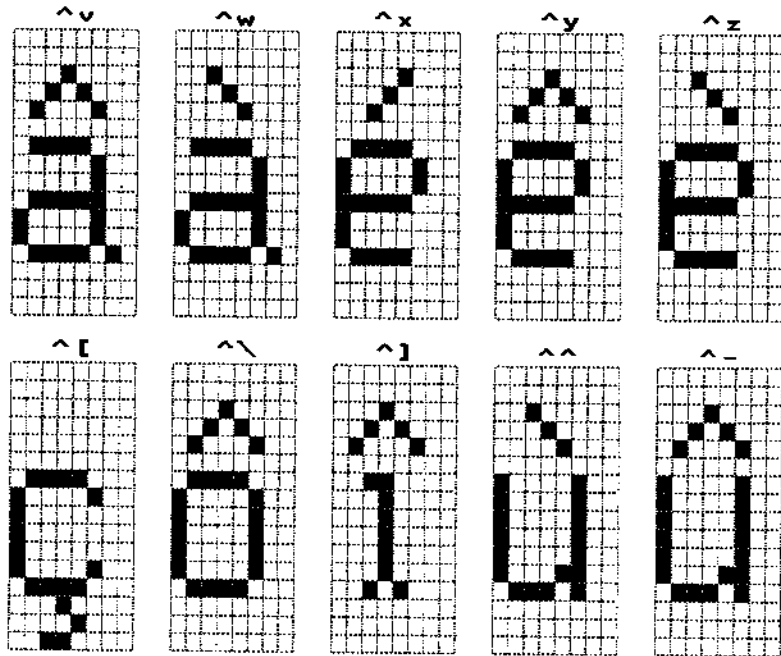
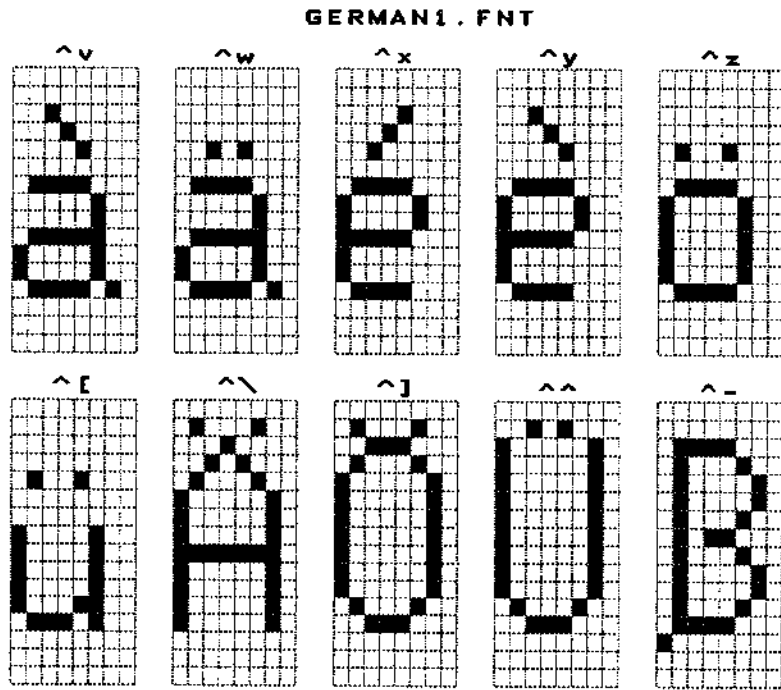
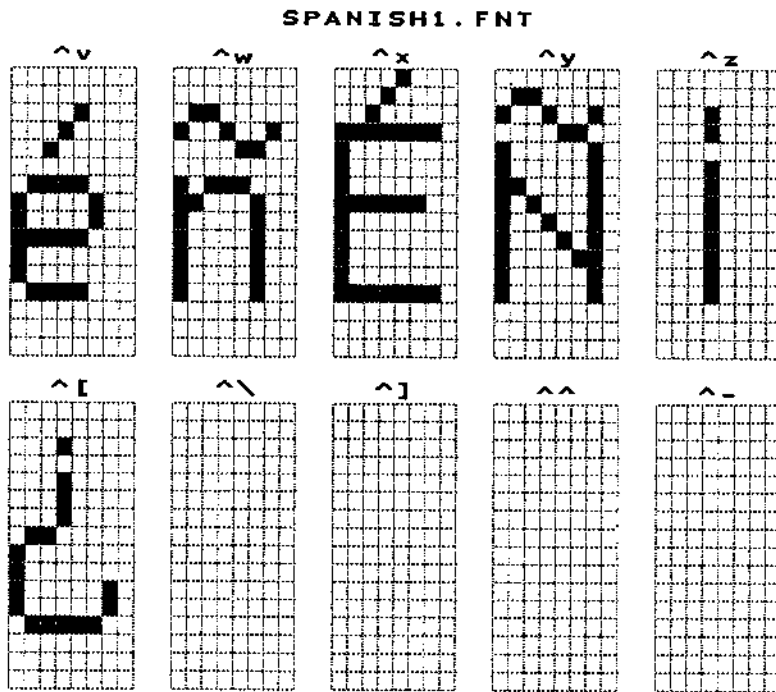


Figure E-3 French Font 2



**Figure E-4 German Font**



**Figure E-5 Spanish Font**

SWEDISH1.FNT

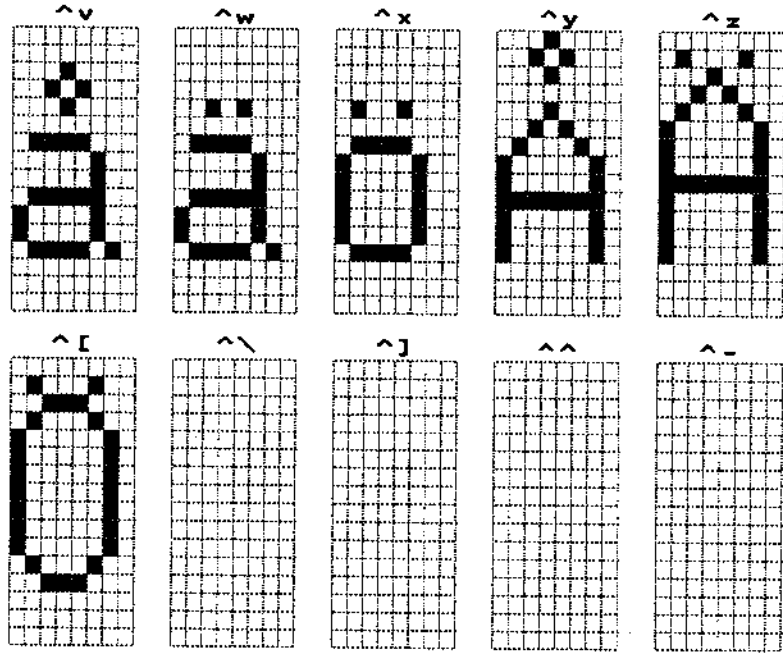


Figure E-6 Swedish Font



# Appendix F

## Worksheets

---

## INDICATOR TEMPLATE EDITOR

Template Size: NORMAL or DOUBLE-WIDE

Character Size: NORMAL or QUAD or DOUBLE-HIGH

Device Name (16 char): \_\_\_\_\_

Priority	Attr	Template Label (16 char)	PLC Bit Reference (70 char)	Alm	Ack
1					
2					
3					
4					
5					

Button	Attr	Control Label (16 char)	PLC Bit Reference (18 char)
1			
2			
3			
4			

**Note** Use <Ctrl> <m> to insert a carriage return in text fields.

## READOUT TEMPLATE EDITOR

Template Size/Character Size: NORMAL/NORMAL, NORMAL/QUAD,  
NORMAL/DOUBLE-HIGH, or DOUBLE-WIDE/QUAD

Decimal Places (0-8): \_\_\_\_\_

Decimal Name (16 char): \_\_\_\_\_

Value Expression (70 char): \_\_\_\_\_

High Alarm Expression (70 char): \_\_\_\_\_

Low Alarm Expression (70 char): \_\_\_\_\_

Deadband Range (0-99%): \_\_\_\_\_

Alarm Acknowledgement: \_\_\_\_\_

Control Type: NONE or NUMERIC or BUTTONS

If NUMERIC,

Target Word Address: \_\_\_\_\_

Password Protection    \_\_\_NONE    \_\_\_A    \_\_\_B    \_\_\_A or B

If BUTTONS,

Button	Attr	Control Label (36 char)	PLC Bit Reference (18 char)
1			
2			
3			
4			

**Note**    Use <Ctrl> <m> to insert a carriage return in text fields.

## BAR TEMPLATE EDITOR

Template Size: 2WIDE or 3WIDE

Device Name (16 char): \_\_\_\_\_

Units (3 char): \_\_\_\_\_

Maximum Calibration (6 char): \_\_\_\_\_

Minimum Calibration (6 char): \_\_\_\_\_

Actual Value Expression (70 char): \_\_\_\_\_

Setpoint Value Expression (70 char): \_\_\_\_\_

High Alarm Expression (70 char): \_\_\_\_\_

Low Alarm Expression (70 char): \_\_\_\_\_

Deadband Range (0-99%): \_\_\_\_\_

Alarm Acknowledgement: \_\_\_\_\_

Control Type: NONE or NUMERIC or BUTTONS

If NUMERIC,

Target Word Address (18 char): \_\_\_\_\_

Password Protection    \_\_\_NONE    \_\_\_A    \_\_\_B    \_\_\_A or B

If BUTTONS,

Button	Attr	Control Label (16 char)	PLC Bit Reference (18 char)
1			
2			
3			
4			

**Note**    Use <Ctrl> <m> to insert a carriage return in text fields.

## DISPLAY TEMPLATE EDITOR

Template Size: 2WIDE or 3WIDE

Line	Display Expression (70 char)	Test Message
1		
2		
3		

Button	Attr	Control Label (16 char)	PLC Bit Reference (18 char)
1			
2			
3			
4			

**Note** Use <Ctrl> <m> to insert a carriage return in text fields.





## MAINTENANCE TEMPLATE EDITOR

Template Size: NORMAL or DOUBLE-WIDE

Write privilege: READ/WRITE or READ ONLY

Default PLC Reference: \_\_\_\_\_

Data Format: Num, Bits, or Hex

Password Protection    \_\_\_NONE    \_\_\_A    \_\_\_B    \_\_\_A or B

# **Appendix G**

## **Notes for the User of other PanelMate Series Products**

---

# Notes for the User of other PanelMate Series Products

---

There are some features which define the functionality of the PanelMate Series 1000 product as compared to the PanelMate Series 2000, PanelMate Series 3000, and PanelMate Series 4000.

The following are features unique to the PanelMate Series 1000.

- 8 pages
- 100 Messages
- 6 Fixed Templates: Indicator, Readout, Bar, Display, Table, and the new Maintenance template
- Alarm indication is limited to "Page Alert". An alarm will cause the page number in the System Overview field to blink to indicate an alarm is present on that page. The alarm window is no longer displayed on every page, but there is an alarm summary page. The alarm message always includes the page number, template number, and the nature of the alarm (high alarm, low alarm, or the alarm condition label). The following attributes also apply to alarm messages, depending on the condition being reported:

New alarms	New alarms are displayed as blinking text.
Acknowledged	Acknowledged alarms are displayed as reversed video text. The abbreviation "Ackd" will appear in the message.
Cleared, not acknowledged	Cleared alarms that have not been acknowledged are displayed as normal text. The abbreviation "Clrd" will appear in the message.
Cleared and Acknowledged	The message will disappear from the screen. The message that gets sent to the printer will include the abbreviation "Clrd".

## Overview

---

The PanelMate Series 1000 is a base-level video control panel. It is a direct replacement for pushbuttons, pilot lights, thumbwheels, readouts, and message display units. As a base level product which replaces these low level devices, it requires the same level of PLC ladder logic programming support as the devices it replaces. A step up to the higher level products like the PanelMate Series 2000, PanelMate Series 3000, and PanelMate Series 4000 will provide additional functionality which will reduce the amount of PLC programming to develop an effective operator interface. The next items define specific product features which define the difference between the base-level functionality of the PanelMate Series 1000 and full-featured capabilities of the fixed templates in the PanelMate Series 2000, PanelMate Series 3000, and PanelMate Series 4000.

1. The PanelMate Series 1000 supports only fixed sized templates with three visual attributes: normal, reverse video, or blinking. The smaller screen size means that normal font label in the templates and control buttons are two-lines of eight characters each.

The PanelMate Series 2000, PanelMate Series 3000, and PanelMate Series 4000 support four-level gray scale or color, variable-sized templates, and graphics. Most labels are two-lines of eleven characters each.

**Note** The PanelMate Series 2000, PanelMate Series 3000, and PanelMate Series 4000 display more digits than the PanelMate Series 1000 in the readout, bar, and table templates. For example, if a normal single-wide Readout template is configured to display quad characters, the PanelMate Series 2000, PanelMate Series 3000, and PanelMate Series 4000 will display six digits, whereas the PanelMate Series 1000 will display only four digits. If displaying a unsigned 16 bit value, which has a maximum value of 65535 (i.e. a five digit value), the number will be displayed completely in a PanelMate Series 2000, PanelMate Series 3000, and PanelMate Series 4000, but only the four most significant digits will be displayed in a PanelMate Series 1000. (For example, if 65535 is reference in the template, the value 6553 will be displayed in a PanelMate Series 1000. In order to avoid improper display of the value, there are three possibilities which must be reviewed during configuration.

Ensure the value will never be greater than four digits (9999 maximum).

Modify the readout template to display in Normal font which shows 8 digits.

Modify the template to be double-wide/quad which will show up to 9 digits.

2. The Indicator template is configured with a single bit reference for each of the five display states. If control logic is required, then the PLC program must generate a specific bit to trigger a display state. One can use the tilde (~) to negate a value.

The PanelMate Series 2000, PanelMate Series 3000, and PanelMate Series 4000 permit full conditional expressions which allow logic to be implemented in the PanelMate unit. This capability can remove certain logic functions from the PLC program which requires additional programming and memory.

3. The Readout template can display one value. The value is read directly from the PLC with no data manipulation other than scaling by a factor of 10. The range includes multiplying by 1000 to dividing by 1000. You must enter the expression as [Reg]\*10. You must use the following scale factors: 1000, 100, 10, 1, .1, .01, or .001 . The text strings must be exact. You cannot have leading or trailing zeroes or extra spaces after the scale factor. Input values are configured in the Target Word Address and are sent directly to the PLC with the factor of 10 scaling permitted.

The PanelMate Series 2000, PanelMate Series 3000, and PanelMate Series 4000 permit two values in a readout template. One value can display the actual value and the second value can display the setpoint. Alternately, a unit's field may be displayed. The display values, input expression, and minimum and maximum alarms have full mathematical expressions. This permits manipulation and transformation of numbers in the PanelMate unit and removes work from the PLC.

4. Password protection in the PanelMate Series 1000 is based on permissive bits which are enabled and disabled by the PLC. The PanelMate Series 1000 can scan two separate bit values to determine if they are true or false to enable or disable passwords. All password entry and logic testing is performed in the PLC.

The PanelMate Series 2000, PanelMate Series 3000, and PanelMate Series 4000 manages one hardware security keyswitch and two software passwords without interaction with the PLC.

5. The Bar template is presented in the horizontal perspective across the page. Actual values and setpoint values are displayed directly from the PLC. Single point minimum and maximum range limits and alarming are designed in the software. Scaling by a factor of 10 is permitted for these values, although full logic expressions are not.

The PanelMate Series 2000, PanelMate Series 3000, and PanelMate Series 4000 display vertical bar templates and permit expressions to be defined to manipulate values, limits, and alarms.

6. The Display template permits up to 100 messages. The message number must be sent in the PLC register. Conditional expressions are not allowed. (For example, the use of bit references times a constant is not permitted.)

The PanelMate Series 2000, PanelMate Series 3000, and PanelMate Series 4000 permits more messages (up to 500) and the use of mathematical expression and logic to determine which message should be displayed.

7. The Table template in the PanelMate Series 1000 can be up to 20 items long. Scaling by a factor of 10 is permitted, although full mathematical expressions are not. The input value expression field has been combined into the Target Word Address which is where the scaling factor may be entered.

The PanelMate Series 2000, PanelMate Series 3000, and PanelMate Series 4000 permit up to 50 items per template and full mathematical expressions.

8. The Maintenance template is being introduced in the PanelMate Series 1000. The template is configured to allow an operator to dynamically define what PLC data to examine. The template is configured offline to be read only or read/write. Once online, the operator can make the following selections to display data: Change PLC name, PLC reference, and the data format. For example, the operator could ask to view PLC #2, see timer number six, and display the data in numeric format (Num). The term "Maintenance Template" has been defined for this advanced timer, counter, register, word, and bit access capability.

9. The PanelMate Series 1000 as a base-level product does not have time stamping. The PanelMate Series 2000, PanelMate Series 3000, and PanelMate Series 4000 have a built-in real-time clock and alarm table functionality to provide additional capability to the designer of the operator interface panel.

10. The System Parameter features for the PanelMate Series 2000, PanelMate Series 3000, and PanelMate Series 4000 are comparable to the System Parameter features for the PanelMate Series 1000 in table G-1 on the following page.
11. The PanelMate Series 1000 does not support unsolicited messages from PLCs.
12. The PanelMate Series 1000 is shipped with a self-contained demonstration program which illustrates basic product functionality. It demonstrates all the template page changes and the alarm page. The demonstration of the Maintenance Template permits change of the data format but does not permit changes to the PLC name or PLC reference. When entering numeric values, use a maximum of 999.  
The demonstration program cannot be uploaded from the PanelMate unit.
13. The PanelMate Series 1000 uses the same communication cable for downloading as the PanelMate Series 2000, PanelMate Series 3000, and PanelMate Series 4000. When power is applied to the PanelMate Series 1000, it immediately tries to enter the Run Mode. To enter the Transfer Mode, remove and re-apply power. Hold the <Cancel> key until the PanelMate unit enters the Offline Mode, then select the Transfer Mode.

System Parameter Features on the PanelMate Series 2000, PanelMate Series 3000, and PanelMate Series 4000	System Parameter Features on the PanelMate Series 1000
Audio Outputs on Operator Input	YES (on/off selection -- not a volume level)
Audio Outputs on Alarm	YES (on/off selection -- not a volume level)
Re-defined fonts	Only international font
Fault Relay	NO
Host Window	NO
Immediate Page Change	YES
Page Status Line	No choice, always shown. FIFO not permitted
Control Bit Reset	YES
Retry Delay	YES
Startup Page Number	YES
Inactivity Period Screen Blanking	NO (screen blanking is not required for LCD)
Inactivity Period Automatic Cancel	YES
Page Password Timeout	NO
Password A	Read Bit from PLC (Not stored in PanelMate unit)
Password B	Read Bit from PLC (Not stored in PanelMate unit)
Password A Overwrite	Not applicable
Password B Overwrite	Not applicable
Password for Offline Mode	Not applicable
Password for Set Date/Time	Not applicable
Enable Password Changes	Not applicable
Remote Alarm (to PLC)	YES
Acknowledge Bit (from PLC)	YES
Remote Silence (to PLC)	YES
Alarm Horn Bit (from PLC)	YES
Remote Enable (to PLC)	Not applicable
Fault Relay Bit (from PLC)	Not applicable
Remote Sending of Passwords	Not applicable
Password A	Not applicable, read bit from PLC
Password B	Not applicable, read bit from PLC
Hardware Selection (keyswitch)	Not applicable
Page Change (to PLC)	YES
Register (from PLC)	YES
Reset Clock to 00 bit	Not applicable

Table G-1 System Parameter Feature Comparison

# Index

---

## A

- A-B module for direct connection
  - 1771-KG, 29-18
  - 1775-KA, 29-18
- A-B module for PLC DH connection
  - 1771-KA, 1771-KA2, 29-14
  - 1775-KA, 29-15
  - 1785-KA, 29-15
- A-B module for PM unit DH connection
  - 1770-KF2 unit A, 1770-KF2 unit B, 29-17
  - 1771-KC, 1771-KD, 29-17
  - 1771-KE, 1771-KF, 29-16
- A-B module for PM unit to DH+ connection
  - 1770-KF2 series B, 29-19
  - 1785-KE series A, 29-20
  - 1785-KE series B, 29-20
- A-B module for PM unit to DH-485, 29-21
  - 1747-AIC, 29-21
- AcceleratI/On
  - Access permitted by maintenance template, 30-22
  - Active Racks, 30-14
  - Allen-Bradley word and bit references, 30-10
  - Block transfers, 30-15
  - Cabling, 30-7
  - Communication parameters, 30-8
  - Data highway and data highway plus, 30-10
  - Diagnostic indicators, 30-9
  - Possible configurations, 30-2
  - Remote I/O, 30-10
- Ack (acknowledge required), 15-5
- Active block transfer, 23-7
  - Direct, 23-7

- Group, 23-7
- Rack, 23-7
- Size, 23-8
- Slot, 23-8
- Alarm scan delay, 23-5
- Alarms, 6-7
- Allen-Bradley PLCs
  - Access permitted by maintenance template, 29-34
  - Memory, 29-2
  - Modules for direct connection, 29-18
  - Modules for PanelMate unit connections, 29-10
  - Modules for PLC data highway connection, 29-14
  - Modules for PM to data highway communication, 29-16
  - Modules for PM unit to data highway plus, 29-19
  - PLC-3 data access, 29-6
  - PLC-5 data access, 29-8
  - Possible configurations, 29-2
  - Serial cabling, 29-12
  - Serial communications parameters, 29-13
  - SLC 500 data access, 29-10
  - Unsolicited write message, 30-20
  - Word and bit references, 29-22
- Audio output, 22-5
- Audio output, problems, 8-2

## B

- Bar templates, 17-2
  - Actual value expression, 17-4
  - Alarm acknowledgment, 17-6
  - Control button definition table, 17-8
  - Control type, 17-6
  - Deadband range, 17-6

- Device name, 17-3
- Edit existing templates, 17-9
- Exit the bar template editor, 17-9
- Gathering information for configuration, 17-9
- High alarm expression, 17-5
- Low alarm expression, 17-5
- Maximum calibration, 17-4
- Minimum calibration, 17-4
- Numeric control definition, 17-7
- Setpoint value expression, 17-5
- Template size, 17-3
- Units, 17-4
- Basic steps for creating a user configuration, 10-1
- Basic steps for creating an application, 3-2
- Baud rate, 23-3
- Benefits, 2-2
- Binary-based formats, 19-5
- Block transfers
  - Discussions, 30-18
  - Examples, 30-16

## C

- Cable, transfer (pinout), 5-11
- Check system health, 4-3
  - Connect DC power, 4-5
  - Demonstration program, 4-5
  - Execute the system diagnostics, 4-6
  - Power up the unit, 4-5
- Communication errors, 6-10
- Configuration creation checklist, B-1
- Configuration editor menu, 12-4
  - Display configuration, 12-5
  - Edit PLC name and port table, 12-4
  - Edit system online labels, 12-4
  - Edit system parameters, 12-4
  - Enter directory mode, 12-4

- Exit configuration editor, 12-5
- Merge configuration, 12-5
- Print documentation, 12-4
- Save configuration, 12-5
- Select international font, 12-5
- Configuration Mode, 2-5
  - Cursor moves, 2-6
  - Cursors, 2-6
  - Error messages, 2-6
  - Field colors, 2-6
  - Function keys, 2-7
  - Special features, 2-5
- Configuration software
  - File naming conventions and file management, 9-4
  - Hardware requirements, 9-2
  - Non-VGA hardware, 9-4
  - Overview, 9-2
  - Running the setup installation program, 9-3
  - Starting, 9-4
- Connect DC power, 5-10
- Connect PanelMate unit to PLC, 10-4
- Connect PC to PanelMate, 5-11
- Connect printer to PanelMate, 5-11
- Contrast
  - Adjustment, 4-5, 6-6
- Control bit reset delay, 22-2
- Control button definition table
  - Attr, 15-5, 16-7, 17-8, 18-4
  - B (blink), 17-8
  - Control label, 15-6, 16-7, 17-8, 18-4
  - PLC bit reference, 15-6, 16-7, 17-9, 18-4
- Control buttons, problems, 8-2
- Control label, 15-6, 16-7, 17-8, 18-4
- Create a user configuration, 10-2

## Cutler-Hammer PLCs

- Access permitted by maintenance template, 31-12
- Cabling, 31-5
- Communications parameters, 31-6
- Memory, 31-2
- Possible configurations, 31-4
- Word and bit references, 31-10

## D

- Data bits, 23-3
- Data highway 485, 23-8
- Data highway and data highway plus, 30-10
- Deadband range, 16-4
- Decimal place formats, 19-5
- Decimal-based formats, 19-5
- Default PLC Name , 23-4
- Defining online labels, 24-2
- Defining system parameters, 22-2
- Demonstration program, 4-5
- Detailed specifications, A-1
- Develop configuration menu
  - Create new configuration menu, 12-3
  - Edit an existing configuration, 12-2
- Device name, 15-3, 16-3, 17-3
- Directory editor, 13-1
  - Accessing the page editor, 13-3
  - Before you start configuring pages, 13-2
  - Copy, 13-5
  - Delete, 13-5
  - Enter, 13-3
  - Exit, 13-5
  - Functions , 13-2
  - Memory free, 13-5
  - Move, 13-4
  - Page title, 13-4

Protection, 13-3

Swap, 13-4

Display configuration menu, 12-5

Display system info., 4-8

Display templates, 18-2

Control button definition table, 18-4

Editing existing templates, 18-4

Exiting the display template editor, 18-4

Gathering information for configuration, 18-5

Message expression, 18-3

Template type, 18-3

Test message, 18-3

Display tests, 4-7

Documentation, print, 25-2

## E

Editing standards, 2-10

Data fields, 2-10

Fonts, 2-11

Help pages, 2-11

Option window, 2-10

Editor structure hierarchy, D-2

Key chapter cross reference, D-3

Electrical (Elect), 23-4

Enclosure sizing, 5-2

Enhancing operator performance, 3-4

Error code descriptions, 6-14, 29-35 - 29-36

Errors

Communication, 6-10

Run mode, 6-10

System, 6-13

Execute tests, 4-6

## F

File management, 27-1

Copy a configuration, 27-2

- Delete a configuration, 27-4
- Menu, 27-2
- Rename a configuration, 27-3
- Return to main menu, 27-4
- Font character cell representation, E-2
- Font selection, E-2
- Fonts, International, 12-6, E-2
- Formatting data in messages, 19-6
- Formatting types, 10-7

## **G**

- Gathering information for configuration, 3-5
- General Electric PLCs
  - Access permitted by maintenance template, 32-44, 37-15, 38-10, 40-8
  - Cabling, 32-5
  - CCM2, 32-12
  - CCM3, 32-13
  - COM2, 32-6
  - Communications parameters, 32-9
  - I/O CCM, 32-13
  - Memory, 32-2
  - Possible configurations, 32-4
  - Switch settings, 32-10
  - Word and bit references, 32-15

## **H**

- Hardware checkout overview, 4-1
- Hardware description, 2-9
- Help page, 11-7
- High alarm expression, 17-5
- How to successfully develop your application, 3-1
  - Basic steps, 3-2
  - Defining the scope of the project, 3-2
  - Enhancing operator performance, 3-4
  - Gathering information for configuration, 3-5

- Page layout, 3-3
- How to use this manual, 1-2

## **I**

- ID# (PLC Name Table), 23-4
- Immediate page change, 22-2
- Indicator templates, 15-2
  - Character size, 15-3
  - Control button definition table, 15-5
  - Device name, 15-3
  - Editing existing templates, 15-6
  - Exit the indicator template editor, 15-6
  - Gathering information for configuration, 15-6
  - Template definition table, 15-3
  - Template size, 15-3
- Installation guidelines, C-1
- Installation in an industrial enclosure, 5-2, 5-10
  - Enclosure sizing, 5-2
- International Font Characters, E-1
- International Fonts, 12-6

## **K**

- Keypad tests, 4-6

## **L**

- Labels, 24-2
- Labels, change labels, 24-2
- Labels, startup online, 24-2
- Low alarm expression, 17-5

## **M**

- Main menu, 11-1 - 11-2
  - Develop a configuration, 11-2
  - Display help page, 11-7
  - Edit utility parameters, 11-4
  - Perform file management, 11-2

- Transfer information, 11-2
- Verify a configuration, 11-3
- Maintenance, 7-2
- Maintenance templates, 21-2
  - Data format, 21-4
  - Default PLC reference, 21-4
  - Edit existing templates, 21-4
  - Exit the bar template editor, 21-4
  - Gathering information for configuration, 21-5
  - Password protection, 21-4
  - Template size, 21-3
  - Write privilege, 21-3
- Manual organization, 1-3
- Memory transfers using the IBM personal computer, 26-4
- Merge configuration menu, 12-6
- Message library editor, 19-2
  - Attr (character attributes), 19-2
  - Char size (character size), 19-2
  - Exit the message library editor, 19-7
  - Gathering information for configuration, 19-7
  - Message text, 19-2
  - Msg# (message number), 19-2
  - Register references within messages, 19-3
  - Save, 19-7
- Message scan delay, 23-5
- Message text, 19-2
- Mitsubishi PLCs
  - Access permitted by maintenance template, 33-26
  - Cabling, 33-12
  - Communications parameters, 33-14
  - Memory, 33-2
  - Possible configurations, 33-10
  - Word and bit references, 33-19
- Model, 23-4
- Modicon PLCs using Modbus
  - 484 PLC/J474 Modbus Communication Interface, 34-9
  - 884 Modbus Ports, 34-6
  - 984 and 584 Modbus Ports, 34-5
  - Access permitted by maintenance template, 34-14
  - Adapters, 34-3
  - Cabling, 34-4
  - Communications parameters, 34-5
  - Memory, 34-2
  - Micro 84/J375 Modbus Adapter, 34-7
  - Possible configurations, 34-2
  - Word and bit references, 34-11
- Monitor
  - Contrast adjustment, 4-5, 6-6
- Monitor, problems, 8-2
- N**
- Name, 23-4
- Notes for User of other PanelMate Products, G-2
  - Overview, G-2
- Numeric control definition
  - Password protection, 16-6, 17-7
  - Target word address, 16-6, 17-7
- O**
- Offline Mode, 4-6
- Omron PLCs
  - Access permitted by maintenance template, 35-13
  - Cabling, 35-6
  - Communications parameters, 35-8
  - Memory, 35-2
  - Possible configurations, 35-5
  - Word and bit references, 35-11
- Online operation, 6-1, 10-5
- Operator input, 6-7
- Operator performance, enhancing, 3-4

## Overview

- Benefits, 2-2
- Editing standards, 2-10
- Hardware description, 2-9
- Product description, 2-4

## P

- Page change register, 22-2, 22-4
- Page editor, 14-1
  - Configuring, 14-2
  - Exit the page editor, 14-7
  - Main menu, 14-3
  - Message mode, 14-7
  - Page layout, 14-2
  - Save the page, 14-7
  - Template mode, 14-3
- Page editor in template mode, 14-3
  - Add a template, 14-4
  - Copy a template, 14-5
  - Delete a template, 14-5
  - Edit a template definition, 14-4
  - Exit the template mode, 14-6
  - Memorize or recall a template, 14-6
  - Move a template, 14-4
  - Save, 14-6
- Page layout, 3-3
- Page number, startup, 22-5
- Page, call a new, 6-6
- Page, PLC selection, 6-6
- Page, save, 14-6
- PanelMate Series 1000 cutout and torque limit, 5-4
- PanelMate Series 1000 outline, 5-3
- PanelMate Series 1000 rear view, 5-5
- Parity, 23-3
- Password protection, 6-9
- Passwords, 22-3
- Personal computer
  - connecting, 5-11
- PLC bit reference, 15-6, 16-7, 17-9, 18-4
- PLC name and port table, 23-2, 23-4
  - Alarm scan delay, 23-5
  - Baud rate, 23-3
  - Data bits, 23-3
  - Default PLC name field, 23-4
  - Electrical, 23-4
  - ID# (PLC name table), 23-4
  - Message scan delay, 23-5
  - Name, 23-4
  - Network ID#, 23-3
  - Parity, 23-3
  - Screen scan delay, 23-5
  - Stop bits, 23-3
  - Use, 23-2
- PLC register formats, 10-7
- Port, (pinout), 5-11
- Power connections, 5-10
- Power-up sequence, 6-2
  - Execute normal power-up diagnostics, 6-2
  - Run mode initialization, 6-3
- Print documentation, 25-2
- Problems
  - Audio output, 8-2
  - Control buttons, 8-2
  - Monitor, 8-2
  - Serial port, 8-3
  - Specific error messages, 8-4
  - TouchPanel, 8-2
  - Transferring memory, 8-3
- Product description, 2-4
  - Configuration mode, 2-5
  - DOS-based configuration software, 2-5

PanelMate online system, 2-4

Run mode, 2-8

System overview field, 2-9

Template mode, 2-7

## **R**

Readout templates, 16-2

Alarm acknowledgment, 16-5

Character size, 16-3

Control button definition table, 16-6

Control type, 16-5

Deadband range, 16-4

Decimal places, 16-3

Device name, 16-3

Editing existing templates, 16-7

Exit the readout template editor, 16-7

Gathering information for configuration, 16-7

High alarm expression, 16-4

Low alarm expression, 16-4

Numeric control definition, 16-5

Templates size, 16-3

Value expression, 16-3

Register references within messages, 19-3

Binary-based formats, 19-5

Decimal place formats, 19-5

Decimal-based formats, 19-5

Regular maintenance, 7-2

Reliance PLCs

Access permitted by maintenance template, 36-9

Cabling, 36-5

Communications parameters, 36-5

Memory, 36-2

Possible configurations, 36-3

Word and bit references, 36-8

Remote alarm acknowledge, 22-4

Remote I/O, 30-10

Active block transfer, 30-12

Control button reset delay, 30-14

Monitor block transfer, 30-13

Monitored I/O, 30-11

Remote I/O configuration, 23-6

Active block transfer table, 23-7

Active rack table, 23-7

Remote silence alarm horn bit, 22-4

Run mode, 2-8, 6-4

Adjusting the contrast, 6-6

Alarm page, 6-8

Alarms, 6-7

Call a new page, 6-6

Default control button labels, 6-5

Entering, 4-8

Errors, 6-10

Operator input, 6-7

Page title line, 6-4

PLC page selection, 6-6

System overview, 6-4

## **S**

Scan delay

Alarm, 23-5

Message, 23-5

Screen, 23-5

Screen blanking inactivity period, 22-5

Screen scan delay, 23-5

Serial port, problems, 8-3

Serial printer

Connecting, 5-11

Siemens PLCs

Cabling, 37-5

Communications parameters, 37-5

Memory, 37-2

Possible configurations, 37-4

- Word and bit references, 37-6
- Software menu hierarchy, D-2
- Specific error messages, 8-4
- Specifications, A-1
- Square D PLCs
  - Cabling, 38-3
  - Communications parameters, 38-4
  - DIP Switches, 38-5
  - Memory, 38-2
  - Possible configurations, 38-2
  - Thumbwheel Switches, 38-5
  - Word and bit references, 38-8
- Startup page number, 22-5
- Stop bits, 23-3
- System errors, 6-13
- System health, check, 4-3
- System Information
  - Read, 26-14
- System online labels, 24-2
  - Alarm text, 24-5
  - Change online labels, 24-2
  - Error messages, 24-4
  - Maintenance template soft key prompts, 24-4
  - Miscellaneous soft key prompts 1, 24-3
  - Miscellaneous soft key prompts 2, 24-3
  - Miscellaneous text, 24-5
  - Startup online labels, 24-2
- System overview, 6-4
- System overview field, 2-9
- System parameters, 22-2
  - Audio output, 22-5
  - Control bit reset, 22-2
  - Exit, 22-5
  - Immediate page change, 22-2
  - Inactivity periods, 22-5

- Page change register, 22-4
- PanelMate Series feature comparison, G-6
- Passwords, 22-3
- Remote alarm acknowledge, 22-4
- Remote silence alarm horn bit, 22-4
- Retry delay, 22-3
- Startup page number, 22-5

## T

- Table templates, 20-2
  - Current value tag, 20-3
  - Dec. pt., 20-5
  - Device name, 20-3
  - Edit value tag, 20-3
  - Editing existing templates, 20-5
  - Exit the table template editor, 20-5
  - Gathering information for configuration, 20-5
  - Parameter column, 20-4
  - Parameter tag, 20-3
  - Password protection, 20-3
  - Table entry definition table, 20-4
  - Target word address column, 20-5
  - Template size, 20-3
  - Value expression column, 20-4
- Target word address, 16-6, 17-7
- Template definition table
  - Ack, 15-5
  - Alm (Alarm), 15-5
  - Attr, 15-4
  - Conditional expression, 15-4
  - Template label, 15-4
- Template mode, 2-7
- Tests
  - Display, 4-7
  - Keypad, 4-6
  - Serial port, 4-6

- Watch dog, 4-7
  - Texas Instruments PLCs
    - Access permitted by maintenance template, 39-26
    - Cabling, 39-6
    - Communications parameters, 39-7
    - Data communication module TI 405 series, 39-10
    - Data communication unit TI 305 series, 39-12
    - Dual communication port module TI 500 series, 39-7
    - Memory, 39-2
    - Possible configurations, 39-5
    - Word and bit references, 39-20
  - TouchPanel, problems, 8-2
  - Transfer editor, 26-1
    - Download configuration, 26-4
    - Download driver firmware, 26-9
    - Download option, 26-12
    - Preparing to transfer, 26-3
    - Read system information, 26-14
    - Return to main menu, 26-14
    - Transfer information menu, 26-4
    - Upload configuration, 26-7
  - Transfer files to PanelMate unit, 10-4
  - Transfer mode
    - Entering, 4-7
  - Transferring memory, problems, 8-3
  - Troubleshooting guide, 8-1
    - Audio output problems, 8-2
    - Control button problems, 8-2
    - Monitor problems, 8-2
    - Serial port problems, 8-3
    - Specific error messages, 8-4
    - TouchPanel problems, 8-2
    - Transferring memory problems, 8-3
  - Troubleshooting the configuration software, 28-1
    - Disk access error messages, 28-4
    - File name error messages, 28-6
    - Help page error messages, 28-4
    - Miscellaneous error messages, 28-2
    - Program/file load error messages, 28-3
    - Startup error messages, 28-2
  - Typographical conventions, 1-3
- U**
- Unpacking, 4-2
  - User configuration
    - Connect PanelMate unit to your PLC, 10-4
    - Creating, 10-2
    - Develop configuration menu, 12-2
    - Online operation, 10-5
    - Overview, 10-2
    - Transferring files, 10-4
  - Utility Parameters, 11-4
- V**
- Verify a Configuration, 11-3
- W**
- Watch dog test, 4-7
  - Westinghouse PLCs
    - Cabling, 40-3
    - Communications parameters, 40-4
    - Memory, 40-2
    - Possible configurations, 40-3
    - Word and bit references, 40-5
  - Word and bit references, 10-7
  - Worksheets, F-1



# Cutler-Hammer IDT Reader Comment Card

Cutler-Hammer IDT strives to provide quality product manuals and training manuals. Please take a moment and tell us what you think about this manual.

## How do you use this document?

- |  |  |
|--|--|
| <input type="checkbox"/> Introduction to the product | <input type="checkbox"/> Installation Instructions |
| <input type="checkbox"/> Classroom resource          | <input type="checkbox"/> Reference                 |
| <input type="checkbox"/> Self-study/Tutorial         | <input type="checkbox"/> Other _____               |

## Please rate this document.

		Excellent	Very Good	Good	Fair	Poor
<b>Technical Accuracy</b>	Does the system work the way it is described in the manual?	<input type="checkbox"/>	<input type="checkbox"/>	<input type="checkbox"/>	<input type="checkbox"/>	<input type="checkbox"/>
<b>Readability</b>	Is the manual easy to read and understand?	<input type="checkbox"/>	<input type="checkbox"/>	<input type="checkbox"/>	<input type="checkbox"/>	<input type="checkbox"/>
<b>Clarity</b>	Are the instructions easy to follow?	<input type="checkbox"/>	<input type="checkbox"/>	<input type="checkbox"/>	<input type="checkbox"/>	<input type="checkbox"/>
<b>Examples</b>	Are the examples helpful and realistic? Are there enough examples?	<input type="checkbox"/> <input type="checkbox"/>	<input type="checkbox"/> <input type="checkbox"/>	<input type="checkbox"/> <input type="checkbox"/>	<input type="checkbox"/> <input type="checkbox"/>	<input type="checkbox"/> <input type="checkbox"/>
<b>Organization</b>	Is the organization of the manual logical? Is it easy to find what you are looking for?	<input type="checkbox"/> <input type="checkbox"/>	<input type="checkbox"/> <input type="checkbox"/>	<input type="checkbox"/> <input type="checkbox"/>	<input type="checkbox"/> <input type="checkbox"/>	<input type="checkbox"/> <input type="checkbox"/>
<b>Illustrations</b>	Are the illustrations clear and useful?	<input type="checkbox"/>	<input type="checkbox"/>	<input type="checkbox"/>	<input type="checkbox"/>	<input type="checkbox"/>
<b>Physical Attractiveness</b>	What did you think of the layout, printing, binding, etc.?	<input type="checkbox"/>	<input type="checkbox"/>	<input type="checkbox"/>	<input type="checkbox"/>	<input type="checkbox"/>

Are there any terms or concepts that are not defined clearly?  
If so, what are they?  Yes  No

\_\_\_\_\_

\_\_\_\_\_

After reading this document, are you able to use the equipment?  
If not, why?  Yes  No

\_\_\_\_\_

What errors did you find in this manual? (Please include page numbers. Attach an extra sheet if necessary.)

\_\_\_\_\_

Do you have any comments or suggestions? \_\_\_\_\_

\_\_\_\_\_

Name \_\_\_\_\_ Phone ( ) \_\_\_\_\_

Company \_\_\_\_\_

Manual Part Number: **01-00141-04** Manual Title: **PanelMate Series 1000 Product Manual**

Note that you may fax the Reader Comment Card to the Cutler-Hammer IDT Technical Publications Department at (614) 895-7111.

Thank You

FOLD ALONG LINE



NO POSTAGE  
NECESSARY  
IF MAILED  
IN THE  
UNITED STATES

**BUSINESS REPLY MAIL**

FIRST CLASS

PERMIT NO.228

WESTERVILLE, OHIO

POSTAGE WILL BE PAID BY ADDRESSEE

Cutler-Hammer IDT  
Technical Publications Department  
P.O. Box 6166  
Westerville, OH 43086-6166



FOLD ALONG LINE