

Cutler-Hammer 1570KHX

PanelMate Power Series Operator Station



\$3495.00

In Stock

Qty Available: 1

Used and in Excellent Condition

Open Web Page

<https://www.artisantg.com/84686-2>



Your **definitive** source
for quality pre-owned
equipment.

Artisan Technology Group

(217) 352-9330 | sales@artisanng.com | artisanng.com

All trademarks, brandnames, and brands appearing herein are the property of their respective owners.

- Critical and expedited services
- In stock / Ready-to-ship
- We buy your excess, underutilized, and idle equipment
- Full-service, independent repair center

Artisan Scientific Corporation dba Artisan Technology Group is not an affiliate, representative, or authorized distributor for any manufacturer listed herein.

**PanelMate Power Series
PanelMate PC
Getting Started
User's Guide**

Cutler-Hammer
173 Heatherdown Drive
Westerville, OH 43086-6166



The information contained in this manual is the property of Cutler-Hammer, Inc. Information in this manual is subject to change without notice and does not represent a commitment on the part of Cutler-Hammer, Inc.

Any Cutler-Hammer software described in this manual is furnished under a license agreement. The software may be used or copied only in accordance with the terms of the agreement. It is against the law to copy the software on any medium except as specifically allowed in the agreement. No part of this manual may be reproduced or transmitted in any form or by any means, electronic, mechanical, photocopying, recording or otherwise, without prior written permission of Cutler-Hammer, Inc.

RESTRICTED RIGHTS LEGEND

Use, duplication, or disclosure by the Government is subject to restrictions set forth in paragraph (b)(3)(B) of the Rights in Technical Data and Computer Software clause of DAR 7-104.9(a). Contractor/Manufacturer is Cutler-Hammer, P.O. Box 6166, Westerville, OH 43086-6166.

TRADEMARKS

AcceleratI/On is a trademark of Cutler-Hammer, Inc.
TouchPanel is a trademark of Cutler-Hammer, Inc.
PowerBlink is a trademark of Cutler-Hammer, Inc.
PowerAnimation is a trademark of Cutler-Hammer, Inc.
PowerGraphics is a trademark of Cutler-Hammer, Inc.
PanelMate is a registered trademark of Cutler-Hammer, Inc.
Microsoft and Windows are registered trademarks of Microsoft Corporation.
Modbus and Modbus Plus are trademarks of Schneider Automation Inc.
Remote I/O, DH-485, Data Highway, and Data Highway Plus are trademarks of Allen-Bradley Company, Inc.
GENius I/O is a trademark of GE Fanuc Automation North America, Inc.
DCS-NET is a trademark of Reliance Electric Company.
Adobe and Acrobat are trademarks of Adobe Systems Incorporated.

Commercial names of products from other manufacturers or developers that appear in this manual are registered or unregistered trademarks of those respective manufacturers or developers, which have expressed neither approval nor disapproval of Cutler-Hammer products.

Copyright Cutler-Hammer, Inc. 1999. All rights reserved.

P/N 01-00397-00

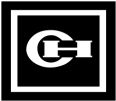

Table of Contents

Preface	I
PanelMate Power Series/PC Documentation.....	II
About This Manual.....	III
Purpose.....	III
What's Inside	III
Support Services.....	IV
Chapter 1. PanelMate Power Series/PC Features	1
PanelMate Power Series/PC Features.....	2
Using the Rest of this Manual	4
Chapter 2. How PanelMate Operator Stations Work Online	5
What Role a PanelMate Operator Station Plays in Factory Automation	6
How the PanelMate Operator Station Partners with a PLC	10
How Operators Interact with the PanelMate Operator Station	12
Standardized On-screen Tools Called "Templates"	14
Advanced Graphics Tools	16
Alarm Annunciation Capability.....	18
Additional Features Available	19
Organizing Multiple Pages for Best Operator Use	20
Chapter 3. From Opening the Boxes to Running Online: A Master Startup	
Flowchart.....	21
The Master Startup Flowchart	22
Chapter 4. Installing the Configuration Software	23
System Requirements	24
Running the Setup Program to Install the Software.....	26
Chapter 5. Creating a New Configuration.....	29
The Configuration Editor Main Screen	30
Starting a New Configuration.....	31
Chapter 6. Assigning Communications.....	33
Determining Communication Information.....	34
Configuring the PLC Name and Port Table.....	35
Configure Port Parameters Information.....	36
Configuring the PLC/Controller Processor.....	38



Configure PLC Name Parameter Information	39
Chapter 7 Creating New Pages	41
Using the Database Treeview Window	42
Creating New Pages (screens)	43
Creating a Page.....	44
Opening a Page.....	45
How to Configure a Template	46
How to Configure a Variable-Sized Template	49
How to Edit and Use the Message Library	50
How to Add PowerGraphics to a Page	51
Creating Symbols	53
How to Make PowerGraphics Change Dynamically	54
Chapter 8. Saving a Configuration	55
Saving Changes	56
Optimizing the Performance of your Personal Computer.....	57
Chapter 9. Exporting a Configuration	59
Exporting a Configuration	60
Chapter 10. Power Up the PanelMate Operator Station	61
Power Up the PanelMate Operator Station.....	62
Offline Mode Menu.....	63
Execute Diagnostics.....	64
Enter the Serial Transfer Mode.....	68
Enter Network Transfer Mode	69
Display System/Config. Information.....	70
Enter Run Mode.....	71
Calibrate Touchscreen	72
Chapter 11. Transferring a Configuration.....	73
Transfer Overview.....	74
Starting the Transfer Screen	75
Setting up the Computer Communication Parameters	76
Determining System Information	77
Selecting the Executive Firmware to Transfer.....	78
Selecting the Communication Drivers to Transfer	79
Selecting Options to Transfer.....	80
Selecting the Configuration to Transfer.....	81
Preparing the PanelMate Operator Station for a Transfer	82
Starting the Transfer Process.....	83



Chapter 12. Running a Configuration.....85
 Running a PanelMate Power Series Configuration.....86
 Running a PanelMate PC Configuration87

Chapter 13. Converting a Configuration89
 How to Convert A Configuration90
 Converting A Configuration90
 Conversion Considerations.....92
 Setting the High Capacity Unit Feature92
 Setting the Color Display Feature93
 Converting to PanelMate Power Series 1500.....94
 Converting to PanelMate Power Series 4000, PanelMate Power Series 5000,
 and PanelMate PC.....94
 Converting from PanelMate Power Series 4000, PanelMate Power Series 5000,
 and PanelMate PC.....94
 Converting Grayscale to Color95
 Copy & Paste, Drag & Drop95

Appendix A. Troubleshooting Guide97
 Problems with the Display.....98
 Problems with the Touchscreen.....98
 Problems with the Keypad.....98
 Problems with the Control Buttons.....99
 Problems with the Serial Port99
 Problems with Audio Output100
 Problems with the Fault Relay.....100
 Problems with a Printer101
 Problems when Transferring Memory102
 Problems with the Real-Time Clock.....102
 Communications Problems using the Generic Protocol.....102
 Specific Error Messages103





Preface

Welcome to Cutler-Hammer's PanelMate Power Series/PC Getting Started User's Guide. This chapter describes other PanelMate Power Series/PC documentation, describes the contents of this manual, and provides information on Support Services.



PanelMate Power Series/PC Documentation

The documents listed below are furnished with the PanelMate Power Series and PanelMate PC configuration software.

Getting Started User's Guide	Provides overview "tour" of the process from out of the box to running online.
Configuration Editor User's Guide	Provides enhanced copies of configuration software "Help" pages for lookup help on using functions.
Online Operation User's Guide	Provides descriptions of Run Mode features defined in the configuration software for the PanelMate Power Series.
Runtime Operation User's Guide	Provides descriptions of Run Mode features defined in the configuration software for the PanelMate PC.
Communication Driver Manuals	Provides descriptions of all setup information related to DDE Servers or to particular PLCs: cabling, networking, file types, addressing conventions, etc.

The documentation is provided in electronic files (*.PDF format) on CD-ROM. The electronic files can be accessed by using Adobe Acrobat. See the Install.txt file on the CD-ROM for instructions on locating the electronic documentation files and for a downloadable copy of Adobe Acrobat.

Note that printed manuals are available for purchase. (A printed copy of the Getting Started User's Guide is already provided with the PanelMate Power Series/PC configuration software.)



About This Manual

Purpose

This manual focuses on developing a configuration for a PanelMate Power Series/PC operator station using the Configuration Editor.

What's Inside

This manual is organized in the following way:

Preface

Chapter 1: For Previous Users of the PanelMate Series

Chapter 2: How PanelMate Operator Stations Work Online

Chapter 3: From Opening the Boxes to Running Online: A Master Startup Flowchart

Chapter 4: Installing the Configuration Software

Chapter 5: Creating a New Configuration

Chapter 6: Assigning Communications

Chapter 7: Creating New Pages

Chapter 8: Saving a Configuration

Chapter 9: Exporting a Configuration

Chapter 10: Power Up a PanelMate Operator Station

Chapter 11: Transferring a Configuration

Chapter 12: Running a Configuration

Chapter 13: Converting a Configuration

Appendix A: Troubleshooting Guide



Support Services

It is Cutler-Hammer's goal to ensure your greatest possible satisfaction with the operation of our products. We are dedicated to providing fast, friendly, and accurate assistance. That is why we offer you so many ways to get the support you need. Whether it's by phone, fax, modem, or mail, you can access Cutler-Hammer support information **24 hours a day, seven days a week**. Our wide range of services include:

Technical Support **1-800-809-2772**

If you are in the U.S. or Canada, you can take advantage of our toll-free line for technical assistance with hardware and software product selection, system design and installation, and system debugging and diagnostics. Technical support engineers are available for calls during regular business hours (8 am - 5:30 pm EST) by calling 1-800-809-2772. International calls can be made to either the Tech Line at 1-800-809-2772 (toll call) or the Cutler-Hammer main business line at 614-882-3282.

Emergency Technical Support **1-800-809-2772**

Because machines do not run on a nine-to-five schedule, we offer emergency after-hours technical support. A technical support engineer can be paged for emergencies involving plant down situations or safety issues. Emergency support calls are automatically routed directly to our answering service after-hours (5:30 pm - 8 am EST) and weekends. For emergency technical support, call 1-800-809-2772.

Note that the Emergency Technical Support phone number does not currently support product repairs or shipping outside normal business hours.

Technical Support Fax **614-882-0417**

You can also contact our technical support engineers by faxing your support requests directly to the Advanced Product Support Center (APSC) located in Westerville, Ohio at 614-882-0417.

Information Fax-Back Service **614-899-5323**

The latest Cutler-Hammer product information, specifications, technical notes and company news is available to you via fax through our direct document request service at 614-899-5323. Using a touch-tone phone, you can select any of the info faxes from our automated product literature and technical document library, punch in a fax number and receive the information immediately.



Web site and E-mail Address

**<http://www.cutlerhammer.eaton.com/automation>
chatechsupport@ch.etn.com**

If you have Internet capabilities, you also have access to technical support via our Web site at <http://www.cutlerhammer.eaton.com/automation>. The Web site includes technical notes, frequently asked questions, release notes, and other technical documentation. This direct technical support connection lets you request assistance and exchange software files electronically.

Technical support messages can also be sent to chatechsupport@ch.etn.com

Bulletin Board Service **614-899-5209**

Parameters: 8 data bits, 1 stop bit, parity none, 9600-28.8K baud.

If you have modem access, you can dial in directly to our electronic bulletin board service for the latest product and company information. File sharing, product software downloads and our user message service are just a few of the things you will find online at 614-899-5209.

Software Update Service **1-800-809-2772**
FAX 614-899-4141

We also offer you the opportunity to take advantage of software upgrades, advanced software notices, and special software promotions through our Software Update Service. When you register your software, you will receive one-year of free or reduced-price upgrades along with all the other benefits of membership, including 48-hour shipping of software upgrades. Contact the Software Update Service at 1-800-809-2772 or fax 614-899-4141.

Repair and Upgrade Service **614-882-3282 ext. 7601**
FAX 614-882-3414

Our well-equipped Customer Service department is ready to assist you with repairs, upgrades, and spare parts services. If a situation arises where one of these services is needed, just call 614-882-3282 x7601 or fax 614-882-3414.

Product Ordering Service **614-882-3282**
FAX 614-882-6532

Authorized Cutler-Hammer distributors may place product orders directly with our Order Processing department by calling 614-882-3282 x406 or faxing 614-882-6532. For information on your local distributor, call the Cutler-Hammer Tech Line.



Customer Support Center

1-800-356-1243

Authorized Cutler-Hammer distributors and Cutler-Hammer sales offices can get assistance for Cutler-Hammer standard and component product lines through the Customer Support Center. Call the Customer Support Center for the following assistance:

1. Stock availability, proof of shipment, or to place an order.
2. Expedite an existing order.
3. Product assistance and product price information.
4. Product returns other than warranty returns.

For information on your local distributor or sales office, call the Cutler-Hammer Tech Line at 1-800-809-2772.

Correspondence Address

**Cutler-Hammer
P.O. Box 6166
Westerville, OH 43086-6166**

Shipping Address

**Cutler-Hammer
173 Heatherdown Drive
Westerville, OH 43081**



PanelMate Power Series/PC Features

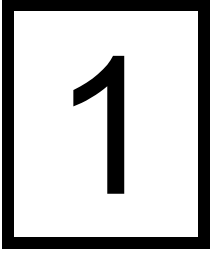

In this chapter, you will learn:

- *PanelMate Power Series and PanelMate PC online features*
- *Chapters you can skip in this manual*



PanelMate Power Series/PC Features

Online features for the PanelMate Power Series operator stations and PanelMate PC are listed below.

- alarm reporting and acknowledgment
- templates:
 - indicator
 - readout
 - bar
 - table
 - bar trend
 - line trend (optional)
 - display
 - maintenance (optional)
 - variable-sized indicator
 - variable-sized bar
 - variable-sized readout
 - variable-sized display
 - variable-sized graphic
 - variable-sized control button
- Windows-based configuration environment

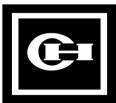
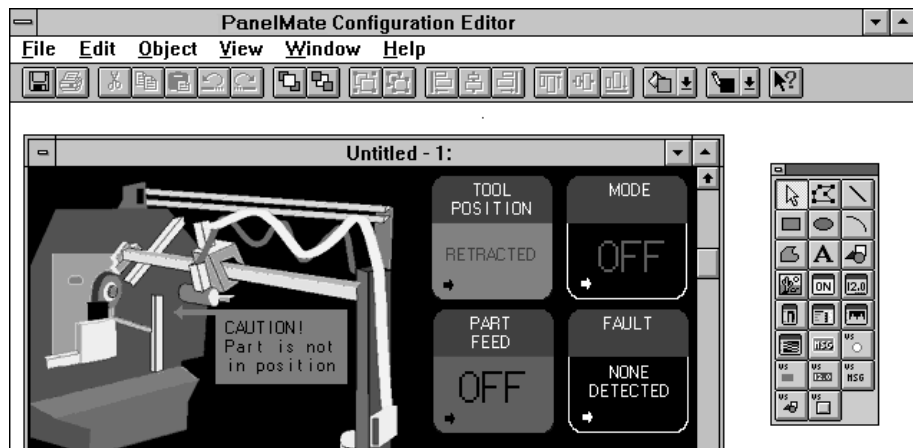

- pixel-based PowerGraphics™ capabilities, including:
 - object-oriented graphics
 - 256 color support
 - exclusive PowerAnimation and PowerBlink capabilities
 - ability to import graphics from 3rd-party packages
- Touchscreen and keypad models with display sizes from 8-inches to 14-inches
- PanelMate PC, which allows configurations to run on an industrial personal computer with the PanelMate PC Runtime Software.



Using the Rest of this Manual

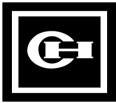
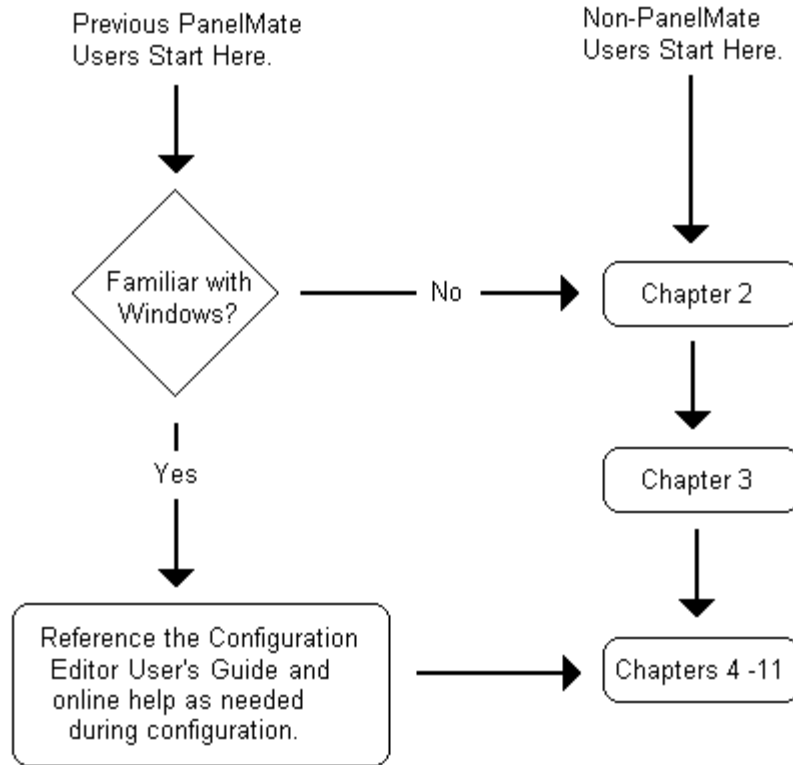

How PanelMate Operator Stations Work Online



In this chapter, you will learn:

- *What role a PanelMate operator station plays in factory automation*
- *How a PanelMate operator station partners with a PLC*
- *How operators interact with a PanelMate operator station*
- *How a PanelMate operator station uses standardized on-screen tools called “templates”*
- *About the advanced graphics tools*
- *About the alarm annunciation capability*
- *What additional features are available*
- *How multiple screens or “pages” can be organized for best operator use*



What Role a PanelMate Operator Station Plays in Factory Automation

Conventional operator stations consist of individual devices (pushbuttons, lamps, etc.) hard-wired to I/O points.

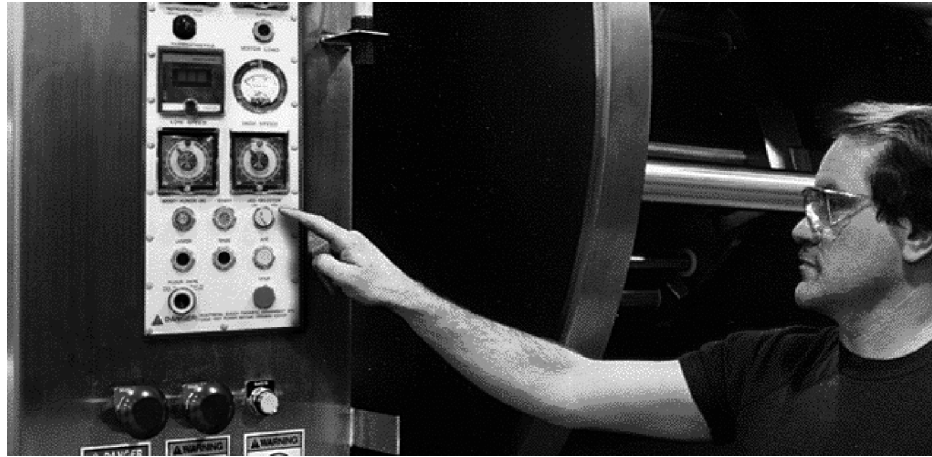

The PanelMate operator station replaces conventional operator stations and associated hard-wired devices:



Conventional hard-wired operator stations connect to PLCs symbolically as shown in this diagram:

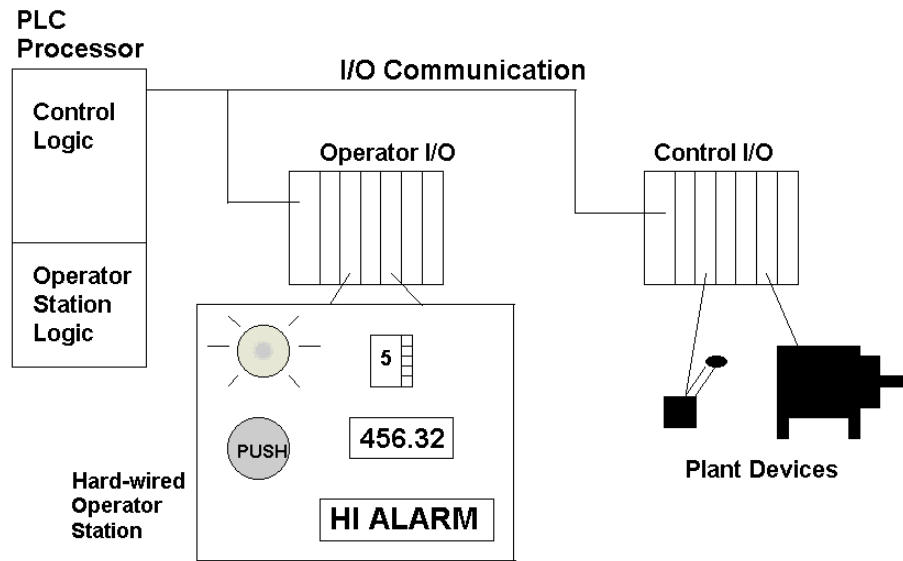

On the operator station shown above:

- pushbuttons and thumbwheels are input devices which require PLC input modules
- lamps, numeric readouts and message displays are output devices which require PLC output modules
- specific PLC ladder logic is required to support the inputs and outputs of the operator station



PanelMate operator stations connect to PLCs/controllers symbolically as shown in this diagram:

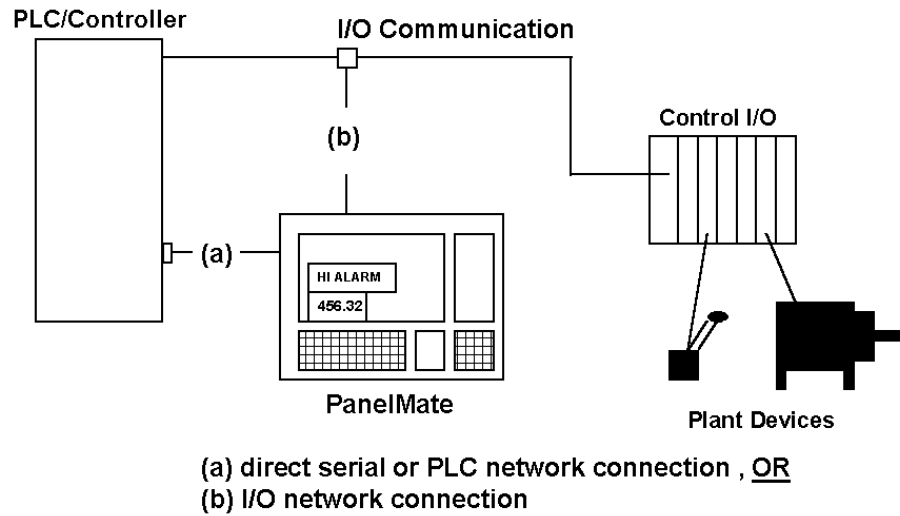

The PanelMate operator station performs all the same control and monitoring functions as the devices on a hard-wired operator station, plus adds many more capabilities.

It also:

- eliminates the need for PLC I/O modules to support the operator interface
- eliminates most PLC/controller ladder logic needed for operator interface support
- often occupies less space than conventional operator stations
- provides greater flexibility to customize the appearance and content of displays, and to expand and make changes at a later date



How the PanelMate Operator Station Partners with a PLC

PanelMate operator stations can:

- communicate to hundreds of varieties of PLCs/controllers.
- communicate directly to one PLC or to multiple PLCs and PLC and controller networks
- communicate with multiple networked PLC simultaneously from the same “page” (screen)

PanelMate operator stations physically connect to PLCs or their networks via cabling directly to a PLC port, network connection node or interface module (depending on the PLC brand).

- PanelMate Power Series 1500, 2000, 3000, 4000, and 5000 can support 2 serial ports plus a PLC network interface card
- PanelMate PC can support up to 4 serial port connections or 2 serial ports plus a PLC network interface card. The PanelMate PC can simultaneously support a connection to a NetSolver application (running on the same personal computer), a connection to a PLC network interface card, as well as connections to multiple DDE or OPC Servers.

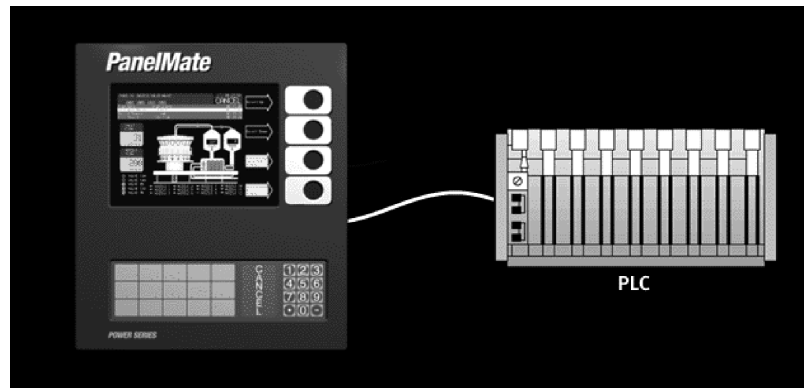

This means that:

- The PanelMate operator station supports connections to two PLCs or controllers simultaneously
- The PanelMate PC supports connections to four communication interfaces simultaneously
- The PanelMate operator station does not directly connect to the I/O points



Except when it is operating on a PLC's remote I/O network, the PanelMate operator station is usually the "master" device when it communicates to the PLC. This means that:

- the PanelMate operator station polls the PLC or network to write or to read information
- the PLC does not need extra rungs of ladder logic to *send* information to the PanelMate operator station

PanelMate operator stations feature extensive built-in capabilities to perform mathematical calculations, alarm annunciation, image animation, and more. This means that:

- the PanelMate operator station eliminates the extensive additional PLC/controller ladder logic which might otherwise be needed to support operator interface activities

When the PanelMate operator station is connected to a remote I/O network such as S908, it communicates differently than with all other serial or network connections. When the PanelMate operator station is on the remote I/O network, it appears to the PLC as if it were a PLC I/O rack. This means:

- the PLC is now the master - it determines when to update information to the PanelMate operator station or when to receive inputs from the PanelMate operator station
- the PLC/controller requires ladder logic to specifically send updates to PanelMate operator station and to receive inputs (such as operator entries) from the PanelMate operator station. This "block transfer" logic is a standard requirement of such remote I/O networks.

When the PanelMate PC is communicating to a DDE Server as a DDE Client, then the DDE Server sends data to PanelMate operator station as it changes. Therefore, PanelMate does not poll the DDE Server data. Instead of polling the DDE Server data, the PanelMate operator station establishes and de-establishes DDE requests to the DDE Server as required by the specific application.

Refer to the appropriate Communications Driver Manual for more specific information about PanelMate communicating to a PLC or controller.



How Operators Interact with the PanelMate Operator Station

Operators interact with the PanelMate operator station in two basic modes:

- they monitor events through the PanelMate operator station
- they take action through the PanelMate operator station

Monitoring is supported with the following PanelMate capabilities:

- on-screen representation of status, annunciation of alarm information, and presentation of instructions
- audio annunciation of events through the connection of an optional audio horn
- logging of events through the use of an optionally-connected serial printer



Taking action is supported by permitting operators to press the equivalent of momentary-contact or maintained (latched) control buttons and to perform numeric entry.

- keypad-based online units feature either 4 or 5 control buttons whose functions are configurable. Note that a separate keypad exists for numeric entry.

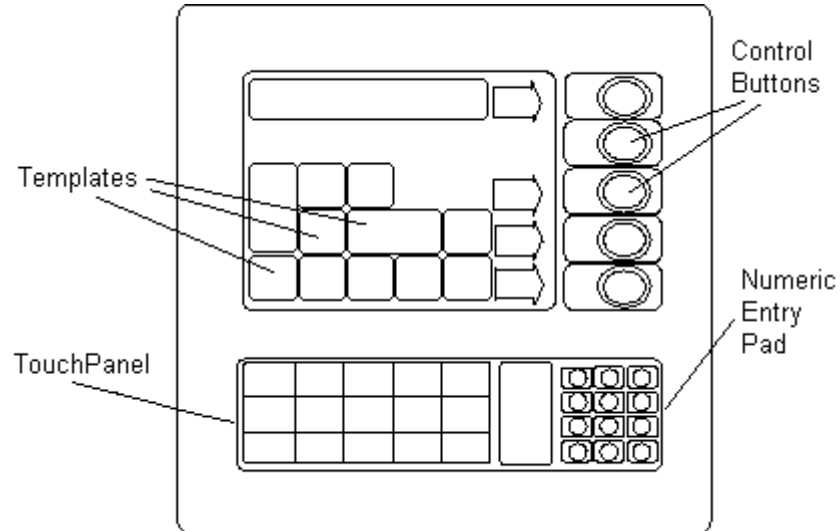

- touchscreen-based online units provide configurable on-screen control button touch areas and a pop-up numeric entry keypad. All PanelMate touchscreen units offer a choice of 2 different pop-up numeric entry keypads (i.e., a two-column or three-column keypad).
- industrial computer-based units (used with PanelMate PC configurations) allow operators to use the industrial computer's pointing device (touchscreen, mouse, etc) to activate on-screen control buttons and access a pop-up numeric entry keypad (i.e., a two-column or three-column keypad).



Standardized On-screen Tools Called “Templates”

The most basic job of a PanelMate operator station is to replace the functions of traditional hard-wired operator station devices such as pushbuttons, lamps and message displays.

To replace each category of hard-wired device, the PanelMate operator station supplies a specific visual tool or “template” which can be arranged onscreen with other templates. The standard template types and the devices that they replace are:

<u>Template type</u>	<u>Conventional Devices Replaced</u>
indicator	lamps, legend plates, pushbuttons
readout	numeric displays, thumbwheels
bar	gauge, dial or faceplate
display	message display
table	readout and thumbwheel batch array
maintenance	timer/counter access module
trend	chart recorder
advanced trend	

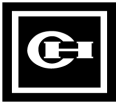
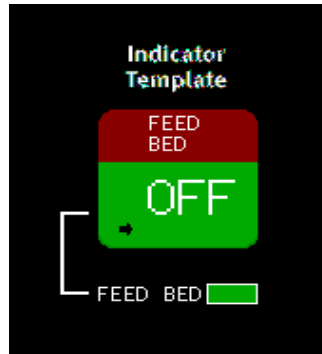

Steps to installing a template on a screen are:

- using the Windows-based configuration software, select the desired template from the selection toolbox, then drag & drop onto the screen
- fill out the tabbed dialog boxes to define text, color and other attributes
- enter the PLC/controller address information to link visual appearance of the template to events represented in the PLC/controller
- specify the addition of operator control buttons or numeric entry to be associated with the template

During online or runtime operation, the operator may:

- observe a particular template
- touch or select a template to “arm” control buttons or numeric entry, if desired
 - To select a template on a touchscreen unit, touch the template.
 - To select a template on a keypad unit, use the touchpanel to select the corresponding template.
 - To select a template on a PanelMate PC, use a pointing device (touchscreen, mouse, etc.) to select a template.
- press any desired control buttons or numeric key selections to take action

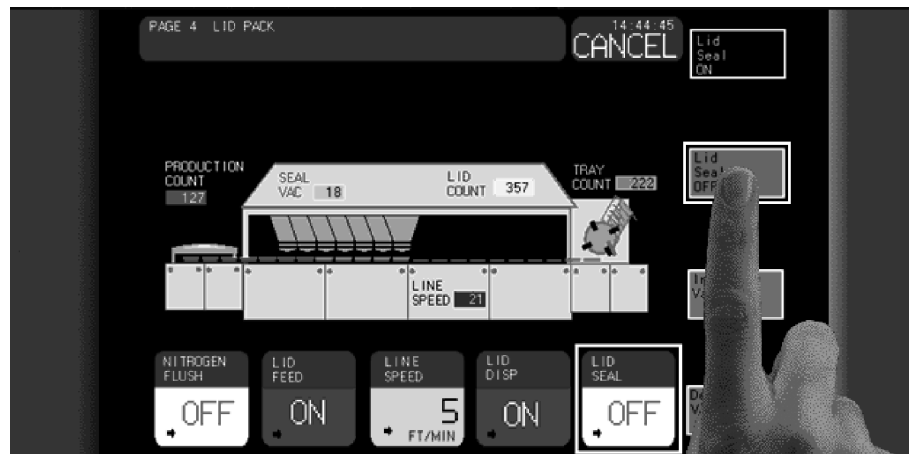

Advanced Graphics Tools

In addition to templates, the PanelMate operator station provides the ability to construct custom graphics images for inclusion on any page.



Graphics are typically used to provide visual detail about an application that templates cannot. Graphics can be intermixed with templates on any page, and can:

- be created and stored in a library for later recall and use
- be used for static appearance enhancement
- be linked to events in the PLC/controller to produce a dynamic appearance
- be used to show motion, with the PowerAnimation feature
- be used to get attention, with the PowerBlink feature
- have control button or numeric entry capability “attached” to their appearance



During online or runtime operation, the operator may:

- observes a particular graphic
- touch or select a graphic to “arm” control buttons or numeric entry, if desired
 - To select a graphic on a touchscreen unit, touch the graphic.
 - To select a graphic on a keypad unit, use the touchpanel to select the corresponding graphic.
 - To select a graphic on a PanelMate PC, use a pointing device (touchscreen, mouse, etc.) to select a graphic.
- press any desired control buttons or numeric key selections to take action



Alarm Annunciation Capability

All templates and (dynamic) graphics can be made to generate an alarm based on detection of some event. The detection is set up within the configuration of the tabbed dialog boxes for each template or graphic.

When an alarm situation is detected, the PanelMate operator station responds by:

- generating a separate, blinking alarm message in the reserved alarm area at the top of the screen
- generating a blinking page number at the top of the screen, to advise the operator of the page number on which the alarm is occurring



- generating a copy of the alarm message to any printer attached to the PanelMate operator station if desired
- logging the alarm on the separately-displayable alarm page, which can list up to the 100 most recent alarms
- generating an alarm tone (if desired) to an optionally connected alarm horn (PanelMate PC and PanelMate Power Series 1500 do not provide an external alarm horn.)

When the alarm situation is resolved or cleared, the PanelMate operator station:

- removes the blinking page number from the top of the screen
- removes the alarm message from the top of the screen
- lists as "cleared" the alarm reported on the alarm page
- prints a specific "alarm cleared" message to any printer connected to the online unit



Additional Features Available

The PanelMate operator station has many additional features available to provide convenience and flexibility in partnering with PLC/controllers. These features are accessible from the System Parameters Table (see the **System Parameters** topic in the PanelMate Power Series/PC Configuration Editor User's Guide). A few of the often-used capabilities include:

- specifying the page which the PanelMate operator station should display at powerup
- setting various parameters related to password protection of operator entries
- resetting the internal clock which is used to time-stamp alarms
- specifying the volume of the optional audio feedback for key presses and alarms
- setting a time following a key press after which the screen will go blank to reduce CRT monitor aging



Organizing Multiple Pages for Best Operator Use

Some PanelMate applications may require fewer than 5 pages, while others may require many. In either case, here are some organizational guidelines:

- organize pages to meet the needs and responsibilities of the people who will use the online unit (it may be more than one category: e.g., online operator plus maintenance technician)
- make it easy to locate pages which will be used often
- group together numbered pages which have common functionality
- “layer” multiple pages from the most general view of operations to more focused views

One example of a multiple-page organization:

Page Number(s)	Content
00	Department Overview Mimic Diagram
01	Machine #1 Mimic and Manual Controls
02	Machine #2 Mimic and Manual Controls
03	Machine #3 Mimic and Manual Controls
06	Production Data Trends
07	Machine Uptime/Downtime Summary
08	Machine Diagnostics
11 *	Repair Instructions - Machine #1
12 *	Repair Instructions - Machine #2
13 *	Repair Instructions - Machine #3

* password-protected for access by technicians only



From Opening the Boxes to Running Online: A Master Startup Flowchart



In this chapter, you will learn:

- *The overall sequence of steps necessary to configure, load, and run a PanelMate operator station*
- *What chapters in this manual provide specific startup guidance*



The Master Startup Flowchart

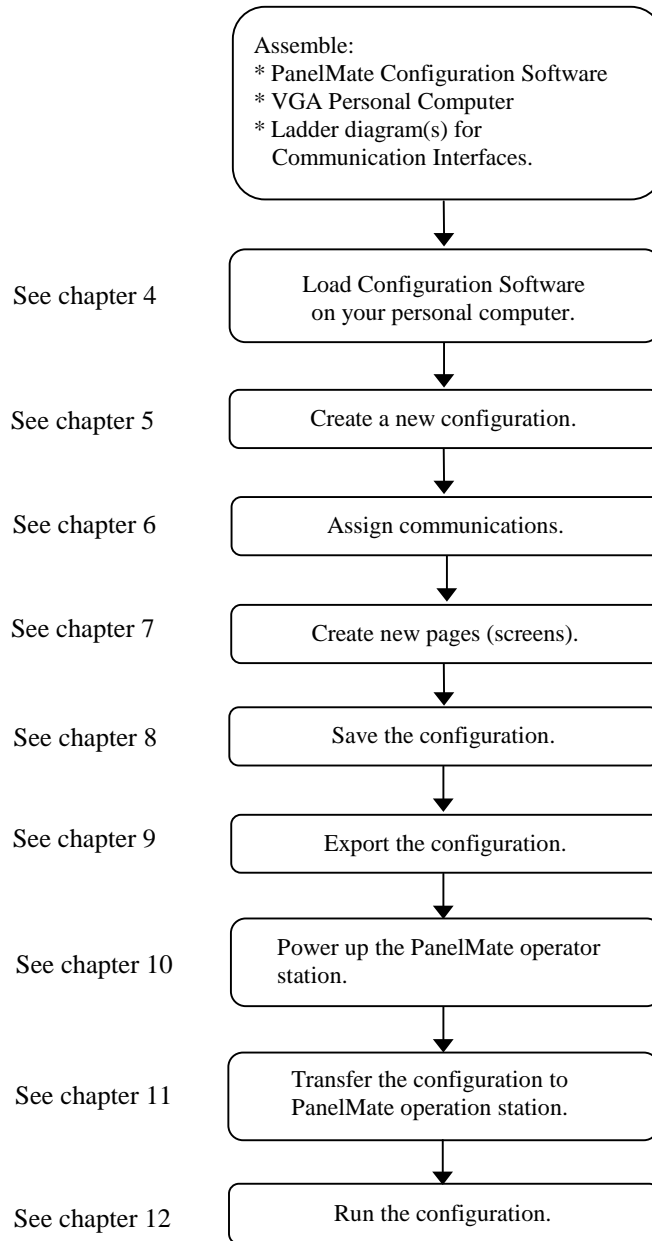

Installing the Configuration Software

4

In this chapter, you will learn:

- *About the system requirements*
- *How to use the Setup Program to install the software*



System Requirements

The following table shows the software and hardware requirements for installing and running the PanelMate Configuration Software.

Operating System	Microsoft Windows NT Microsoft Windows 95 Microsoft Windows version 3.1 or later Microsoft Windows for Workgroups version 3.X
Microprocessor	486/66MHz or higher for Microsoft Windows version 3.X Pentium or higher for Microsoft Windows 95 Pentium 133MHz or higher for Microsoft Windows NT
Memory	8 MB or higher for Microsoft Windows version 3.X 16 MB or higher for Microsoft Windows 95 32 MB or higher Microsoft Windows NT
Hard disk space	9 MB Typical
Disk drive	CD-ROM drive, or use the "Make Disk" utility for a 3.5-inch drive installation
Video adapter	VGA or higher resolution; recommended environment is 640X480 with 256 colors (software will operate with fewer colors but some advanced PanelMate features may not be viewable)
Display device	Color or gray scale monitor or other display device (LCD, gas plasma, etc.); Monochrome displays are not recommended since blink attributes cannot be viewed.
Pointing device	Microsoft Mouse or compatible pointing device



The following table shows the software and hardware requirements for installing and running the PanelMate PC Runtime Software.

Operating System	Microsoft Windows NT 4.0
Microprocessor	Pentium 133MHz or higher
Memory	32 MB (64 MB if running with NetSolver)
Hard disk space	4 MB
Disk drive	CD-ROM drive, or use the “Make Disk” utility for a 3.5-inch drive installation
Video adapter	VGA or higher resolution; required Color Palette setting is 256 colors
Display device	Color CRT or Flatpanel Display Device
Pointing device	Touchscreen, Mouse, or compatible pointing device



Running the Setup Program to Install the Software

Note that before installing the configuration software, make sure that you close all open applications.

The Software Kit contains either a CD-ROM or floppy disks. For CD-ROM installation instructions, refer to the Install.txt file on the CD-ROM. For floppy disk installation instructions, refer to the paragraphs that follow.

The Configuration Software contains an installation program named Setup. Setup is on the diskette labeled "Configuration Software Disk 1".

To install the Configuration Software on your hard disk, insert the diskette in your personal computer. If you are using Microsoft Windows, open the File Menu and select Run in the Program Manager. If you are using Microsoft Windows 95 or Microsoft Windows NT, press the **Start** button and select Run.

In the **Run** dialog box, type:

```
drive: \SETUP
```

in the Command Line entry field, where *drive* is the letter of the floppy drive that contains the diskette. Choose the **OK** button.

When the **Welcome** dialog box appears, read the message and press the **Continue** button. In the next dialog box, register the software by entering your name and your company name and press the **Continue** button.

In the **Installation Options** dialog box, you can change the installation directory and perform a full or custom installation. If you wish to change the installation directory, press the **Change Directory** button. If you wish to customize the installation, you may de-select any of the subcomponents you do not wish to install.

Subcomponent files which can be selected or de-selected for a custom installation are:

- Configuration Software files
- Configuration Database files
- Transfer Utility files
- Executive Firmware files
- PanelMate PC Runtime files

Tip: A custom installation will reduce both the amount of disk space consumed and the time required for installation.



Note the following items:

- If upgrading or installing the software in the same directory as a previous PanelMate software version, you do not need to install the Configuration Database files. (When you open the Configuration Software, you will be prompted to upgrade the database for the installed software version.)
- The PanelMate PC Runtime files should only be installed on a personal computer with Windows NT.
- If installing the PanelMate Runtime Software only, de-select the other selections and only check the box for the PanelMate PC Runtime selection, or you may install the Runtime Software from your diskette or CD-ROM.

After selecting the directory and subcomponent files to install, press the **Install** button. When the installation is finished, press the **Yes** button in the **Question** dialog box to view the readme.txt file. The readme.txt file will list all the issues addressed from the previous version of software, list the enhancements to the current version of software, and list new issues with the current version of software. After viewing the readme.txt file, press the **OK** button in the **Installation Complete** dialog box.

Tip: Cutler-Hammer recommends that you reboot your system after the software installation is completed.



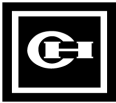

Creating a New Configuration



In this chapter, you will learn:

- *About the PanelMate Configuration Editor Main Screen*
- *How to start a new Configuration*



The Configuration Editor Main Screen

The Setup program creates a group named “PMCONFIG” with the PanelMate Configuration Software icon. Double click on the icon to launch the program bringing you to the Main Screen.

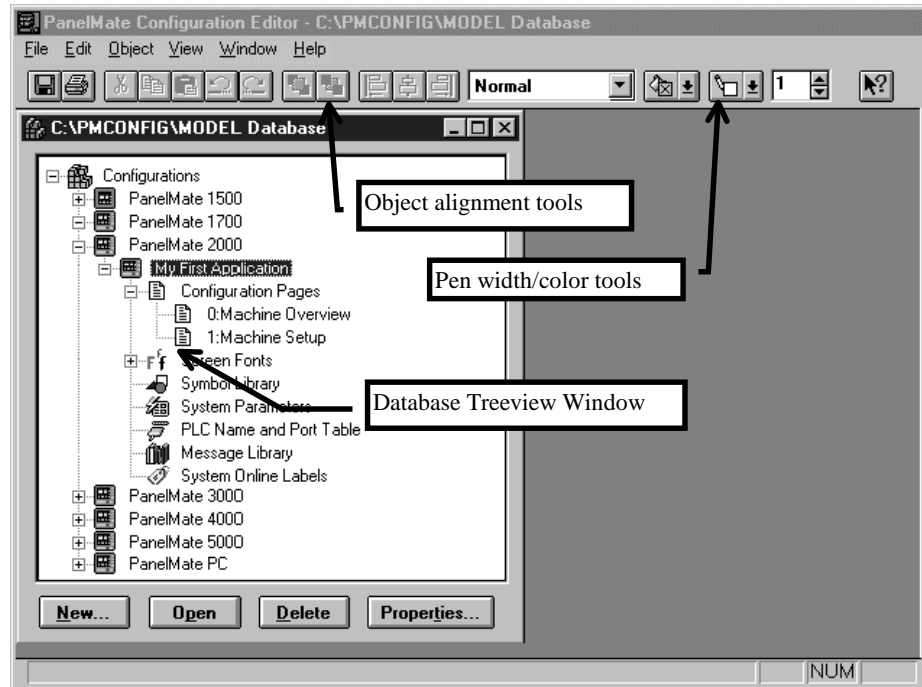

Tips:

- The standard Windows tool buttons for File Save, Print, Cut, Copy, Paste, Undo, and Re-do operate as they would in most Windows-based drawing packages.
- Special PanelMate Configuration Editor tool buttons for aligning and ordering objects in displays, fill and pen color, and width operate as they would in most Windows-based drawing packages.
- Context-sensitive Help is available for most operations using the **Help**  button.



Starting a New Configuration

Select the **New** button on the Database Treeview Window to indicate that you wish to create a new configuration (set of displays for an online unit). This will bring up the **New Configuration** dialog box used to specify basic information about your new configuration.

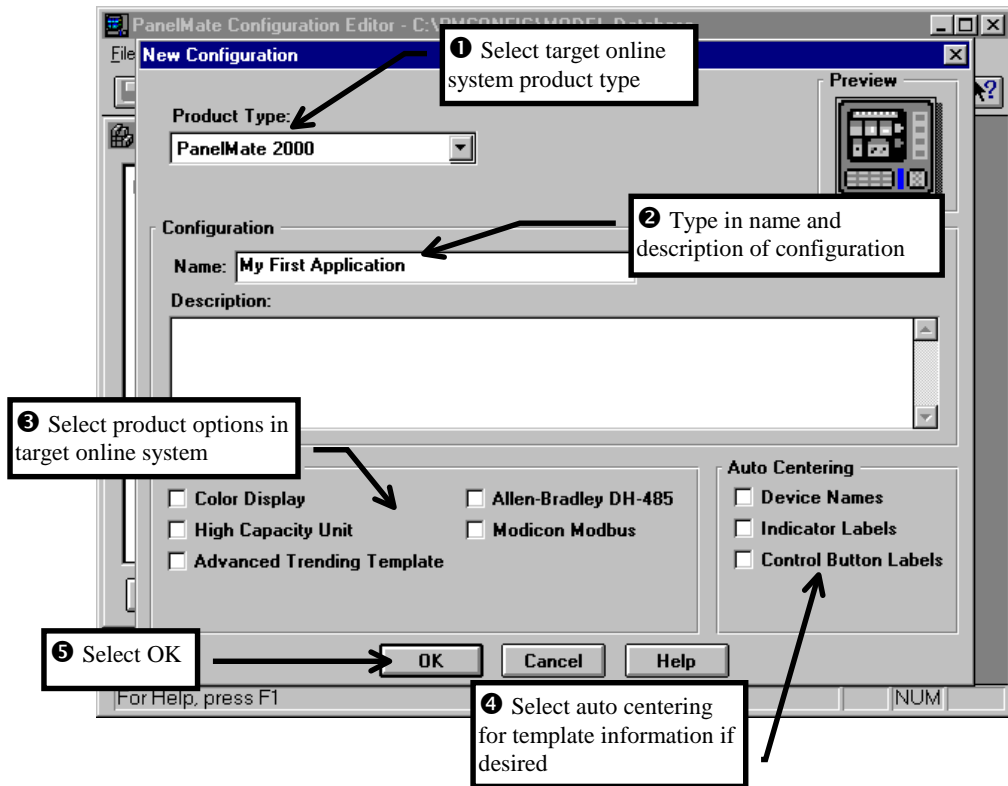

Tips:

- Be sure to select the Color Display option if target online system is color. Note that PanelMate Power Series 4000, PanelMate Power Series 5000, and PanelMate PC automatically select the Color Display option.
- The **Tab** key or mouse can be used to move to new fields in the dialog box.
- The **Enter** key will “complete” the dialog box and close the dialog box (except when entering a multi-line description).
- The Configuration Name may be up to 32 characters and will be used for identification of this configuration in the Database Treeview Window. Note that the Description field is for reference only.
- Options can be changed by clicking the **Properties** button on the Database Treeview Window (except for the Product Type). If the Product Type is incorrect, press the **Delete** button on the Database Treeview Window and start configuring the **New Configuration** dialog box over again.



Assigning Communications

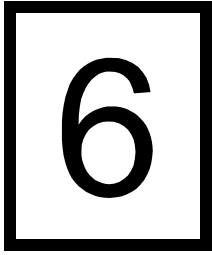

In this chapter, you will learn:

- *Where to find the necessary communications setup information*
- *How to configure the PLC Name and Port Table*



Determining Communication Information

This chapter explains how to setup communications. Additional PLC/controllers can be added after successfully establishing communications.

Depending on the PLC or controller driver to be used, all or some of the following information will be needed:

- Communications Driver
- PanelMate ID (Local ID)
- Electrical Setting
- Baud Rate
- Data Bits
- Stop Bits
- Parity
- PLC/Controller Processor Model
- PLC/Controller Processor Node ID (Remote ID)

Contact the Cutler-Hammer Customer Support Department at 1-800-809-2772 if assistance is needed in collecting this information.



Configuring the PLC Name and Port Table

When a Configuration Name is opened in the Database Treeview Window, the PLC Name and Port Table selection will appear.

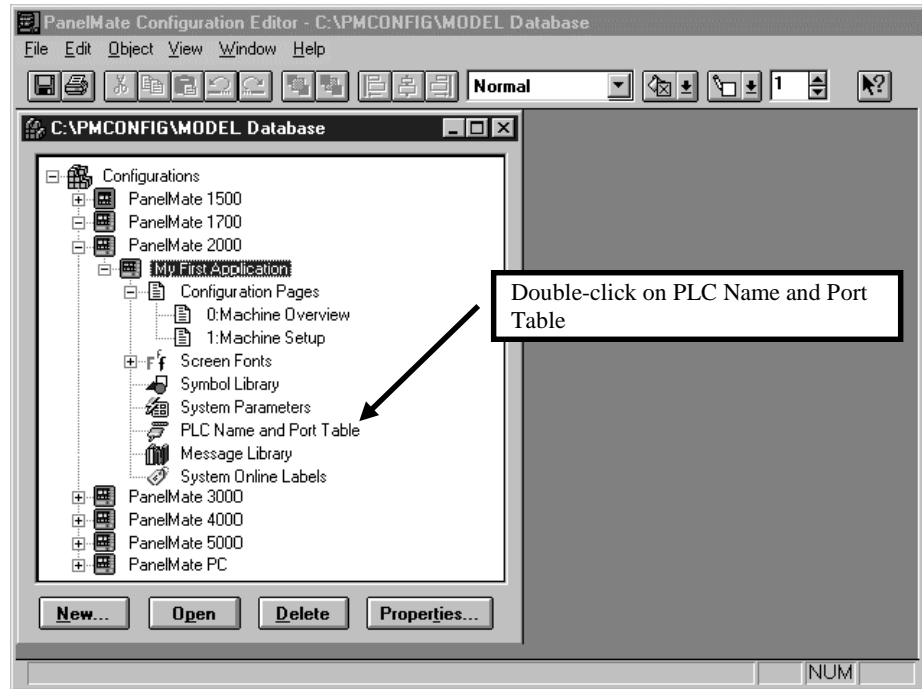

Configure Port Parameters Information

Setup the Port Parameters as follows:

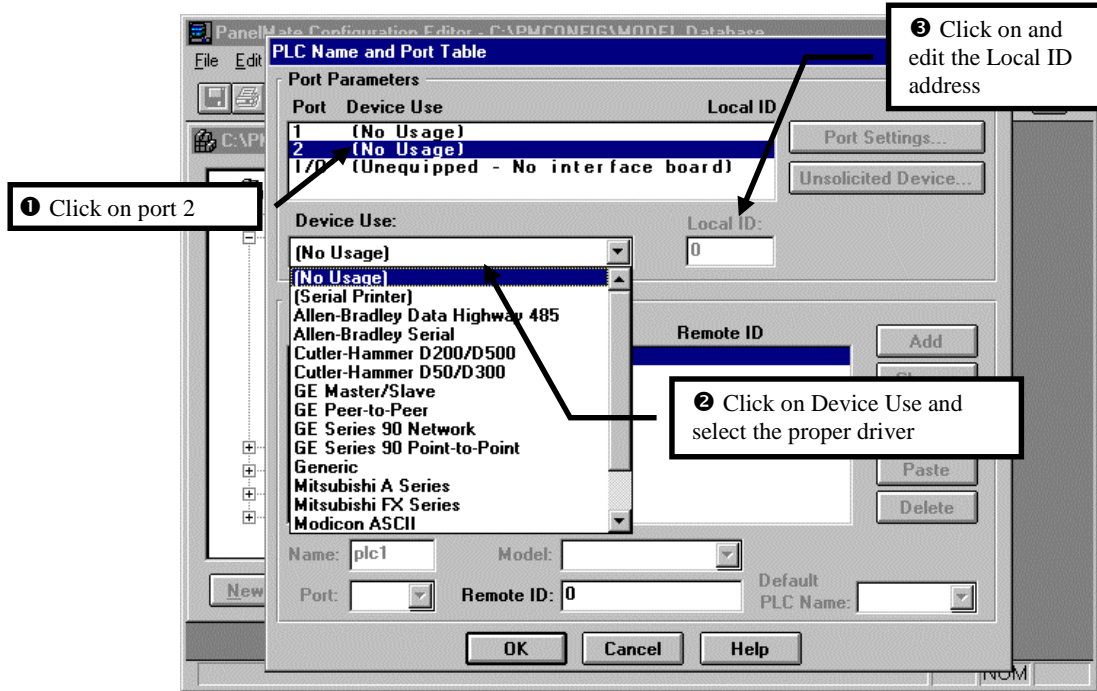

Tips:

- Port 1 can be used, but is normally left unconfigured. Port 1 can be used for future downloading from a personal computer without disconnecting from the PLC/controller.

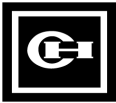

Continue configuring the PanelMate communication port as follows:

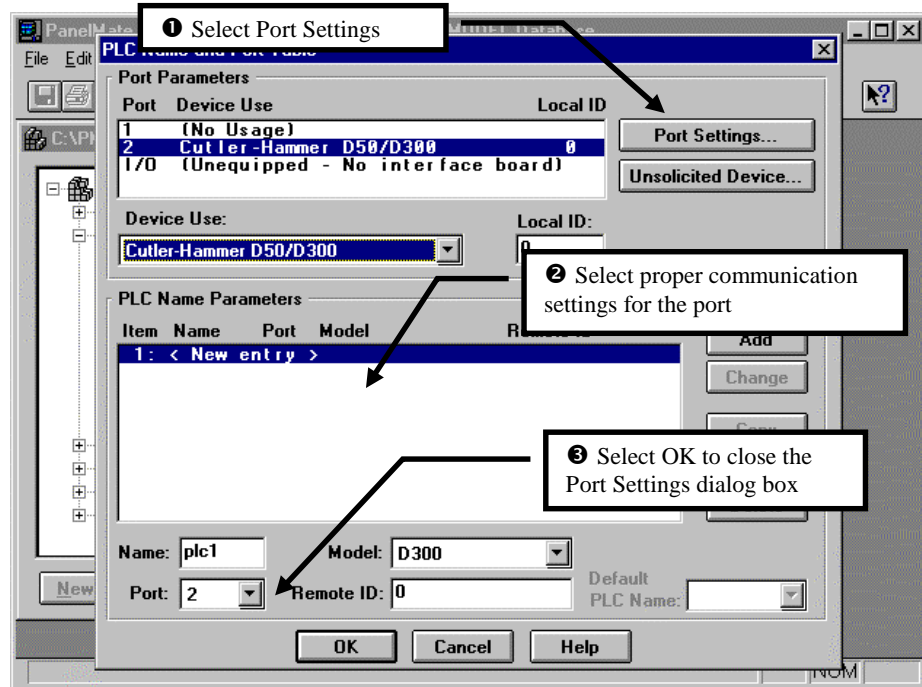

Configuring the PLC/Controller Processor

The PLC/Controller Processor or Communication Module must be configured to match the values entered in the PanelMate Configuration Software.

Reference the Communications Driver Manual for specific PLC/controller setup instructions. The following parameters are normally configured in the PLC or controller using programming software or dip switches:

- Electrical Setting
- Baud Rate
- Data Bits
- Stop Bits
- Parity
- PLC/Controller Processor Node ID (Remote ID)
- Protocol (PanelMate driver type)

These parameters **must** match the values used in the PanelMate Configuration Software.

Contact the Cutler-Hammer Customer Support Department at 1-800-809-2772 if assistance is needed with determining this information.



Configure PLC Name Parameter Information

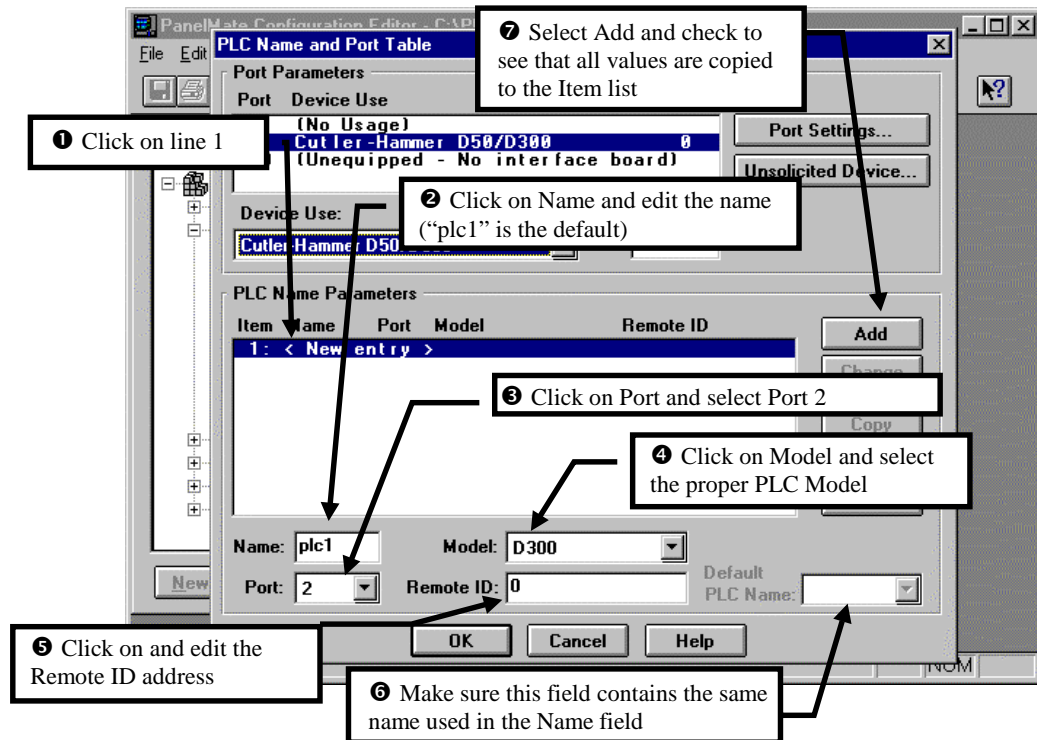

Tips:

- If the exact PLC or controller model is not listed, select a model that has the same or similar address ranges.
- The PLC Node ID settings must match the Remote ID. Do not use leading zeros when entering the Remote ID.
- When creating a PanelMate PC configuration, the DDE or OPC Server and NetSolver communication interfaces will also display in the Device Use field in the PLC Name and Port Table.



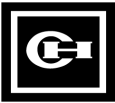

Creating New Pages



In this chapter, you will learn:

- *How to use the Database Treeview Window*
- *How to open a new page*
- *How to add and configure templates*
- *How to edit and use the Message Library*



Using the Database Treeview Window

Applications are created, deleted, opened, and their components accessed using the Database Treeview Window. The Database Treeview Window looks and acts much like the Microsoft Windows File Manager with applications automatically listed under their corresponding model series. Likewise, the components making up an application are automatically listed under the associated application.

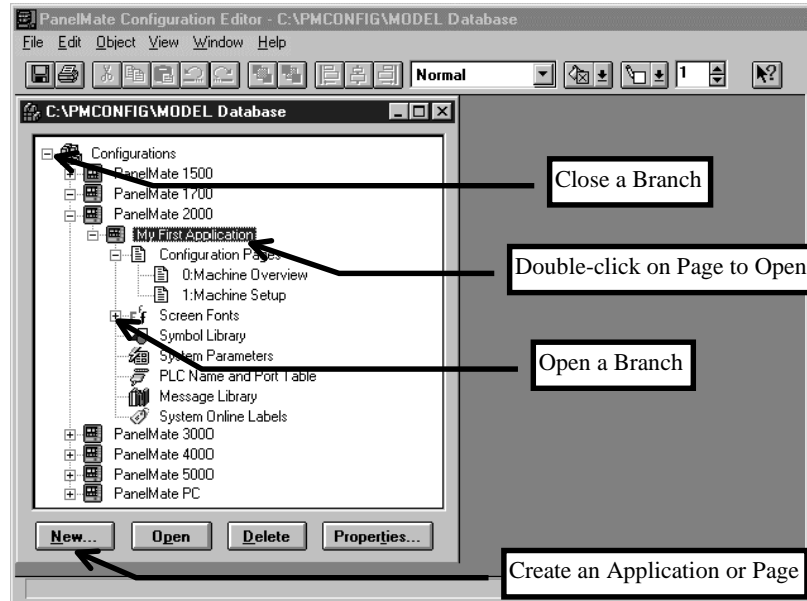

Tips:

- To open and close branches of the tree, click on the “+” and “-” icons or double-click the branch.
- To create a new application, select the appropriate PanelMate model in the Database Treeview Window and press the **New** button.
- To create a new page, choose the Configuration Pages selection for the application and press the **New** button.
- To open a page or application component for editing, select it and press the **Open** button or double-click on it.
- Pages and application components can be copied and moved by selecting them and using the standard Windows “Edit” commands. Note that individual symbols and entire Symbol Libraries may also be copied in this manner.



Creating New Pages (screens)

Overview Flowchart

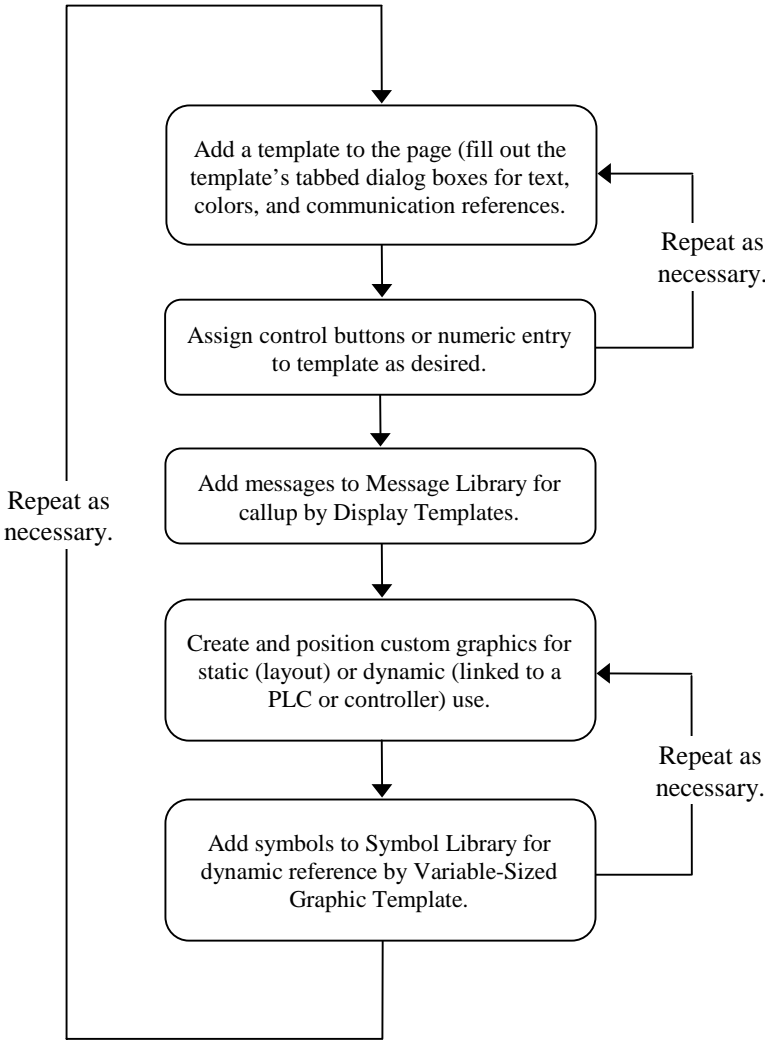

Creating a Page

Add a page to an application as follows:

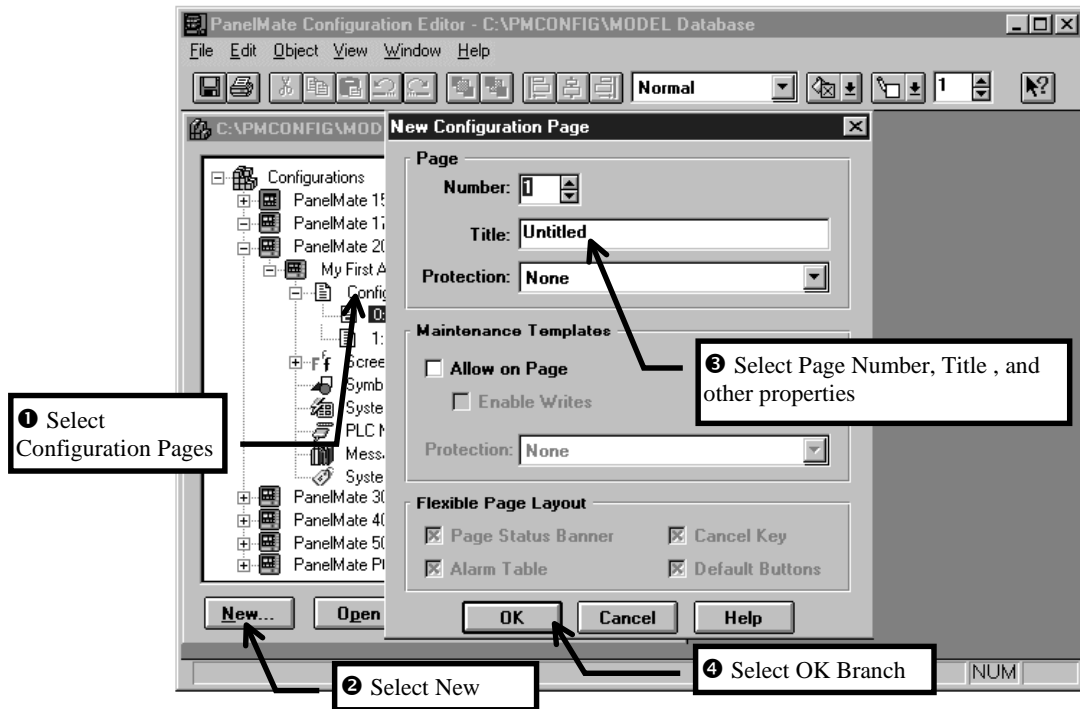

Tips:

- Edit the Protection field to password protect a page from being accessed on-line.
- Maintenance Templates can be used to access any PLC/controller register dynamically on-line and can be made read-only or password protected from register write access.



Opening a Page

Open one or more application pages as follows:

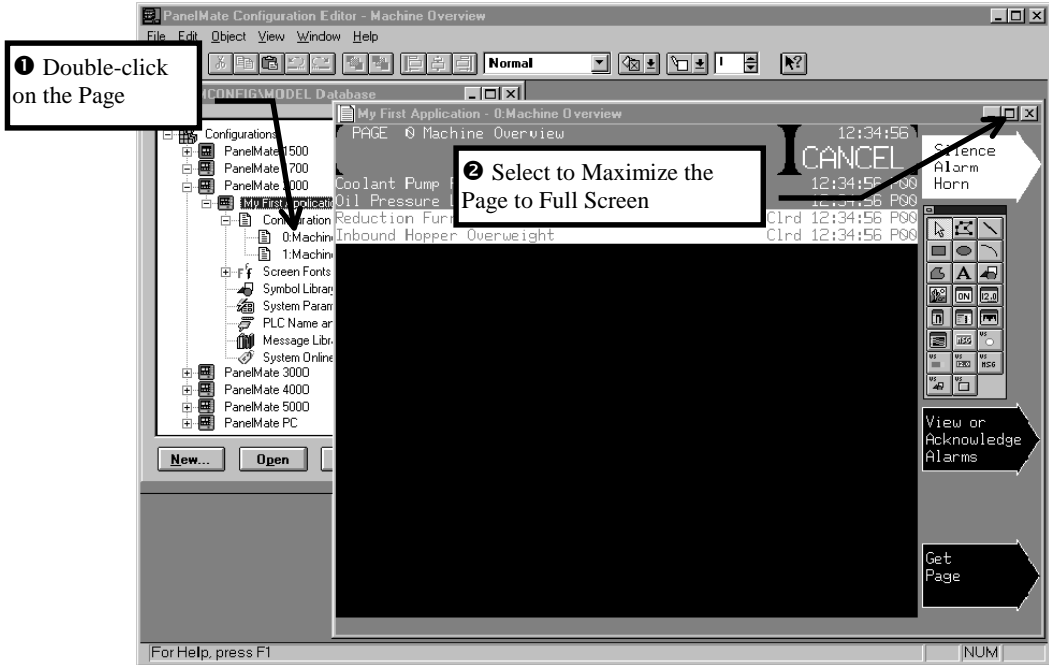

Note that when a new page is opened, an Alarm Window is displayed with sample text. This is provided to help you visualize the online area of the Alarm Window. The text cannot be modified and will not appear in the online configuration.

Tips:

- Pages can also be opened by selecting the page in the Database Treeview Window and selecting the **Open** button.
- Use the Minimize button to minimize the page to an icon when editing multiple pages at once.
- Use the scroll bars at the right edge and bottom of the page to see control button labels and other templates.



How to Configure a Template

Add an Indicator Template to a page as follows:

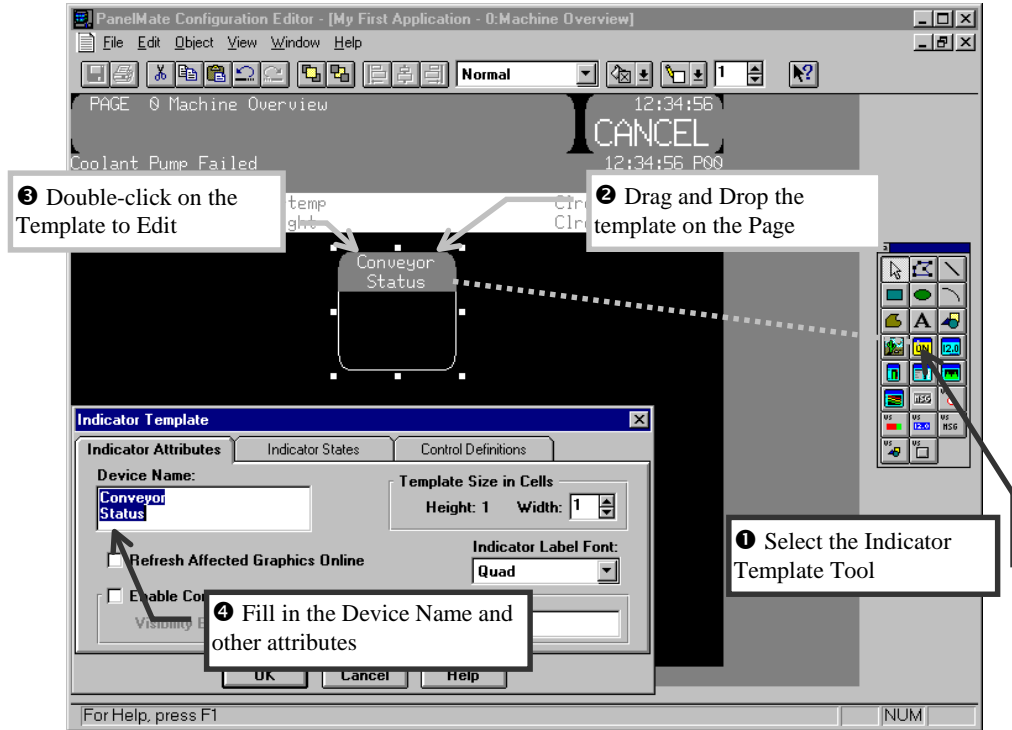

Tips:

- Templates automatically snap to the 3 row by 5 column locations.
- Select Auto Centering attributes when creating an application to allow the Device Name, Indicator Labels, and Control Button Labels text to be centered within the field.
- Use the **Enter** key to add a second line in the device name.
- Other templates are added using the same drag and drop technique.



Edit the states of an Indicator Template as follows:

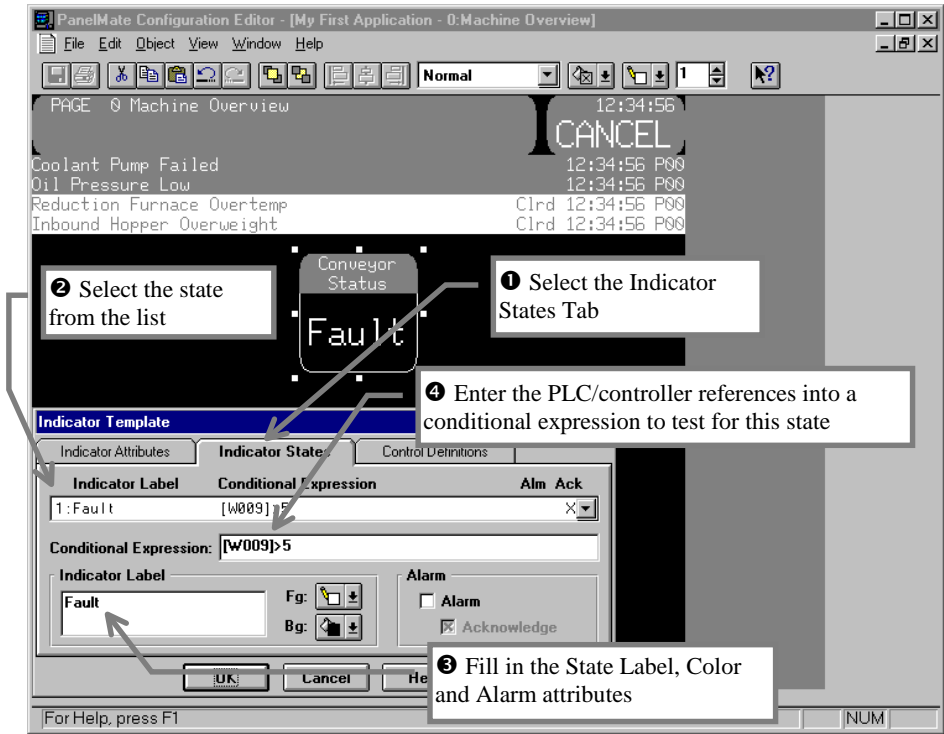

Tips:

- Indicator states are tested from top to bottom in the list for the first true condition.
- Open the pull-down list to see a summary of all states.
- Copy and paste conditional expressions or labels from other states or even other Windows applications by pressing the **Ctrl** and **C** keys simultaneously to copy and pressing the **Ctrl** and **V** keys simultaneously to paste.
- Select the Alarm field to activate an alarm in the PanelMate operator station and the Acknowledge field if the operator should acknowledge the alarm before it is cleared from the screen.



Edit the control button definitions of an Indicator Template as follows:

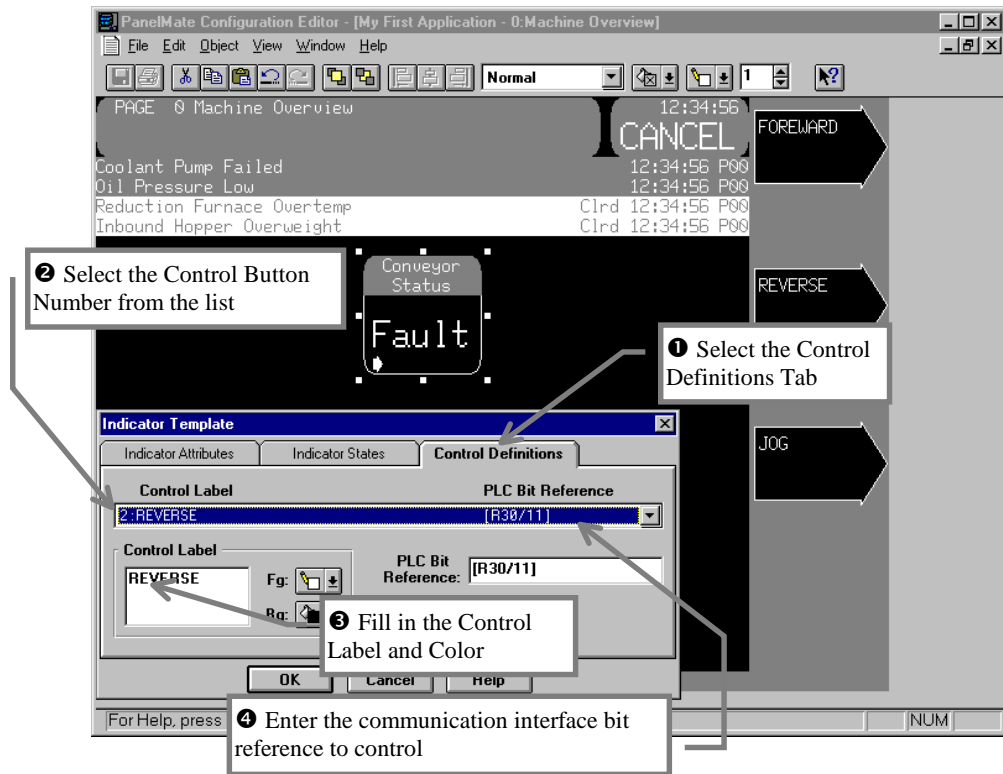

Tips:

- On standard VGA resolution computers (640x480), the top control button label is not visible unless the page area is scrolled up using the right scroll bar.
- PanelMate control buttons act like normally-open momentary pushbuttons.
- PanelMate Power Series models are available with either 4 or 5 control buttons.
- Readout, Bar, and Bar Trend templates offer a choice of button or numeric entry control.
- To move templates and graphics, select them and drag them to their new location, even on another page or another application (source and destination pages should both be opened and not maximized).



How to Configure a Variable-Sized Template

Variable-Sized templates are scaleable versions of the standard PanelMate templates which enable customization of the screen layout.

Add a Variable-Sized Indicator Template to a Page as follows:

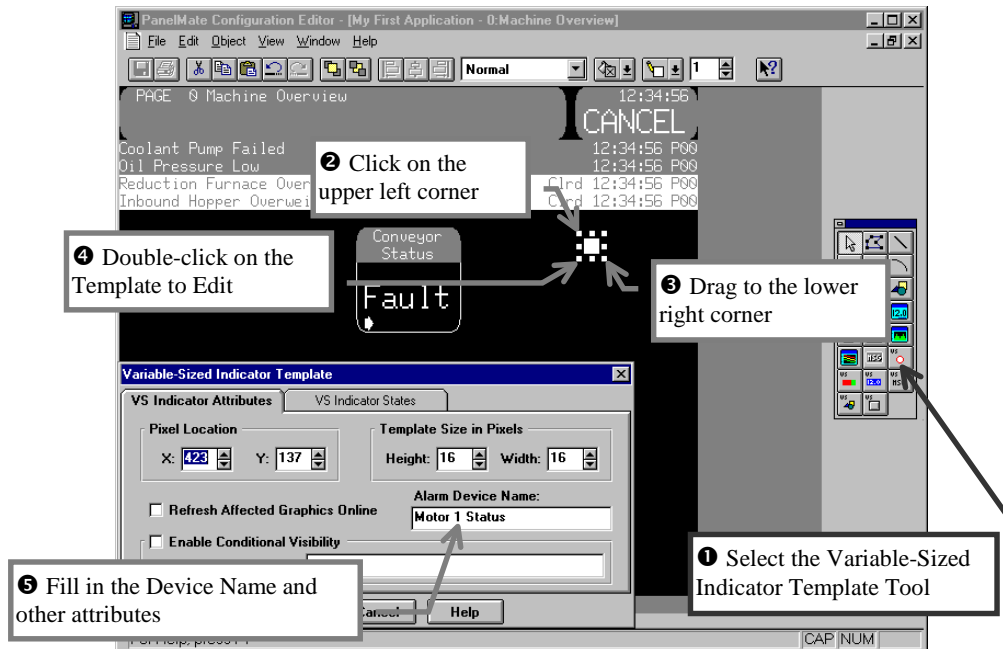

Tips:

- Use Variable-sized templates as labels by placing them on top of graphics.
- Templates and graphics can be resized by using any of the eight white resize handles.
- Variable-Sized templates edit and work the same as larger full size versions.
- To make copies of templates or graphics, select them and hold down the **Ctrl** key while dragging the copy to the new location.
- Select multiple templates and graphics for moving and copying by holding down the **Shift** key while clicking on another item to add to the selection.
- Variable-Sized Control Buttons can be defined as Normally Open – Momentary buttons, Normally Closed – Momentary buttons, Normally Open – Maintained buttons, Normally Closed – Maintained buttons, Toggle buttons, or Page Change buttons. (Note that Normally Open – Momentary is the default setting for Variable-Sized Control Buttons.)



How to Edit and Use the Message Library

The **Message Library** dialog box is referenced by the Display Template and Variable-Sized Display Template. Once accessed from the Database Treeview Window or from the **Message Library** button on the **Display Template – Expressions Tab** dialog box or the **Variable-Sized Display Template – Expressions Tab** dialog box, messages can be edited as follows:

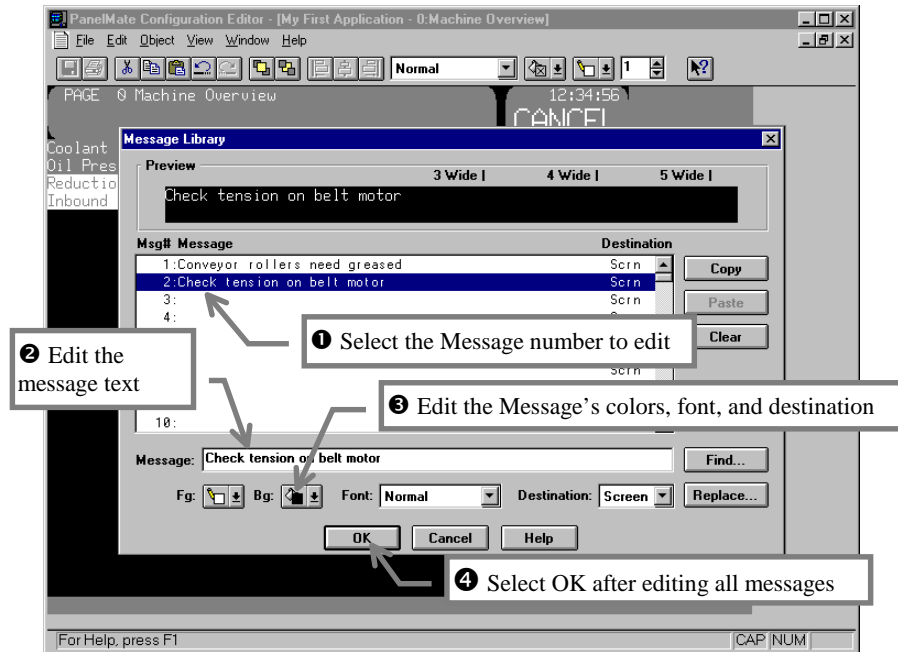

Tips:

- Set the Destination to Printer to create reports and log events to a serial printer attached to the on-line system.
- To select multiple messages, hold down the **Ctrl** key while selecting or hold down the **Shift** key and select the list message to be selected.
- Use the Cut, Copy, and Paste commands to copy messages to other locations in the library or between the Windows clipboard and other applications such as a word processor or spreadsheet program.
- Use Find and Replace to locate or change messages in the Message Library.
- When using Edit or Paste to add messages, be sure to pre-select the correct number of message lines in the Message Table to avoid losing information.

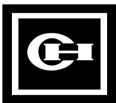

How to Add PowerGraphics to a Page

Add PowerGraphics to a page as follows:

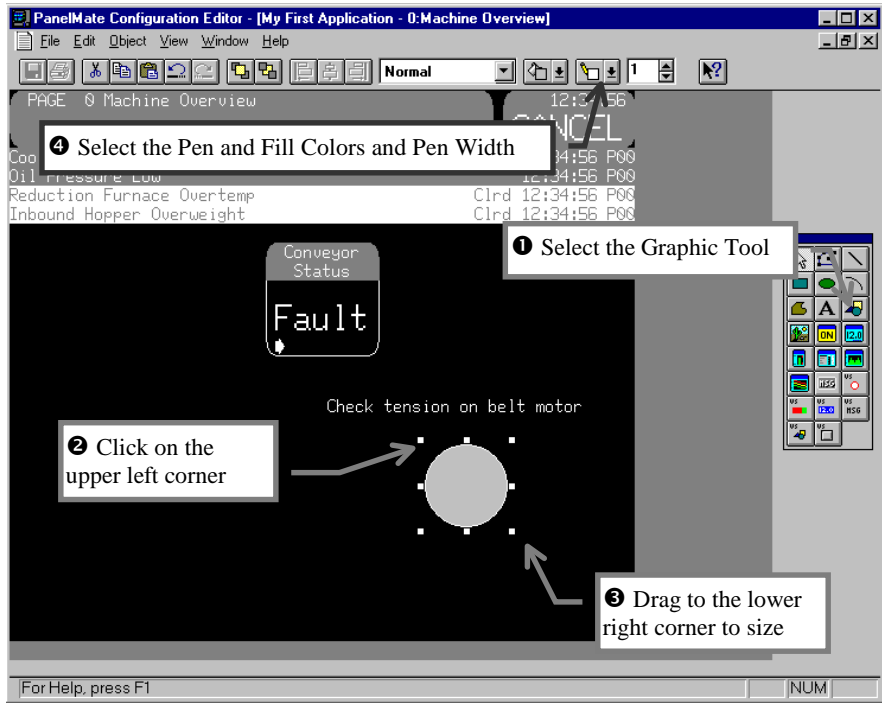

Tips:

- Double-click on a graphic to edit or examine its attributes.
- Select multiple templates and graphics quickly by using a bounding box that encloses all the items. Click on a blank area of the page to define the upper left corner and drag down and release to define the lower right corner. Anything fully enclosed in the imaginary rectangular area is selected.
- Use the arrow keys on the keyboard to move a graphic one pixel at a time or hold down the **Shift** key while using the arrows to move 5 pixels at a time. Holding down the **Ctrl** key in addition to the above will apply the changes to the size rather than the location.
- Holding the **Shift** key while sizing or creating a graphic will constrain it to form a perfect square, circle, or diagonal line.



Create polygons and polylines as follows:

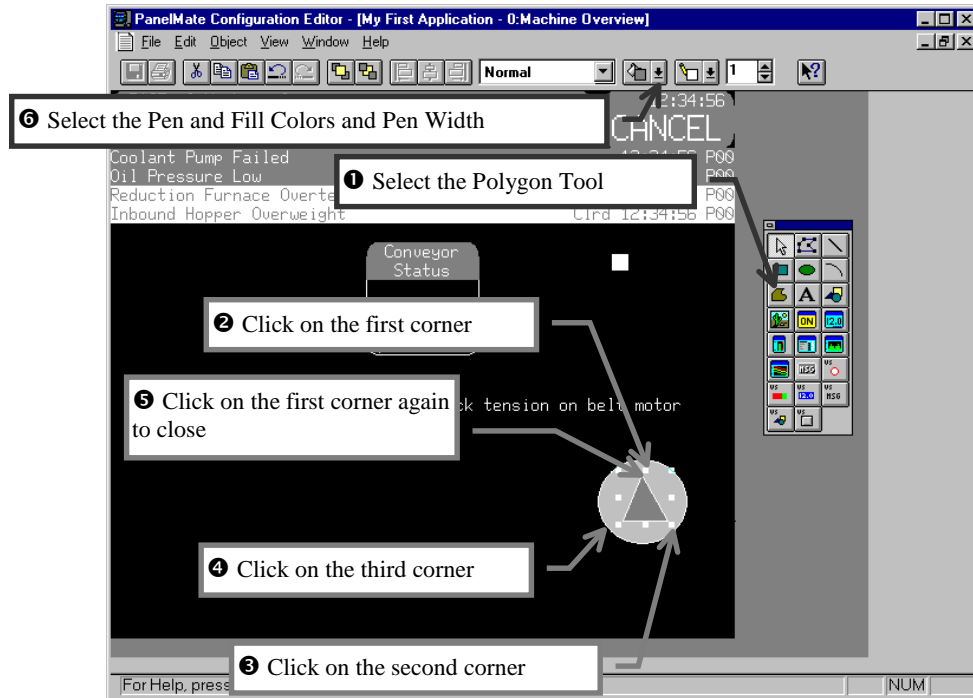

Tips:

- Double-click on the last point to create a polyline instead of a polygon.
- To convert a polyline to a polygon or vice-versa, double click on an existing polyline or polygon and change its style.
- Polygon and polyline vertices can be added, deleted, or moved, and arc starting and ending angles can be changed using the reshape tool.

Note: Small, one-pixel differences may be seen when comparing graphic objects drawn on a page within the PanelMate Configuration Editor and the corresponding PanelMate PC Runtime page.



Creating Symbols

Symbols are created and added to the Symbol Library as follows:

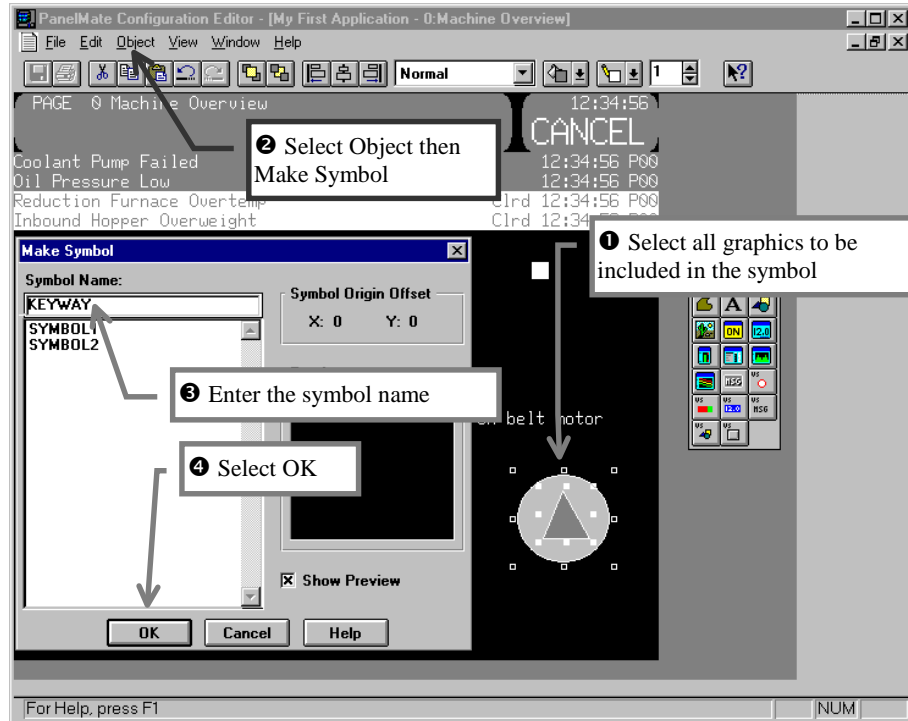

Tips:

- Change all occurrences of a symbol in an application by remaking a symbol with the same name.
- To edit a symbol after it was created or make another symbol that is very close to the same:
 - 1) Place the symbol on the page.
 - 2) Break it using the Break Symbol command in the Object Menu.
 - 3) Change, delete, or add desired graphic elements.
 - 4) Reselect all the elements and make the symbol again.
- Symbols cannot contain other symbols or templates. If a symbol or template is selected, the Make Symbol command in the Objects Menu will be grayed out.



How to Make PowerGraphics Change Dynamically

PowerGraphics can dynamically change by using symbols and defining states, much like the Indicator Templates, using the Variable-Sized Graphic Template as follows:

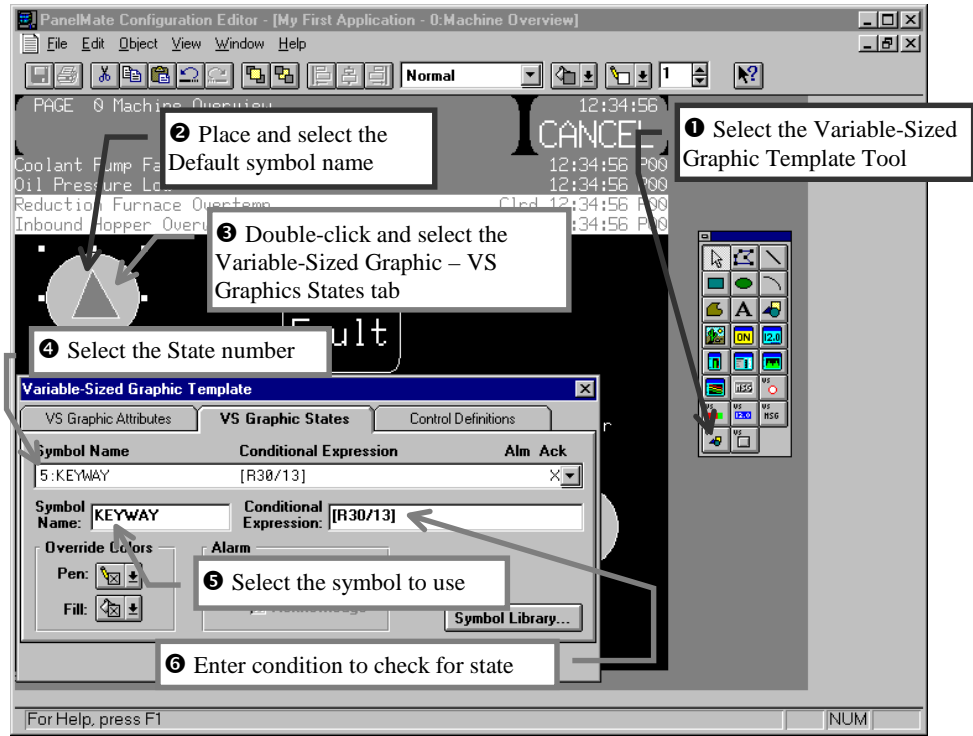

Tips:

- Override Colors change the pen and fill colors used for all elements within the symbol.
- Use the **Symbol Library** button to preview and choose symbols.
- Create simple motion and rotation by creating animation frames as symbols and defining each symbol to a different state.
- Change the symbol's origin offset when creating or modifying the symbol to align it with other symbol origins if necessary.



Saving a Configuration

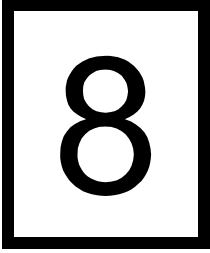

In this chapter, you will learn:

- *How to save a configuration*
- *How to optimize your personal computer for best performance when using the PanelMate Configuration Software*



Saving Changes

If changes were made to the application, the user is prompted to save changes to the database as each window is closed:

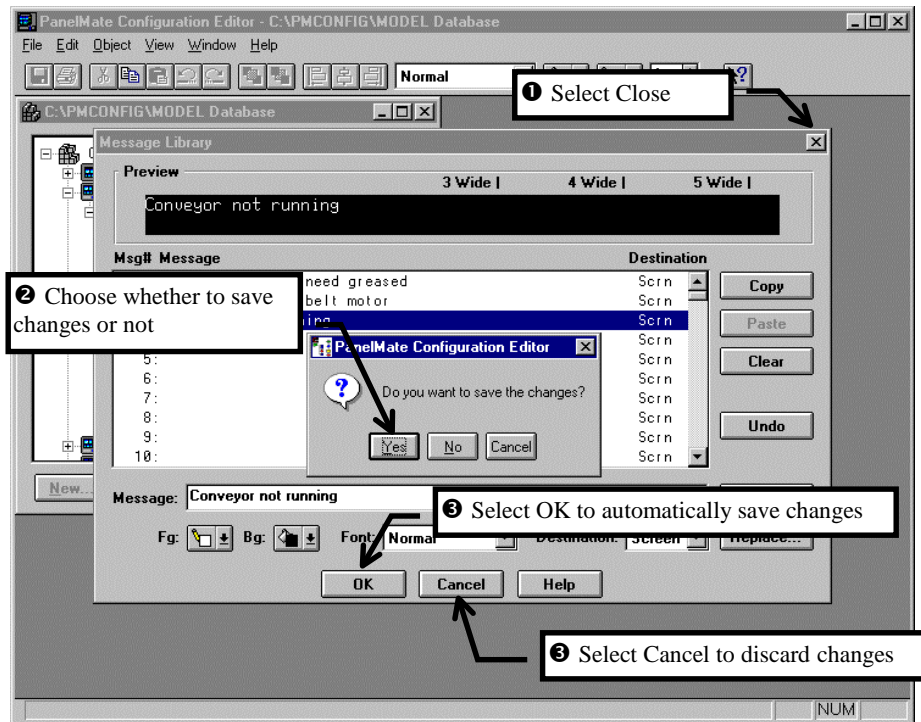

Tips:

- The Configuration Software automatically prompts the user to save each open window with changes if the program is exited.
- After closing all windows, the changes to the database that are common to multiple windows can be saved by selecting the configuration name in the Database Treeview Window and clicking on the **Save** button on the toolbar or by choosing the Save selection from the File Menu.



Optimizing the Performance of your Personal Computer

As with any other Windows-based software, the performance of the PanelMate Configuration Editor will depend on the hardware on which it is run. However, the overall performance of the software, especially when saving configurations and pages, can be dramatically impacted by some key parameters.

Typical display and configuration save times should be in the range of 15 seconds for simple configurations (small number of items/pages) to 60 seconds for large configurations (large number of complex pages). If you are experiencing save times much greater than these and you have a Windows 3.X operating system, the following are recommendations for optimizing your system's performance:

- Enable the SMARTDRV disk caching utility (provided with DOS and Windows). The default setting of 2048 bytes for the cache size is sufficient. This is accomplished by adding the following statement to your **autoexec.bat** file:

```
C:\DOS\SMARTDRV.EXE
```

- Allocate at least 30 disk buffers. The PanelMate Setup Utility automatically modifies your **config.sys** file to this setting. Using more than 30 buffers has little impact on the performance of the software. The following line should appear near the beginning of the file:

```
BUFFERS=30
```

- A 486DX2/66 or higher performance CPU will result in greater performance of the software. Other hardware characteristics such as the amount of extended memory (8 Mbytes or more) will improve performance.
- The size of the system disk, especially the amount of free space available, will affect save time. Disks greater than 200 Mbytes with over 1/2 available free space are optimum. If this is not possible, frequent optimization of your disk through the use of disk compaction utilities, such as Defrag which is a DOS utility, is strongly recommended.



If you have a Windows 95 operating system, the following are recommendations for optimizing your system's performance:

- A 486DX2/66 or higher performance CPU will result in greater performance of the software. Other hardware characteristics such as the amount of extended memory (8 Mbytes or more) will improve performance.
- The size of the system disk, especially the amount of free space available, will affect save time. Disks greater than 200 Mbytes with over 1/2 available free space are optimum. If this is not possible, frequent optimization of your disk through the use of disk compaction utilities, such as the Disk Defragmenter provided by Windows 95, is strongly recommended. (The Disk Defragmenter can be accessed from the Programs/Accessories/System Tools selection which can be selected from the Start button.)

If you have a Windows NT operating system, the following are recommendations for optimizing your system's performance:

- A Pentium 133 or higher performance CPU will result in greater performance of the software. Other hardware characteristics such as the amount of extended memory (32 Mbytes or more) will improve performance.
- The size of the system disk, especially the amount of free space available, will affect save time. Disks greater than 200 Mbytes with over 1/2 available free space are optimum. If this is not possible, frequent optimization of your disk through the use of third-party disk compaction utilities, such as DISKEEPER from Executive Software, is strongly recommended.



Exporting a Configuration

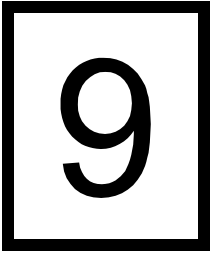

In this chapter, you will learn:

- *How to export a configuration*



Exporting a Configuration

Note: To run a configuration on another PanelMate model, you must first convert the configuration to the appropriate model. Refer to Chapter 13, Converting Configurations, for more information.

Prior to downloading the configuration to the online PanelMate operator station or executing a PanelMate PC configuration in the Runtime Software, the configuration must first be exported from the database to a file as follows:

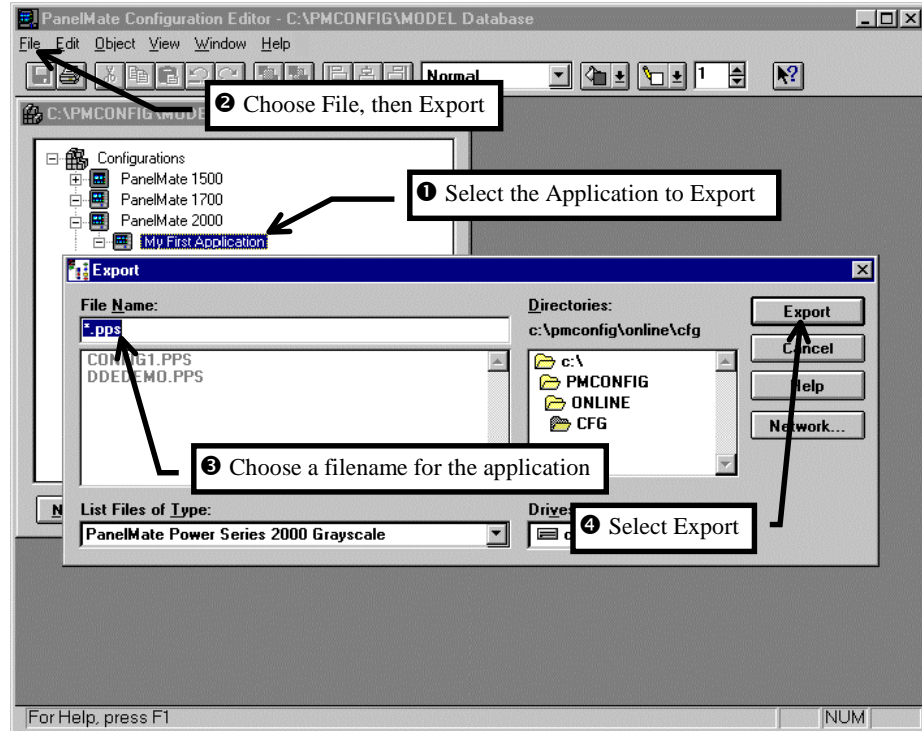

Power Up the PanelMate Operator Station

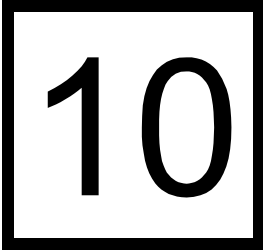

In this chapter, you will learn:

- *How to power up the PanelMate operator station*
- *About the Offline Mode Menu*



Power Up the PanelMate Operator Station

To power up the PanelMate operator station, follow the steps below:

1. Switch the power on. For the PanelMate Power Series 2000 Color or PanelMate Power Series 4000, power up both the monitor and the Electronics Module. Note that this power up sequence must be followed when you are initially powering up the PanelMate operator station or when you are restarting the PanelMate operator station from a power interruption.

If you have a PanelMate Power Series 1700, turn the power on by plugging in the DC power connector. If you are restarting from a power interruption, the power may already be on.

Note: The following steps apply when you are initially powering up the PanelMate operator station or when you are restarting the PanelMate operator station from a power interruption.

2. The PanelMate operator station performs internal diagnostic checks, and displays a listing of the checks as they are executed. If you have a PanelMate Power Series 2000 or a PanelMate Power Series 4000, you may also hear a monitor “crackle”. This is normal. In case of failure, see Chapter 5, Troubleshooting Guide.
3. Then, the PanelMate operator station returns to the state it was in when it was powered off.
 - If the PanelMate operator station was in the Offline Mode, it will return to the Offline Mode and display the Offline Mode Menu.
 - If the PanelMate operator station was in the Run Mode, it will return to the Run Mode and go to the Startup Page as defined by the configuration that is loaded in the unit. It will be necessary to put the PanelMate operator station into the Offline Mode to perform the diagnostic tests.

To go to the Offline Mode from the Run Mode, follow the steps below:

- Select the **Get Page** control button from the default control buttons.
- Select the **More** control button (touchscreen unit) or the **More Buttons** control button (keypad unit).
- Select the Setup Page template.
- Select the Enter Offline Mode template.
- Press the **Execute** control button. After a short delay, the screen will flash and then the Offline Mode Menu will be displayed.



Offline Mode Menu

The Offline Mode Menu displays six selections and is shown below.

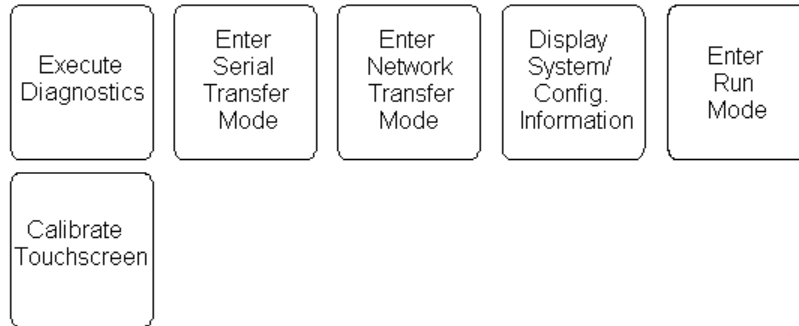

Note: Keypad units do not display the Calibrate Touchscreen selection.

Note: After the diagnostics are completed during power-up, you can force a keypad unit into Offline Mode by pressing the upper two control buttons simultaneously. You can force a touchscreen unit into the Offline Mode by pressing the lower right corner of the touchscreen.

When a PanelMate operator station is forced into Offline Mode, the Offline Mode Menu will be displayed. When the Execute Diagnostics template is selected, the following additional selections will be displayed.

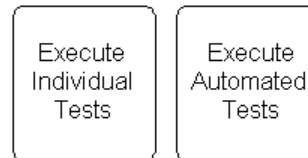

If you select the Execute Individual Tests template, you may execute a specific diagnostic test.

If you select the Execute Automated Tests template on a keypad unit, you may execute each diagnostic test consecutively. If you select the Execute Automated Tests template on a touchscreen unit, you will not be able to execute all of the diagnostic tests.

The selections in the Offline Mode Menu are described in the following sections.



Execute Diagnostics

If you select the Execute Diagnostics template and then press the **Execute** control button, a new page of selections will appear.

You may perform the following tests by selecting the appropriate template and then pressing the **Execute** control button:

- Serial Port Tests*
- Set Date and Time
- Display Test
- Touchscreen Test or Keypad Test
- Tone, Relay, and Battery Test
- System Status

* Note that the Serial Port Tests selection only appears if you force the PanelMate operator station into Offline Mode at startup. For more information on forcing a PanelMate operator station into Offline Mode, refer to the Offline Menu Mode section.

Serial Port Tests

Note: The Serial Port Tests selection only appears if the PanelMate operator station was forced into Offline Mode at startup. For more information on forcing a PanelMate operator station into Offline Mode, refer to the Offline Menu Mode section.

Select the Serial Port Tests template and press the **Execute** control button. A new page will display the tests that can be run. You may test Serial Port 1 or Serial Port 2. You will need to insert a loopback plug to verify functionality of the serial port.

The cabling for the RS232 loopback plug is shown below.

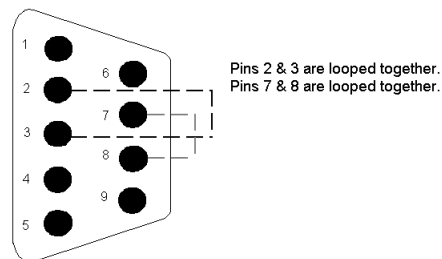

The cabling for the RS422 loopback plug is shown below.

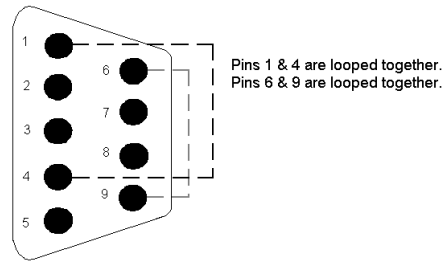

Select a test and press the **Execute** control button. To leave a test, press the **CANCEL** key.

Setting Date and Time

1. Select the Set Date and Time template and press the **Execute** control button. A new page will be displayed.
2. Select Set Date and press the **Execute** control button. The right hand control buttons will change and numeric entry will be enabled. Use the numeric keypads to enter the month, day of the month, and the year using the format MM-DD-YY. Be sure to use the minus key between the numeric values. By pressing the **Enter** control button, the new date will be entered. If the date is already correct, press the **CANCEL** key to exit. Note that if you have a keypad unit, you may press the **Clear** key to clear an entry.
3. Select Set Time and press the **Execute** control button. Use the numeric keys to enter the time as HH-MM-SS with the hours in the 24-hour format. For example, 2:45:11 PM should be entered as 14-45-11. Again, be sure to use the minus key between numeric values. Pressing the **Enter** control button will enter the new time. If the time is already correct, press the **CANCEL** key to exit. Note that if you have a keypad unit, you may press the **Clear** key to clear an entry.
4. Press the **CANCEL** key and then the bottom **Exit** control button to proceed.



Perform Display Tests

Select the Display Test template and press the **Execute** control button. The new page will display the tests that can be run.

If you have a PanelMate grayscale operator station, the tests will be:

Intensity Check	This test will display all the intensities with a brief description of each intensity. Check to ensure that each intensity appears as it is described on your screen.
Solid No Intensity Screen	This test will display a solid no intensity screen. Check to ensure that the screen is displayed without any intensity.
Solid High Intensity Screen	This test will display a solid high intensity screen. Check to ensure that the screen is displayed in high intensity.
Dot Pattern	This test will display a screen with a dot pattern. Check to ensure that the dot pattern on the screen is aligned horizontally and vertically.

If you have a PanelMate color operator station, the tests will be:

Color Check	This test will display all the colors with a brief description of each color. Check to ensure that each color appears as it is described on your screen.
Solid Black Screen	This test will display a solid black screen. Check to ensure that the screen is displayed in black.
Solid White Screen	This test will display a solid white screen. Check to ensure that the screen is displayed in white.
Dot Pattern	This test will display a screen with a dot pattern. Check to ensure that the dot pattern on the screen is aligned horizontally and vertically.

Select a test and press the **Execute** control button. To leave a test, press the **CANCEL** key.

Note: A Grid Check test will also appear if you force a PanelMate operator station into Offline Mode and choose the Execute Automated Tests selection on a keypad unit. This test will display a screen with a grid pattern. Check to ensure that the grid pattern on the screen is aligned horizontally and vertically. For more information on forcing a PanelMate operator station into Offline Mode, refer to the Offline Menu Mode section.

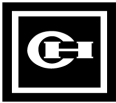

Perform Touchscreen Test

Note: This test only appears if you have touchscreen unit.

This test is used to verify touchscreen operation. Select the Touchscreen Test template and press the **Execute** control button. As the touchscreen is pressed, it is identified on the page display. Test the **CANCEL** key last as it exits the test mode.

Perform Keypad Test

Note: This test only appears if you have a keypad unit.

This test is used to verify keypad operation. Select the Keypad Test template and press the **Execute** control button. As a key is pressed, it is identified on the page display. Test the **CANCEL** key last as it exits the test mode.

Test Tone, Relay, And Battery

This test allows you to verify the audio tone, fault relay, and battery. Select the Tone, Relay, and Battery template and press the **Execute** control button. The new screen will display several selections for testing the tone, fault relay, and real-time clock battery. Note that you must have an alarm horn connected to the PanelMate operator station to test the audio tone.

System Status

Select the System Status template and press the **Execute** control button. The new screen displays the Power Up Diagnostic Results template.

Test Completion

This completes the internal System Health Checks which are available for unit check-out. To turn the power off, disconnect the DC power source.



Enter the Serial Transfer Mode

To download, upload, or read system information over a serial port, the online unit must be in the Serial Transfer Mode. The PanelMate operator station will remain in the ready state until the Configuration Software has initiated the transfer.

Configuration files, drivers, executive firmware, and options can be downloaded to the PanelMate operator station. The configuration file loaded in the PanelMate operator station can be uploaded to the personal computer.

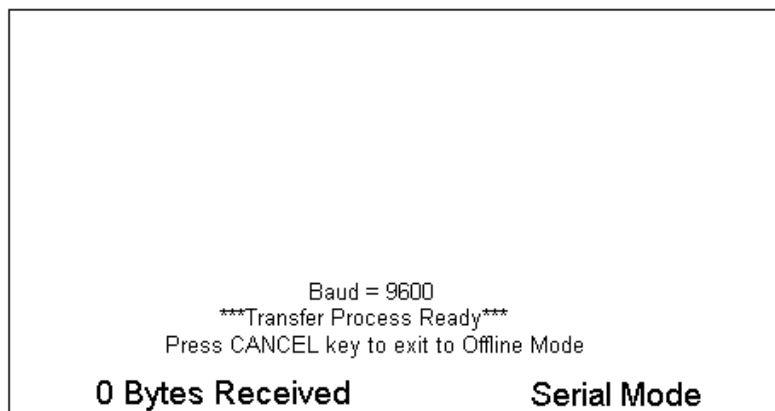

Note that you may refer to the Display System Configuration Information screen before or after a transfer to verify configuration names, executive firmware versions, options, or drivers currently loaded in the system.

You can change the default communication rate in the PanelMate operator station from the Configuration Software. (The default is 9600 baud.) When transferring information, the PanelMate operator station uses port 1.



Enter Network Transfer Mode

Note: The Network Executive Firmware and the network driver must be downloaded using the Serial Transfer Mode before you can transfer over a network.

The PanelMate online unit must have the Remote Transfer option installed and be in the Network Transfer mode to:

- Transfer Information
- Remotely place the PanelMate operator station into Run Mode
- Read system information over a remote network

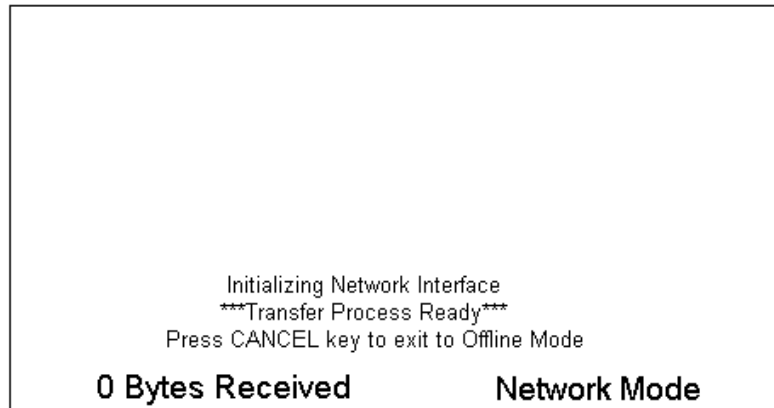

The PanelMate operator station will remain in the ready state until the Configuration Software has initiated the transfer. Configuration files, drivers, executive firmware, and options can be downloaded to the PanelMate operator station. The configuration file loaded in the PanelMate operator station can be uploaded to the personal computer.

The PanelMate operator station can also be remotely placed into Run Mode. For more information on remotely placing the PanelMate operator station in Run Mode, refer to the **PanelMate Transfer - System Info. Tab** topic in the Transfer Utility Online Help.

You may refer to the Display System Configuration Information screen before or after a transfer to verify configuration names, executive firmware versions, options, or drivers currently loaded in the system.



Display System/Config. Information

This selection displays current configuration information from the PanelMate online operator station.

USER CONFIGURATION

Name: FILE1.PPS
Version: X.XX
Date/Time: 6/25/98 11:25
Free Bytes: 80542 Used Bytes: 50530
Options: Modicon Modbus, Advanced Trend Template

EXECUTIVE FIRMWARE

Company/ID: Cutler-Hammer
Product: PanelMate 3000
Version: X.XX
Network: None
Options: Modicon Modbus, Advanced Trend Template

INSTALLED DRIVERS

Generic (Version X.XX)



Enter Run Mode

The Run Mode allows you to display the configuration downloaded to the PanelMate operator station communicating to the PLC of your choice.

If the Remote Transfer option is installed, you can remotely place the PanelMate operator station into Run Mode from your personal computer.

Note: If the value in the Remote Mode Change field in the System Parameters Table is configured as IMMEDIATE, DEFAULT, or ACCEPT, you may also remotely change the PanelMate operator station from Run Mode to the Network Transfer Mode from your personal computer. For more information on remotely placing the PanelMate operator station into the Network Transfer Mode, refer to the **PanelMate Transfer - System Info. Tab** topic in the Transfer Utility Online Help.

To go to the Offline Mode from the Run Mode, follow the steps below:

- Select the **Get Page** control button from the default control buttons.
- Select the **More** control button (touchscreen unit) or the **More Buttons** control button (keypad unit).
- Select the Setup Page template.
- Select the Enter Offline Mode template.
- Press the **Execute** control button and the Offline Mode Menu will be displayed after a pause.



Calibrate Touchscreen

Touchscreen units have a calibration routine that must be performed to determine the boundaries of the video on your touchscreen.

Select the Calibrate Touchscreen template and the following screen will appear:

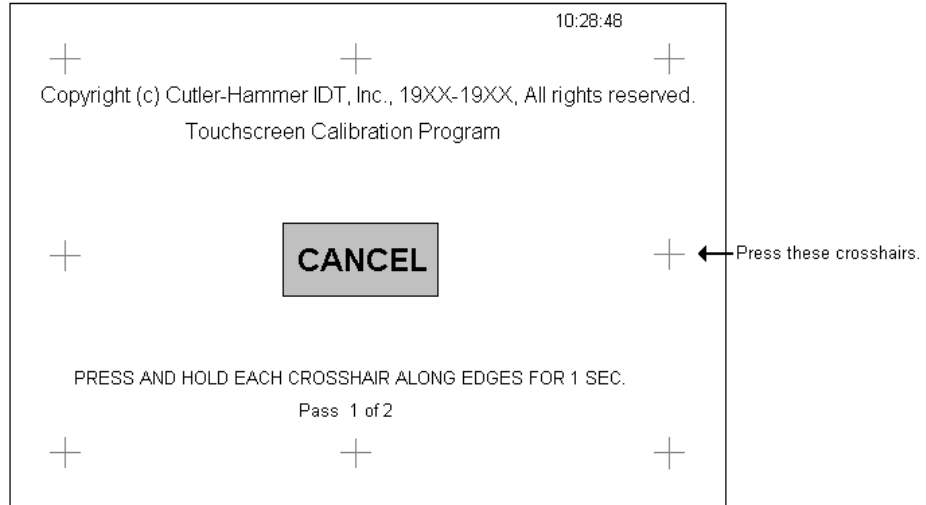

Press the eight small crosshairs around the edges of the screen to calibrate. Press the crosshairs in any order, but all crosshairs must be pressed to complete the calibration.

Each crosshair turns green (or a different shade of gray for grayscale units) when pressed. After the first pass, the crosshairs turn red (or back to the original shade of gray) again to indicate the screen is ready for the second pass. After calibrating, you return to the Offline Mode Menu.

Note: Calibration settings are retained when power is removed from the PanelMate operator station.



Transferring a Configuration

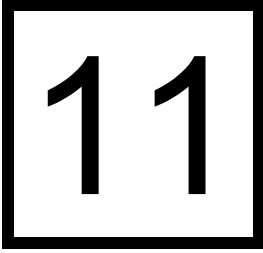

In this chapter, you will learn:

- *How to setup your personal computer and PanelMate operator station*
- *How to perform the file transfer process*



Transfer Overview

Note: If you created a PanelMate PC configuration, you will not transfer the configuration. You may proceed to Chapter 12, Running a Configuration.

This chapter explains how to transfer a configuration from a personal computer to a PanelMate operator station.

The PanelMate operator station requires three separate file types to operate. These files must be the proper version and loaded in the proper sequence for the PanelMate operator station to function properly. The three file types are:

- **Executive Firmware:** This is the master program for each PanelMate operator station.
- **Drivers:** These are the communication protocols. It is recommended that you install the drivers supplied with your version of the Executive Firmware. Current version drivers should not be used with a previous version of Executive Firmware and current Executive Firmware should not be used with previous version drivers.
- **Configurations:** These are the operator screens that you configure. The version of these files can be the same or “older” than the version of the executive firmware in the PanelMate operator station.

Note: To run a configuration on another PanelMate model, you must first convert the configuration to the appropriate model. Refer to Chapter 13, Converting Configurations, for more information.

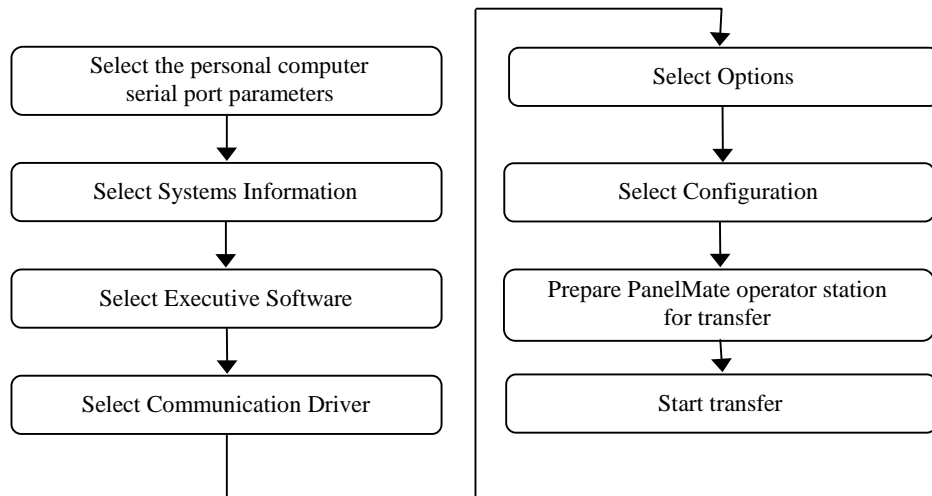

Starting the Transfer Screen

When you have completed a configuration and have saved and exported it, begin the transfer process by choosing the VCP Transfer selection in the File Menu. Note that the configuration software will prompt you to ensure that the configuration has been exported prior to initiating the transfer operation.

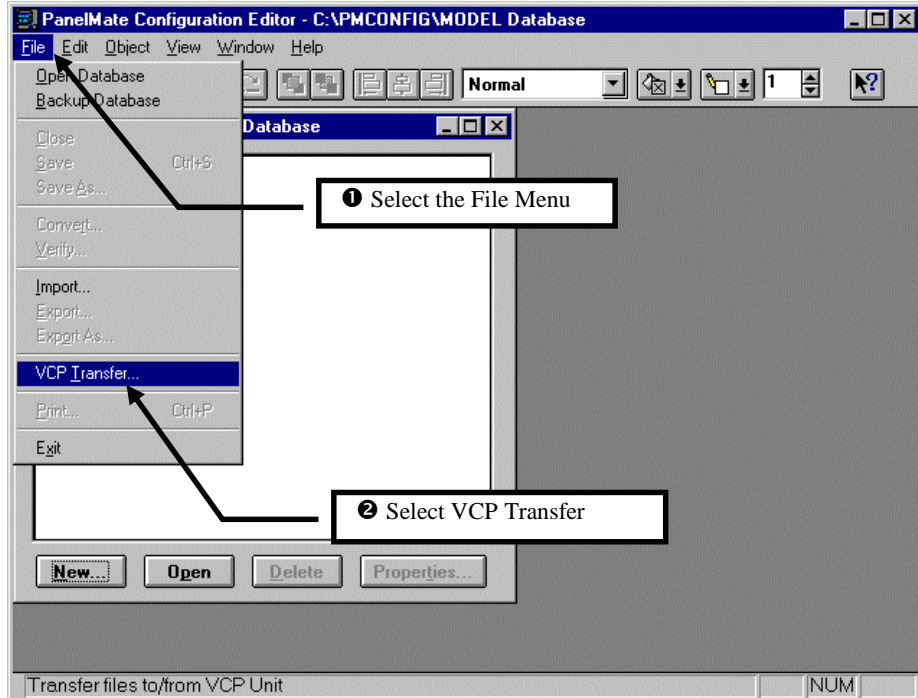

Setting up the Computer Communication Parameters

The computer must be set up properly before the transfer process can begin:

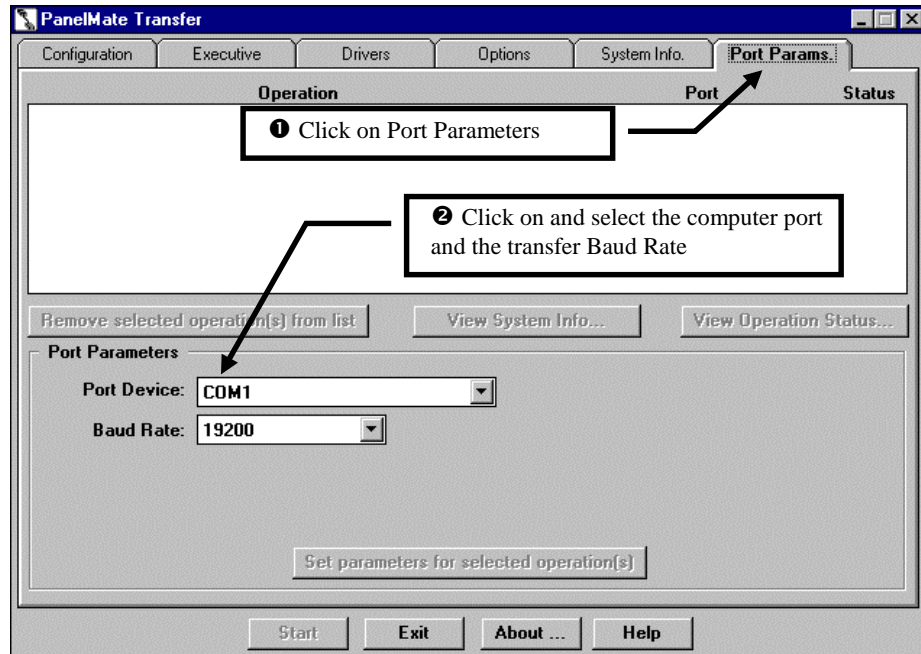

Tips:

- Make sure that the computer communication port that you select in the PanelMate Configuration Software is also set in your computer setup screen as a communication port and not a mouse port.
- Check power saving options in your computer setup screen to ensure they have been deactivated. Most laptops shut down serial ports when they enter power saving modes. If your computer enters a power saving mode and shuts down the serial port, the transfer will fail.

Note: The Port Parameter settings are saved in the `vcpxfcr.ini` file (in the default Windows directory) when the Transfer Editor exits and will not need to be changed every time the Transfer Editor is started.



Determining System Information

The System Information option reads and displays the version of executive firmware, communication driver, and configuration that is currently in the PanelMate operator station. The first transfer is normally a reading of the parameters in the PanelMate operator station so that proper communications can be verified.

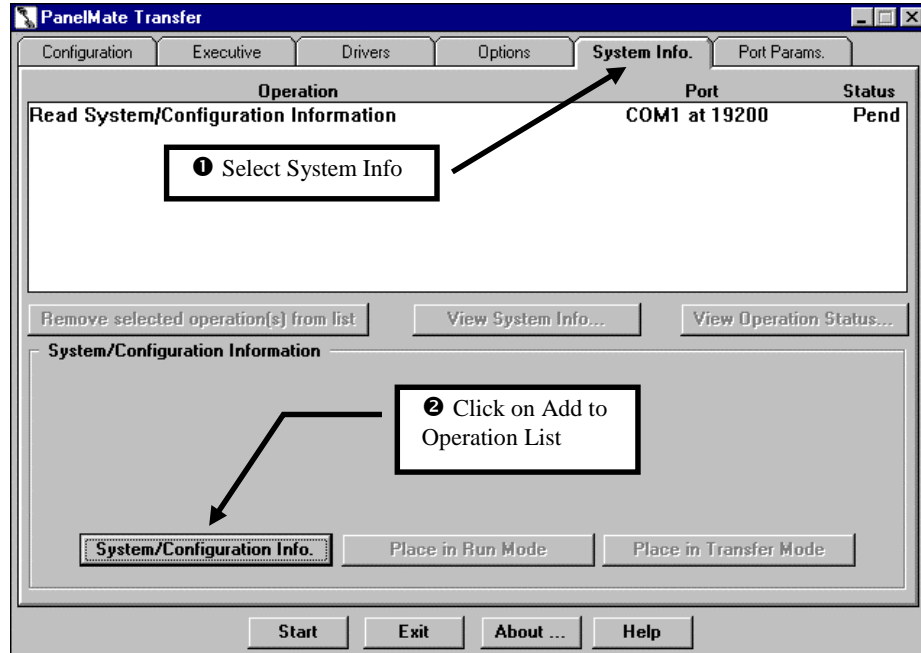

Tips:

- PanelMate operator stations are shipped from the factory loaded with a set of demonstration screens that can be used without having a PLC or controller connected.
- Successfully verifying the information in a PanelMate operator station allows you to confirm that your computer serial port and cable are properly setup.
- Once the system configuration information has successfully been read from the online unit, you must select the Read System/Configuration Information line in the **Operation** list box and then click the **View System Info** button to read the results. The information displayed on this screen is very helpful if you need to contact Cutler-Hammer Customer Support for assistance.



Selecting the Executive Firmware to Transfer

Executive Firmware is normally transferred only when initially setting up an online operator station or when upgrading to a newer version of the PanelMate Executive Firmware. However, this is a good step to ensure that the version installed in your PanelMate operator station matches the version of software you are using.

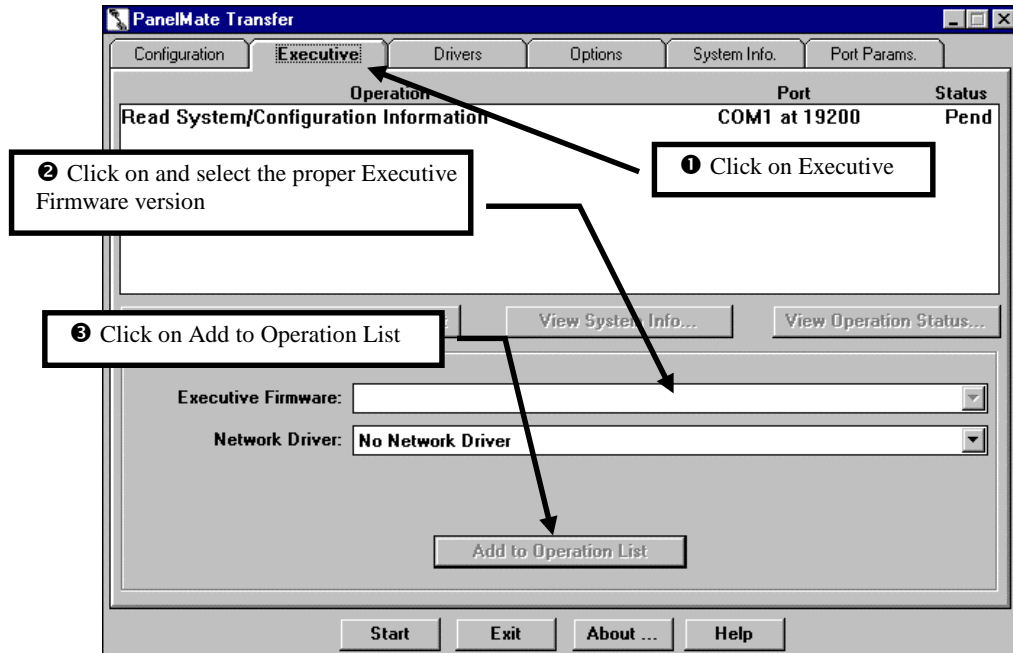

Selecting the Communication Drivers to Transfer

The next step is to transfer the communication driver that you have used in your configuration.

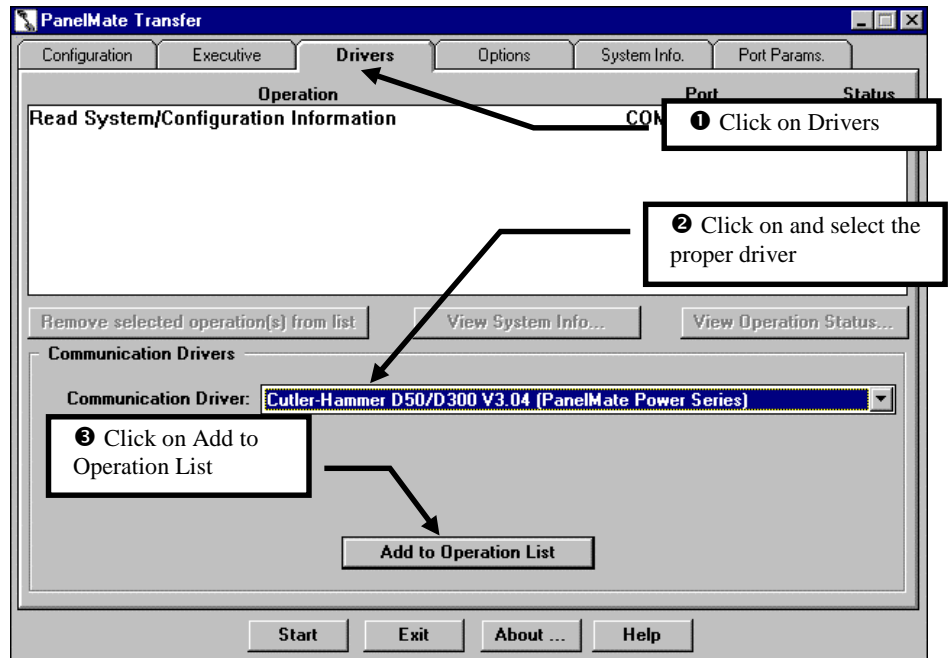

Tips:

- The Option Memory Expansion kit is needed to run more than one communication driver simultaneously in an online operator station.



Selecting Options to Transfer

Note: To run a configuration on another PanelMate Power Series model, you must first convert the configuration to the appropriate model. Refer to Chapter 13, Converting Configurations, for more information.

Any special options that you have used in your configuration must next be transferred into the online operator station. Options are “One Time Use” disks that enable each PanelMate operator station to accept configurations that use a option (e.g., the A-B DH 485 communication driver).

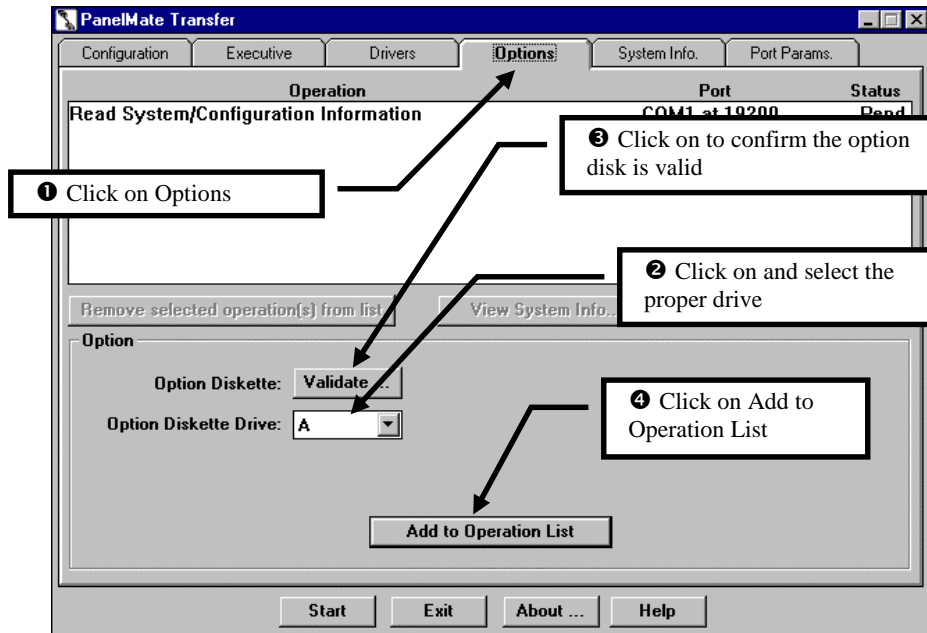

Tips:

- The A-B AcceleratI/On card is not a software option. However, it must be installed in the PanelMate operator station before downloading configuration screens using DH+ or Remote I/O communication drivers.

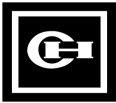

Selecting the Configuration to Transfer

After all other required items have been transferred, the configuration can be transferred to the online operator station. Note that once you select the **Add Configuration File to Operation List** button, the **Download Configuration** dialog box or the **Upload Configuration** dialog box will appear to allow you to select the configuration file to download.

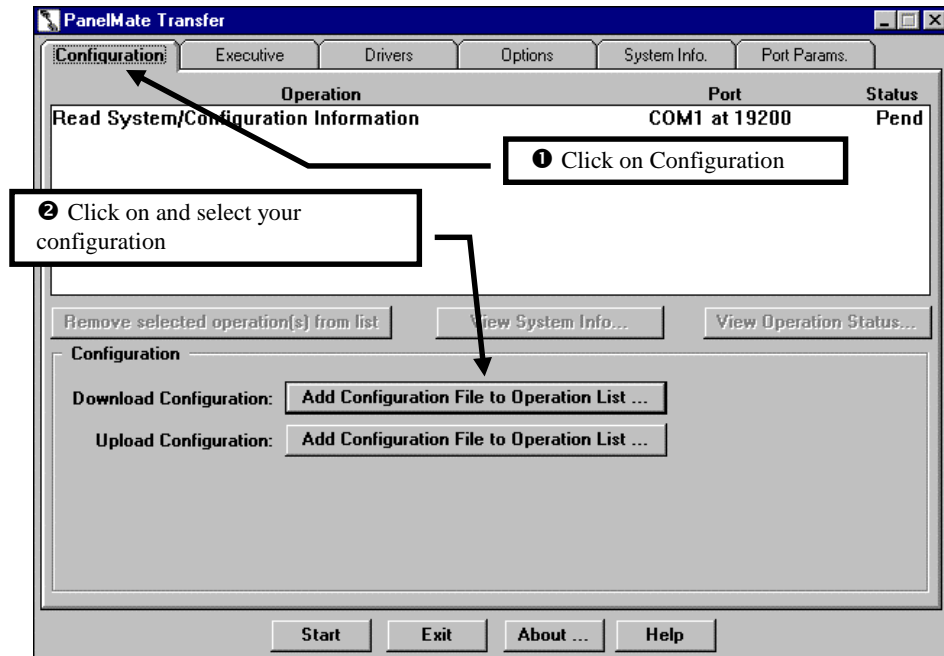

Tips:

- The configuration should have been “verified” before exporting and downloading to check for incorrect PLC/controller references.



Preparing the PanelMate Operator Station for a Transfer

The PanelMate operator station must be changed from the normal on-line run mode into an off-line transfer mode before downloading new files.

The following steps must be performed to place the PanelMate operator station into transfer mode:

- Press the **Cancel Key**.
- Press **Get Page** control button.
- Press the **More Buttons** control button.
- Press **Setup** control button.
- Select the Offline Mode template and press the **Execute** control button.
- Select the Transfer Mode template and press the **Execute** control button.
- Connect the Transfer Cable between the PanelMate (Port1) operator station and the personal computer serial port. We recommend using the Transfer Cable manufactured by Cutler-Hammer; however, the cable diagram is available in the User's Guide.

**Warning**

Do not use a generic RS232/RS422 computer cable unless you have verified it contains the exact pinout required. Extra pins or jumpers may cause problems with the transfer process.



Starting the Transfer Process

Begin the transfer process by clicking on the **Start** button in the **PanelMate Transfer** dialog box. The process will consist of:

- Checking communications and displaying System Parameters of the PanelMate operator station.
- Transfer the Executive Firmware. (Approximately 5-6 minutes to complete)
- Transfer the Communication Driver. (Approximately 2 minutes to complete)
- Transfer the Configuration. (Approximately 1-2 minutes to complete depending upon the configuration file size)



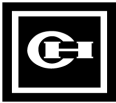

Running a Configuration

12

In this chapter, you will learn:

- *How to run a PanelMate Power Series configuration on a PanelMate operator station*
- *How to run a PanelMate PC configuration on an industrial personal computer*



Running a PanelMate Power Series Configuration

After the download process is complete, the PanelMate operator station needs to be placed in the on-line mode:

- Connect to your PLC and verify the processor is in the Run Mode.
- Press the **Cancel** key on the PanelMate operator station.
- Select the Go On-Line template and press the **Execute** control button.

The PanelMate software performs a hardware diagnostic test and should come on-line in approximately 1 minute.

If the configuration does not come on-line properly or displays a communication error message:

- Verify your configuration to ensure there are no mistakes.
- Confirm that the communication settings in the PanelMate configuration match the settings of the PLC.
- Confirm the PLC cable is correct.
- Consult the error code tables in the Online Operation User's Guide.

If the PanelMate operator station is locked in the on-line startup mode due to an invalid configuration, it can be placed back in the transfer mode by performing one of the following:

- On a keypad unit, cycle power and press the two top control buttons after the diagnostics are completed. Press the buttons until the PanelMate operator station is in the transfer mode. (PanelMate Power Series 4000 and PanelMate Power Series 5000 use buttons 2 and 3.)
- On a touchscreen unit, cycle power and press and hold the lower right corner of the display after the diagnostics are completed.
- Disconnect the electronics module from the front face plate which automatically puts the electronics module in transfer mode on port 1.



Running a PanelMate PC Configuration

After the PanelMate PC configuration is exported:

- Copy the configuration to the PanelMate PC operator station (if different than the personal computer from which the configuration was exported) using either a floppy disk or ethernet network connection
- Connect the industrial personal computer to your PLC or controller.
- Double-click on the Configuration Name (i.e., the .PPS file) to start the Runtime Software.

The PanelMate software performs a hardware diagnostic test and should come on-line in approximately 1 minute.

If the configuration does not come on-line properly or displays a communication error message:

- Verify your configuration to ensure there are no mistakes.
- Confirm that the communication settings in the PanelMate configuration match the settings of the PLC or controller.
- Confirm the PLC cabling is correct, if applicable.
- Consult the error code tables in the Runtime Operation User's Guide.

For more information on executing the Runtime Software, refer to the Runtime Operation User's Guide.





Converting a Configuration

13

In this chapter, you will learn:

- *How to convert a configuration from one PanelMate model to another*
- *Special considerations you must keep in mind*
- *How Copy & Paste and Drag & Drop are similar to the conversion process*



How to Convert A Configuration

Note: To run a configuration on another PanelMate model, you must first convert the configuration to the appropriate model.

This chapter describes the process of converting a PanelMate configuration from one model to another (e.g., Model 2000 to Model 3000). The closely related topics of copy & paste and drag & drop are also discussed.

Converting A Configuration

Conversion is done using the PanelMate Configuration Editor. Refer to the Configuration Editor User's Guide for more information.

To convert a configuration:

1. In the Database Treeview Window, select the configuration you wish to convert.

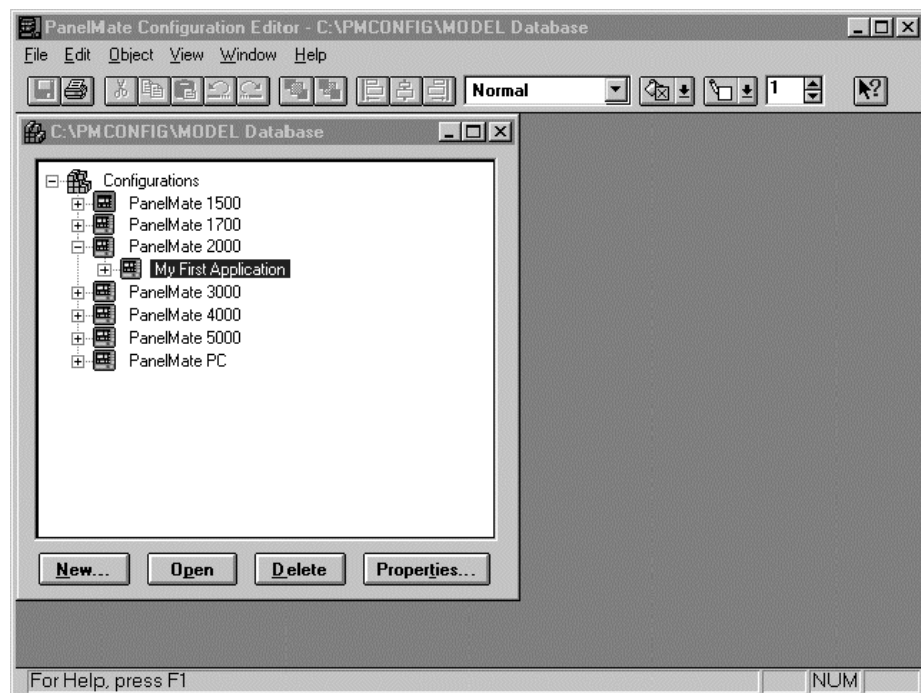

2. Select Convert from the File menu and you will see the **Conversion** dialog box.

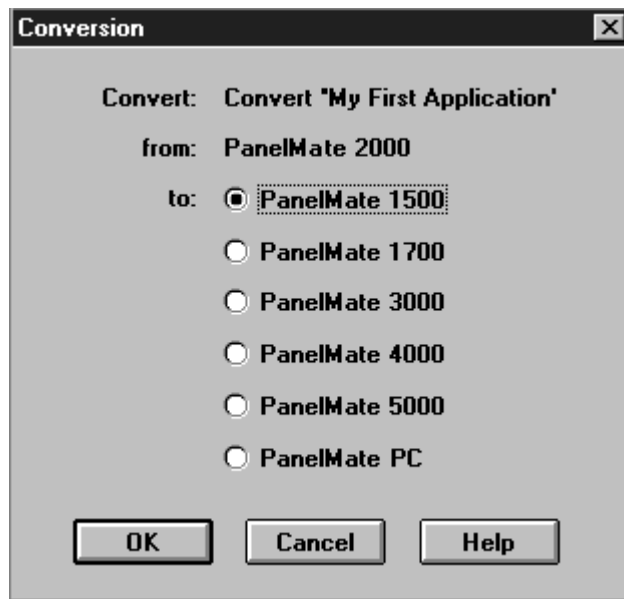

3. Select the model to which you wish to convert.
4. Click the **OK** button.



Conversion Considerations

Converting a configuration between PanelMate Power Series models, and PanelMate PC presents few problems. Most models support the same:

- Number of colors
- Number of pages and messages
- Templates
- Advanced Line Trending

Conversion is simply a process of copying database entries, and maintaining the same configuration as much as possible.

Special considerations when converting:

- PanelMate Power Series 1500 supports fewer pages and messages.
- Converting between a four control button and a five control button PanelMate unit.
- Converting from a PanelMate PC with an NT communications driver, to another PanelMate model. The other PanelMate models may not support the same drivers.

Setting the High Capacity Unit Feature

During the conversion process, the High Capacity Unit feature is automatically set as needed. Note that the PanelMate 1500 High Capacity supports fewer pages and messages than the other PanelMate models. See the **Product Features** topic in the Configuration Editor User's Guide for more information.



Setting the Color Display Feature

When converting to PanelMate Power Series 1500, PanelMate Power Series 1700, PanelMate Power Series 2000, or PanelMate Power Series 3000, the Color Display feature is not automatically set. The new configuration appears in grayscale.

If the source configuration was color, use the **Configuration Properties** dialog box to select the Color Display feature. See the **Configuration Properties** topic in the Configuration Editor User's Guide for more information.

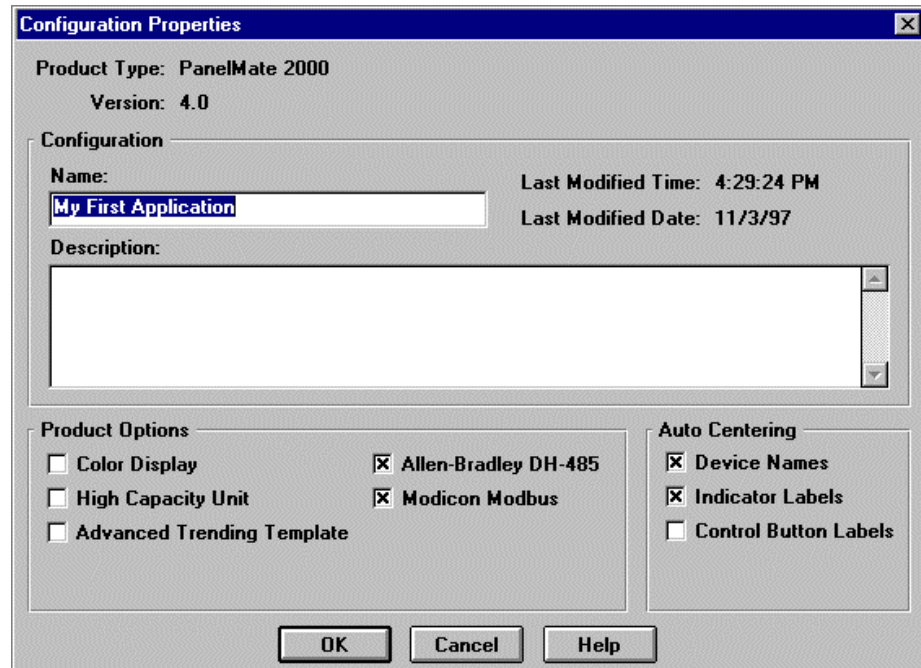

The screenshot shows the "Configuration Properties" dialog box for a PanelMate 2000 configuration. The dialog has a title bar with a close button. The main content area is divided into several sections:

- Product Information:** "Product Type: PanelMate 2000" and "Version: 4.0".
- Configuration Section:**
 - Name:** A text box containing "My First Application".
 - Last Modified Time:** "4:29:24 PM".
 - Last Modified Date:** "11/3/97".
 - Description:** A large empty text area with a vertical scrollbar.
- Product Options:** A group box containing three checkboxes:
 - Color Display
 - High Capacity Unit
 - Advanced Trending Template
- Auto Centering:** A group box containing three checkboxes:
 - Allen-Bradley DH-485
 - Modicon Modbus
 - Device Names
 - Indicator Labels
 - Control Button Labels

At the bottom of the dialog are three buttons: "OK", "Cancel", and "Help".



Converting to PanelMate Power Series 1500

Even with the Capacity Expansion feature installed, the PanelMate Power Series 1500 supports fewer pages and messages than the other PanelMate models. See the **Product Features** topic in the Configuration Editor User's Guide for more information.

Converting to PanelMate Power Series 4000, PanelMate Power Series 5000, and PanelMate PC

PanelMate Power Series 4000, PanelMate Power Series 5000, and PanelMate PC are color only. Therefore, when you convert another model to a PanelMate Power Series 4000, PanelMate Power Series 5000, and PanelMate PC, the Color Display feature is always set for the new configuration.

- If the source configuration was color, the new configuration will be color.
- If the source configuration was grayscale, the new configuration may be color if the proper grayscale values were used. See the **Converting Grayscale To Color** topic later in this chapter for more information.

Converting from PanelMate Power Series 4000, PanelMate Power Series 5000, and PanelMate PC

PanelMate Power Series 4000, PanelMate Power Series 5000, and PanelMate PC provide five control buttons while all other models provide four. The new configuration will be created minus the fifth (bottom) control button. This can cause problems if the old configuration depended upon the fifth control button.



Converting Grayscale to Color

PanelMate Power Series models that are available with color or grayscale displays have two, 256 selection palettes.

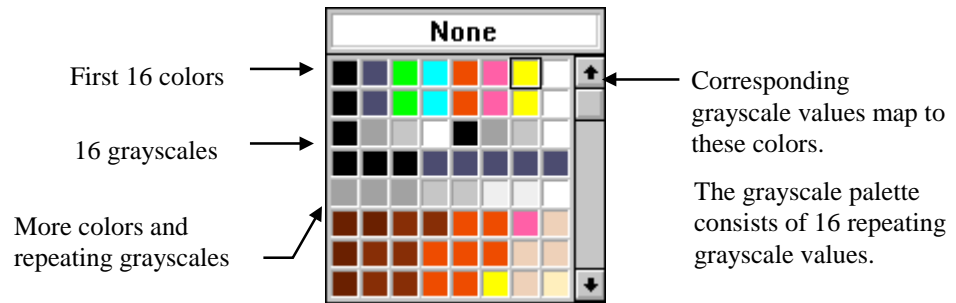

The first 16 colors in the color palette correspond to the first 16 grayscale values in the grayscale palette. If you create a grayscale configuration using ...

- The first 16 grayscale values, these values change to colors when you convert the configuration to color
- Other than the first 16 grayscale values, these remain grayscale in the new color configuration.

Copy & Paste, Drag & Drop

You can copy & paste objects from one configuration to another using the Windows clipboard. You can also use the Windows drag drop method. When the source and destination configurations are for different PanelMate models, pasted or dropped objects are automatically converted to the new configuration.

This is similar to the conversion process discussed above, the only difference being that the object assumes the color palette of the destination configuration.



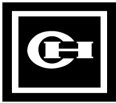

Troubleshooting Guide

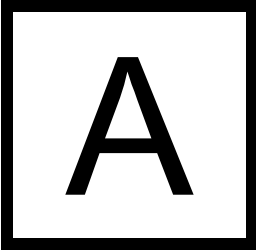

In this chapter, you will learn:

- *Problems with the display*
- *Problems with the touchscreen*
- *Problems with the keypad*
- *Problems with the control buttons*
- *Problems with audio output*
- *Problems with fault relay*
- *Problems with a printer*
- *Problems when transferring memory*
- *Problems with the real-time clock*
- *Communication problems using the Generic Protocol*



Problems with the Display

Screen is dull, no picture on the screen, or no characters on the display

Make sure your power source is actually supplying power to the PanelMate operator station.

Single message on a black screen that says "press any membrane key to resume display"

This is normal operating procedure when the System Parameters Editor has been set for Automatic Screen Blanking. To disable this feature, set Screen Blanking Inactivity Period to OFF. Refer to the **System Parameters** topic in the Configuration Software online help for more information.

Watchdog timeout message on a screen that says "Watchdog Timeout. Press Cancel key to continue"

A watchdog timeout error may indicate a problem with PanelMate hardware or it may be related to DC power. If problems persist, call your local distributor. Please have the unit's serial number ready for the distributor who serves your call.

Problems with the Touchscreen

Touchscreen is not performing reliably

Run the Touchscreen Test as described in Chapter 10.

Re-calibrate the touchscreen. (Refer to the **Calibrate Touchscreen** topic in Chapter 10.)

Problems with the Keypad

One or several membrane keys do not work

Use the Keyboard Test to ensure the keys are sending a signal to the PanelMate operator station. (Refer to the **Execute Diagnostics** topic in Chapter 10).



Problems with the Control Buttons

One or several buttons do not work

Use the Keyboard Test to ensure the keys are sending a signal to the PanelMate operator station. (Refer to the **Execute Diagnostics** topic in Chapter 10).

Problems with the Serial Port

Cannot establish communication using the serial port

Check cable integrity to ensure there are no missing pins or broken wires.

Ensure the communication parameters (baud rate, stop bits, parity, etc.) are the same in both the PanelMate operator station and the PLC.

Check the serial port termination.



Problems with Audio Output

No sound is produced

Check the System Parameters Table to make sure you have the audio output set for either LOW, MED, or HIGH volume. Refer to the **Execute Diagnostics** topic in Chapter 10 for more information.

Check the connection of the speaker to the PanelMate operator station.

Check the integrity of the speaker cable.

If you have purchased your own speaker, make sure it is an 8-ohm speaker. Go offline and run the audio tests.

Sound is only produced for operator input or alarms

Check the System Parameters Table to make sure you have the audio output set correctly. Refer to the **System Parameters** topic in the Configuration Software online help for more information.

Problems with the Fault Relay

Fault relay is not energized at start of Run Mode operation

View the PanelMate operator station screen to check for system or communications errors that may be reported. Refer to the **Error Codes** topic in the Configuration Software online help for more information.

Use the fault relay health check to make sure the relay is working properly.

If you are using Generic Protocol, make sure your host is not polling the PanelMate operator station before it has a chance to energize the relay.

Fault relay de-energizes when an alarm occurs

This is a normal operation if you have used the System Parameters Table to set this feature. Use the System Parameters Table to disable this feature. Refer to the **System Parameters** topic in the Configuration Software online help for more information.



Problems with a Printer

Printer will not work

Check to make sure the printer cable is connected to Port 1.

Check the Port Parameter Table. Make sure Port 1 is selected for PRINTER use.

Verify that all communications parameters match between the PanelMate operator station and your printer.

Check to make sure the printer is ready; if the printer is out of paper or off-line, it will not work.

Check the integrity of the cable and connections. Verify that the cable is wired properly.

Check the integrity of the PanelMate communications port by restarting the system (power off, then re-power), and noting the report of the power-up diagnostics.

Verify that the printer is set for serial communications.



Problems when Transferring Memory

Cannot make a personal computer transfer

Make sure that the cable connecting the personal computer serial port to the PanelMate operator station serial port is the one supplied by Cutler-Hammer.

Check the integrity of the PanelMate operator station communications port. Do this by restarting the system (power off, then re-power) and noting the report of the power-up diagnostics. Make sure you are connected to the PC serial port selected in the **PanelMate Transfer - Port Params. Tab** dialog box.

Cannot download from the personal computer

The file you are attempting to load from the personal computer may be corrupted. Re-save the configuration to the personal computer, then try to transfer the configuration again.

Problems with the Real-Time Clock

The time is inaccurate following a power disruption

This is a symptom of a dead or low battery. Check the integrity of the battery. Do this by restarting the system (power off, then re-power) and noting the report of the power-up diagnostics.

Communications Problems using the Generic Protocol

PanelMate operator station does not respond at all

Verify that the host is using the frame format exactly as specified in the Generic Protocol Driver Manual.

Make sure that the cable connecting the host to the PanelMate operator station is properly wired.

Verify that you have properly set the communications parameters on the host to match the parameters of the PanelMate serial port.

Check the integrity of the PanelMate communications port by restarting the system (power off, then re-power) and noting the report of the power-up diagnostics.



Specific Error Messages

Error encountered during initialization of data structures

Return to the Configuration Mode and check the PLC Name and Port Table. Especially verify all Network ID numbers and the default PLC. A default PLC must be named, even if you are using one PLC.

Error in memory checksum calculation

This error message indicates that all or part of the system configuration memory is corrupted. Most commonly, this error is displayed after improperly exiting a system table. To correct this error, recalculate the checksum by entering and exiting the table as normal.

Errors identified by audible tones when message display is not possible

For certain fatal startup errors which do not permit fault messages to be displayed on the screen, the PanelMate operator station will generate special alarm tones to an alarm horn connected to the Audio port. If the real-time clock is inaccessible, a 1000 Hz tone will be generated in the following repeating pattern: .5 second tone, .5 second pause, .5 second tone, 3 second pause.

If the video subsystem has fatal errors, an alarm tone pattern is generated to indicate the actual failures. A 1000 Hz tone with .25 seconds duration indicates a test has passed. A 800 Hz tone with .5 second duration indicates a test has failed. A 3 second pause occurs at the end of the tone sequence. The tests are performed in the following order:

- Serial Port 2
- Serial Port 1
- Real-Time Clock (Timing)
- Real-Time Clock Battery
- DRAM
- Watchdog
- Character Cell SRAM
- Frame Buffer SRAM



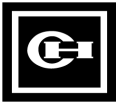

Reader Comment Card

Cutler-Hammer strives to provide quality user guides and product manuals. Please take a moment to fill out this comment card.

Title: Getting Started User's Guide 01-00397-00

	Excellent	Good	Fair	Poor
Is the document easy to follow?	<input type="checkbox"/>	<input type="checkbox"/>	<input type="checkbox"/>	<input type="checkbox"/>
Does the product work as described in this document?	<input type="checkbox"/>	<input type="checkbox"/>	<input type="checkbox"/>	<input type="checkbox"/>
Are the instructions easy to follow?	<input type="checkbox"/>	<input type="checkbox"/>	<input type="checkbox"/>	<input type="checkbox"/>
Are the examples helpful/useful?	<input type="checkbox"/>	<input type="checkbox"/>	<input type="checkbox"/>	<input type="checkbox"/>
Are there enough examples?	<input type="checkbox"/>	<input type="checkbox"/>	<input type="checkbox"/>	<input type="checkbox"/>
Is the document organized logically?	<input type="checkbox"/>	<input type="checkbox"/>	<input type="checkbox"/>	<input type="checkbox"/>
Is it easy to find what you are looking for?	<input type="checkbox"/>	<input type="checkbox"/>	<input type="checkbox"/>	<input type="checkbox"/>
Are the illustrations clear and useful?	<input type="checkbox"/>	<input type="checkbox"/>	<input type="checkbox"/>	<input type="checkbox"/>

How would you improve this document?

Please list any errors found in this document:

Other comments:

Your name and address: (optional)

Thank you for your comments. Please fax this page to:

Cutler-Hammer Technical Publications Dept.

FAX : 614-882-0289



Artisan Technology Group is an independent supplier of quality pre-owned equipment

Gold-standard solutions

Extend the life of your critical industrial, commercial, and military systems with our superior service and support.

We buy equipment

Planning to upgrade your current equipment? Have surplus equipment taking up shelf space? We'll give it a new home.

Learn more!

Visit us at artisanng.com for more info on price quotes, drivers, technical specifications, manuals, and documentation.

Artisan Scientific Corporation dba Artisan Technology Group is not an affiliate, representative, or authorized distributor for any manufacturer listed herein.

We're here to make your life easier. How can we help you today?

(217) 352-9330 | sales@artisanng.com | artisanng.com

