



## ***VF 610 PLUS advanced edition vacuum filler***

***THE EDITION FOR MODERN SMALL-SCALE PRODUCERS.***



For sausage and meat products, delicatessen, vegetarian and vegan products, dairy products, confectionery, fish products, pet food and other products.

**The VF 610 plus advanced edition is optimally designed for universal food processing at small-scale producers or start-ups. Whether sausage and meat products or products for catering, lunch menu, barbecue and the like: burgers, rissoles, dumplings and balls, cevapcici, delicatessen salads, dips and sauces, spreads, ready meals and much more can be produced in first-class quality with the VF 610 plus advanced edition and the flexible Handtmann auxiliary devices.**

## **YOUR ADVANTAGES**

- New, modern look and with innovations of the new VF 800 vacuum filler generation
- Revised control system with colour display and 300 product memory locations as well as auxiliary socket for easy synchronisation and communication with auxiliary devices
- Maximum suitability for everyday use thanks to simple and intuitive operation as well as fast product changes for small batches with minimum amounts of residual product
- Powerful processing and precise portioning of soft, pasty, chunky, firm or cold products
- Wide variety of products due to high flexibility and versatile auxiliary devices
- Reliable production with high, effective portioning and linking capacity
- Excellent weight accuracy and first-class product quality thanks to gentle and adjustable Handtmann vane cell feed system
- Low operating and maintenance costs thanks to the use of industrial-standard technology
- CE-compliant safety and hygiene concept in accordance with the most recent EU standards

## OPTIONAL AUXILIARY DEVICES FOR PORTIONING, LINKING, DOSING, FORMING AND CUTTING

- AG 410 linking gearbox
- HV 412, HV 414, HV 416 automatic holding devices
- DA 78-6 casing spooling device
- MSE 441 forming and cutting unit
- DV 85-1 dosing valve
- DV 85-3 dosing valve
- Can filling arm
- TW 449-04/449-05 parts trolleys and many more.



## PERFORMANCE PARAMETERS

Filling capacity	up to 3,000 kg/h
Portioning and linking capacity	up to 500 portions/ minute (servo linking)
Portioning range	from 5 to 200,000 g
Hopper volume	40/100 litres (dividable)
Filling pressure	up to 35 or 50 bar in portioning and linking operation
Drive	Powerful, high-precision and energy-efficient servo main drive



Control with colour display



Vane cell feed system



VF 610 plus advanced edition controls for ergonomic working and optimum level of hygiene

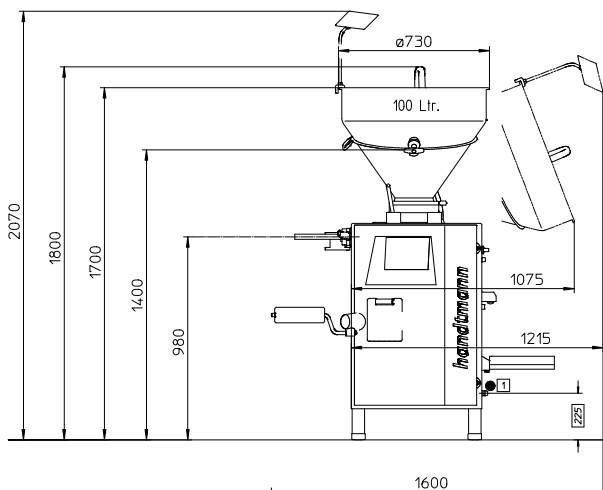

Virtual patent marking: [www.handtmann.com/patents-mf](http://www.handtmann.com/patents-mf)